

# PS40 F

## Programming and adapting wash programs

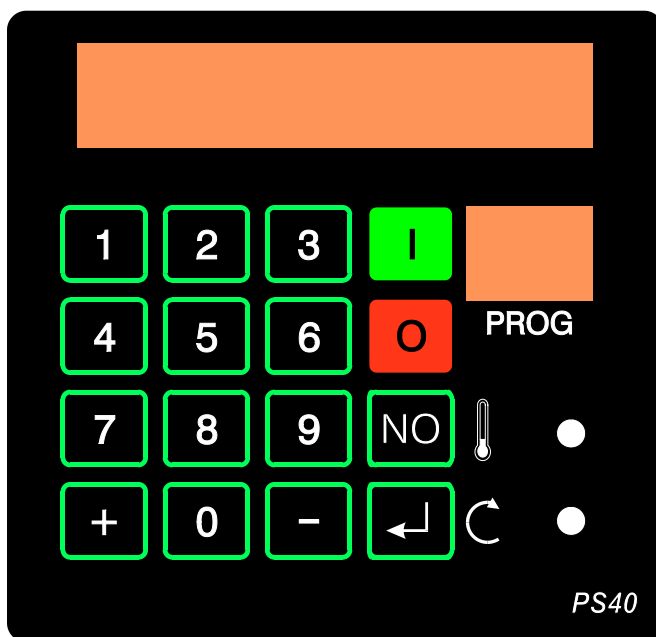

Alliance International bvba - Nieuwstraat 146 - B-8560 Wevelgem (Belgium)

Tel. +32 56 41 20 54 - Fax +32 56 41 86 74 - [info@alliances.eu](mailto:info@alliances.eu) - [www.alliances.eu](http://www.alliances.eu)



# Contents

---

<b>1 Introduction</b> .....	5
Programmer PS40.....	5
Circuit diagrams.....	5
<b>2 Division</b> .....	7
<b>3 Pre-programming mode</b> .....	9
Pre-programming.....	9
<b>4 Programming mode</b> .....	18
Programming .....	18
Inserting and deleting a program part.....	34
<b>5 Copying mode</b> .....	36
Copying mode.....	36
<b>6 Operating mode</b> .....	38
Selecting a program.....	38
Starting a program.....	38
Course of the program.....	38
Programmed start.....	39
Changing the program.....	39
Changing the level, the washing time and the temperature once.....	39
Controlling the temperature of the bath and the number of revolutions.....	39
Controlling the program during functioning.....	40
Running through the program quickly.....	40
Programmed stop .....	40
Soaking.....	40
Time stop.....	41
Interrupting and stopping the program.....	41
Filling up with water .....	41
Discharging the water.....	41
Heating the bath .....	41
Adding soap.....	42
Error messages .....	42
<b>7 Test mode</b> .....	45
<b>8 Liquid soap connection</b> .....	46
Standard programs.....	47

Version 3.22 **B**

Code: 249/00247/00  
03/03/2009

# Index

SC (( 21  
SF (( 21

## A

A (( 21  
A2 42  
A4 42  
A5 42  
A7 42  
A8 42  
A9 42  
AB 42  
AD 42  
AH 42  
ACCL 17, 40  
ADD 17, 27  
ALARM ((( 17 27 33

## B

BU% 17

## C

CD' & (( 27  
CDN (( 27  
CDN& (( 27  
CDU (( 27  
CLOSE 41  
COLD 39  
COOL 27  
COPY PRG 7, 37

## D

D1 13  
D2 13  
DATA(((( 33  
DATA(((( 7  
DEFAULT 17  
DEST. )) 37  
DI 29, 31  
DI ST 31  
DI ST 31  
DOOR. OPEN 38  
DRAIN 31  
DT ((( 31

## E

EMER 17  
END 33  
ENTER 40

## F

F5 42  
F6 42  
FC 9  
FREE%((( 33

## G

GENTLE 15, 23  
GOOD(((( 7

## H

HEAT 15, 21  
HEAT- MOD 15, 21  
HEAT- SYS 15, 21  
HECO 15, 23, 39  
HOURS 7  
HF 9  
HYST 17

## I

I 1 11, 23  
I 2 11, 13, 23  
I 3 11  
I 4 11  
I 5 11  
I 6 11  
II 11  
IR1 13

## J

JOLT 31

## L

L (( 39  
L XX 39  
LE (( 25  
LECO 9, 25, 39  
LOG 7  
LS (( 25

## M

MOD 15, 21

## N

NO ADD 27

## O

OPEN DOOR 41

## P

P(( END 38  
PRE 7, 9  
PROG 19  
PROG (( 7, 38  
PROG COPY 7  
PROGEDI T 7  
PROGLI ST 7  
PROG PC 7  
PROGR 7  
PROGRAM 7  
PROM(((( 7

## R

RAM FULL 19, 35, 37  
RD1 13  
RD2 13

## S

S (( 21  
SE- I 9, 7, 25, 29, 44  
SOAK 27, 40  
SOAK ((( 27  
SOAKTI ME 40  
SOAP (( 15, 25  
SOURCE. (( 37  
SP (( 21  
SP ((( 29  
SPI - ( 29  
SPI N 29  
SPI T 29  
START 7, 43  
STOP 27, 40  
STOP ((( 27  
STOPTI ME 40

## T

T \$C 15  
T (( 39  
T \$F 15  
T= ((( 31  
T=\$(( \$C 39  
T1 25  
TD ((( 29  
TEST 7, 43, 45  
TI HOLD 17  
TU ((( 33

## W

WASH 31

## X

(( DETI 29  
(( CYTI 19  
(( DEL 35  
(( I D (( 19  
(( ROTE 19  
(( SE- I 23  
(( SE- L 25  
(( TEMP 21, 25  
((- - )) 37  
(( TI STOP 41

## PS40F Programmer

On machines with an electronic freely programmable programmer PS40F, it is possible to program 40 programs of your choice (0 to 39). **10 standard programs** (40 to 49) are also at your disposal. Operating the machine, as well as entering the data in order to obtain a washing program, can be done by means of the keyboard on the control panel or by optical downloading from the PC. You can also download existing programs from the machine into the PC in order to modify or transfer them to another machine.

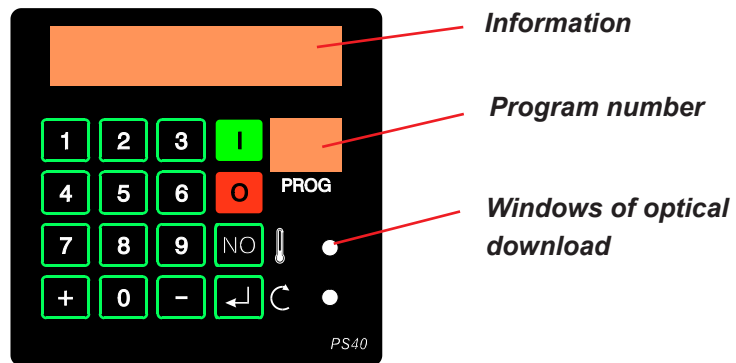

## Circuit diagrams



In this manual you will find several circuit diagrams. Below is an explanation of the symbols used.

Represents a text that appears on the display.

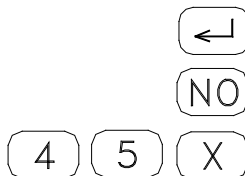

These symbols with rounded edges represent the pressing of certain keys, to be found on the keyboard.

Ex. Digits, Start, Stop, etc. (X stands for a digit of your choice).

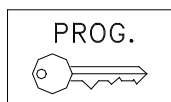

The symbols in rectangles represent mechanical actions to be executed.

Ex. Switch key switch in front

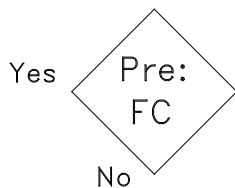

A symbol in a window represents a needed software implementation.

Ex. If a frequency controlled motor was chosen in the preprogram, a machine with coin switch was selected, or not, etc.



When a machine is placed under pressure, a so-called “Eprom test” is executed. “PROM( ( ( ( ” and “GOOD( ( ( ( ” appear temporarily on the display (XXXX stands for the serial number of the Eprom). Then “DATA( ( ( ( ” appears temporarily. This is the “checksum” of all data. This value modifies each time, that there are changes in the programming.

“START” appears afterwards.

By entering a program number, you can select a washing program (“PROG ( ( ” is shown) or you can proceed to other modes by pushing the “-” or “+” button.

**Remark :**

When a machine is put under pressure *for the first time*, or when an error occurs in the Ram memory (memory of the washing program), “A3” will appear. Press “ENTER”.

When the switch is put in “Run” level, you can only select out of “PROGLI ST” and “HOURS”.

## PROGEDI T (*programming mode*) (E455)

You can insert step by step the necessary data to obtain a full washing cycle of your choice.

To program a washing program : see further in chapter 4.

## PROG PC (*download mode*) (E938)

Programs composed in a PC can be downloaded in the machine, or programs from the machine can be downloaded in the PC.

## PROGCOPY(*copy mode*) (E328)

Existing programs can be programmed to another program number.

This can save you a lot of programming work for similar programs.

To copy a program : see further in chapter 5.

## PROGLI ST(*list mode*) (E788)

You can check how many steps and programs are still available (free).

Push “Enter” and the programs are shown in turns with its respectively steps, at the end “FREE%( ( ( ” shows the number of still available steps.

By *keeping the “NO” button pressed*, you do not proceed automatically and the display stays.

By pressing “ENTER”, the reading process is stopped and the number of free steps is indicated.

## PROG PRE (*pre-programmation mode*) (E619)

Here you can initialize the machine to its own technical characteristics (f.ex. coin meter or manual machine, number of water inlet valves, machine with or without heating, etc.) as well as certain free programmable options (f.ex. temperature in °C or in °F, temperature readable during the cycle on the display or not, etc.)

To modify the “preprogram” : see further in chapter 3.

**Remark :**

The “preprogram” is programmed by the constructor and should normally not be modified.

## LOG (*error indications*) (E605)

Here you can recall the last **20 error** indications. Press “-” or “+” each time in order to return or proceed to the previous or following error indication. Press “0” to leave the menu.

## HOURS(*working hours*)(E223)

Press “Enter” to see the number of working hours of a machine.

## TEST (*test mode*) (E217)

Here you can technically test the machine (see chapter 7).

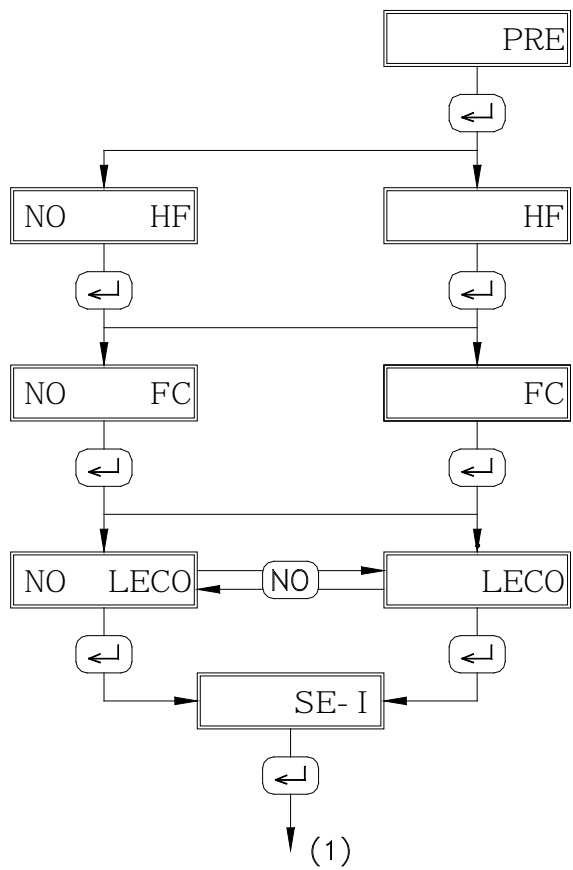



---

## Pre-programming

To open the "pre-programming mode": see 2. Division in modes.

In most cases, the selection is done by changing the order on the display if necessary by " NO " (ex. " no FC " and after pressing " NO ": " FC ") and confirming this with "ENTER".

While pre-programming, it is possible to return step by step by pressing '0' ( stop-key ).

PRE = Preprogram (altering the "Preprogram" )

Press "ENTER".

HF = Machine type HF, WE 245/304, or WE of the "washer extractors"

FC = Frequency controlled (with frequency controlled motor)

LECO = Level control (water level control)

Temporarily stopping the program until the correct water level is reached.

SE- I = Select inlet (selection of the water inlet valves).

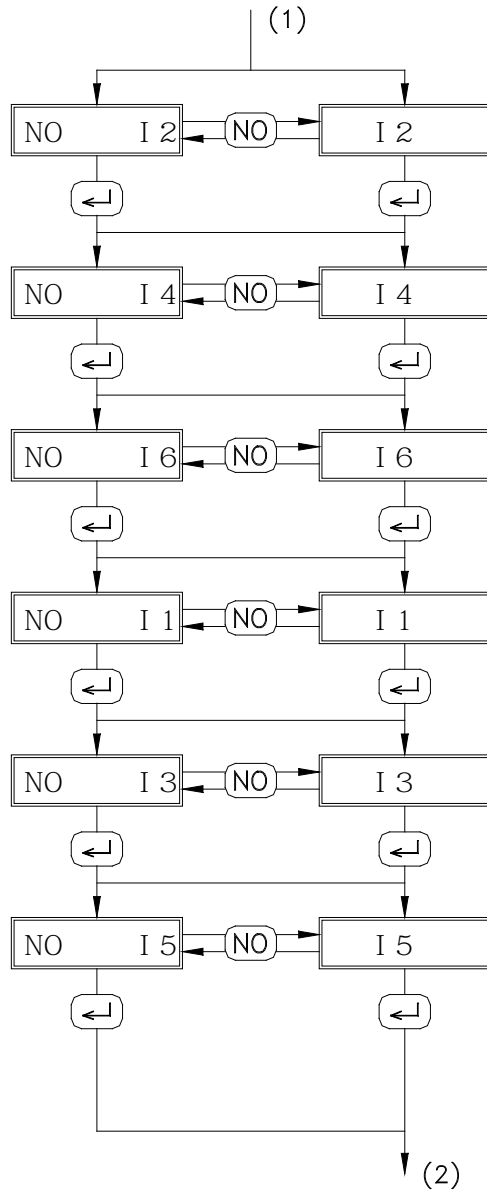
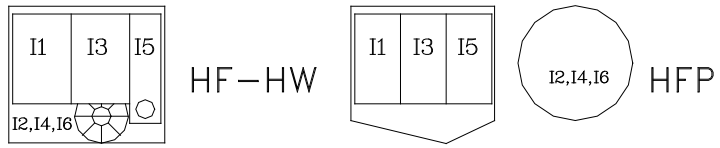

## HF - HW - HFP 3 soap supplies

I 2 Soft (tub)

I 4 Warm (tub)

I 6 Hard (tub)

I 1 Soft (prewash)

I 3 Warm (main wash)

I 5 Hard (softener)

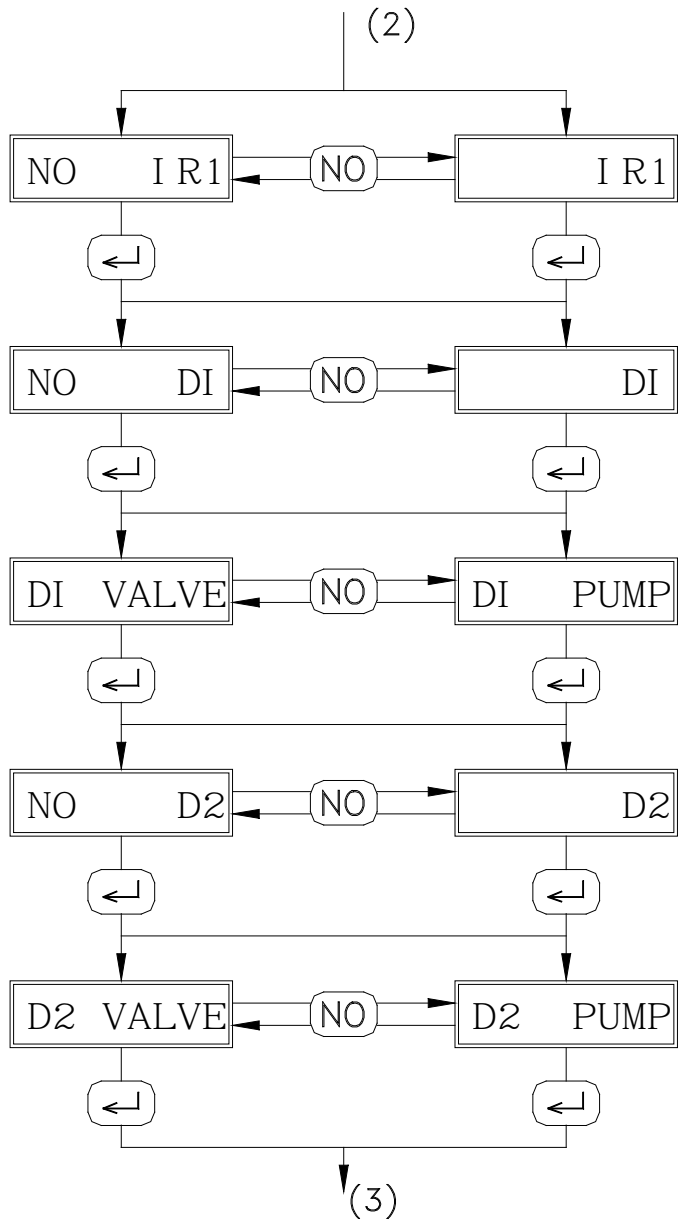

I R1                      Recuperation valve 1

D1                         Discharge valve 1

D1                         Discharge valve 1 or pump

D2                         Discharge valve 2

D2                         Discharge valve 2 or pump

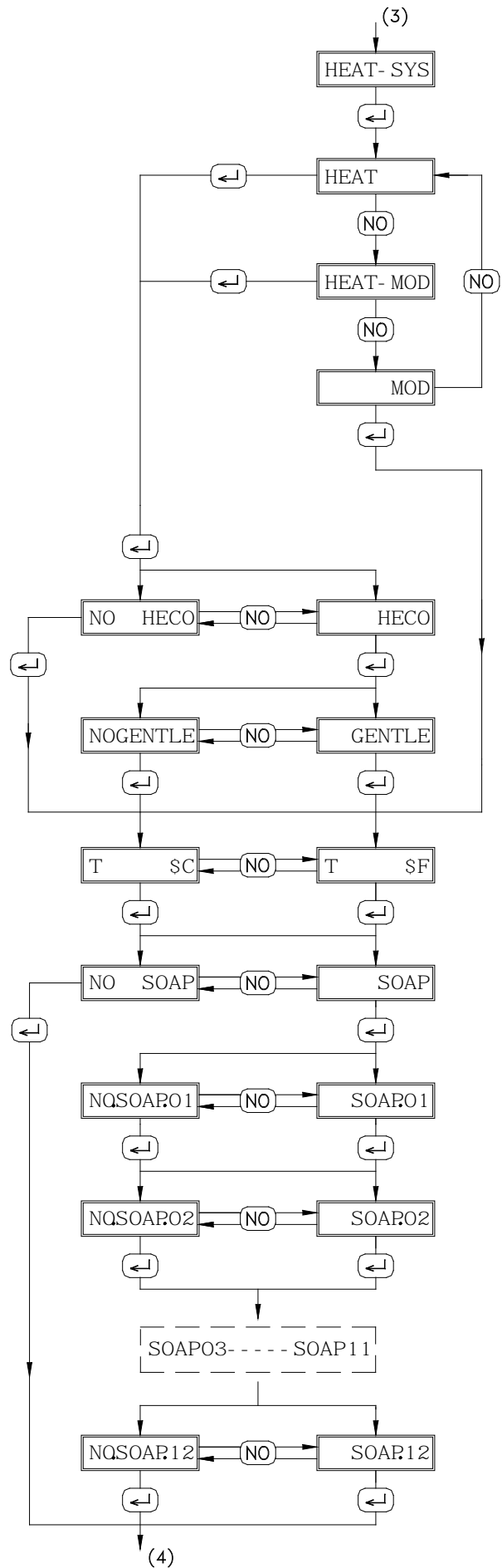

HEAT- SYS = Heating system

On machines with hot water supply, the *modulation technique* can be used. For this purpose, a *controlled water mixing* is applied during water supply, as a result of which the temperature of the bath after loading is perfect in most cases. If this option is not used, a traditional mixing system is used.

In following steps, you have to enter whether this modulation technique will be used or not.

Therefore, select from the following:

HEAT (heating system without modulation)

HEAT- MOD (heating system and modulation)

MOD (no heating system, only modulation)



---

If no hot water inlet valves are selected (see SE- I ) " HEAT " is automatically selected and " HEAT- SYS" will not be displayed.

---

HECO = Execute heating control (temperature control)

This means stopping the program temporarily during warm up, until the right temperature is reached.

GENTLE = Converting the movement time and the dwell time of the tumbler during temperature control.



---

If the machine is *not equipped with a heating system* ( MOD at HEAT- SYS), the functions HECO and GENTLE will not be displayed.

---

T \$C of T \$F = temperature selection in °C or °F.

SOAP = Injection pumps for liquid soap

If no liquid soap supplies are provided, continue with ADD

SOAP 01 = Soap pump 1

Soap injection via pump 1

On PS40, a maximum of 12 liquid soap supplies can be connected (standard 6 + 6 optional).

Select the desired soap supplies from SOAP 01 to SOAP 12 inclusive.

SOAP 12 = Soap pump 12

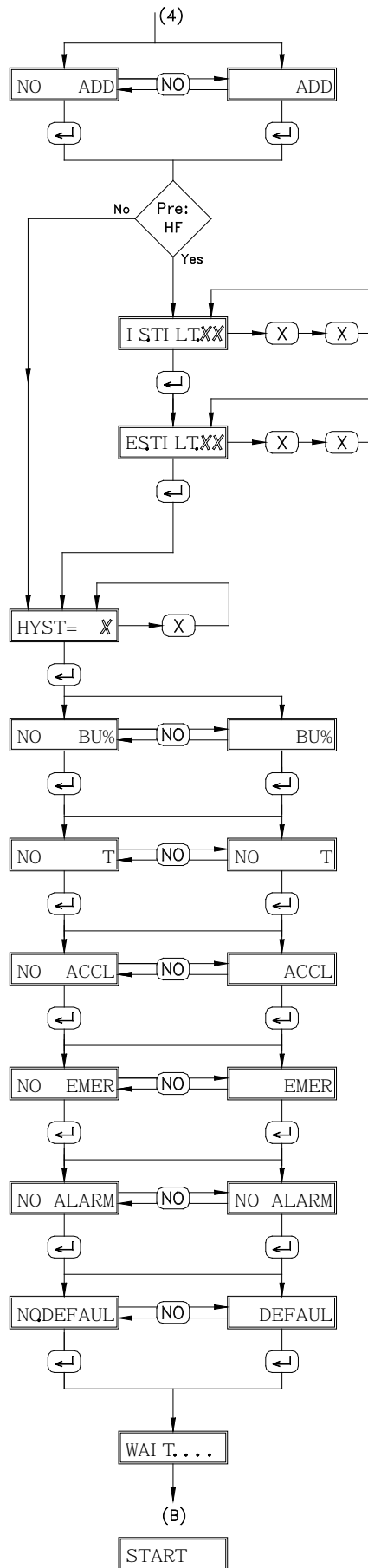



ADD = Additional programs

These are 3 options (Cool-down, time stop and a soaking program), which can be set later while programming. (see chapter 4)



On a machine type WE , you proceed directly to " HYST" .

I S. TI LT. **XX (Intermediate spin tilts)**

With " X,X " you can enter the number of tilting breaks that may occur during intermediate spinning (1 to 15) before skipping this spinning cycle.

ES. TI LT. **XX (End spin tilts)**

With " X,X " you can enter the number of tilting breaks that may occur during intermediate spinning (1 to 15) before skipping this spinning cycle.

HYST = Hysterisis

Here you can set the hysteresis (in °C) on the heating. The smaller the value, the more constant the water temperature will be, but the more frequent the heating element will switch off and on.

Enter the hysteresis with " X,X " (1-5°C).

BU% Buzzer (signal) at the end of the program

T = Temperature

Reading the temperature, visible on the display.

ACCL = Acceleration (to accelerate)

This allows running through the program quickly by means of the " E " key (in the "operation mode").

EMER = Emergency stop

The " STOP " key functions as emergency switch in the "operating mode".

ALARM

This way, an external source (horn or light) will be commanded, via outlet " **SOAP 6** ", which will announce f. ex. the end of a program or soaking cycle. This way, the number of soap exits will be reduced from 12 to 11.

DEFAUL= default

This parameter has no influence yet.

The pre-programming has finished now. " WAI T" appears temporarily. You'll return to " **StArt** ".

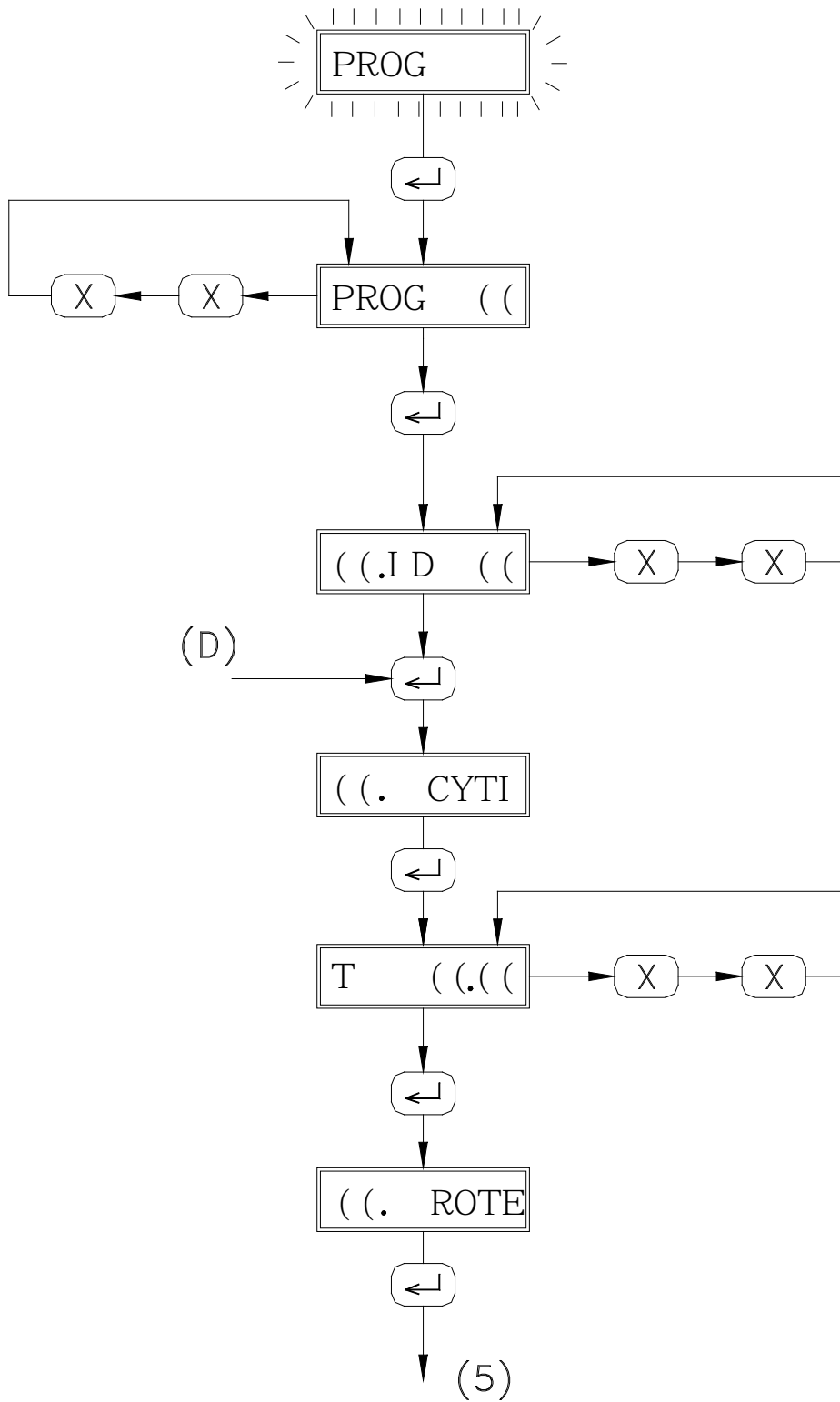

## Programming

To open the "programming mode", see 2. division in modes.

The selection can often be done by changing the order on the display if necessary with " NO " (f. ex. " NO HECO " and after pressing " NO ": " HECO "), and confirming this with "ENTER".

While programming, it is possible to return step by step by pressing " STOP " (stop-key).

PROG (blinking) = Programming

Press " ENTER ".

PROG ( = the program number that has to be programmed

Enter the desired program number with " X,X ".

On the **program number display**, the program number is displayed. In order to select a program number above 9, the number should be formed with a combination of keys.

Press " ENTER " again.

(( I D (( = "program number" and "program part number".

The first **XX** represent the program number entered at " PROG ".

The second **XX** represent the "program part number".

### Example:

" 02I D 03 " represents program 2, program part 3.

A program part is a part of a program (prewash, main wash cycle, rinsing etc.) and is **ended by a water discharge** in each case. In order to obtain a full wash cycle, several program parts should be entered consecutively. (max. 99 per wash cycle ).

Enter a program part number with " X,X " and press " ENTER ".



---

If during programming, there is insufficient space in the " RAM memory ", the error message " RAM FULL " will appear.

---

(( CYTI = Cycle time

This is the duration of the washing time in this program part (**XX**) ( without taken into account the temperature and level control )

**From now on**, " XX " stands for the program part number that has been entered.

Press " ENTER ".

T **XX.XX** = Time (Washing time in minutes and seconds)

Enter the time with " X,X " ( 0 to 60 minutes ) and press " ENTER ".

If " 0 " is entered, the program will proceed with " SPI N " (or " NO SPI N ").

(( ROTTE = Rotation (Dwell - and washing movement times)

Press " ENTER ".

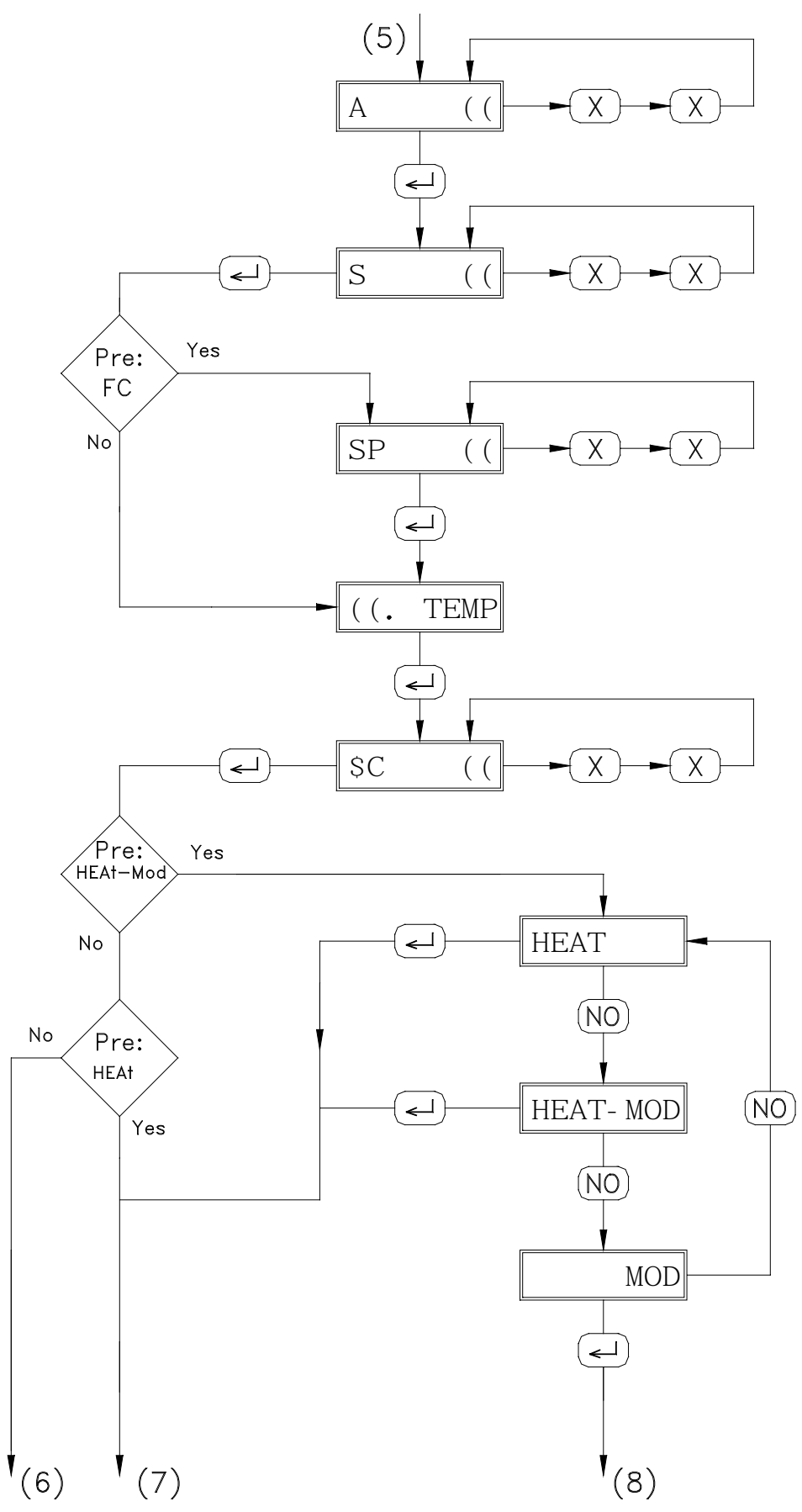

## A ( ( = Action time (movement time)

Enter the movement time with " X,X " (0 to 60 seconds).

When the motor frequency is controlled, a digit will appear after the decimal point and the time can be set accurately to 0.1 sec.

When "0" seconds is entered (cycle without movement of the drum), the following step (" S XX ") is skipped.

Press "E ".

## S ( ( = Stop time (dwell time)

Enter the dwell time with " X,X " (1 to 60 seconds).

When the motor frequency is controlled, a digit will appear after the decimal point and the time can be set accurately to 0.1 sec. (minimum 0.5 sec).

Press "E ".

The next step depends on the selection during the "pre-programming".

- Without " FC " (frequency controlled motor ): change to " XX. TEMP ".

- With " FC " ( frequency controlled motor ): change to " SP XX ".

## SP ( ( = Speed

Enter the revolutions per minute of the washing movement with " X,X " (10 to 50 revs/min)

Press " ENTER ".

## (( TEMP = Temperature (of the bath)

Press " ENTER ".

## SC (( = Temperature (Or " \$F (( " °C or °F according to your selection in pre-programming ).

Enter with " X,X " the temperature (*maximum 95°C*) and press " ENTER ".



In case of a cold bath, enter "0". Proceed with " XX. SE-i " immediately.

The following step depends on the selection made in "preprogram" during " HEAT- SYS ".

➡ If " HEAT- MOD " was selected, you can now make a selection with " NO " switched off:

HEAT (heating without modulation) transition to " HECO " or " (( SE- I ".

HEAT- MOD (modulation with supplementary heating) transition to " HECO " or " (( SE- I ".

MOD (modulation without supplementary heating) transition to " (( SE- I ".

Press " ENTER ".

➡ If " HEAT " was selected, there will be an immediate transition to " HECO " or " (( SE- I ".

➡ If " MOD " was selected, there will be an immediate transition to " (( SE- I ".

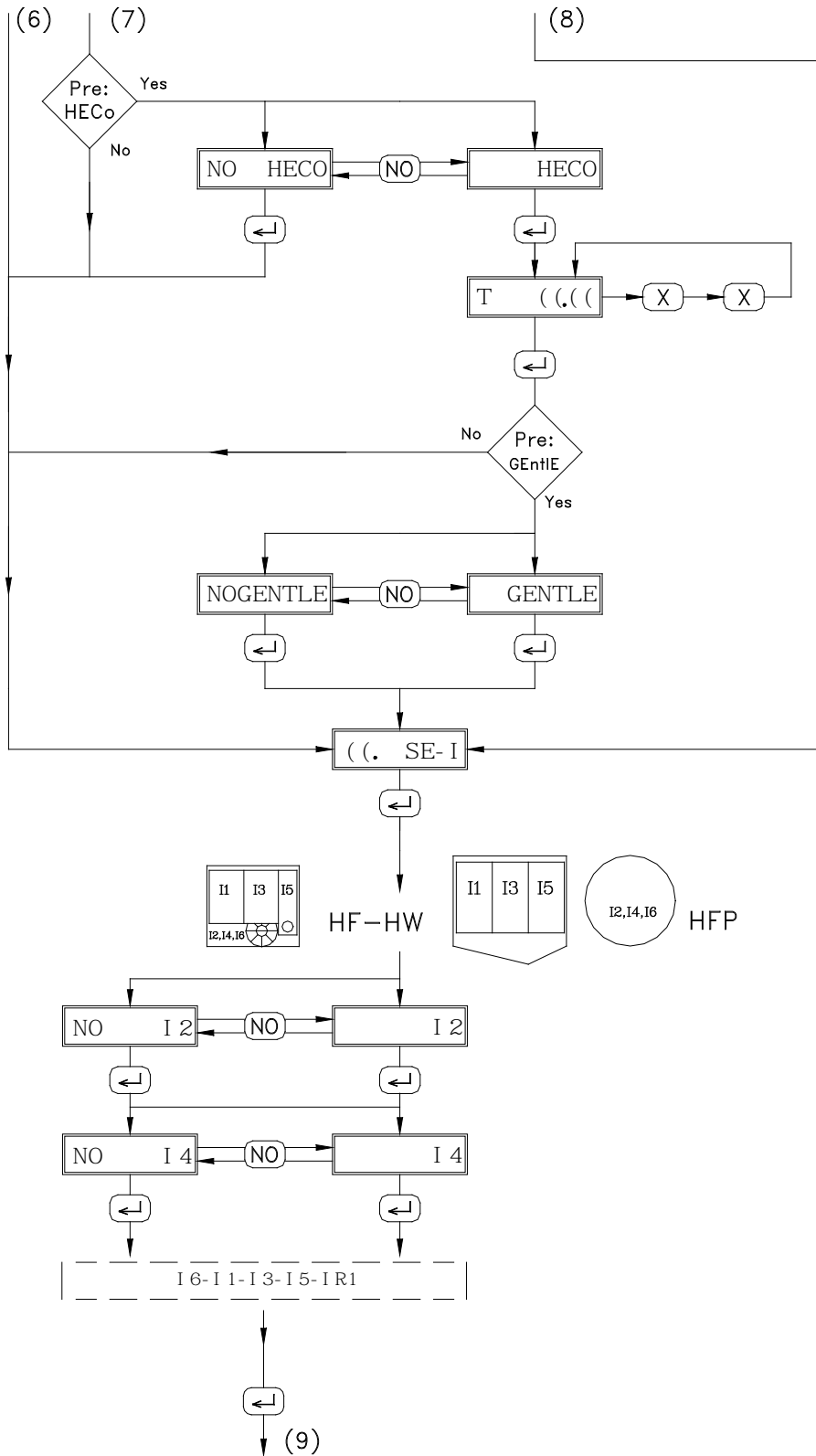

HECO = Heating control

If no heating control is wanted, select " *no HECo* " and press " ENTER ".

If heating control is desired, select " HECo " and press " ENTER ".



If " NO HECO " is selected, there will be a transfer to " ( ( SE- I ".

---

T **XX** = Time (duration of temperature control)

With " X,X ", enter the time when the control should be performed (value between 0 and the washing time entered at " ( ( CYTI " ) and press " ENTER ".

GENTLE = converting the movement and dwell time (set at " A **XX** " and " S **XX** ") *during temperature control*.

" ( ( SE- I " = Select inlet (select water inlet valves)

Press " ENTER ".

I 2 = Inlet 2 (inlet valve 2) (**HF**) or *i1* = Inlet 1 (inlet valve 1) (**HFP machine**)

With " NO ", select whether an inlet valve should be selected or not.

Press " ENTER " to continue with the next inlet valve.

To save space, not all valves have been drawn. The action is the same for each one of them.

You can find the function of the valves in chapter 3.



If, by mistake, you selected the wrong inlet valve and the temperature should rise *above* the " \$C **XX** " set, cold water will automatically flow through inlet valve " i2 " (**HF**) or " i4 " (**HFP**) for safety.

---

The following step depends on the selection made at "preprogram"

- without " SOAP " (liquid soap supply) : transfer to " ( ( SE L ".

- with " SOAP " (liquid soap supply) : transfer to " SOAP " (or " NO SOAP ").

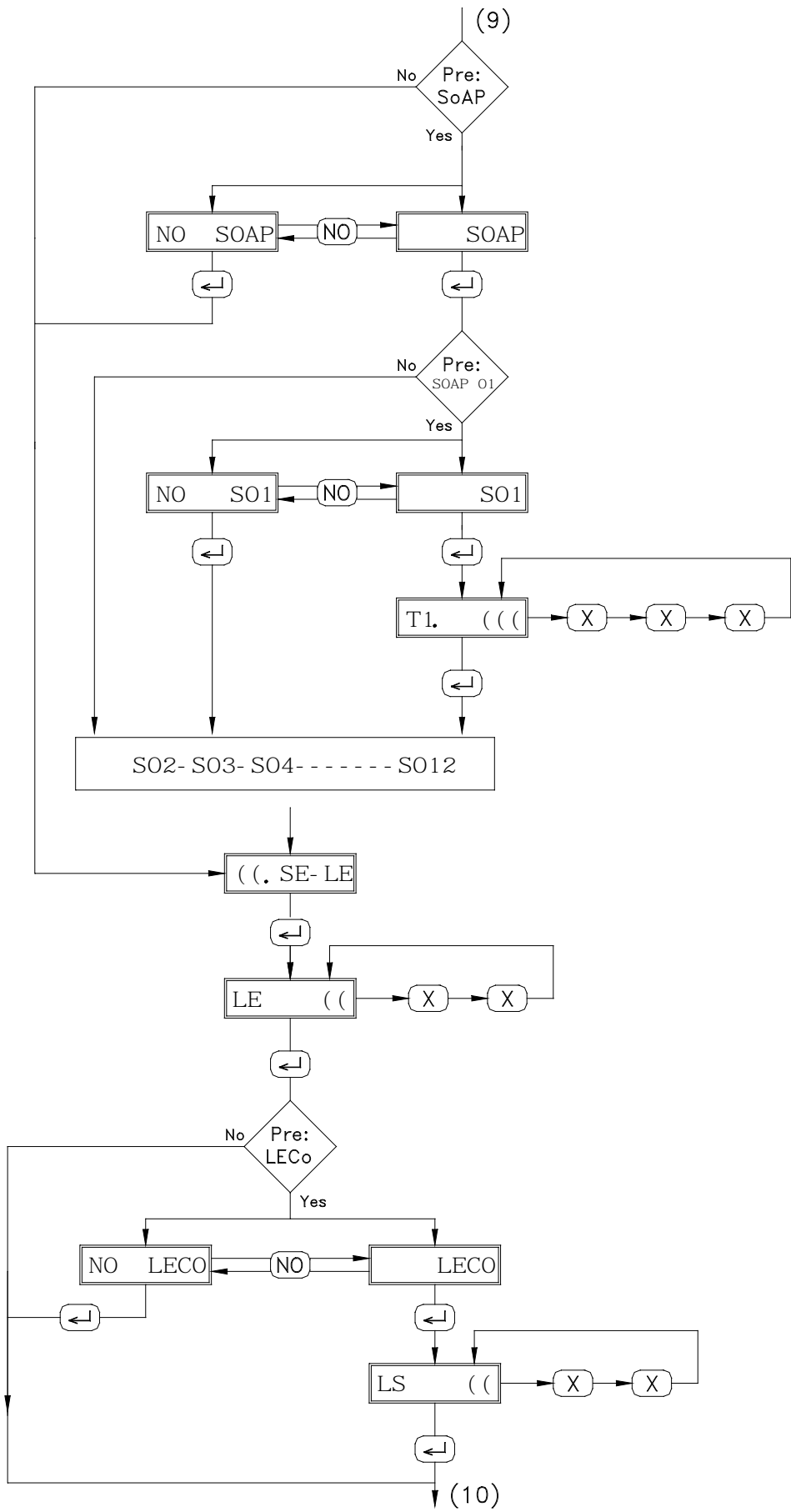



# Programming mode

## Programming mode

4

SOAP= Liquid soap supply

If no soap injection is desired, select "NO SOAP" and press "ENTER". (Transfer to "( ( SE- L ")  
If soap injection is desired, select "SOAP" and press "ENTER".

The program will proceed with the first soap inlet activated in the "preprogram".

Example: "SO1" (Soap 1)

SOI = Liquid soap injection 1

Use "NO" to choose whether a soap inlet pump should be selected or not.  
Then press "ENTER".

T1 ( ( (= Time 1 (duration of soap injection 1)

Enter the duration with "X,X,X" (maximum 999 seconds).  
Press "ENTER" to proceed to the next soap injection.

Depending on the selection in "preprogram", the soap inlets can be programmed one after the other (from SO1 to SO12 included).

In order to save space, only SO 1 was drawn, the others are identical.



---

Press "Enter" after setting the soap inlets.

( ( SE- L = Select level (select water level)

Press "ENTER"

LE ( ( = Level (Water level)

Use "X,X" to enter the level (5 to 50) (experimental) and press "ENTER".

The next step depends on the selection made during "pre-programming"

- without "LECO" (level control): transfer to "ADD" (or "NO ADD")

- with "LECO" (level control): transfer to "LECO" (or "NO LECO")

When "OS" is entered at "( ( TEMP", you can enter a level between 0 and 50.



---

**Overflow** (extremely soiled linen).



- enter "OSC" (or "SF") at "( ( TEMP"

- select "NO HECO" and enter the level "OO" at "L ( ( "

During the **complete washing time**, water will be supplied and discharged **via the overflow**.

---

LECO = Level control

If no level control is desired, select "NO LECO" and press "ENTER".

If level control is desired, select "LECO" and press "ENTER".

LS ( ( = Level stop (level control)

With "X,X", enter the level where the program time should stop (automatically limited) till the set value is reached at "LE ( ( "

When this level is reached, the programmer continues and the bath is filled till the level set at "L ( ( " is reached. Press "ENTER".



The next step depends on the selection during "pre-programming".

- Without "Add "(help program), transition to "SPI N "(or "NO SPI N ").

- With "Add "(help program), transition to "ADD "(or "NO ADD ").

ADD = Additional program (program extension)

When no program extension is desired, select "NO ADD " and press "ENTER "(transition to "SPI N").

If a program extension is desired, select "ADD " and press "ENTER ".

With "NO" switched off select: "COOL ", "STOP ", "STOP ( ( ( ", "SOAH ( ( ( ", or once more "no Add " and press "ENTER " to confirm your selection.

## ➔ COOL = Cool-down

CD' & ( ( = degree of temperature drop to the highest cool-down temperature

Enter the degrees of temperature drop at "X,X" (1 to 99 °/minute) and press "ENTER ".

CDU ( ( = highest cool-down temperature

With "X,X" enter the temperature (30 to 85) and press "ENTER ".

CDN& ( ( = degree of temperature drop to the lowest cool-down temperature

With "X,X" enter the degree of temperature drop (1 to 99 °/ minute) and press "ENTER ".

CDN ( ( = lowest cool-down temperature

With "X,X" enter the temperature (30 to 85 and automatically limited to the value set at "CDU ( ( ") and press "ENTER ".

## ➔ STOP = Stop

In the "operating mode ", the program will stop here, so f.ex. extra soap could be added manually (the water remains in the bath). See operating mode: "programmed stop "

A "stop time " up to **999** minutes can be entered. After this stop time has expired, the program will **automatically** restart.

STOP ( ( (

With "X,X,X" enter the stop time (**0 to 999 minutes**) and press "ENTER".



If "0" was entered, the program will be stopped until "START " is pressed.

## ➔ SOAK = Soak

In the 'operating mode, the program will stop here, the level will be brought to "25 " and every 3 minutes, a left - right movement will be performed (temperature will remain constant).

See operating mode: "soak ".

You can enter a "soaking time " from up to **999** minutes. After this soaking time is up, the program will **automatically** restart.

SOAK ( ( (

With "X,X,X" you can enter the soaking time (**0 to 999 minutes**) and press "ENTER ".



If "0" was entered, the program will be stopped until "START " is pressed..

ALARM ( ( (

In the beginning of this soaking time you can activate the alarm signal.

With "X,X,X" you can enter the time (0 to 250 secs) during which you want to hear the signal.

This option can only be displayed if the preprogram is selected ( see "ALARM").



If "999 " was entered, the alarm will be active during the complete soaking time!

## ➔ NO ADD = No additional (no program extension)

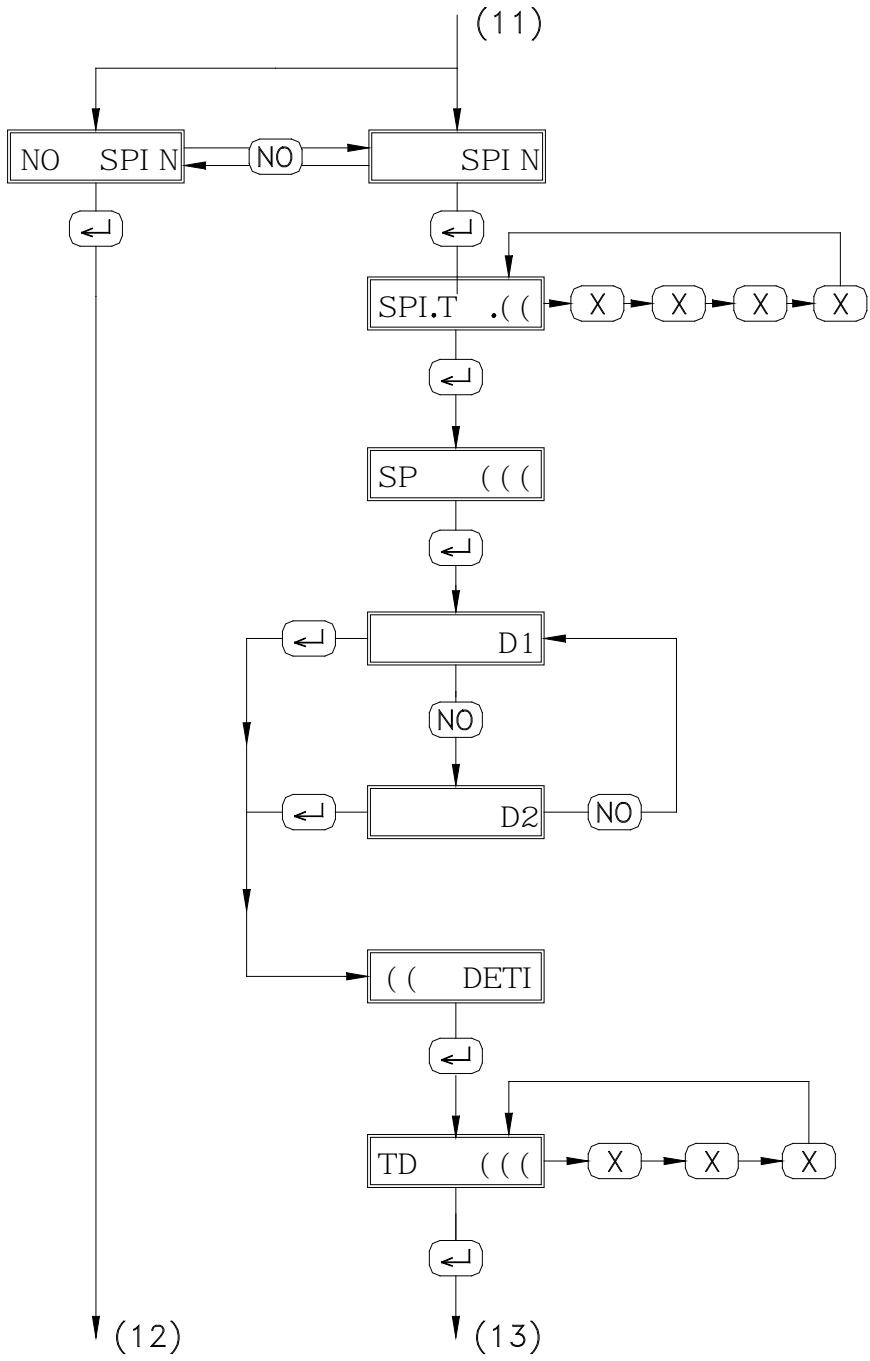

SPI N = Spinning (extraction)

If spinning is desired, select " SPI N" and press " ENTER ".

If no spinning is desired, select " NO SPI N" and press " ENTER ". (transition to " dO ", " d1 " or " D2", ...).

The next step is dependent upon the type of machine:

With frequency controlled motor

SPI T ( ( = Spin time (duration of spinning)

With " X " enter the duration of the spinning  
(1 to 15 minutes) and press " ENTER ".

SP ( ( ( = Speed (spinning speed)

With " X,X,X,X " enter the number of revolutions  
of low spinning (250 to 1000 revs / min) and  
press " ENTER ".



On machines with drum diameter higher than  
850 mm, this value is limited to 800.

DI = Drain 1 (drain valve 1)

Select " D1 " , " D2 " with  
" NO " " and confirm with " ENTER ".



The number of drain valves from which you  
can choose, is dependent upon the setting of  
the pre-program.

(( DETI = Delay time (clearance after  
spinning)

Press " ENTER ".

TD ( ( ( = time delay (clearance time)

With " X,X,X " enter the time and press  
" ENTER ".

Time to enter:

30 to 180 secs after spinning below

500 revs /min

60 to 180 secs after spinning above

500 revs / min

Without frequency controlled motor

SPI - ( = Low spin time

With " X " enter the duration of low spinning  
(1 to 9 minutes) and press " ENTER ".

DI = Drain 1 (drain valve 1)

Select " D1 " of " D2 ", or " NO " " and confirm  
with " ENTER ".



The number of drain valves of which you can  
choose, is dependent upon the settings of the  
pre-program.

(( DETI = Delay time (clearance time after  
spinning)

Press " ENTER ".

TD ( ( ( = time delay (clearance time)

With " X,X,X " , enter the time and press  
" ENTER ".

Time to enter:

30 to 180 secs after low spinning.

60 to 180 secs after high spinning.

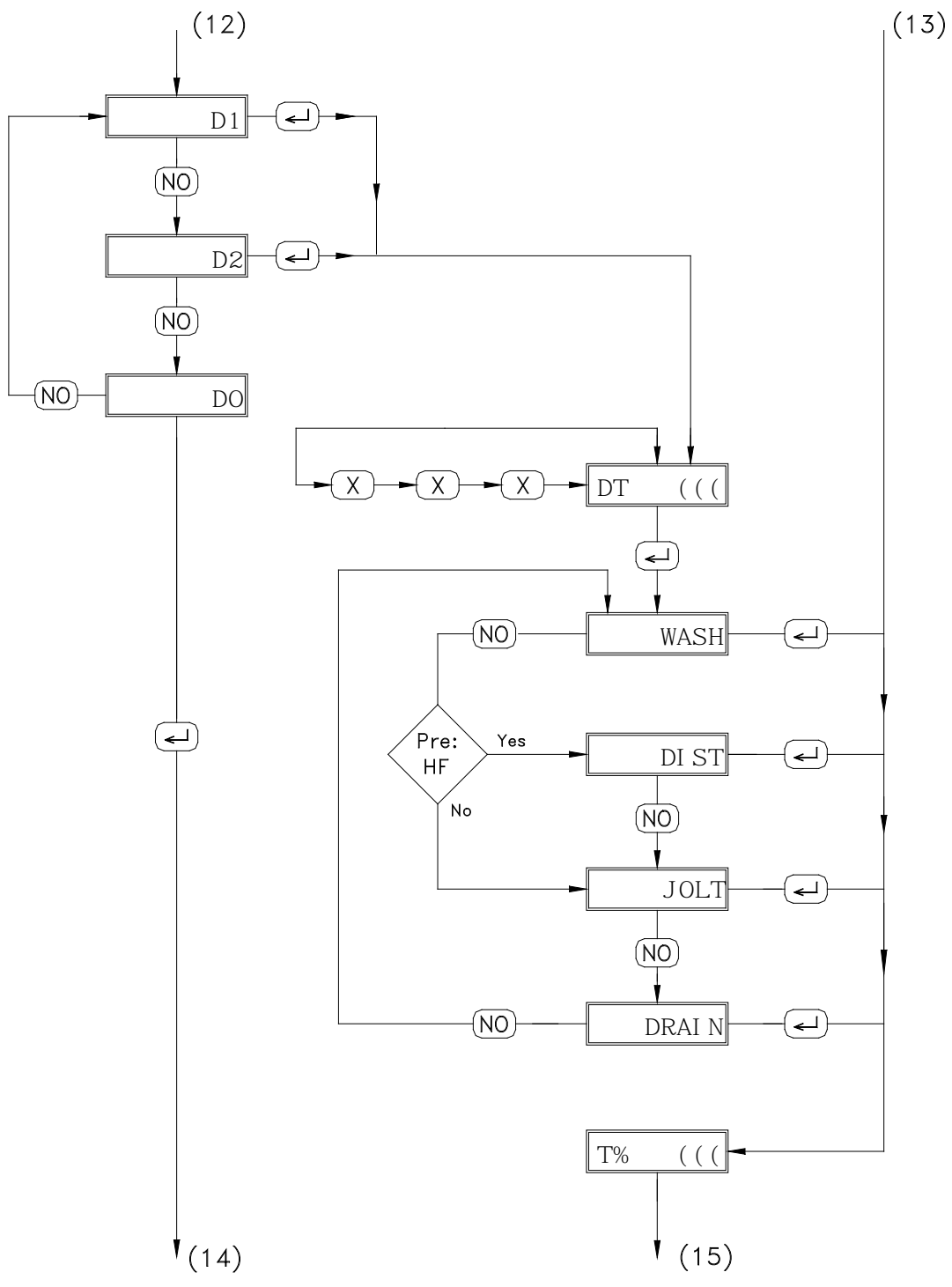

DI = Drain 1

Select " D1 ", " D2" of " DO"met " NO " and confirm "ENTER ".

When "DO" is selected, the water will not be discharged (transition to the next program part)



The number of drain valves of which you can choose, is dependent upon the setting of the preprogram.

---

DT ( ( ( = Drain time

With " X,X,X " enter the drain time (max 180 secs) and press " ENTER ". With " NO " select from " WASH ", " DI ST ", " JOLT" and " DRAI N " which action should be performed in between two discharges and confirm with " ENTER " .

WASH = Washing movement

➔ Washing movement of the drum during water discharge.

DI ST = Distribution (distribution speed) (not on machines of the type WE (NO HF))

➔ Distribution movement of the drum during water discharge.

➔ JOLT = Short spinning ( after distribution, low spinning for 10 secs )



At " DT ( ( ( " enter a minimum of **60** secs

---

DRAI N = discharge

➔ Water discharge without movement of the drum

T= ( ( ( ( = Time

This is the duration of the program part.

Press " ENTER ".

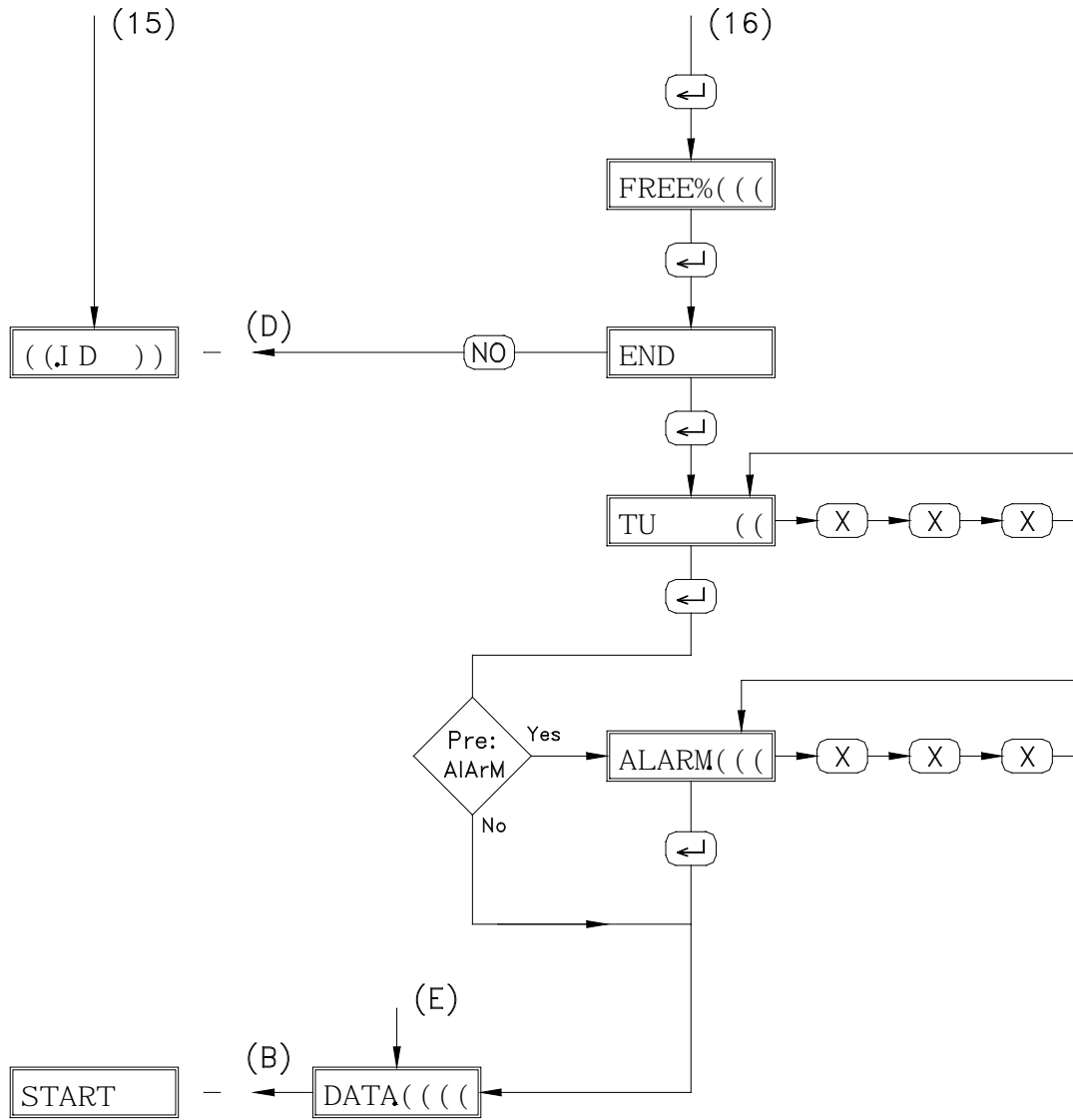



FREE% ( ( = the maximum number program parts to program.

You can program 400 program parts at the most .  
Press " ENTER " .

END = end of a program part.

Press "NO " to proceed with the next program part ( transfer to " ( ( . I D ) ) " ) . ) stands for the following program part number.  
Press " ENTER " to set the end of the program.

TU ( ( = Tumble (untwining)

This is being executed in a washing rhythm of 60 secs of action and 9 secs of stop time. The lowest speed that occurs in this program is being used (on frequency controlled machines).  
With " X, X, X ", enter the tumble time (30 to 999 secs) and press " ENTER " .  
If no untwining is needed, you can enter 0. A dwell time of 1 minute is then performed.

ALARM ( ( (

Here is where you can activate the alarm signal.  
With " X,X,X ", enter the time (0 to 250 secs) during which you want to hear the alarm.  
This option is only displayed when selected in pre- program (see "ALARM").



---

If " 999 " was entered, the alarm will remain activated until the door is opened.

---

DATA ( ( ( (

At the end of the programming, the new " checksum " is displayed ' during a couple of seconds, then you proceed with " *Start* " .

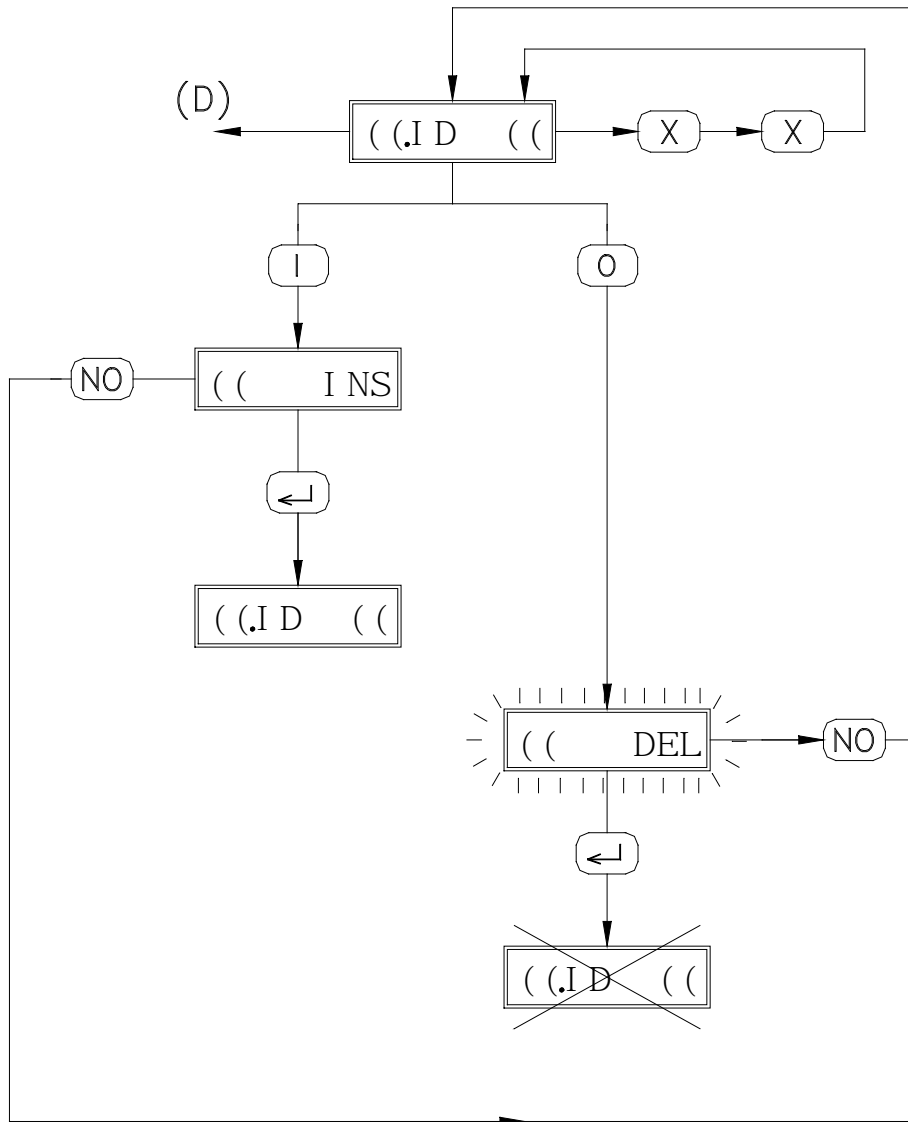

## Inserting and deleting a program part

Start the programming procedure till " ( ( I D ( ( " .

### ➔ **Inserting a program part.**

Press " START " .

#### **XX. inS = Insert**

Press " ENTER " .

The program part " **XX** " is advanced with one position. " ( ( I D ( ( " reappears on the display. This program part can now be re-entered.

Example:

Program " 01 " with 4 program parts (01,02,03,04)

Between 02 and 03, one program part has to be inserted.

Select " 01 I D 03 " and press " START " . " 03 I NS " reappears on the display . Press " ENTER " .

" 01 I D 03 " reappears. Program part " 03 " should now be re-entered. The previous part " 03 " has moved on to " 04 " and " 04 " has moved on to " 05 " .



If there should be insufficient space in the Ram memory, the error message " RAM FULL " will appear.

### **Deleting a program part**



Press " STOP " .

( ( DEL (blinking) = Delete

Press " ENTER " .

The program part " **XX** " is being deleted. The following program parts are moved back with one position.

Example:

Program " 01 " with 4 program parts (01,02,03,04,)

Part 02 has to be deleted.

Select " 01 I D 02 " and press " STOP " . On the display appears " 02 DEL " . Press " ENTER " .

Now, " 01 I D 02 " reappears. This used to be program part " 03 " .

Program part 04 has been moved back to 03.

## **Program tables**

The table on the following pages shows how the programmed data have been saved.



Copy the blank tables on the pages for as many times as there are programs to be set. Fill them in and save them carefully.

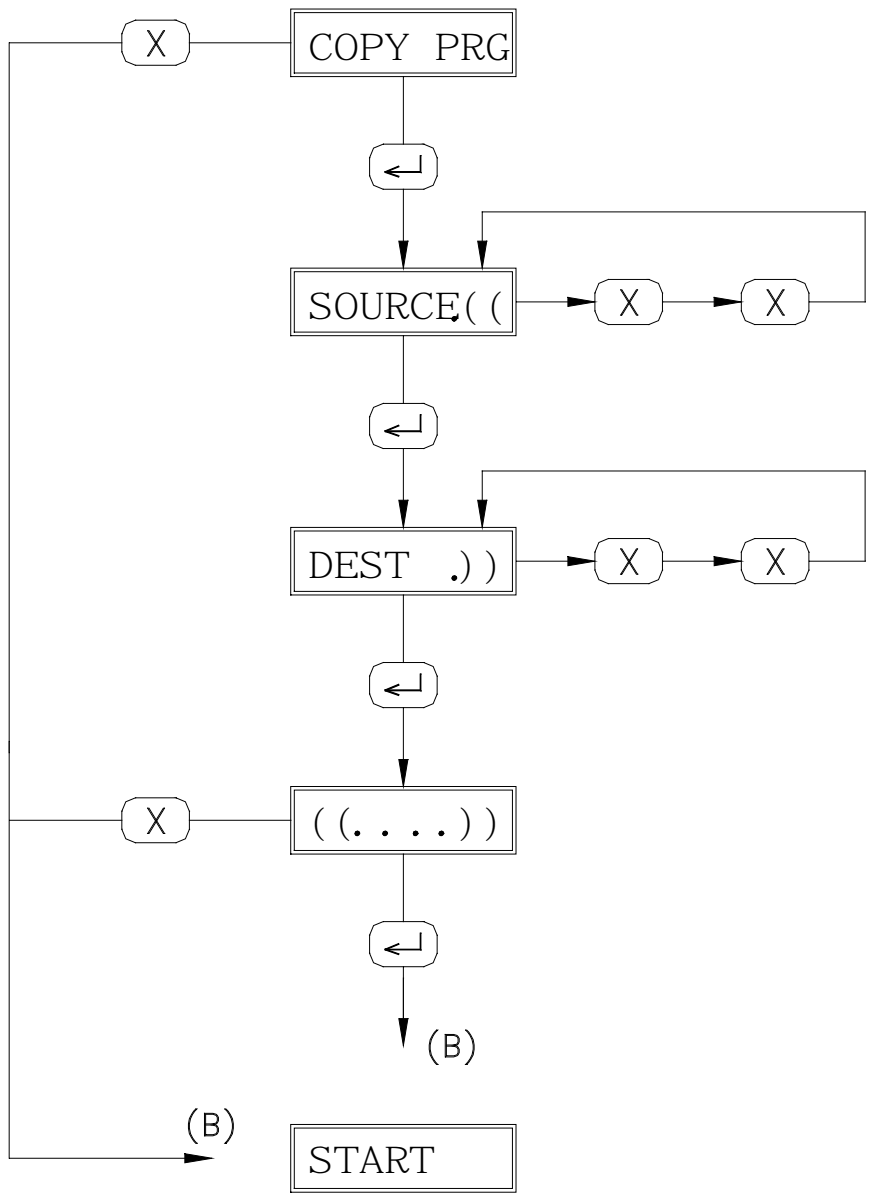

---

## Copying mode

To go to the " copying mode ", see 2. Division in modes.

The PC40 programmer is fitted with **10 fixed standard programs** (40 to 49). These programs can be executed directly.

At these locations however, it is **impossible to change** them. If you want to change them or use them as the basis of another program, you need to **copy them first to a new program number** between 0 and 39. (see further).

Other already self-programmed programs can also be copied to another number (between 0 and 39) in the same way and then be used as a basis for other programs. In this way, you can save a lot of time when creating programs that are much alike.

COPY PRG = Copy program

To confirm, press " ENTER ".

To cancel, press any key ( transition to " START")

SOURCE. ( ( = program to copy

With " X,X " , enter the program number and confirm with " ENTER ".

DEST. ) ) = Destination (destination of the copied program)

With " Y,Y " , enter a program number and confirm with " ENTER ".

(( - - )) = Confirmation of copy

To confirm: press " ENTER " (transition to " START ")

To cancel: press any key ( transition to " START")



---

If there should be insufficient space in the RAM memory, the error message " RAMFULL " will appear.

---

-----

## Standard programs

On the pages at the back of the manual, you'll find the composition of the standard programs according to the different machine types.

To go to "operating mode": see 2. Division in modes.

## Selecting a program

PROG ( (= Program XX (ex. program 01)

If necessary, select another program number.

The program number is shown on the display.

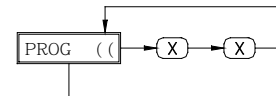

➔ To select a program number above 9, you need to enter the number as a combination.

Example: Program 25 : enter " 2 " + " 5 "

## Starting a program

Press " I ".

The program is now started.

" XX.XX'XX " appears on the display ( f. ex. " 01.41'15 " ).

01 = *program part number*

41' 15 = *total resting programming time*

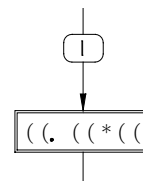

When the door hasn't been shut properly, the message " *door. oPEN* " appears.

When a program number has been selected, which isn't linked with a program yet, " A2 " is blinking on the display during 10 seconds.

## Course of the program

During the program, the program time will count down per seconds.

After a program part has been performed, the next program part number appears.

" XX.XX'XX. " (e.g.: " 01. 41' 15. ")

When water is being supplied, the first decimal point will illuminate.

As long as a level control is being performed at the same time, this decimal point *will blink*.

" XX.XX'X.X " (e.g.: " 01. 41' 1.5 ")

When the water is heated, the second decimal point will illuminate.

As long as a temperature control is being performed at the same time, the decimal point *will blink*

" XX.XX'.XX " (e.g.: " 01. 41'.15 ")

When the water is being discharged, the third decimal point will illuminate.

As long as a distribution control is being performed at the same time, the decimal point *will blink*.

" XX.XX'.XX " (e.g.: " 01. 41'. 15 ")

When high spinning, the fourth decimal point will illuminate.

When low spinning, this decimal point *will blink*.

" P( ( END "

When the entire program has been executed " P( ( END " appears (f.ex.: " P01 END") and the buzzer will be activated for about 10 seconds (if the buzzer " BU%" has been selected " in "preprogram").

On programs where an alarm signal has been programmed, (ALARM( ( ( ) this is now being executed.

When the door is opened, " START " appears.

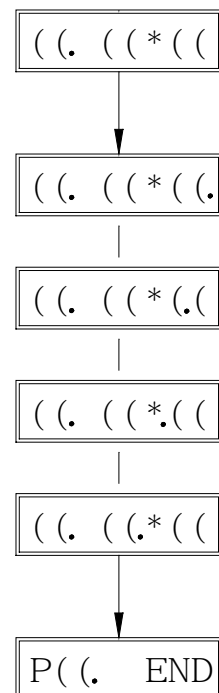

## Programmed start

Press " START " and keep it pressed for more than 5 seconds after a program has been selected.  
" dELAY.XX " appears on the display.  
By entering a digit between 0 and 99, the start can be postponed per hour.  
Press " START " again to start the count down (the decimal point blinks).  
In the last hour, the minutes are blinking on the display.

### Remark:

To stop the countdown: press " STOP ".

## Changing the program

The first 3 minutes after starting, you still have the possibility to change the program. Enter another program number.  
" P. ( ( . START " will appear on the display. " P. ( ( " represents a new program number.  
Press " START " to confirm.

### Remark:

On machines with coin (if a more expensive program has been selected), the amount due " ( ( ( . ( ( " appears.  
The first program keeps running till the coins are inserted. If this doesn't happen, the program will continue 3 minutes after the first start.

## Changing the level, the washing time and the temperature settings once.

Select the program number.

**Before starting the program**, press " NO " and " ENTER " at the same time.

Per program part, first the level " L ( ( ", the washing time " T ( ( " and then the temperature " \$C ( ( " appear on the display. Change these data if necessary and press " ENTER " to proceed with the washing time and temperature settings of the next program part.

Start the program with " START " after the setting have been modified.

### Remark:

The value of " LECO" en " HECO" is being changed downward with the same value till a minimum of "00 " is reached.

The program will only be executed once with the settings modified in this manner. This function cannot be realized on machines with coins.

## Controlling the temperature of the bath and the number of revolutions

By pressing the " NO ", you can read the temperature of the bath and the number of revs for 5 seconds.  
These functions are only operative if temperature reading ("T") has been selected in "preprogram".

- ➔ **Press once:**  
The temperature of the bath is given, followed by a horizontal line. (T=( ( \$C\_ ) ).
- ➔ **Press twice:**  
The highest temperature in the program is given, followed by two horizontal lines (T=( ( \$C%).
- ➔ **Press three times:**  
The highest temperature in the program is given, followed by three horizontal lines (T=( ( \$C%).

### Remark:

When the temperature measured is less than 25 °C, the message " COLD " is displayed.

- ➔ **Press four times:**  
*On machines with frequency controlled motor* ( " FC " in "preprogram", the number of revolutions is given ).

## Controlling the program during functioning

By pressing " NO " *longer than 3 seconds* and then releasing it, all set steps per program part are displayed one after the other *during 1 second*.

By pressing *and holding* " NO " once more, *the step performed last* is displayed. After releasing the " NO ", the next steps are given.

At the end of the program part, " ENTER " appears during 3 seconds. In order to proceed with the reading of the next program part, " ENTER " should be pressed within that time. If not, the normal course of the program is displayed.

## Running through the program quickly

While pressing , the program will be accelerated (if accelerate (" ACCL") was selected in "preprogram").

The seconds are counted down faster. The acceleration is interrupted at every major step of the program (discharge, cool down, etc.) Press the acceleration key once more to continue more rapidly.

In this way, you have the possibility not to execute certain parts or the rest of the program.

During *tumble*, the program cannot be accelerated.

## Programmed stop

When a " stop " has been programmed, the program will stop there. The water remains in the drum, there are no drum movements and " STOP " appears on the display.

After pressing " START ", the program continues

➔ Stop with stop time.

If a *stop time* has been programmed, " STOPTI ME " and the counting down remaining stop time will alternately appear on the display. After the stop time has expired, the program time will continue automatically. The machine stops until " START " is pressed again.

➔ Alarm signal.

If an alarm has been programmed, this will be activated at the beginning of the stop. This signal can be stopped by pressing " START " or " STOP ".

## Soaking

If " SOAK " has been programmed, the program will stop there. The bath will be brought to level 25, kept at the right temperature and every 3 minutes there will be a left - right movement.

The soaking continues till " START " is pressed.

➔ Soaking with soak time.

If a soak time has been programmed, " SOAKTI ME " and the counting down remaining soak time will appear alternately on the display. After the soak time has expired, the program time shall continue automatically. If, during this soak time, the START - key is being pressed, the program will be proceeded immediately.

➔ Alarm signal.

If an alarm has been programmed, this will be activated at the beginning of the soak time. This signal can be stopped by pressing " START " or " STOP " .



## Time stop (not on machines with coins)

By pressing the "STOP" button longer than 3 seconds, the program comes in "*time stop*" (if "EMER" was selected in the "pre-program").

With this you can for instance extend a program for very dirty linen. The time is stopped and the step is continuously executed. The programmed water level and temperature are maintained. During the "time stop", "( ( TI STOP" is indicated.

Now you can possibly program the stop time. Therefore, press "ENTER". Now, "( ( TI ( ( " is indicated. Program by means of "X,X,X" the stop time (from 1 to 999) minutes and press "E".

The display shows by turns "( ( TI STO" and the counting stop time left. Once the stop time is passed, the program time continues automatically.



If no stop time is programmed, the stop will be executed continuously until "START" is pressed.  
A "time stop" during the spin is automatically broken off after 20 minutes.

## Break off or stop a program

When the "STOP" button is shortly pressed, the display text blinks and the water is evacuated after 5 seconds (only if emergency stop ("EMER") was selected in the "pre-program"). The buzzer starts after 30 seconds, "OPEN DOOR" appears and the door has to be opened. Afterwards "CLOSE" appears.

When the door is locked again, you can :

- continue the program by pressing "START"
- stop the program permanently by pressing "STOP".



The stop function operates during spin1 with 60 seconds delay and during spin2 with 120 seconds delay.

## Add water

By pressing first button "1" and then one of the buttons from "1" till "9" during a program, the corresponding inlet valve is opened.

By pressing first button "2" and then one of the buttons from "1" till "3" during a program, the corresponding inlet valve is opened.

While pressing, the chosen inlet valve and level are shown, "I ( L( ( ". This indication lasts for 3 seconds after releasing.



These functions do not operate during the first **3 minutes** of the program.

## Water exhausts

By pressing first the "0" button and then one of the buttons from "1" till "4" during a program, the corresponding exhaust valve is opened.

While pressing, the chosen exhaust valve and level are shown "D( L( ( ". This indication lasts for 3 seconds after releasing.



This function does not operate during the first **3 minutes** of the program.

## Warm up the bath

By keeping the button "4" pressed during a program, the heating is activated (max. 95 °C). While pressing, the temperature of the bath "SC ( ( " (or "of SF ( ( ") is shown.



This function does not operate during the first **3 minutes** of the program.

## Adding soap (not on machines with coins)

By pressing first button “3” and then the “+” button, “SO( T( ( ” is indicated. By keeping one of the buttons from “1” to “9” pressed then, soap is added through this entry. With button “0”, “-”, “+”, soap can be added through entry 10 till 12. While pressing, the selected soap entry and time when the soap has been added are indicated.



This function does not operate during the first **3 minutes** of the program.

## Error indications

When there has been a technical failure during a program, " A( " or " F( " will be indicated at the end instead of " P( ( END ".

- " A0 " : the program key was in the wrong position when trying to access the programming mode.
- " A3 " : the machine has not been set up (preprogram) or the memory has been lost.
- " A4 " : the filling time was longer than 15 minutes.
- " A5 " : the requested temperature was not achieved after 60 minutes of heating.
- " A6 " : the temperature in the cylinder is unsafe at the end of a program (Temperature > TES in configuration file). Wait until the load cools to prevent burns.
- " F6 " : the doorlock was unbolted.
- " A7 " : **there is still water in the tub at the end of the program** (door cannot be opened).
- " A8 " : the temperatur sensor was not operating.
- " A9 " : the heat motor security was switched on during the program (not for frequency controlled machines).
- " AC " : the water was not evacuated after 3 minutes : there was no further heating.
- " AD " : no rpm were measured during the spin (only for frequency controlled machines).
- " AH " : the spin was not executed (max. number of tilts was exceeded).

These indications disappear after opening the door.

Certain error indications are directly shown and prevent the start of the cycle or stop the cycle.

- " A2 " : an unknown program was chosen.
- " F1 " : invalid control configuration / wrong configuration file / corrupted PS40 firmware.
- " F5 " : the door was opened during the program.
- " AB " : water level has still been detected at the start of the program.
- " F6 " : the doorlock was unbolted during the program.
- " FA " : the tilt switch is blocked.
- " FH " : hardware error (fault at printed circuit board).

These error indications disappear when the error is repaired.



The test mode is set up to help finding technical failures and is *rather made for specialists*.

To enter "*test mode*", you have to :

- Put in front the key switch in position "PROG".

Press "+" or "-" button until the display indicates "TEST".

Give a number from 1 to 7 to choose one of the below mentioned test functions.

To leave test mode : press the "STOP" button

## Test 1 : check the 8 inlets

Here it is indicated if the inlet contacts are opened (O) or closed (C).

To check the next inlet : press "ENTER".

To check the previous inlet : press "NO".

To stop this test, press "STOP".

I NP. THER. O : heat motor security

I NP. HEY . O : key switch

I NP. LOCH. O : doorlock S2

I NP. DOOR. O : doorlock S1

I NP. TI LT. C : tilt switch

I NP. SENS. C : sensor for rpm

I NP. TI HO. O : not applicable

I NP. BS . O : not applicable

### Example :

" T1. THER. O " : heat motor security open

" T1. THER. C " : heat motor security closed

## Test 2 : check the rpm

Step by step the basic speeds of the machine are executed.

Press "ENTER" each time to go to the next step.

PO00UO. 00

PO00UO. 00 the door is locked

LO( ( UO. 41 the drum turns left at wash speed. The target rpm are indicated on the right, whereas the control signal (XX) is indicated on the left.

PO00UO. 00 Pause

RO( ( UO. 41 the drum turns right at wash speed. The target rpm are indicated on the right, whereas the control signal (XX) is indicated on the left.

DO( ( UO. 84 the drum turns right at distribution speed. The target rpm are indicated on the right, whereas the control signal is indicated on the left.

LO( ( U5. 00 the drum turns right at low spin. The target rpm are indicated on the right, whereas the control signal (XX) is indicated on the left.

HO( ( U1. 00 the drum turns right at high spin. The target rpm are indicated on the right, whereas the control signal (XX) is indicated on the left.

## **Test 4 : Calibrate the water level sensor**

In this program, you can program the 0-level, maximum level and the number of divisions.

Wait to start the program until the water is out of the tub.

The display indicates "T4. LEV ( ( . ( ".

By pressing "0", the 0-level is calibrated.

Then press the "START" button.

Now the valve will be closed and water will be taken. The display shows the respective water level.

When the value does not longer increase on the display, this means that the highest level is achieved.

Press the "STOP" button now. Through this, the water inlet is stopped.

Then press "1". Through this, the highest level is calibrated.

Now program at "T4. LEV ( ( . ( " the number of divisions (maximum 99) and press "ENTER".

To stop the test , press the "STOP" button again.

## **Test 5 : check the temperature sensor**

The display shows " T5. ( ( . ( ". " XX.X " means the respective temperature in the tub.

To stop this test, press the "STOP" button.

## **Test 6 : check the 24 outlets.**

Here you can activate by turns the outlet contacts.

To check the next outlet, press "ENTER".

By pressing "0" or "1", the contact is opened or closed and the last display shows respectively "O" (open) or "C"

To check the previous outlet, press "NO".

To stop this test, press the "STOP" button.

OUT. DOOR. O: door lock  
OUT. HEAT. O: heating  
OUT. I RI . O: recycling inlet valve 1  
OUT. I 6 . O: inlet valve 6  
OUT. I 5 . O: inlet valve 5  
OUT. I 4 . O: inlet valve 4  
OUT. I 3 . O: inlet valve 3  
OUT. I 2 . O: inlet valve 2  
OUT. I 1 . O: inlet valve 1  
OUT. SO1 . O: soap pump 1  
OUT. S12 . O: soap pump 12  
OUT. DRA1. O: exhaust valve 1  
OUT. DRA2. O: exhaust valve 2

---

## Test 7 : keyboard

The display shows : “T8. - - ”

Each time you push a button now, the respective function is shown.

To stop this test, press the “STOP” button twice.

## Ram reset

Through this function, you can delete all data from the Ram memory.

Press o at “TEST”.

The display shows “*Code*”.

Enter “7 5 3 “ (quickly one after the other).



---

*By doing a ram reset, all self programmed program parts are deleted.*

---

## Connection of the liquid soap hoses

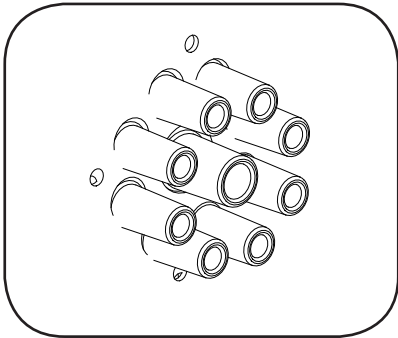

The liquid soap connection consists of **8 connections for liquid soap**.

The central opening is used for ventilation.

## Electrical connection of the liquid soap pumps

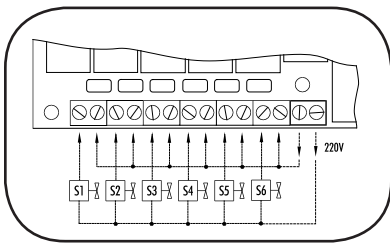

On machines equipped with a liquid soap connection, connect the wires **directly on the print board** next to the ground wire connection (option). Connect as indicated on the wiring diagram.

The two connectors on the right give a tension of 220V ~ (max. 4A) which can be applied to drive 220V ~ soap pumps. If more than **4A** is required, **an external tension** will have to be used. **6** connections have been provided, of which one (**S6**) can be used to drive a waterproofing pump (e.g. for rain coats, etc.).

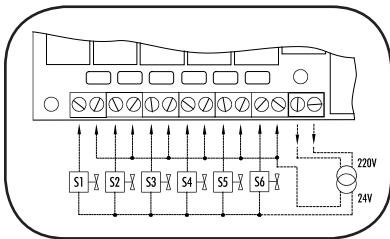

The 220V can be transformed to other values to drive other type soap pumps.

Example: pumps 24V ~.

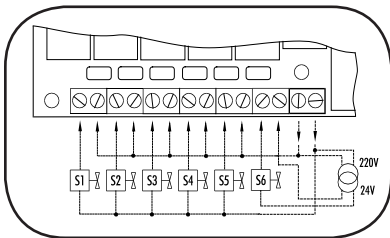

Also, pumps with different operating tension can be combined.

Example: 5 pumps 220V ~ and 1 pump 24V ~.

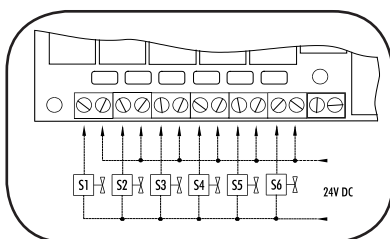

With an external tension 24V DC.

---

The table on the next page shows how the programmed data are registered.

## Standard programs

You can see on the next pages the composition of the standard programs.

Program 40:	Hot wash 1	40° - 90°
Program 41:	Warm wash	40° - 60°
Program 42 :	Synthetics 1	35° - 40°
Program 43 :	Synthetics 2	40°
Program 44 :	Gentle wash	30° - 30°
Program 45 :	Cold wash	20°
Program 46 :	Duvet	30° - 40°
Program 47 :	Curtains	30° - 40°
Program 48 :	Starch	
Program 49 :	Hot wash 2	40° - 90° (hot intermediate rinse)

For every type of machine a blank table is foreseen in which all the information of the own programs can be filled in. Copy the blank tables as many times as programs will be made. Fill them in and store them carefully.







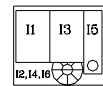

Segment	id	01	02	03	04	05	06	07	08		
Wash time	СУЭ , т	7	14	2	2	2					
	рoтE R	12	12	15	15	15					
	5	3	3	3	3	3					
	5P	41	41	41	41	41					
Temperature	тEнP °C	40	90	0	0	0					
Heating system	HEPт	/	/	/	/	/					
	HEPт - пoд	X	X	/	/	/					
	пoд	/	/	/	/	/					
Heating control	HECо т	3	7	/	/	/					
Wash action	GEнтLE	/	/	/	/	/					
Soft (tub)	SE - , т2	X	/	X	/	/					
Warm (tub)	т4	X	X	/	/	/					
Hard (kuip)	т6	/	/	/	X	X					
Soft (prewash)	т1	X	/	/	/	/					
Warm (main wash)	т3	/	X	/	/	/					
Hard (conditioner)	т5	/	/	/	/	X					
Recuperation 1	тr 1	/	/	/	/	/					
Soap injection	SoRP So т1										
	SoRP So т2										
	SoRP So т3										
	SoRP So т4										
	SoRP So т5										
	SoRP So т6										
	SoRP So т7										
	SoRP So т8										
	SoRP So т9										
	SoRP So т10										
	SoRP So т11										
	SoRP So т12										
Level	SE-L LE	13	10	20	20	16					
Level control	LECo LS	10	10	13	13	13					
Additional program	Add CooL пч										
	CooL п										
	Add CooL нч										
	CooL н										
	StoP т										
	SoRH т										
Spin	SP ин т	1	/	1	1	8					
	SP	500	/	500	500	1000					
Drain	d1 dt	X	30	X	X	X					
	d2 dt	/	/	/	/	/					
	d0	/	/	/	/	/					
	URSh	/	X	/	/	/					
	d,St	/	/	/	/	/					
	JoL т	/	X	/	/	/					
	drR ин	/	/	/	/	/					
Delay Time	dEt , тd	30	/	30	30	60					
	тz	8.30	14.30	3.30	3.30	11					
Tumble	ту					30					
Alarm	RLR-п т										

**Program : 41      Total time : 41' 30"      Name: Warm wash**

Segment	id	01	02	03	04	05	06	07	08		
Wash time	СУт , т	7	14	2	2	2					
	рoтE R	12	12	15	15	15					
	S	3	3	3	3	3					
	SP	41	41	41	41	41					
Temperature	тEнP °C	40	60	0	0	0					
Heating system	HEPт	/	/	/	/	/					
	HEPт - пoд	X	X	/	/	/					
	пoд	/	/	/	/	/					
Heating control	HECо т	3	7	/	/	/					
Wash action	СEнтLE	/	/	/	/	/					
Soft (tub)	SE- , и2	X	/	X	/	/					
Warm (tub)	и4	X	X	/	/	/					
Hard (kuip)	и6	/	/	/	X	X					
Soft (prewash)	и1	X	X	/	/	/					
Warm (main wash)	и3	/	X	/	/	/					
Hard (conditioner)	и5	/	/	/	/	X					
Recuperation 1	иr 1	/	/	/	/	/					
Soap injection	SoAP So т1										
	SoAP So т2										
	SoAP So т3										
	SoAP So т4										
	SoAP So т5										
	SoAP So т6										
	SoAP So т7										
	SoAP So т8										
	SoAP So т9										
	SoAP So т10										
	SoAP So т11										
	SoAP So т12										
Level	SE-L LE	13	10	20	20	16					
Level control	LECо LS	10	10	13	13	13					
Additional program	Rdd CоoL ч										
	CоoL ч										
	Rdd CоoL н										
	CоoL н										
	StoP т										
	SoRR т										
RLRRн т											
Spin	SP ин т	1	/	1	1	8					
	SP	500	/	500	500	1000					
Drain	d1 dt	X	30	X	X	X					
	d2 dt	/	/	/	/	/					
	d0	/	/	/	/	/					
	URSh	/	X	/	/	/					
	d ,5 т	/	/	/	/	/					
	JoL т	/	/	/	/	/					
	drR ин	/	/	/	/	/					
Delay Time	dEt , тd	30	/	30	30	60					
	тз	8.30	14.30	3.30	3.30	11					
Tumble	ту					30					
Alarm	RLRRн т										

**Program : 42 Total time : 27' 30" Name: Synthetics 1**

Segment	id	01	02	03	04	05	06	07	08		
Wash time	СУЭ, т	4	10	2	2	2					
	рoтE R	10	10	12	12	12					
	5	4	4	4	4	4					
	5P	41	41	41	41	41					
Temperature	тEнP °C	35	40	0	0	0					
Heating system	HEPт	/	/	/	/	/					
	HEPт-нoд	X	X	X	X	X					
	нoд	/	/	/	/	/					
Heating control	HECо т	2	4	/	/	/					
Wash action	ГEнтLE	/	/	/	/	/					
Soft (tub)	SE- , и2	X	X	X	/	/					
Warm (tub)	и4	X	X	/	/	/					
Hard (kuip)	и6	/	/	/	X	X					
Soft (prewash)	и1	X	/	/	/	/					
Warm (main wash)	и3	/	X	/	/	/					
Hard (conditioner)	и5	/	/	/	/	X					
Recuperation 1	иr 1	/	/	/	/	/					
Soap injection	SoRP So т 1										
	SoRP So т 2										
	SoRP So т 3										
	SoRP So т 4										
	SoRP So т 5										
	SoRP So т 6										
	SoRP So т 7										
	SoRP So т 8										
	SoRP So т 9										
	SoRP So т 10										
	SoRP So т 11										
	SoRP So т 12										
Level	SE-L LE	13	13	20	20	16					
Level control	LECо LS	10	10	13	13	13					
Additional program	Add CooL u4										
	CooL u										
	Add CooL n4										
	CooL n										
	StoP т										
	SoRH т										
Spin	SP иn т	/	/	/	/	4					
	SP	/	/	/	/	800					
Drain	d1 dt	30	30	30	30	X					
	d2 dt	/	/	/	/	/					
	d0	/	/	/	/	/					
	URSh	X	X	X	X	/					
	d,5т	/	/	/	/	/					
	JoL т	/	/	/	/	/					
	drR иn	/	/	/	/	2					
Delay Time	dEт, тd	/	/	/	/	60					
	т=	4.30	10.30	2.30	2.30	7					
Tumble	тu					30					
Alarm	RLR-и т										

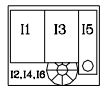

Segment	id	01	02	03	04	05	06	07	08		
Wash time	CEt , t	8	2	2	2						
	rotE R	10	10	10	10						
	S	5	5	5	5						
	SP	35	35	35	35						
Temperature	TE n P °C	35	0	0	0						
Heating system	HERt	/	/	/	/						
	HERt - mod	X	/	/	/						
	mod	/	/	/	/						
Heating control	HECo t	3	/	/	/						
Wash action	CE n t LE	/	/	/	/						
Soft (tub)	SE - , i2	X	X	/	/						
Warm (tub)	,4	X	/	/	/						
Hard (kuip)	,6	/	/	X	X						
Soft (prewash)	,1	X	/	/	/						
Warm (main wash)	,3	/	/	/	/						
Hard (conditioner)	,5	/	/	/	X						
Recuperation 1	rr 1	/	/	/	/						
Soap injection	SoAP So t 1										
	SoAP So t 2										
	SoAP So t 3										
	SoAP So t 4										
	SoAP So t 5										
	SoAP So t 6										
	SoAP So t 7										
	SoAP So t 8										
	SoAP So t 9										
	SoAP So t 10										
	SoAP So t 11										
	SoAP So t 12										
Level	SE -L LE	13	20	20	16						
Level control	LECo LS	10	13	13	13						
Additional program	Rdd Cool u										
	Cool u										
	Rdd Cool n										
	Cool n										
	StoP t										
	SoRR t										
	RLRr n t										
Spin	SP in t	/	/	/	3						
	SP	/	/	/	500						
Drain	d1 dt	30	30	30	X						
	d2 dt	/	/	/	/						
	d0	X	X	X	/						
	URSh	/	/	/	/						
	d ,5 t	/	/	/	/						
	Jolt t	/	/	/	/						
	drR in	/	/	/	/						
Delay Time	dEt , t d	/	/	/	30						
	t =	8.30	2.30	2.30	5.30						
Tumble	t u				30						
Alarm	RLRr n t										

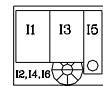

Segment	id	01	02	03	04	05	06	07	08		
Wash time	СУТ, т	4	7	2	2	2					
	рост R	3	3	5	5	5					
	S	10	10	10	10	10					
	SP	30	30	30	30	30					
Temperature	ТЕП °C	30	30	0	0	0					
Heating system	HEAT	/	/	/	/	/					
	HEAT-Mod	X	X	/	/	/					
	Mod	/	/	/	/	/					
Heating control	HEC t	2	3	/	/	/					
Wash action	ГЕНТЕ	/	/	/	/	/					
Soft (tub)	SE-1, 2	X	X	X	/	/					
Warm (tub)	14	/	/	/	/	/					
Hard (kuip)	16	/	/	/	X	X					
Soft (prewash)	11	X	/	/	/	/					
Warm (main wash)	13	/	X	/	/	/					
Hard (conditioner)	15	/	/	/	/	X					
Recuperation 1	1r 1	/	/	/	/	/					
Soap injection	SoRP So t 1										
	SoRP So t 2										
	SoRP So t 3										
	SoRP So t 4										
	SoRP So t 5										
	SoRP So t 6										
	SoRP So t 7										
	SoRP So t 8										
	SoRP So t 9										
	SoRP So t 10										
	SoRP So t 11										
	SoRP So t 12										
Level	SE-L LE	20	20	20	20	16					
Level control	LECO LS	13	13	13	13	13					
Additional program	Add Cool u										
	Cool u										
	Add Cool n										
	Cool n										
	Stop t										
	Soft t										
Spin	SP in t	/	/	/	/	2					
	SP	/	/	/	/	500					
Drain	d1 dt	30	30	30	30	X					
	d2 dt	/	/	/	/	/					
	d0	/	/	/	/	/					
	URSh	X	X	X	X	/					
	d, St	/	/	/	/	/					
	Jolt t	/	/	/	/	/					
	dr Rin	/	/	/	/	/					
Delay Time	dEt, td	/	/	/	/	30					
	t =	4.30	7.30	2.30	2.30	4.30					
Tumble	t u					30					
Alarm	ALAR t										

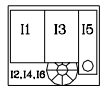

Segment	id	01	02	03	04	05	06	07	08		
Wash time	СУт , т	9	2	2	2						
	рoтE R	3	3	3	6						
	S	12	12	12	12						
	SP	25	25	25	25						
Temperature	тEнP °C	20	0	0	0						
Heating system	HEPт	/	/	/	/						
	HEPт - пoд	X	/	/	/						
	пoд	/	/	/	/						
Heating control	HECо т	3	/	/	/						
Wash action	СEнтLE	/	/	/	/						
Soft (tub)	SE - , ,2	X	X	/	/						
Warm (tub)	,4	/	/	/	/						
Hard (kuip)	,6	/	/	X	X						
Soft (prewash)	,1	X	/	/	/						
Warm (main wash)	,3	/	/	/	/						
Hard (conditioner)	,5	/	/	/	X						
Recuperation 1	р 1	/	/	/	/						
Soap injection	SoAP So т 1										
	SoAP So т 2										
	SoAP So т 3										
	SoAP So т 4										
	SoAP So т 5										
	SoAP So т 6										
	SoAP So т 7										
	SoAP So т 8										
	SoAP So т 9										
	SoAP So т 10										
	SoAP So т 11										
	SoAP So т 12										
Level	SE-L LE	18	18	18	16						
Level control	LECo LS	13	13	13	13						
Additional program	Rdd CooL y										
	CooL y										
	Rdd CooL n										
	CooL n										
	StoP т										
	SoRR т										
	RLRrП т										
Spin	SP ин т	/	/	/	1						
	SP	/	/	/	400						
Drain	d1 дт	30	30	30	X						
	d2 дт	/	/	/	/						
	d0	/	/	/	/						
	URSh	X	X	X	X						
	d ,5т	/	/	/	/						
	JoLт	/	/	/	/						
	drR ин	/	/	/	/						
Delay	dEt , тd	/	/	/	30						
Time	тз	9,30	2,30	2,30	3,30						
Tumble	ту				30						
Alarm	RLRrП т										

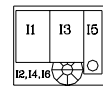

Segment	id	01	02	03	04	05	06	07	08		
Wash time	СУТ, т	6	6	2	2	2					
	рост R	5	5	5	5	5					
	S	10	10	10	10	10					
	SP	30	30	30	30	30					
Temperature	ТЕП °C	35	40	0	0	0					
Heating system	HEAT	/	/	/	/	/					
	HEAT-Mod	X	X	/	/	/					
	Mod	/	/	/	/	/					
Heating control	HEC t	2	2	/	/	/					
Wash action	ГЕНТЕ	/	/	/	/	/					
Soft (tub)	SE-1, 2	X	X	X	/	/					
Warm (tub)	14	X	/	/	/	/					
Hard (kuip)	16	/	/	/	X	X					
Soft (prewash)	11	X	/	/	/	/					
Warm (main wash)	13	/	X	/	/	/					
Hard (conditioner)	15	/	/	/	/	X					
Recuperation 1	17	/	/	/	/	/					
Soap injection	SoRP Sot 1										
	SoRP Sot 2										
	SoRP Sot 3										
	SoRP Sot 4										
	SoRP Sot 5										
	SoRP Sot 6										
	SoRP Sot 7										
	SoRP Sot 8										
	SoRP Sot 9										
	SoRP Sot 10										
	SoRP Sot 11										
	SoRP Sot 12										
Level	SE-L LE	20	20	20	20	20					
Level control	LECO LS	10	10	15	15	15					
Additional program	Add Cool up										
	Cool up										
	Add Cool dn										
	Cool dn										
	StoP t										
	SoRH t										
Spin	SP in t	/	/	/	/	1					
	SP	/	/	/	/	500					
Drain	d1 dt	30	30	30	30	X					
	d2 dt	/	/	/	/	/					
	d0	/	/	/	/	/					
	URSh	X	X	X	X	/					
	d, St	/	/	/	/	/					
	Jolt t	/	/	/	/	/					
	dr Rin	/	/	/	/	/					
Delay Time	dEt, td	/	/	/	/	/					
	t=	/	/	/	/	30					
Tumble	tu	6.30	6.30	2.30	2.30	3.30					
Alarm	ALAR t					30					





Segment	id	01	02	03	04	05	06	07	08		
Wash time	СУт , т	14	2	2	2	2					
	рoтE R	2	2	2	2	2					
	S	10	10	10	10	10					
	SP	25	25	25	25	25					
Temperature	тEнP °C	30	0	0	0	0					
Heating system	HEPт	/	/	/	/	/					
	HEPт - пoд	X	X	/	/	/					
	пoд	/	/	/	/	/					
Heating control	HECо т	7	/	/	/	/					
Wash action	СEнтLE	/	/	/	/	/					
Soft (tub)	SE - , ,2	X	X	/	/	/					
Warm (tub)	,4	/	/	/	/	/					
Hard (kuip)	,6	/	/	X	X	X					
Soft (prewash)	,1	X	/	/	/	/					
Warm (main wash)	,3	/	/	/	/	/					
Hard (conditioner)	,5	/	/	/	/	X					
Recuperation 1	р 1	/	/	/	/	/					
Soap injection	SoAP So т 1										
	SoAP So т 2										
	SoAP So т 3										
	SoAP So т 4										
	SoAP So т 5										
	SoAP So т 6										
	SoAP So т 7										
	SoAP So т 8										
	SoAP So т 9										
	SoAP So т 10										
	SoAP So т 11										
	SoAP So т 12										
Level	SE-L LE	20	20	20	20	20					
Level control	LECо LS	8	8	10	10	10					
Additional program	Rdd CоoL ч										
	CоoL ч										
	Rdd CоoL н										
	CоoL н										
	StoP т										
	SoRR т										
	RLRRн т										
Spin	SP ,н т	/	/	/	/	1					
	SP	/	/	/	/	350					
Drain	d1 dt	30	30	30	30	X					
	d2 dt	/	/	/	/	/					
	d0	/	/	/	/	/					
	URSh	X	X	X	X	/					
	d ,5 т	/	/	/	/	/					
	JoL т	/	/	/	/	/					
	drR ,н	/	/	/	/	/					
Delay Time	dEt , тd	/	/	/	/	30					
	тз	14.30	2.30	2.30	2.30	3.30					
Tumble	ту					30					
Alarm	RLRRн т										

Segment	id	01	02	03	04	05	06	07	08		
Wash time	СУт , т	3									
	рoтE R	15									
	5	2									
	5P	41									
Temperature	тEнP °C	0									
Heating system	HEPт	/									
	HEPт-нoд	/									
	нoд	/									
Heating control	HECо т	/									
Wash action	ГEнтLE	/									
Soft (tub)	SE- , и2	X									
Warm (tub)	и4	/									
Hard (kuip)	и6	/									
Soft (prewash)	и1	X									
Warm (main wash)	и3	/									
Hard (conditioner)	и5	/									
Recuperation 1	иr 1	/									
Soap injection	SoRP So т 1										
	SoRP So т 2										
	SoRP So т 3										
	SoRP So т 4										
	SoRP So т 5										
	SoRP So т 6										
	SoRP So т 7										
	SoRP So т 8										
	SoRP So т 9										
	SoRP So т 10										
	SoRP So т 11										
	SoRP So т 12										
Level	SE-L LE	9									
Level control	LECo LS	9									
Additional program	Add CooL u4										
	CooL u										
	Add CooL n4										
	CooL n										
	StoP т										
	SoRH т										
Spin	SP ин т	8									
	SP	1000									
Drain	d1 dt	X									
	d2 dt	/									
	d0	/									
	URSh	/									
	d,St	/									
	JoL т	/									
	drR ин	/									
Delay	dEt , тd	60									
Time	т=	12									
Tumble	ту	30									
Alarm	RLR-и т										

Program : 49 Total time : 44' Name: Hot wash 2

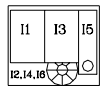

Segment	id	01	02	03	04	05	06	07	08		
Wash time	CEt , t	7	2	14	2	2	2				
	roEE R	12	10	12	15	15	15				
	S	3	4	3	3	3	3				
	SP	42	42	42	42	42	42				
Temperature	TE n P °C	40	90	90	0	0	0				
Heating system	HEAt	/	/	/	/	/	/				
	HEAt - mod	X	X	X	/	/	/				
	mod	/	/	/	/	/	/				
Heating control	HECo t	3	/	7	/	/	/				
Wash action	CE n t LE	/	/	/	/	/	/				
Soft (tub)	SE - , i2	X	/	/	X	/	/				
Warm (tub)	,4	X	X	X	/	/	/				
Hard (kuip)	,6	/	/	/	/	X	X				
Soft (prewash)	,1	X	/	/	/	/	/				
Warm (main wash)	,3	/	/	X	/	/	/				
Hard (conditioner)	,5	/	/	/	/	/	X				
Recuperation 1	rr 1	/	/	/	/	/	/				
Soap injection	SoAP So t 1										
	SoAP So t 2										
	SoAP So t 3										
	SoAP So t 4										
	SoAP So t 5										
	SoAP So t 6										
	SoAP So t 7										
	SoAP So t 8										
	SoAP So t 9										
	SoAP So t 10										
	SoAP So t 11										
	SoAP So t 12										
Level	SE - L LE	13	10	10	20	20	16				
Level control	LECo LS	10	10	10	13	13	13				
Additional program	Rdd Cool v										
	Cool v										
	Rdd Cool n										
	Cool n										
	StoP t										
	SoRR t										
	RLRr n t										
Spin	SP in t	1	/	/	1	1	8				
	SP	500	/	/	500	500	1000				
Drain	d1 dt	X	30	30	X	X	X				
	d2 dt	/	/	/	/	/	/				
	d0	/	X	X	/	/	/				
	URSh	/	/	/	/	/	/				
	d ,5 t	/	/	/	/	/	/				
	Jolt t	/	/	/	/	/	/				
	drR in	/	/	/	/	/	/				
Delay	dEt , t d	30	/	/	30	30	60				
Time	t =	8.30	2.30	14.30	3.30	3.30	11				
Tumble	t u										
Alarm	RLRr n t										





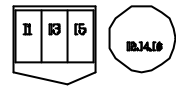

Segment	ID	01	02	03	04	05	06	07	08		
Wash time	CYTI T	7	14	2	2	2					
	ROTE A	12	12	15	15	15					
	S	3	3	3	3	3					
	SP	28	28	28	28	28					
Temperature	TEMP SC	40	90	0	0	0					
Heating system	HEAT	/	/	/	/	/					
	HEAT- MOD	X	X	/	/	/					
	MOD	/	/	/	/	/					
Heating control	HECO T	3	7	/	/	/					
Washaction	GENTLE	/	/	/	/	/					
Soft (tub)	SE- I I 2	X	/	X	/	/					
Warm (tub)	I 4	X	X	/	/	/					
Hard (kuip)	I 6	/	/	/	X	X					
Soft (prewash)	I 1	X	/	/	/	/					
Warm (main wash)	I 3	/	X	/	/	/					
Hard (conditioner)	I 5	/	/	/	/	X					
Recuperation 1	I R1	/	/	/	/	/					
Soapinjection	SOAP SO T1										
	SOAP SO T2										
	SOAP SO T3										
	SOAP SO T4										
	SOAP SO T5										
	SOAP SO T6										
	SOAP SO T7										
	SOAP SO T8										
	SOAP SO T9										
	SOAP SO T10										
	SOAP SO T11										
	SOAP SO T12										
Level	SE- L LE	20	20	25	25	20					
Level control	LECO LS	20	20	25	25	20					
Additional program	ADD COOL ' & COOL '										
	ADD COOL N& COOL N										
	STOP T										
	SOAK T										
	ALARM T										
Spin	SPI N T	1	/	1	1	8					
	SP	400	/	400	400	800 *					
Drain	D1 DT	X	30	X	X	X					
	D2 DT	/	/	/	/	/					
	DO	/	/	/	/	/					
	WASH	/	X	/	/	/					
	DI ST	/	/	/	/	/					
	JOLT	/	/	/	/	/					
	DRAI N	/	/	/	/	/					
Delay Time	DETI TD	60	/	60	60	60					
	T%	8.30	14.30	3.30	3.30	11					
Tumble	TU					30					
Alarm	ALARM T										

N.B: HF730 (\*) = SP 750

**Program : 41    Total time : 41' 30"    Name: Warm wash**

Segment	ID	01	02	03	04	05	06	07	08		
Wash time	CYTI T	7	14	2	2	2					
	ROTE A	12	12	15	15	15					
	S	3	3	3	3	3					
	SP	28	28	28	28	28					
Temperature	TEMP SC	40	60	0	0	0					
Heating system	HEAT	/	/	/	/	/					
	HEAT- MOD	X	X	/	/	/					
	MOD	/	/	/	/	/					
Heating control	HECO T	3	7	/	/	/					
Wash action	GENTLE	/	/	/	/	/					
Soft (tub)	SE- I I 2	X	/	X	/	/					
Warm (tub)	I 4	X	X	/	/	/					
Hard (tub)	I 6	/	/	/	X	X					
Soft (prewash)	I 1	X	X		/	/					
Warm (main wash)	I 3	/	X	/	/	/					
Hard (conditioner)	I 5	/	/	/	/	X					
Recuperation 1	I R1	/	/	/	/	/					
Soapinjection	SOAP SO T1										
	SOAP SO T2										
	SOAP SO T3										
	SOAP SO T4										
	SOAP SO T5										
	SOAP SO T6										
	SOAP SO T7										
	SOAP SO T8										
	SOAP SO T9										
	SOAP SO T10										
	SOAP SO T11										
	SOAP SO T12										
Level	SE- L LE	20	20	25	25	20					
Level control	LECO LS	20	20	25	25	20					
Additional program	ADD COOL ' & COOL '										
	ADD COOL N& COOL N										
	STOP T										
	SOAK T										
	ALARM T										
Spin	SPIN T	1	/	1	1	8					
	SP	400	/	400	400	800 *					
Drain	D1 DT	X	30	X	X	X					
	D2 DT	/	/	/	/	/					
	DO	/	/	/	/	/					
	WASH	/	X	/	/	/					
	DI ST	/	/	/	/	/					
	JOLT	/	/	/	/	/					
	DRAI N	/	/	/	/	/					
Delay	DETI TD	60	/	60	60	60					
	T%	8.30	14.30	3.30	3.30	11					
Tumble	TU					30					
Alarm	ALARM T										

N.B: HF730 (\*) = SP 750

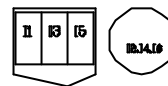

Segment	ID	01	02	03	04	05	06	07	08		
Wash time	CYTI T	4	10	2	2	2					
	ROTE A	10	10	12	12	12					
	S	4	4	4	4	4					
	SP	28	28	28	28	28					
Temperature	TEMP SC	35	40	0	0	0					
Heating system	HEAT	/	/	/	/	/					
	HEAT- MOD	X	X	X	X	X					
	MOD	/	/	/	/	/					
Heating control	HECO T	2	4	/	/	/					
Washaction	GENTLE	/	/	/	/	/					
Soft (tub)	SE- I I 2	X	X	X	/	/					
Warm (tub)	I 4	X	X	/	/	/					
Hard (kuip)	I 6	/	/	/	X	X					
Soft (prewash)	I 1	X	/	/	/	/					
Warm (main wash)	I 3	/	X	/	/	/					
Hard (conditioner)	I 5	/	/	/	/	X					
Recuperation I	I R1	/	/	/	/	/					
Soapinjection	SOAP SO T1										
	SOAP SO T2										
	SOAP SO T3										
	SOAP SO T4										
	SOAP SO T5										
	SOAP SO T6										
	SOAP SO T7										
	SOAP SO T8										
	SOAP SO T9										
	SOAP SO T10										
	SOAP SO T11										
	SOAP SO T12										
Level	SE- L LE	20	20	25	25	20					
Level control	LECO LS	20	20	25	25	20					
Additional program	ADD COOL ' & COOL '										
	ADD COOL N& COOL N										
	STOP T										
	SOAK T										
	ALARM T										
Spin	SPI N T	/	/	/	/	4					
	SP	/	/	/	/	70					
Drain	D1 DT	30	30	30	30	X					
	D2 DT	/	/	/	/	/					
	DO	/	/	/	/	/					
	WASH	X	X	X	X	/					
	DI ST	/	/	/	/	/					
	JOLT	/	/	/	/	/					
	DRAI N	/	/	/	/	2					
Delay Time	DETI TD	/	/	/	/	60					
	T%	4.30	10.30	2.30	2.30	7					
Tumble	TU					30					
Alarm	ALARM T										



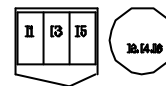

Program : 43 Total time : 19'30" Name: Synthetics 2

Segment	ID	01	02	03	04	05	06	07	08		
Wash time	CYTI T	8	2	2	2						
	ROTE A	10	10	10	10						
	S	5	5	5	5						
	SP	25	25	25	25						
Temperature	TEMP SC	35	0	0	0						
Heating system	HEAT	/	/	/	/						
	HEAT- MOD	X	/	/	/						
	MOD	/	/	/	/						
Heating control	HECO T	3	/	/	/						
Wash action	GENTLE	/	/	/	/						
Soft (tub)	SE- I I 2	X	X	/	/						
Warm (tub)	I 4	X	/	/	/						
Hard (tub)	I 6	/	/	X	X						
Soft (prewash)	I 1	X	/	/	/						
Warm (main wash)	I 3	/	/	/	/						
Hard (conditioner)	I 5	/	/	/	X						
Recuperation 1	I R1	/	/	/	/						
Soap injection	SOAP SO T1										
	SOAP SO T2										
	SOAP SO T3										
	SOAP SO T4										
	SOAP SO T5										
	SOAP SO T6										
	SOAP SO T7										
	SOAP SO T8										
	SOAP SO T9										
	SOAP SO T10										
	SOAP SO T11										
	SOAP SO T12										
Level	SE- L LE	20	25	25	20						
Level control	LECO LS	20	25	25	20						
Additional program	ADD COOL ' & COOL '										
	ADD COOL N & COOL N										
	STOP T										
	SOAK T										
	ALARM T										
Spin	SPI N T	/	/	/	3						
	SP	/	/	/	400						
Drain	D1 DT	30	30	30	X						
	D2 DT	/	/	/	/						
	DO	X	X	X	/						
	WASH	/	/	/	/						
	DI ST	/	/	/	/						
	JOLT	/	/	/	/						
	DRAI N	/	/	/	/						
Delay	DETI TD	/	/	/	60						
Time	T%	8.30	2.30	2.30	5.30						
Tumble	TU				30						
Alarm	ALARM T										

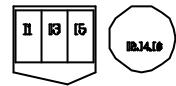

Segment	ID	01	02	03	04	05	06	07	08		
Wash time	CYTI T	4	7	2	2	2					
	ROTE A	3	3	5	5	5					
	S	10	10	10	10	10					
	SP	25	25	25	25	25					
Temperature	TEMP SC	30	30	0	0	0					
Heating system	HEAT	/	/	/	/	/					
	HEAT- MOD	X	X	/	/	/					
	MOD	/	/	/	/	/					
Heating control	HECO T	2	3	/	/	/					
Washaction	GENTLE	/	/	/	/	/					
Soft (tub)	SE- I I 2	X	X	X	/	/					
Warm (tub)	I 4	/	/	/	/	/					
Hard (kuip)	I 6	/	/	/	X	X					
Soft (prewash)	I 1	X	/	/	/	/					
Warm (main wash)	I 3	/	X	/	/	/					
Hard (conditioner)	I 5	/	/	/	/	X					
Recuperation I	I R1	/	/	/	/	/					
Soapinjection	SOAP SO T1										
	SOAP SO T2										
	SOAP SO T3										
	SOAP SO T4										
	SOAP SO T5										
	SOAP SO T6										
	SOAP SO T7										
	SOAP SO T8										
	SOAP SO T9										
	SOAP SO T10										
	SOAP SO T11										
	SOAP SO T12										
Level	SE- L LE	25	25	25	25	20					
Level control	LECO LS	25	25	25	25	20					
Additional program	ADD COOL ' & COOL '										
	ADD COOL N& COOL N										
	STOP T										
	SOAK T										
	ALARM T										
Spin	SPI N T	/	/	/	/	2					
	SP	/	/	/	/	40					
Drain	D1 DT	30	30	30	30	X					
	D2 DT	/	/	/	/	/					
	DO	/	/	/	/	/					
	WASH	X	X	X	X	/					
	DI ST	/	/	/	/	/					
	JOLT	/	/	/	/	/					
	DRAI N	/	/	/	/	/					
Delay Time	DETI TD	/	/	/	/	60					
	T%	4.30	7.30	2.30	2.30	4.30					
Tumble	TU					30					
Alarm	ALARM T										



Segment	ID	01	02	03	04	05	06	07	08		
Wash time	CYTI T	9	2	2	2						
	ROTE A	3	3	3	6						
	S	12	12	12	12						
	SP	22	22	22	22						
Temperature	TEMP SC	20	0	0	0						
Heating system	HEAT	/	/	/	/						
	HEAT- MOD	X	/	/	/						
	MOD	/	/	/	/						
Heating control	HECO T	3	/	/	/						
Wash action	GENTLE	/	/	/	/						
Soft (tub)	SE- I I 2	X	X	/	/						
Warm (tub)	I 4	/	/	/	/						
Hard (tub)	I 6	/	/	X	X						
Soft (prewash)	I 1	X	/	/	/						
Warm (main wash)	I 3	/	/	/	/						
Hard (conditioner)	I 5	/	/	/	X						
Recuperation 1	I R1	/	/	/	/						
Soapinjection	SOAP SO T1										
	SOAP SO T2										
	SOAP SO T3										
	SOAP SO T4										
	SOAP SO T5										
	SOAP SO T6										
	SOAP SO T7										
	SOAP SO T8										
	SOAP SO T9										
	SOAP SO T10										
	SOAP SO T11										
	SOAP SO T12										
Level	SE- L LE	25	25	25	20						
Level control	LECO LS	25	25	25	20						
Additional program	ADD COOL ' & COOL '										
	ADD COOL N& COOL N										
	STOP T										
	SOAK T										
	ALARM T										
Spin	SPI N T	/	/	/	1						
	SP	/	/	/	350						
Drain	D1 DT	30	30	30	X						
	D2 DT	/	/	/	/						
	DO	/	/	/	/						
	WASH	X	X	X	/						
	DI ST	/	/	/	/						
	JOLT	/	/	/	/						
	DRAI N	/	/	/	/						
Delay	DETI TD	/	/	/	60						
Time	T%	9.30	2.30	2.30	3.30						
Tumble	TU				30						
Alarm	ALARM T										

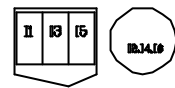

Segment	ID	01	02	03	04	05	06	07	08		
Wash time	CYTI T	6	6	2	2	2					
	ROTE A	5	5	5	5	5					
	S	10	10	10	10	10					
	SP	25	25	25	25	25					
Temperature	TEMP SC	35	40	0	0	0					
Heating system	HEAT	/	/	/	/	/					
	HEAT- MOD	X	X	/	/	/					
	MOD	/	/	/	/	/					
Heating control	HECO T	2	2	/	/	/					
Washaction	GENTLE	/	/	/	/	/					
Soft (tub)	SE- I I 2	X	X	X	/	/					
Warm (tub)	I 4	X	/	/	/	/					
Hard (kuip)	I 6	/	/	/	X	X					
Soft (prewash)	I 1	X	/	/	/	/					
Warm (main wash)	I 3	/	X	/	/	/					
Hard (conditioner)	I 5	/	/	/	/	X					
Recuperation I	I R1	/	/	/	/	/					
Soapinjection	SOAP SO T1										
	SOAP SO T2										
	SOAP SO T3										
	SOAP SO T4										
	SOAP SO T5										
	SOAP SO T6										
	SOAP SO T7										
	SOAP SO T8										
	SOAP SO T9										
	SOAP SO T10										
	SOAP SO T11										
	SOAP SO T12										
Level	SE- L LE	25	25	25	25	25					
Level control	LECO LS	25	25	25	25	25					
Additional program	ADD COOL ' & COOL '										
	ADD COOL N& COOL N										
	STOP T										
	SOAK T										
	ALARM T										
Spin	SPI N T	/	/	/	/	1					
	SP	/	/	/	/	40					
Drain	D1 DT	30	30	30	30	X					
	D2 DT	/	/	/	/	/					
	DO	/	/	/	/	/					
	WASH	X	X	X	X	/					
	DI ST	/	/	/	/	/					
	JOLT	/	/	/	/	/					
	DRAI N	/	/	/	/	/					
Delay Time	DETI TD	/	/	/	/	/					
	T%	/	/	/	/	60					
Tumble	TU	6.30	6.30	2.30	2.30	3.30					
Alam	ALARM T					30					



Segment	ID	01	02	03	04	05	06	07	08		
Wash time	CYTI T	14	2	2	2	2					
	ROTE A	2	2	2	2	2					
	S	10	10	10	10	10					
	SP	22	22	22	22	22					
Temperature	TEMP SC	30	0	0	0	0					
Heating system	HEAT	/	/	/	/	/					
	HEAT- MOD	X	X	/	/	/					
	MOD	/	/	/	/	/					
Heating control	HECO T	7	/	/	/	/					
Wash action	GENTLE	/	/	/	/	/					
Soft (tub)	SE- I I 2	X	X	/	/	/					
Warm (tub)	I 4	/	/	/	/	/					
Hard (tub)	I 6	/	/	X	X	X					
Soft (prewash)	I 1	X	/	/	/	/					
Warm (main wash)	I 3	/	/	/	/	/					
Hard (conditioner)	I 5	/	/	/	/	X					
Recuperation 1	I R1	/	/	/	/	/					
Soapinjection	SOAP SO T1										
	SOAP SO T2										
	SOAP SO T3										
	SOAP SO T4										
	SOAP SO T5										
	SOAP SO T6										
	SOAP SO T7										
	SOAP SO T8										
	SOAP SO T9										
	SOAP SO T10										
	SOAP SO T11										
	SOAP SO T12										
Level	SE- L LE	25	25	25	25	25					
Level control	LECO LS	25	25	25	25	25					
Additional program	ADD COOL ' & COOL '										
	ADD COOL N& COOL N										
	STOP T										
	SOAK T										
	ALARM T										
Spin	SPI N T	/	/	/	/	1					
	SP	/	/	/	/	30					
Drain	D1 DT	30	30	30	30	X					
	D2 DT	/	/	/	/	/					
	DO	/	/	/	/	/					
	WASH	X	X	X	X	/					
	DI ST	/	/	/	/	/					
	JOLT	/	/	/	/	/					
	DRAI N	/	/	/	/	/					
Delay	DETI TD	/	/	/	/	60					
Time	T%	14.30	2.30	2.30	2.30	3.30					
Tumble	TU					30					
Alarm	ALARM T										

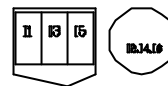

Segment	ID	01	02	03	04	05	06	07	08		
Wash time	CYTI T	3									
	ROTE A	15									
	S	2									
	SP	28									
Temperature	TEMP SC	0									
Heating system	HEAT	/									
	HEAT- MOD	/									
	MOD	/									
Heating control	HECO T	/									
Washaction	GENTLE	/									
Soft (tub)	SE- I I 2	X									
Warm (tub)	I 4	/									
Hard (kuip)	I 6	/									
Soft (prewash)	I 1	X									
Warm (main wash)	I 3	/									
Hard (conditioner)	I 5	/									
Recuperation I	I R1	/									
Soapinjection	SOAP SO T1										
	SOAP SO T2										
	SOAP SO T3										
	SOAP SO T4										
	SOAP SO T5										
	SOAP SO T6										
	SOAP SO T7										
	SOAP SO T8										
	SOAP SO T9										
	SOAP SO T10										
	SOAP SO T11										
	SOAP SO T12										
Level	SE- L LE	18									
Level control	LECO LS	18									
Additional program	ADD COOL ' & COOL '										
	ADD COOL N & COOL N										
	STOP T										
	SOAK T										
	ALARM T										
Spin	SPI N T	8									
	SP	800 *									
Drain	D1 DT	X									
	D2 DT	/									
	DO	/									
	WASH	/									
	DI ST	/									
	JOLT	/									
	DRAI N	/									
Delay	DETI TD	60									
Time	T%	12									
Tumble	TU	30									
Alarm	ALARM T										

N.B: HF730 (\*) = SP 750

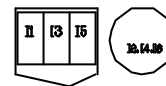

Segment	ID	01	02	03	04	05	06	07	08		
Wash time	CYTI T	7	2	14	2	2	2				
	ROTE A	12	10	12	15	15	15				
	S	3	4	3	3	3	3				
	SP	28	28	28	28	28	28				
Temperature	TEMP SC	40	90	90	0	0	0				
Heating system	HEAT	/	/	/	/	/	/				
	HEAT- MOD	X	X	X	/	/	/				
	MOD	/	/	/	/	/	/				
Heating control	HECO T	3	/	7	/	/	/				
Wash action	GENTLE	/	/	/	/	/	/				
Soft (tub)	SE- I I 2	X	/	/	X	/	/				
Warm (tub)	I 4	X	X	X	/	/	/				
Hard (tub)	I 6	/	/	/	/	X	X				
Soft (prewash)	I 1	X	/	/	/	/	/				
Warm (main wash)	I 3	/	/	X	/	/	/				
Hard (conditioner)	I 5	/	/	/	/	/	X				
Recuperation 1	I R1	/	/	/	/	/	/				
Soap injection	SOAP SO T1										
	SOAP SO T2										
	SOAP SO T3										
	SOAP SO T4										
	SOAP SO T5										
	SOAP SO T6										
	SOAP SO T7										
	SOAP SO T8										
	SOAP SO T9										
	SOAP SO T10										
	SOAP SO T11										
	SOAP SO T12										
Level	SE- L LE	22	20	20	25	25	20				
Level control	LECO LS	22	20	20	25	25	20				
Additional program	ADD COOL ' & COOL '										
	ADD COOL N & COOL N										
	STOP T										
	SOAK T										
	ALARM T										
Spin	SPIN T	1	/	/	1	1	8				
	SP	500	/	/	500	500	800 *				
Drain	D1 DT	X	30	30	X	X	X				
	D2 DT	/	/	/	/	/	/				
	DO	/	X	X	/	/	/				
	WASH	/	/	/	/	/	/				
	DI ST	/	/	/	/	/	/				
	JOLT	/	/	/	/	/	/				
	DRAI N	/	/	/	/	/	/				
Delay Time	DETI TD	60	/	/	60	60	60				
	T%	8.30	2.30	14.30	3.30	3.30	11				
Tumble	TU										
Alarm	ALARM T										

N.B: HF730 (\*) = SP 750





