

Washer-Extractor

Cabinet Hardmount
P-Series Microcomputer
Refer to page 2 for Model Identification

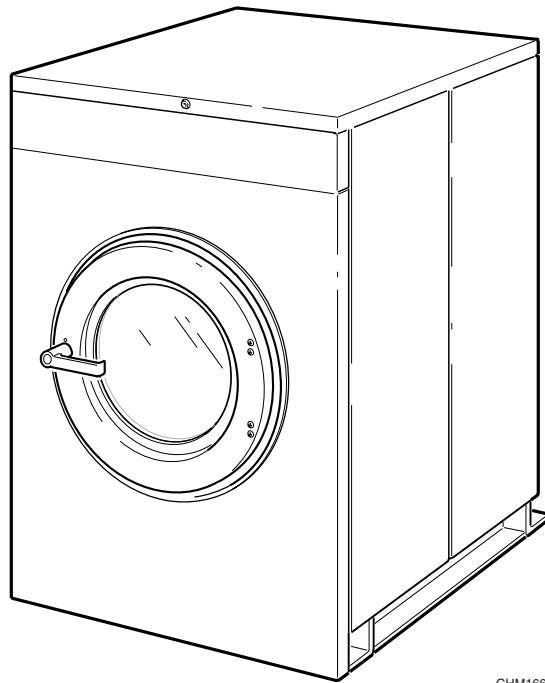

CHM166C

Keep These Instructions for Future Reference.

(If this machine changes ownership, this manual must accompany machine.)



www.comlaundry.com

Part No. F232064R3
May 2008

Programming

Table of Contents

Introduction	2
Model Identification	2
Nameplate Location.....	3
Replacement Parts	3
Customer Service.....	3
Safety Information	4
Explanation of Safety Messages	4
Important Safety Instructions	4
Safety Decals	6
Operator Safety	7
Programming	8
P-Series Microcomputers.....	8
Key Functions In Programming Mode	8
Setup Mode	8
Run Mode or Test Mode	8
Vend Price Enabled or Disabled.....	9
Coin Blocking Coil or Supply 3.....	9
1 or 4 Amounts to Start.....	9
Coin Value	9
Amount to Start.....	9
Cycle Programming	9
Entering Program Mode.....	10
Programming a Cycle	10
Supply Dispenser.....	12
Cycle Segment Charts.....	13
P-Computer Cycle Charts	16

© Copyright 2008, Alliance Laundry Systems LLC

All rights reserved. No part of the contents of this book may be reproduced or transmitted in any form or by any means without the expressed written consent of the publisher.

Introduction

Model Identification

Information in this manual is applicable to these models.

HC18PC2	UC18PC2
HC25PC2	UC25PC2
HC35PC2	UC35PC2
HC50PC2	UC50PC2
HC80PC2	UC80PC2

Nameplate Location

The nameplate is located at the rear of the machine and inside door. Always provide the machine's serial number and model number when ordering parts or when seeking technical assistance.

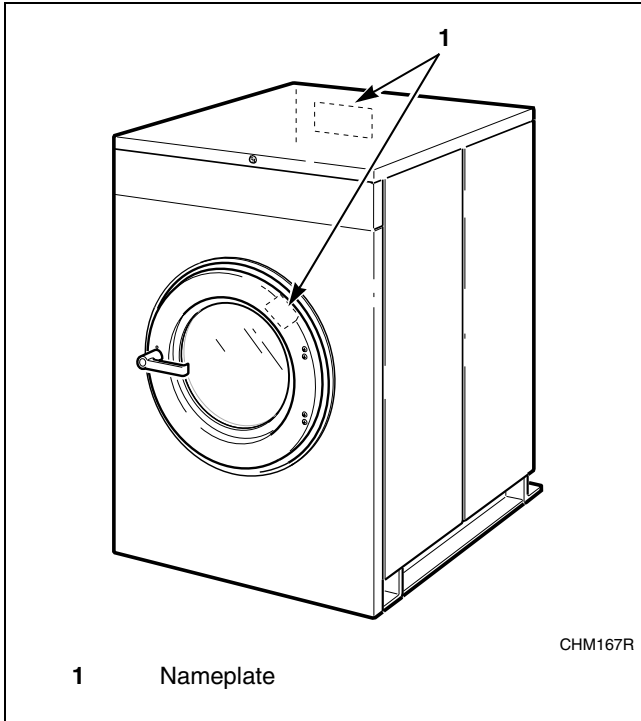

Replacement Parts

If literature or replacement parts are required, contact the source from whom the machine was purchased or contact Alliance Laundry Systems LLC at (920) 748-3950 for the name and address of the nearest authorized parts distributor.

Customer Service

For technical assistance, call the following number:

(920) 748-3121
Ripon, Wisconsin U.S.A.

Safety Information

Explanation of Safety Messages

Precautionary statements (“DANGER,” “WARNING,” and “CAUTION”), followed by specific instructions, are found in this manual and on machine decals. These precautions are intended for the personal safety of the operator, user, servicer, and those maintaining the machine.

	DANGER
DANGER indicates the presence of a hazard that will cause severe personal injury, death, or substantial property damage if the danger is ignored.	

	WARNING
WARNING indicates the presence of a hazard that can cause severe personal injury, death, or substantial property damage if the warning is ignored.	

	CAUTION
CAUTION indicates the presence of a hazard that will or can cause minor personal injury or property damage if the caution is ignored.	

Additional precautionary statements (“IMPORTANT” and “NOTE”) are followed by specific instructions.

IMPORTANT: The word “IMPORTANT” is used to inform the reader of specific procedures where minor machine damage will occur if the procedure is not followed.

NOTE: The word “NOTE” is used to communicate installation, operation, maintenance or servicing information that is important but not hazard related.

Important Safety Instructions

	WARNING
To reduce the risk of fire, electric shock, serious injury or death to persons when using your washer, follow these basic precautions:	
W023	

1. Read all instructions before using the washer.
2. Refer to the **GROUNDING INSTRUCTIONS** in the **INSTALLATION** manual for the proper grounding of the washer.
3. Do not wash textiles that have been previously cleaned in, washed in, soaked in, or spotted with gasoline, kerosene, waxes, cooking oils, dry-cleaning solvents, or other flammable or explosive substances as they give off vapors that could ignite or explode.
4. Do not add gasoline, dry-cleaning solvents, or other flammable or explosive substances to the wash water. These substances give off vapors that could ignite or explode.
5. Under certain conditions, hydrogen gas may be produced in a hot water system that has not been used for two weeks or more. **HYDROGEN GAS IS EXPLOSIVE.** If the hot water system has not been used for such a period, before using a washing machine or combination washer-dryer, turn on all hot water faucets and let the water flow from each for several minutes. This will release any accumulated hydrogen gas. The gas is flammable, do not smoke or use an open flame during this time.
6. Do not allow children to play on or in the washer. Close supervision of children is necessary when the washer is used near children. This is a safety rule for all appliances.
7. Before the washer is removed from service or discarded, remove the door to the washing compartment.
8. Do not reach into the washer if the wash drum is moving.

9. Do not install or store the washer where it will be exposed to water and/or weather.
10. Do not tamper with the controls.
11. Do not repair or replace any part of the washer, or attempt any servicing unless specifically recommended in the user-maintenance instructions or in published user-repair instructions that the user understands and has the skills to carry out.
12. To reduce the risk of an electric shock or fire, DO NOT use an extension cord or an adapter to connect the washer to the electrical power source.
13. Use washer only for its intended purpose, washing textiles.
14. Never wash machine parts or automotive parts in the machine. This could result in serious damage to the basket.
15. ALWAYS disconnect the washer from electrical supply before attempting any service. Disconnect the power cord by grasping the plug, not the cord.
16. Install the washer according to the INSTALLATION INSTRUCTIONS. All connections for water, drain, electrical power and grounding must comply with local codes and be made by licensed personnel when required.
17. To reduce the risk of fire, textiles which have traces of any flammable substances such as vegetable oil, cooking oil, machine oil, flammable chemicals, thinner, etc., or anything containing wax or chemicals such as in mops and cleaning cloths, must not be put into the washer. These flammable substances may cause the fabric to catch on fire by itself.
18. Do not use fabric softeners or products to eliminate static unless recommended by the manufacturer of the fabric softener or product.
19. Keep washer in good condition. Bumping or dropping the washer can damage safety features. If this occurs, have washer checked by a qualified service person.
20. If the supply cord is damaged, it must be replaced by a special cord or assembly available from the manufacturer or its service agent.
21. Be sure water connections have a shut-off valve and that fill hose connections are tight. CLOSE the shut-off valves at the end of each wash day.
22. Loading door MUST BE CLOSED any time the washer is to fill, tumble or spin. DO NOT bypass the loading door switch by permitting the washer to operate with the loading door open.
23. Always read and follow manufacturer's instructions on packages of laundry and cleaning aids. Heed all warnings or precautions. To reduce the risk of poisoning or chemical burns, keep them out of the reach of children at all times (preferably in a locked cabinet).
24. Always follow the fabric care instructions supplied by the textile manufacturer.
25. Never operate the washer with any guards and/or panels removed.
26. DO NOT operate the washer with missing or broken parts.
27. DO NOT bypass any safety devices.
28. Failure to install, maintain, and/or operate this washer according to the manufacturer's instructions may result in conditions which can produce bodily injury and/or property damage.

NOTE: The WARNINGS and IMPORTANT SAFETY INSTRUCTIONS appearing in this manual are not meant to cover all possible conditions and situations that may occur. Common sense, caution and care must be exercised when installing, maintaining, or operating the washer.

Any problems or conditions not understood should be reported to the dealer, distributor, service agent or the manufacturer.

	WARNING
<p>This machine must be installed, adjusted, and serviced by qualified electrical maintenance personnel familiar with the construction and operation of this type of machinery. They must also be familiar with the potential hazards involved. Failure to observe this warning may result in personal injury and/or equipment damage, and may void the warranty.</p>	
<small>SW004</small>	

IMPORTANT: Ensure that the recommended clearances for inspection and maintenance are provided. Never allow the inspection and maintenance space to be blocked.

	WARNING
<p>Install the machine on a level floor of sufficient strength. Failure to do so may result in conditions which can produce serious injury, death and/or property damage.</p>	
<small>W703</small>	

	CAUTION
<p>Be careful around the open door, particularly when loading from a level below the door. Impact with door edges can cause personal injury.</p>	
<small>SW025</small>	

	WARNING
<p>Never touch internal or external steam pipes, connections, or components. These surfaces can be extremely hot and will cause severe burns. The steam must be turned off and the pipe, connections, and components allowed to cool before the pipe can be touched.</p>	
<small>SW014</small>	

Safety Decals

Safety decals appear at crucial locations on the machine. Failure to maintain legible safety decals could result in injury to the operator or service technician.

To provide personal safety and keep the machine in proper working order, follow all maintenance and safety procedures presented in this manual. If questions regarding safety arise, contact the manufacturer immediately.

Use manufacturer-authorized spare parts to avoid safety hazards.

Operator Safety

	WARNING
<p>NEVER insert hands or objects into basket until it has completely stopped. Doing so could result in serious injury.</p> <p style="text-align: right;"><small>SW012</small></p>	

To ensure the safety of machine operators, the following maintenance checks must be performed daily:

1. Prior to operating the machine, verify that all warning signs are present and legible. Missing or illegible signs must be replaced immediately. Make certain that spares are available.
2. Check door interlock before starting operation of the machine:
 - a. Attempt to start the machine with the door open. The machine should not start with the door open.
 - b. Close the door without locking it and attempt to start the machine. The machine should not start with the door unlocked.
 - c. Close and lock the door and start a cycle. Attempt to open the door while the cycle is in progress. The door should not open.

If the door lock and interlock are not functioning properly, call a service technician.
3. Do not attempt to operate the machine if any of the following conditions are present:
 - a. The door does not remain securely locked during the entire cycle.
 - b. Excessively high water level is evident.
 - c. Machine is not connected to a properly grounded circuit.

Do not bypass any safety devices in the machine.

	WARNING
<p>Never operate the machine with a bypassed or disconnected balance system. Operating the machine with severe out-of-balance loads could result in personal injury and serious equipment damage.</p> <p style="text-align: right;"><small>SW039</small></p>	

Programming

P-Series Microcomputers

The computer board is inside the control module. Near the center of the board is a small toggle switch: this is the RUN/PROGRAM mode switch.

The switch is normally in the up (RUN mode) position. To enter PROGRAM mode, flip the switch to the down position. The display will now show “Pro.”

Since the keypad operates in a slightly different fashion when in PROGRAM mode, pay careful attention to the programming instructions provided in this manual.

Key Functions In Programming Mode

Hot—The Hot key is used to enter and exit cycle PROGRAM mode. The Hot key can also be used to exit SETUP mode.

Warm—The Warm key is used to scroll forward through program segment steps and setup options.

Cold/Normal—The Cold/Normal key is used to scroll forward from segment to segment, to increase numerical values such as step times, coin denomination, and vend prices, and to switch between available options.

Cold/Delicate—The Cold/Delicate key is used to enter SETUP mode. The Cold/Delicate key is also used to scroll backward from segment to segment, to decrease numerical values such as step times, coin denomination, and vend prices, and to switch between available options.

Setup Mode

Setup options are programmable options that are in effect for all wash formulas. These options include:

- RUN mode or TEST mode
- Vend price enabled or disabled
- Coin blocking coil or supply 3
- 1 or 4 amounts to start
- Coin value
- Amount to start

To enter SETUP mode, press the Cold/Delicate key while the display is showing “Pro.” Once in SETUP mode, use the Cold/Normal or Cold/Delicate key to change the selected option. Use the Warm key to accept the selected option and move on to the next one. Press the Hot key at any time to exit SETUP mode.

Run Mode or Test Mode

This setup option allows the machine to be placed in TEST mode for troubleshooting purposes. When in TEST mode, the computer allows one cycle to be run without having to meet the vend price. While that cycle is running, pressing the keypad keys will advance the cycle to the next cycle step. The computer returns to RUN mode upon completion of the test cycle.

If “tEST” is selected, the machine will be in TEST mode when the RUN/PROGRAM switch is placed in the RUN (up) position. If “norN” is selected, the machine will be in RUN mode when the RUN/PROGRAM switch is placed in the RUN (up) position.

Vend Price Enabled or Disabled

This setup option determines whether or not the vend price must be met before a cycle can be started. If “PAY” is selected, the vend price must be met. If “FrEE” is selected, no vend amount is necessary to start a cycle.

Coin Blocking Coil or Supply 3

This setup option determines whether the computer controls a coin blocking coil or allows a supply 3 to be programmed. If “CoiL” is selected, the computer will control a coin blocking coil. If “S3” is selected, supply 3 will be available for programming.

1 or 4 Amounts to Start

This setup option determines whether a single vend price will be used to start any cycle or a separate vend price will be used to start each cycle.

If “1AtS” is selected, a single vend price will be used for all four cycles. When in RUN mode, the display will flash “PAY” alternately with the vend price.

If “4AtS” is selected, each cycle will have a separate vend price. When in RUN mode, the display will scroll through the four cycles, alternately showing the respective vend price for each cycle.

Coin Value

This setup option establishes the value of the coin type accepted by the coin meter. Use the Cold/Normal and/or Cold/Delicate keys to set this value. If either of these keys is pressed and held, the displayed value changes more rapidly.

Amount to Start

This setup option sets the vend price (or prices) necessary to start a cycle. If “1AtS” was selected during setup, one value will be available for modification. If “4AtS” was selected during setup, the vend price for each cycle will be available for modification. Use the Cold/Normal and/or Cold/Delicate keys to set the vend price value(s). If either of these keys is pressed and held, the displayed value changes more rapidly.

Cycle Programming

To edit an existing cycle, press the Hot key while the display is showing “Pro.” The display will show “CY ?” Press the key which corresponds to the desired cycle (Hot, Warm, Cold/Normal and Cold/Delicate). The display will show “PrE.” The computer is now in cycle programming mode.

All 4 cycle programs can be customized within a preset program structure. Each cycle program consists of 6 program segments. See *Table 1*.

Cycle Program Segments			
Segment	Display	Segment	Display
Prewash	PrE	Rinse 2	rin2
Wash	UASH	Rinse 3	rin3
Rinse 1	rin1	Rinse 4	rin4

Table 1

When modifying a cycle, a time must be entered for each segment. To skip a segment or spin, set the time to “00.” Refer to *Table 2* for time parameters for each segment and spin.

Time Parameters		
Function	Minimum	Maximum
Prewash	60 seconds	1800 seconds
Wash	60 seconds	1800 seconds
Rinse 1	60 seconds	300 seconds
Rinse 2	60 seconds	300 seconds
Rinse 3	60 seconds	300 seconds
Rinse 4	60 seconds	300 seconds
Intermediate Spin	60 seconds	120 seconds
Final Spin	60 seconds	600 seconds

Table 2

Programming

Entering Program Mode

1. Unlock and raise top cover.
2. Remove control module cover.
3. Locate the Run/Program Mode switch near center of computer board inside control module. Refer to *Figure 1*.

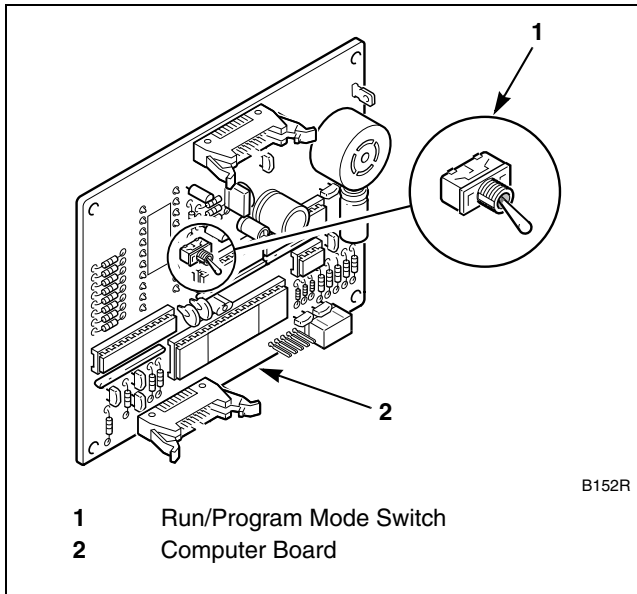

Figure 1

4. Flip switch to down position to enter PROGRAM Mode. Display will show "PrE".

Programming a Cycle

1. Select the cycle number to program: CY1, CY2, CY3 or CY4 by pressing Hot, Warm, Cold/Normal or Cold Delicate.
2. Press the Cold/Normal or Cold/Delicate key until the computer display shows the segment to be edited. The Cold/Normal key scrolls forward through the segments and the Cold/Delicate key scrolls backwards through the segments.

NOTE: The computer will exit cycle programming mode if one of the following happens:

- The Hot key is pressed.
- The Warm key is pressed when the final spin time is displayed.
- The Warm key is pressed when the time of "00" is displayed for "rin4."
- The Cold/Normal key is pressed when the display shows "rin4."
- The Cold/Delicate key is pressed when the display shows "PrE."

3. Once the desired segment is displayed, press the Warm key. The Warm key is used to step forward through the cycle segment steps.
4. Use the Cold/Normal or Cold/Delicate key to set the desired segment time. Set the value to "00" to skip the segment. Press the Warm key.

NOTE: The computer does not count down the remaining cycle time during fills or drains. The computer resumes counting down cycle time once the programmed fill level is reached and when the machine has drained.

5. Use the Cold/Normal or Cold/Delicate key to select the desired fill temperature. Refer to *Table 3*.

Fill Temperature Options	
Display	Fill Type
CFIL	Cold fill
HFIL	Hot fill
bFIL	Warm fill

Table 3

Refer to the *Cycle Segment Chart* section for detailed descriptions of cycles.

	WARNING
To avoid personal injury, recommended inlet water temperature should be no higher than 125° Fahrenheit (51° Celsius).	
<small>W709</small>	

6. Press the Warm key.
7. Use the Cold/Normal or Cold/Delicate key to select the desired fill level. Refer to *Table 4*.

Water Level Options	
Display	Fill Level
LOLE	Low Level
HILE	High Level
SLUC*	Overflow

*Machines shipped to France only.

Table 4

NOTE: “SLUC” is only available in the prewash segment. If “SLUC” is selected, the segment time will begin counting down once high level is reached. The fill valve(s) will remain on for the timed duration of the segment.

8. Press the Warm key.
9. For wash and rinse 1 segments only, use the Cold/Normal or Cold/Delicate key to enable or disable the bleach step. If “nobL” is selected, the bleach step is disabled. If “bL” is selected, the bleach step is enabled. Press the Warm key.
10. For prewash, wash, rinse 1, and rinse 4 segments only, use the Cold/Normal or Cold/Delicate key to enable or disable the supply step. If “nSUP” is selected, the supply step is disabled. If “SUP” is selected, the supply step is enabled. Press the Warm key.
11. If the supply step was enabled, use the Cold/Normal or Cold/Delicate key to select the desired supply option. Refer to *Table 5*.
12. Press the Warm key.
13. Use the Cold/Normal or Cold/Delicate key to select the desired spin time. Set this value to ”00” to skip the spin step. Press the Warm key. The display will now show the identifier for the next program segment.
14. Press the Hot key at any time to complete the cycle programming procedure.
15. Flip switch to up position to return to RUN mode.

Supply Options	
Display	Supply
SUP1	Supply 1
SUP2	Supply 2
SUP3*	Supply 3

* Supply 3 is available only if the “S3”/“CoiL” setup option is set to “S3.”

Table 5

Programming

Supply Dispenser

The supply dispenser compartments are designated 1, 2, and 3, in that order, viewed from the front of the machine, left to right.

Compartment 1 flushes with each fill. Compartment 2 flushes when the program calls for supply 2 during a fill. Compartment 3 flushes when the program calls for supply 3 during a fill.

If the program calls for a coin blocking coil instead of supply 3 during a fill, compartment 3 flushes with compartment 2.

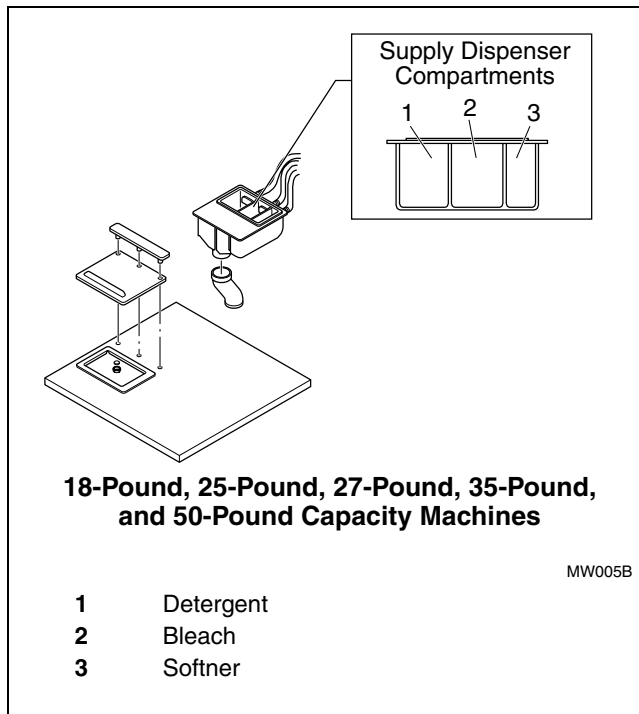

Figure 2

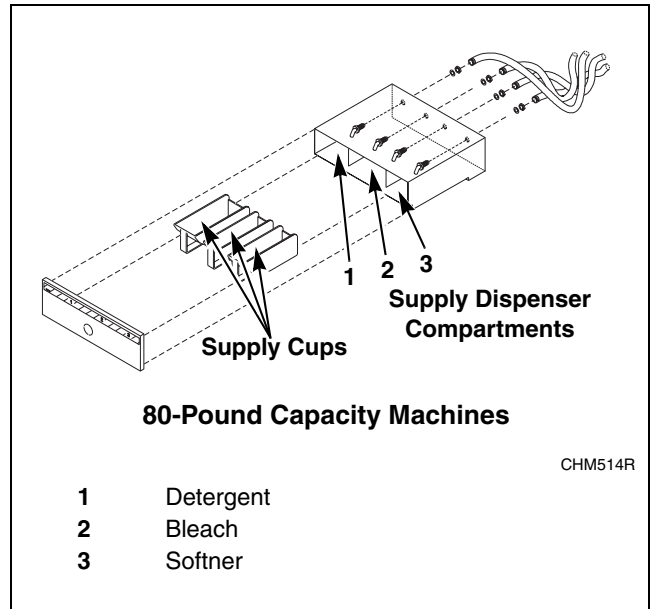

Figure 3

Cycle Segment Charts

Segment 1 (Prewash)	
Display	Instructions
	Use the Cold/Normal or Cold/Delicate key to change. Press the Warm key to advance.
PrE	
00 or 60 to 1800	Select segment time: 60 to 1800 seconds (00 to skip segment)
HFIL, CFIL, or bFIL	Select “HFIL” (hot fill), “CFIL” (cold fill), or “bFIL” (warm fill)
LOLE, HILE, or SLUC	Select fill level: “LOLE” (low water level), “HILE” (high water level), or “SLUC” (overflow fill)
nSUP or SUP	Select “nSup” (supply step disabled) or “SUP” (supply step enabled)
SUP1–SUP3*	Select supply 1–3
SPIn (flashed for one second)	
tINE (flashed for one second)	
00 or 60 to 120	Select time for spin: 60 to 120 seconds (00 for no spin)

* Available only if “SUP” is selected. “SUP3” is available only if the “S3”/“Coil” setup option is set to “S3.”

Table 6

Segment 2 (Wash)	
Display	Instructions
	Use the Cold/Normal or Cold/Delicate key to change. Press the Warm key to advance.
UASH	
00 or 60 to 1800	Select segment time: 60 to 1800 seconds (00 to skip segment)
HFIL, CFIL, or bFIL	Select “HFIL” (hot fill), “CFIL” (cold fill), or “bFIL” (warm fill)
LOLE or HILE	Select fill level: “LOLE” (low) or “HILE” (high) water level
nobL or bL	Select “nobL” (supply step disabled) or “bL” (supply step enabled)
nSUP or SUP	Select “nSup” (supply step disabled) or “SUP” (supply step enabled)
SUP1–SUP3*	Select supply 1–3
SPIn (flashed for one second)	
tINE (flashed for one second)	
00 or 60 to 120	Select time for spin: 60 to 120 seconds (00 for no spin)

* Available only if “SUP” is selected. “SUP3” is available only if the “S3”/“Coil” setup option is set to “S3.”

Table 7

Cycle Segment Charts (continued)

Programming

Cycle Segment Charts (continued)

Segment 3 (Rinse 1)	
Display	Instructions
	Use the Cold/Normal or Cold/Delicate key to change. Press the Warm key to advance.
rin1	
00 or 60 to 300	Select segment time: 60 to 300 seconds (00 to skip segment)
HFIL, CFIL, or bFIL	Select “HFIL” (hot fill), “CFIL” (cold fill), or “bFIL” (warm fill)
LOLE or HILE	Select fill level: “LOLE” (low) or “HILE” (high) water level
nobL or bL	Select “nobL” (supply step disabled) or “bL” (supply step enabled)
nSUP or SUP	Select “nSup” (supply step disabled) or “SUP” (supply step enabled)
SUP1–SUP3*	Select supply 1–3
SPIn (flashed for one second)	
tINE (flashed for one second)	
00 or 60 to 120	Select time for spin: 60 to 120 seconds (00 for no spin)

* Available only if “SUP” is selected. “SUP3” is available only if the “S3”/“CoIL” setup option is set to “S3.”

Table 8

Segments 4 and 5 (Rinses 2 and 3)	
Display	Instructions
	Use the Cold/Normal or Cold/Delicate key to change. Press the Warm key to advance.
rin2 or rin3	
00 or 60 to 300	Select segment time: 60 to 300 seconds (00 to skip segment)
HFIL, CFIL, or bFIL	Select “HFIL” (hot fill), “CFIL” (cold fill), or “bFIL” (warm fill)
LOLE or HILE	Select fill level: “LOLE” (low), or “HILE” (high) water level
SPIn (flashed for one second)	
tINE (flashed for one second)	
00 or 60 to 120	Select time for spin: 60 to 120 seconds (00 for no spin)

Table 9

Cycle Segment Charts (continued)

Cycle Segment Charts (continued)

Segment 6 (Rinse 4)	
Display	Instructions
	Use the Cold/Normal or Cold/Delicate key to change. Press the Warm key to advance.
rin4	
00 or 60 to 300	Select segment time: 60 to 300 seconds (00 to skip segment)
HFIL, CFIL, or bFIL	Select “HFIL” (hot fill), “CFIL” (cold fill), or “bFIL” (warm fill)
LOLE or HILE	Select fill level: “LOLE” (low), or “HILE” (high) water level
nSUP or SUP	Select “nSup” (supply step disabled) or “SUP” (supply step enabled)
SUP1–SUP3*	Select supply 1–3
SPIn (flashed for one second)	
tINE (flashed for one second)	
00 or 60 to 600	Select time for spin: 60 to 600 seconds (00 for no spin)

* Available only if “SUP” is selected. “SUP3” is available only if the “S3”/“CoiL” setup option is set to “S3.”

Table 10

P-Computer Cycle Charts

P-Computer Standard Cycles					
Program		Hot	Warm	Cold/Normal	Cold/Delicate
Prewash	Time (Sec)	120	120	120	00
	Water	Warm	Warm	Cold	---
	Level	High	High	High	---
	Supply	No	No	No	---
	Spin (Sec)	60	60	60	---
Wash	Time (Sec)	240	240	240	240
	Water	Hot	Warm	Cold	Cold
	Level	Low	Low	Low	Low
	Bleach	Yes	Yes	Yes	No
	Supply	1	1	1	1
	Spin (Sec)	60	60	60	60
Rinse 1	Time (Sec)	90	90	90	90
	Water	Cold	Cold	Cold	Cold
	Level	High	High	High	High
	Bleach	No	No	No	No
	Supply	No	No	No	No
	Spin (Sec)	60	60	60	60
Rinse 2	Time (Sec)	90	90	90	90
	Water	Cold	Cold	Cold	Cold
	Level	High	High	High	High
	Spin (Sec)	60	60	60	60
Rinse 3	Time (Sec)	00	00	00	00
	Water	---	---	---	---
	Level	---	---	---	---
	Spin (Sec)	---	---	---	---
Rinse 4	Time (Sec)	90	90	90	90
	Water	Cold	Cold	Cold	Cold
	Level	High	High	High	High
	Supply	2	2	2	2
	Spin (Sec)	240	240	240	120

Table 11

P-Computer cycle charts (continued)

Cycle:					
Prewash		Wash		Rinse 1	
Time (Sec)		Time (Sec)		Time (Sec)	
Water		Water		Water	
Level		Level		Level	
Supply		Bleach		Bleach	
Drain		Supply		Supply	
Spin (Sec)		Drain		Drain	
		Spin (Sec)		Spin (Sec)	
Rinse 2		Rinse 3		Rinse 4	
Time (Sec)		Time (Sec)		Time (Sec)	
Water		Water		Water	
Level		Level		Level	
Spin (Sec)		Spin (Sec)		Supply	
				Spin (Sec)	

Table 12