

180 SECONDS PER STEP

MACHINE FUNCTION

SUPER WASH	FILL & WASH
HEAVY	FILL & WASH
	DRY AGITATE - LOW
	DRAIN HI
	SPIN HIGH
	FILL & RINSE
	DRAIN HI
	SPIN HI
PERMANENT PRESS	OFF
	FILL & WASH
	COOL DOWN
	DRAIN HI
	SPIN LOW
	FILL & RINSE
	DRAIN HI
	SPIN LOW
DELICATE	OFF
	FILL & WASH
	DRAIN HI
	SPIN LOW
	FILL & RINSE
	DRAIN HI
	SPIN LOW
HAND WASHABLES	OFF
	FILL & WASH
	DRAIN HI
	SPIN LOW
	FILL & RINSE
	DRAIN HI
	SPIN LOW

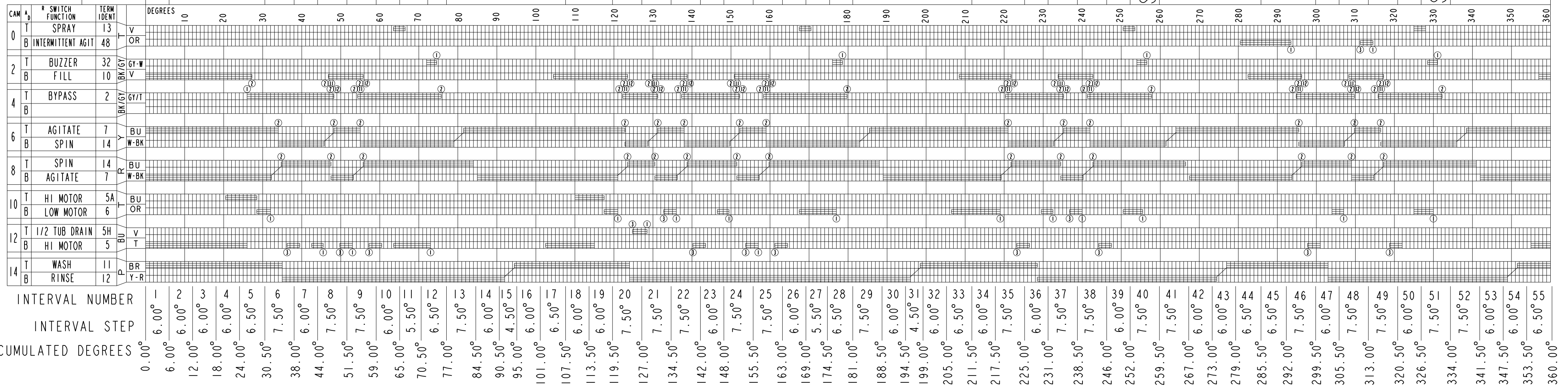

LEGEND	LEGENDE	LEYENDA	LEGEND	LEGENDE	LEYENDA
1/2 TUB DRAIN	1/2 COVETTE VID	DREN DE LA TINA DEL 1/2	SWITCH FUNCTION	COMMUTEZ LA FONCTION	CAMBIE LA FUNCTION
SPRAY	GICLAGE	AEROSOL	CAM	CAME	LEVA
BYPASS	DERIVATION	PUENTE	OFF	ARRET	DE
FILL	REMPLISSAGE	LLENAN	COOL DOWN	REFROIDISSEZ	REFRESQ'UESE ABAJO
AGITATE	AGITER	AGITAN	SPIN LOW	ROTATION BASSE	VUELTA BAJA
SPIN	ESSORAGE	VUELTA	INTERMITTENT AGITATION	AGITATION INTERMITTENTE	AGITACION INTERMITENTE
HI MOTOR	MOTEUR RAPIDE	ALTO MOTOR	TIMER SWITCH	COMMUTEUR TEMPORISATEUR	INTERRUPTOR CONTADOR TIEMPO
LOW MOTOR	MOTEUR BAS	BAJO MOTOR	SUB-INTERVAL PATTERN	MODELE D'SOUS-INTERVALLE	PATRON DEL SUB-INTERVAL
BUZZER	VIBREUR	ZUMBADOR	SPIN HI	ROTATION HAUTE	VUELTA ALTA
WASH	LAVAGE	COLADA	MACHINE FUNCTION	FUNTION DE MACHINE	FUNCON DE LA MAQUINA
RINSE	RINCAGE	ACLARACION	EXTRA RINSE	SUPPLEMENTAIRE RINCAGE	ADICIONAL ACLARACION
DRAIN	VIDENT	DRENAN	SECONDS	SECONDES	SEQUONDOS
SUPER WASH	LAVAGE SUPERBE	COLADA ESTUPENDDA	TERMINAL IDENTIFIER	TERMINAL IDENTIFICATEUR	TREMINAL IDENTIFICADOR
HAND WASHABLES	WASHABLES DE MAIN	WASHABLES DE LA MANO	STEP	ETAPE	PASO DE PROGRESION
ACCUMULATED DEGREES	DEGRES ACCUMULES	GRADOS ACUMULADOS			
DELICATE	SENSIBLE	DELICADO			
PERMANENT PRESS	SYNTHETIQUES	PERMANENTE PRENSA			
INTERVAL NUMBER	NOMBRES D'INTERVALLE	NUMEROS DEL INTERVALO			
HEAVY	LOURD	PESADO			

CAM 0
 TIMER SWITCH #13 (SPRAY)
 TIMER SWITCH #48 (INTERMITTENT AGIT)
 SUB-INTERVAL PATTERN

PART NO. NUMERO DE PIECE NUMERO DE PIEZA	REV REVISION REVISION
3954577	A

LEGEND / LEGENDE / LEYENDA

- 0 — TIMER SWITCH
INT. DU PROGRAMMATEUR
INTERRUPTOR DEL TEMPORIZADOR
- INT. COMP CONNECTION
CONNEXION INTERNE DE COMPOSANT
CONEXION INTERNO DEL COMPONENTE
- HARNESS WIRING
FAISCEAU DE FILS
CABLEADO DEL HARNESS
- — HARNESS CONNECTION
CONNEXION DE FILS
CONEXION DEL HARNESS
- — TERMINAL CONNECTION
CONEXION DE LA BORNE
TERMINAL CONEXION
- WASH RINSE / RINCAGE DE LAVAGE
/ ACLARACION DE LA COLADA
- DRIVE MOTOR / MOTEUR / IMPULSOR MOTOR
- L LOW / LENT / BAJO
M MEDIUM / SUPPORT / MEDIA
H HIGH / HAUT / ALTO
S START / DEMARRENT / EMPIEZAN
- H — HOT VALVE
SQUAPE D'EAU CHAUDE
CALIENTE VALVULA
- C — COLD VALVE
SQUAPE D'EAU FROIDE
FRIA VALVULA
- ATC SENSOR / CAPTEUR D'ATC / SENSOR DEL ATC
- ATC BOARD / PANNEAU D'ATC / TARJETA DEL ATC

- WATER LEVEL SWITCH
INTERRUPTEUR NIVEAU D'EAU
INTERRUPTOR DEL NIVEL DEL AGUA
- — FULL / PLEIN / POR COMPLETO
- — EMPTY / VIDE / VACIO
- LID SWITCH
INTERRUPTEUR DU COUVERCLE
INTERRUPTOR DE LA TAPA
- TIMER MOTOR
MOTEUR DE LA MINUTERIE
MOTOR DEL TEMPORIZADOR
- CENTRIFUGAL SWITCH
CONTACTEUR CENTRIFUGE
CENTRIFUGO INTERRUPTOR
- CABINET GROUND
TERRE DU CHASSI
CABIN MOLIDA
- CAPACITOR / CONDENSATEUR /
CONDENSADOR (661606)
- FUSE / FUSIBLE / FUSIBLE
- B — BUZZER / VIBREUR / SENAL SONORA
- BLEACH DISPENSE CIRCUIT NOT USED ALL MODELS
L'AGENT DE BLANCHIMENT DISTRIBUENT LE CIRCUIT
NON UTILISE TOUS LES MODELS
EL BLANQUEO DISPENSA EL CIRCUITO NO USADO
TODOS LOS MODELOS
- TSC TEMPERATURE SWITCH CHART
DIAGRAMME DE COMMUTATEUR DE LA TEMPERATURE
CARTA DE INTERRUPTOR DE LA TEMPERATURA

TIMER KNOB PUSH OFF
ALL TIMER SWITCHES OPEN
TIRE POUR MARCHE POUSSE POUR ARRETE
BOUTON-FOUSSOIR DU PROGRAMMATEUR
LOS INTERRUPTORES SE ABREN
CUANDO LA PERILLA EMPUJO DE

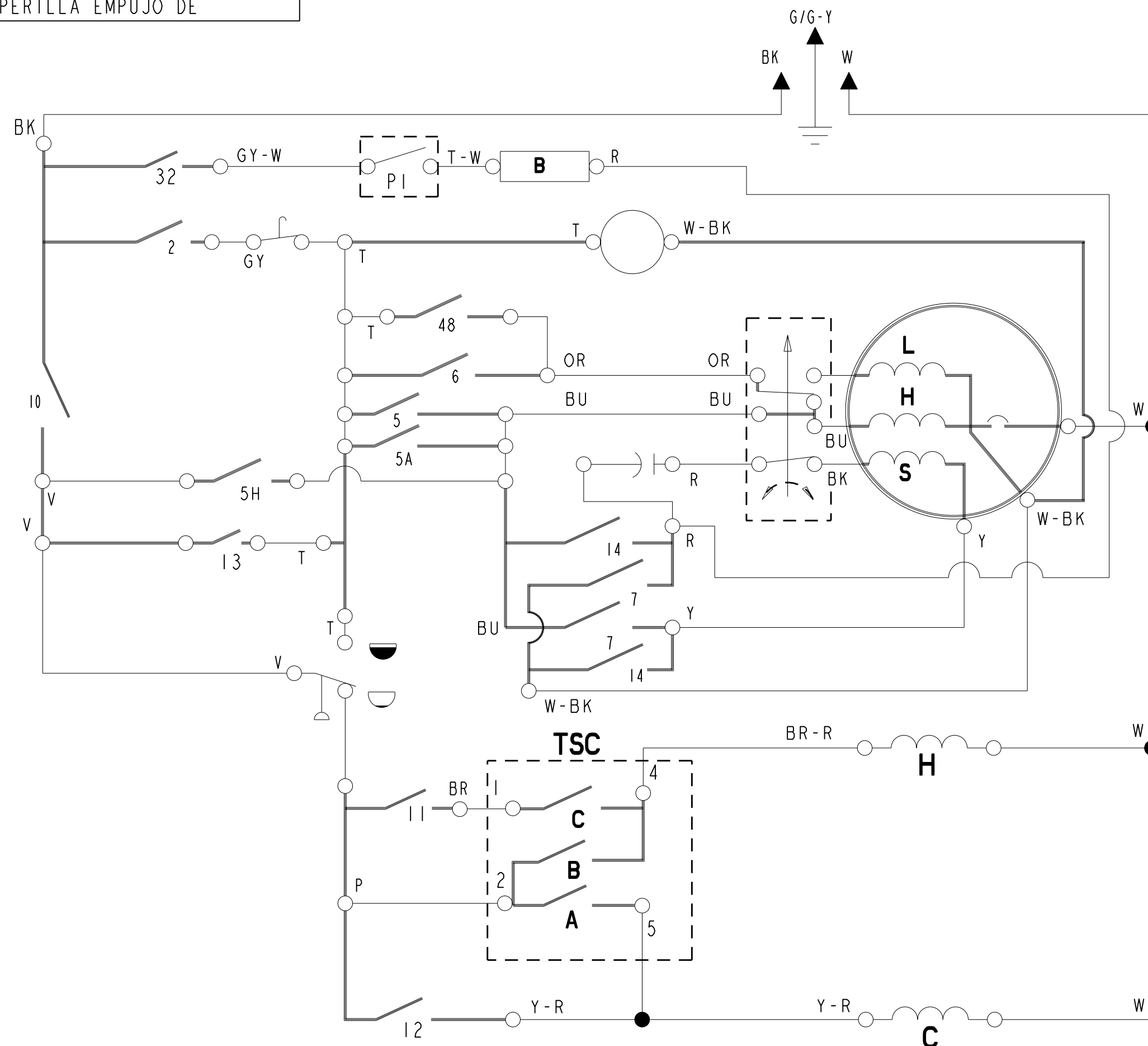

CE PRODUIT EST COUVERT PAR
UN DU PLUS DES BREVENTS
CANADIENS SUIVANTS:
1. 022.764 1. 128.597 1. 244.255
1. 115.977 1. 131.928 1. 264.080
1. 117.778 1. 160.855 1. 274.701
1. 121.789 1. 199.201 1. 287.338
1. 126.536 1. 199.202 1. 290.161
1. 128.596 1. 237.291 1. 298.988

MANUFACTURED UNDER ONE OR
MORE OF THE FOLLOWING
UNITED STATES PATENTS:
DES. 268,183 3,854,308 4,003,613 4,262,870
3,576,117 3,856,036 4,005,882 4,268,098
3,636,734 3,863,467 4,068,503 4,288,671
3,681,947 3,880,188 4,118,957 4,291,556
3,696,970 3,884,493 4,129,018 4,306,841
3,744,418 3,939,674 4,163,457 4,324,035
3,798,931 3,953,146 4,164,130 4,357,813
3,798,932 3,987,508 4,174,622 4,366,902
3,818,729 3,987,651 4,254,640 4,430,871
3,847,812 4,000,631 4,254,641 4,432,528

END OF CYCLE SIGNAL EXTREME DE SIGNAL DE CYCLE EXTREMO DE LA SENAL SENAL DEL CICLO	PI
OFF ARRET DE	
ON SUR DE	X

TSC				
SWITCH COMMUTANT CAMBIAN	HC	WC	CC	# WW
A		X	X	X
B				X
C	X	X		X

NOT USED ALL MODELS
NON UTILISE TOUS LES MODELES
NO UTILIZADO TODOS LOS MODELOS