

PART NO	REV
8530145	C

DRIVE MOTOR	
MOTOR WINDING	RESISTANCE AT MOTOR
RD TO WH	3.1 Ohms
YL TO WH	2.8 Ohms
RD TO YL	5.9 Ohms

PUMP MOTOR	
MOTOR WINDING	RESISTANCE AT MOTOR
RD TO WH	11.1 Ohms
YL TO WH	11.1 Ohms
RD TO YL	22.2 Ohms

THERMISTOR RESISTOR CHART	
TEMPERATURE DEGREES (F)	RESISTANCE (OHMS)
40	126k - 135k
50	97k - 102k
60	75k - 78k
70	58k - 61k
80	46k - 47k
90	36k - 37k
100	28k - 30k
110	23k - 24k
120	18k - 19k
130	15k - 16k
140	12k - 13k
150	10k - 11k

- PART NO & ELECT COMPONENTS KEY:
- 8299604 KEYSWITCH BISCUIT
 - 8318468 KEYSWITCH SILVER
 - 8054766 OPERATING PRESSURE SWITCH
 - 8529923 HARNESS - UPPER
 - 8299814 HARNESS - LOWER
 - 8318209 POWER CORD
 - 8272124 SWITCH - LID
 - 8542693 UNIV MACH CTL - ASM
 - 8541034 MOTOR CONTROLLER & MOUNT ASM
 - 8300022 INTERLOCK SWITCH
 - 9724754 LOG VALVE
 - 8055146 LINE FILTER
 - (8528338 LINE FILTER ALT.)

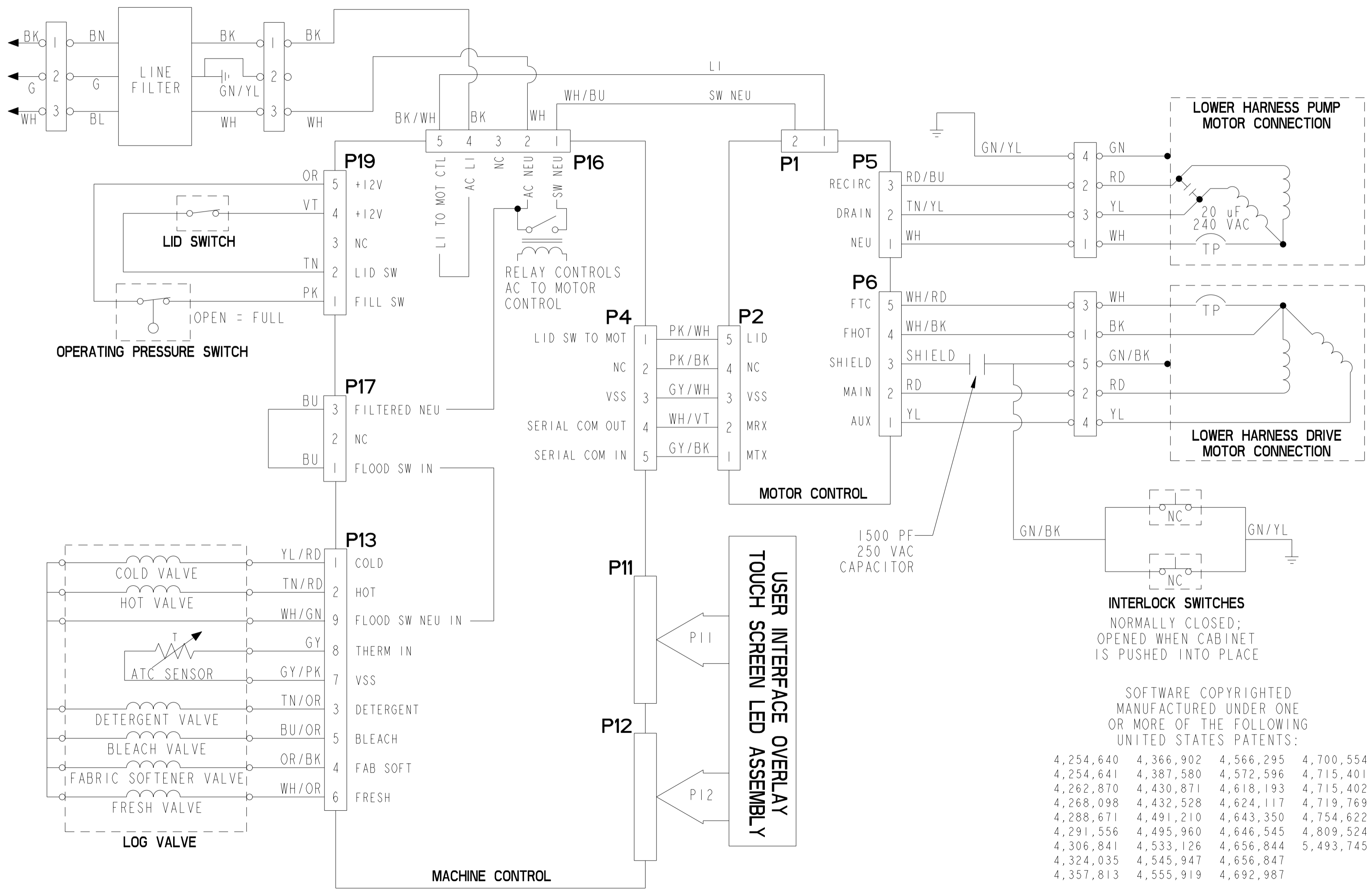

INTERLOCK SWITCHES
 NORMALLY CLOSED;
 OPENED WHEN CABINET
 IS PUSHED INTO PLACE

SOFTWARE COPYRIGHTED
 MANUFACTURED UNDER ONE
 OR MORE OF THE FOLLOWING
 UNITED STATES PATENTS:

4,254,640	4,366,902	4,566,295	4,700,554
4,254,641	4,387,580	4,572,596	4,715,401
4,262,870	4,430,871	4,618,193	4,715,402
4,268,098	4,432,528	4,624,117	4,719,769
4,288,671	4,491,210	4,643,350	4,754,622
4,291,556	4,495,960	4,646,545	4,809,524
4,306,841	4,533,126	4,656,844	5,493,745
4,324,035	4,545,947	4,656,847	
4,357,813	4,555,919	4,692,987	

NUMERO DE PIECE	REV
8530145	C

MOTEUR PRINCIPAL	
BOBINAGE	RESISTANCE SUR LE MOTEUR
RD TO WH	3.1 Ohms
YL TO WH	2.8 Ohms
RD TO YL	5.9 Ohms

MOTEUR DE LA POMPE	
BOBINAGE	RESISTANCE SUR LE MOTEUR
RD TO WH	11.1 Ohms
YL TO WH	11.1 Ohms
RD TO YL	22.2 Ohms

TABLEAU DES THERMISTANCES	
TEMPERATURE (DEGRES (F))	RESISTANCE (OHMS)
40	126k - 135k
50	97k - 102k
60	75k - 78k
70	58k - 61k
80	46k - 47k
90	36k - 37k
100	28k - 30k
110	23k - 24k
120	18k - 19k
130	15k - 16k
140	12k - 13k
150	10k - 11k

- N° DE PIECE ET REPERAGE DES COMPOSANTS:
- 8299604 CLE' INTERRUPTEUR BISCUIT
 - 8318468 CLE' INTERRUPTEUR ARGENT
 - 8054766 MANOCONTACTEUR (MACHINE EN SERVICE)
 - 8529923 CABLAGE - SUPERIEUR
 - 8299814 CABLAGE - INFÉRIEUR
 - 8318209 CORDON D'ALIMENTATION
 - 8272124 CONTACTEUR COUVERCLE
 - 8542693 MODULE DE COMMANDE DE LA MACHINE
 - 8541034 CONTROLÉUR DU MOTEUR ET BASE DE MONTAGE
 - 8300022 CONTACTEUR D'INTERVERROUILLAGE
 - 9724754 VANNE LOG
 - 8055146 FILTRE EN SERIE
 - (8528338 FILTRE EN SERIE ALTERNÉ.)

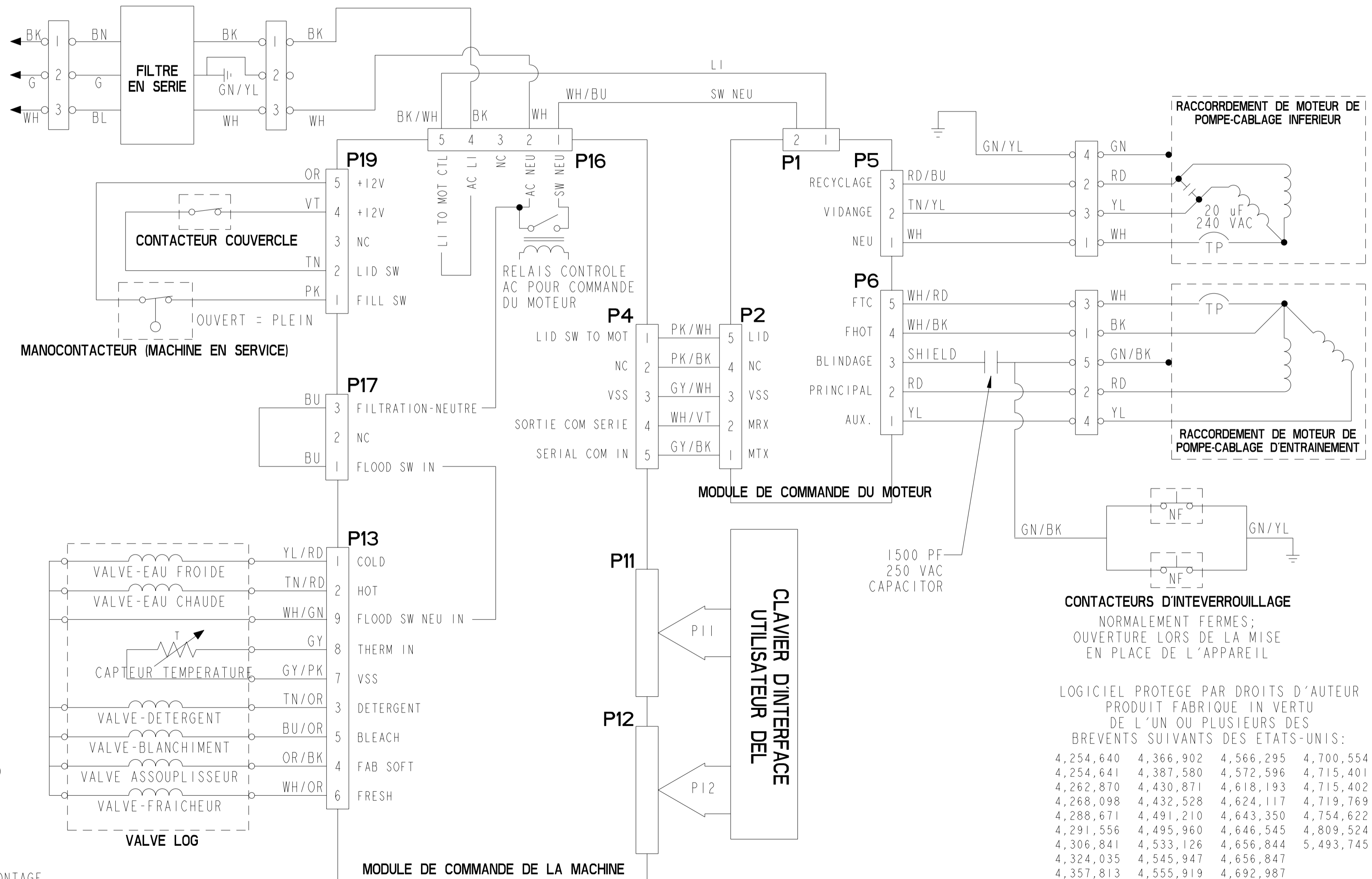

LOGICIEL PROTEGE PAR DROITS D'AUTEUR
 PRODUIT FABRIQUE IN VERTU
 DE L'UN OU PLUSIEURS DES
 BREVETS SUIVANTS DES ETATS-UNIS:

4,254,640	4,366,902	4,566,295	4,700,554
4,254,641	4,387,580	4,572,596	4,715,401
4,262,870	4,430,871	4,618,193	4,715,402
4,268,098	4,432,528	4,624,117	4,719,769
4,288,671	4,491,210	4,643,350	4,754,622
4,291,556	4,495,960	4,646,545	4,809,524
4,306,841	4,533,126	4,656,844	5,493,745
4,324,035	4,545,947	4,656,847	
4,357,813	4,555,919	4,692,987	