

LEGEND

- COMPONENT MAY OR MAY NOT BE USED
- TIMER CONSTRUCTION
- TERMINAL CONNECTION
- SPLICE
- ∞ IN LINE CONNECTION

TIMER POSITION	TIMER SWITCH						
	TM-OR	TM-WB	BK-BU-V	BK-BU	BK-R	T-BY	T-W
AUTO-REGULAR							
AUTO-SOFT/LOW HEAT							
COOL DOWN AIR	⊙	⊙	■				
END OF CYCLE							
TIMED-REGULAR							
TIMED-SOFT/LOW HEAT							
GUARD							+

- LEGEND
- = OPEN
 - ▨ = CLOSED
 - = DOESN'T MATTER
 - ⊙ = EITHER (NOT BOTH)
 - ⊕ = CLOSED INTERMITTENTLY

MANUFACTURED UNDER ONE OR MORE OF THE FOLLOWING U.S. PATENTS:

3,702,030	3,890,720	4,132,008
3,762,064	3,959,891	4,385,452
3,769,716	3,962,617	4,430,809
3,815,258	4,003,613	4,821,535
3,889,392	4,086,709	

CAUTION: LABEL ALL WIRES PRIOR TO DISCONNECTION WHEN SERVICING CONTROLS. WIRING ERRORS CAN CAUSE IMPROPER AND DANGEROUS OPERATION. VERIFY PROPER OPERATION AFTER SERVICING.

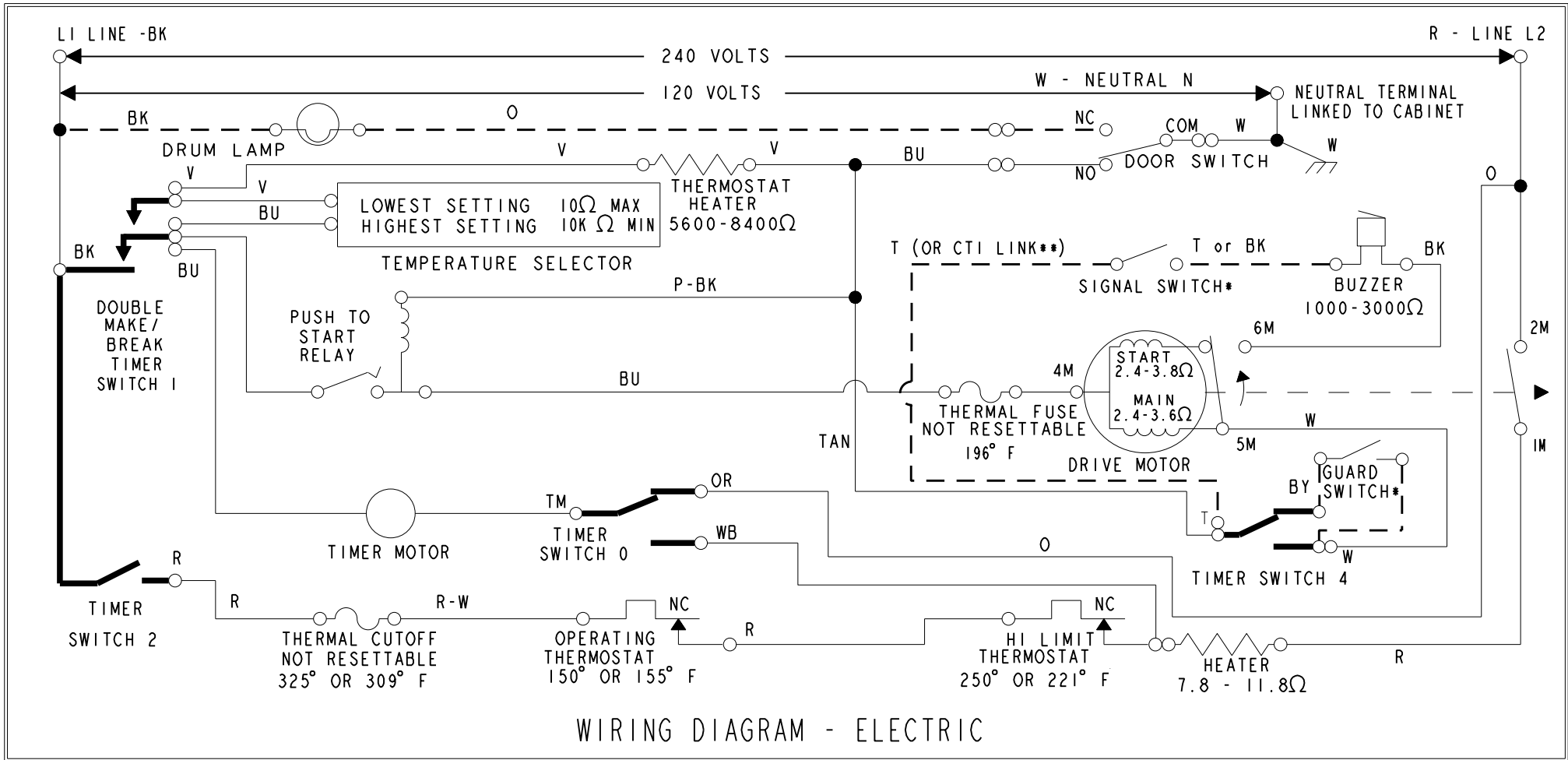

WIRING DIAGRAM - ELECTRIC

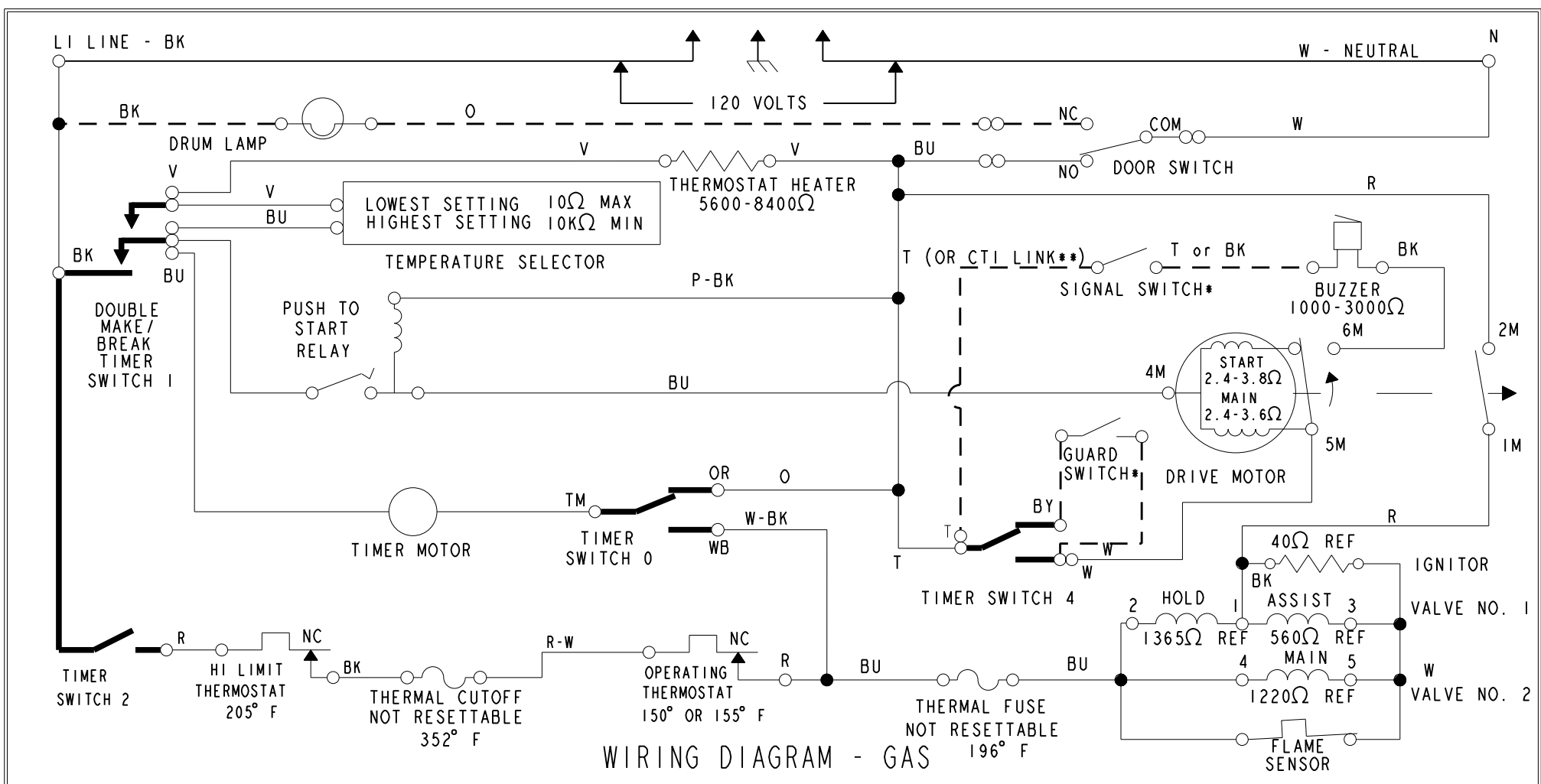

WIRING DIAGRAM - GAS

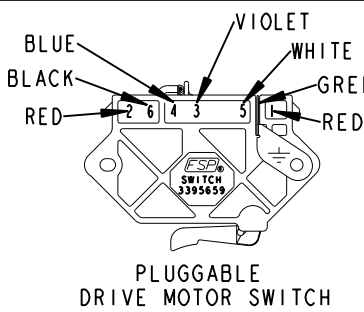

PLUGGABLE DRIVE MOTOR SWITCH

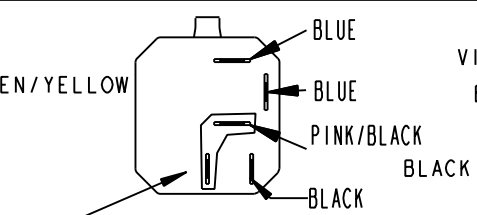

**TAN WIRE MAY BE REPLACED WITH STAKE FROM PINK/BLACK TERMINAL ON PUSH-TO-START RELAY. TERMINAL AND JUMPER MAY NOT BE ON ALL PUSH TO START RELAYS.

PUSH TO START RELAY

* SWITCH MAY BE REPLACED WITH JUMPER

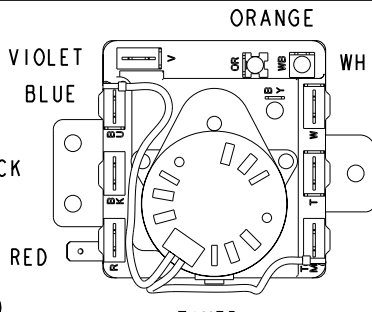

TIMER

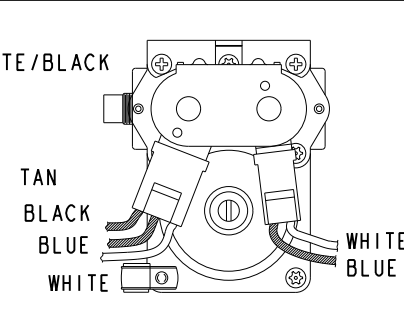

GAS VALVE

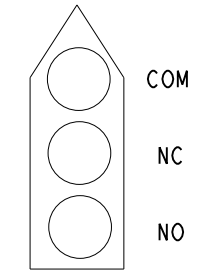

DOOR SWITCH CONNECTOR

PART NO. **8576811**
REV REL