

LEGEND / LEGENDE / LEYENDA

- TIMER SWITCH
COMMUTEUR DE LA MINUTERIE
INTERRUPTOR DEL TEMPORIZADOR
- INT. COMP CONNECTION
CONNEXION INTERNE DE COMPOSANT
CONEXION INTERNA DEL COMPONENTE
- HARNESS WIRING
CABLAGE
CABLEADO DEL ARNES
- HARNESS CONNECTION
CONNEXION DE
CONNEXION DU CABLAGE
- TERMINAL CONNECTION
BROCHE DE CONNEXION
CONEXION TERMINAL
- WASH RINSE / RINCAGE DE LAVAGE
/ ENJUAGUE DEL LAVADO

- WATER LEVEL SWITCH
SELECTEUR DE NIVEAU D'EAU
INTERRUPTOR DEL NIVEL DE AGUA
- FULL / PLEIN / LLENO
- EMPTY / VIDE / VACIO
- LID SWITCH
CONTACTEUR DU COUVERCLE
INTERRUPTOR DE LA TAPA
- TIMER MOTOR
MOTEUR DE MINUTERIE
MOTOR DEL TEMPORIZADOR
- CENTRIFUGAL SWITCH
CONTACTEUR ESSORAGE
INTERRUPTOR CENTRIFUGO
- CABINET GROUND
MASSE CAISSE
CONEXION A TIERRA
DEL GABINETE
- CAPACITOR / CONDENSATEUR /
CONDENSADOR

- DRIVE MOTOR / MOTEUR / MOTOR DE ACCIONAMIENTO
- L LOW / BASSE / BAJA
- M MEDIUM / MOYENNE / MEDIA
- H HIGH / HAUTE / ALTA
- S START / DEMARRENT / ARRANQUE

- HOT VALVE
ELECTROVANNE EAU CHAUDE
VALVULA DE AGUA CALIENTE
- C COLD VALVE
ELECTROVANNE EAU FROIDE
VALVULA DE AGUA FRIA

- ATC SENSOR / CAPTEUR D'ATC / SENSOR DEL ATC
- ATC SWITCH / PANNEAU D'ATC / INTERRUPTOR de ATC

- FLOW METER
MÈTRE D'ÉCOULEMENT
METRO DE FLUJO
- LS LOAD SENSE
SENS DE CHARGE
SENTIDO DE CARGA

- BLEACH DISPENSE CIRCUIT
NOT USED ALL MODELS
- L'AGENT DE BLANCHIMENT
DISTRIBUE LE CIRUIT
NON UTILISE TOUS LES MODELS
- TSC TEMPERATURE SWITCH CHART
TABLEAU-SELECTEUR DE
TEMPERATURE
CUADRO DEL INTERRUPTOR
DE TEMPERATURA

3949180 EXTRA RINSE	
OFF	PI
ON	X

3949180 FABRIC SOFTENER	
OFF	P2
ON	X

W10248240					
ATC/LS CONTROL	BULKY	NORMAL / HANDWASH	CASUAL / DELICATE / ULTRA	RINSE	
1	COLD	COLD	COLD	COLD	COLD
2	COOL1	60°F	60°F	60°F	COLD
3	COOL2	70°F	61°F	70°F	COLD
4	COOL3	78°F	62°F	82°F	COLD
5	WARM	100°F	85°F	97°F	COLD
6	HOT	HOT°F	100°F	115°F	COLD

MANUFACTURADO BAJO UNA O MAS DE
LAS SIGUIENTES PATENTES MEXICANAS:
159840, 159983, 161744, 163722, 164305,
164407, 165930, 165992, 170211, 174136,
174418, 174483, 177764, 177766, 181185,
182183, 182396, 182632, 187728, 189682,
189166, 192502, 192503, 198353, 198644,
205519, 211042

FABRIQUE SOUS UN OU PLUSIEURS
DES BREVETS CANADIENS SUIVANTS:
1228410, 1233039, 1233658, 1282557,
1287338, 1288866, 1296966, 1301469,
1304367, 1313710, 2018975, 2022266,
2043393, 2056469, 2086151, 076618

MANUFACTURED UNDER ONE OR MORE OF THE FOLLOWING US PATENTS:

4545947, 4555919, 4566295, 4572596, 4618193, 4624117, 4643350,
4646545, 4656844, 4656847, 4692987, 4693095, 4697293, 4700554,
4709951, 4715401, 4719769, 4754222, 4759202, 4774822, 4779431,
4782544, 4784666, 4785643, 4793820, 4807452, 4809524, 4835991,
4854559, 4856302, 4870988, 4888965, 4890465, 4891859, 4910979,
4945725, 4947516, 4963241, 4971234, 4971394, 4980693, 4987627,
5000016, 5031427, 5033277, 5074003, 5075613, 5113542, 5130624,
5130588, 514071, 5166568, 5167722, 5172573, 5177659, 5191667,
5191668, 5191669, 5193361, 5194271, 5195281, 5200864, 5205141,
5219370, 5237118, 5249441, 5255844, 5257901, 5259217, 5269160,
5271251, 5291402, 5305485, 5312738, 5314044, 5345637, 5345792,
5349793, 5359744, 5371715, 5400181, 5493765, 5501053,
5515565, 5582039, 5582199, 5651278, 5671494, 5165404, 5184902,
5791167, 5836180, 5852942, 5875865, 5878602, 5883490, 5885946,
6095171, 6070282, 6105405, 6115862, 6125490, 6185774, 6217222,
6227013, 6227014, 6269666, 6347645, 6363563, 6393872, 6430971,
6505370, 6597144, 6604298, 6685241, 6732447, 6784673, 6819255,
6840068, 6846790, 6860032, 6863197, 6900166, 6964360, 6966204,
6973740, 6973515, 7020985, 7080464, 7097667, 0314263, 0375390,
0381140, 0423740, 0426686, 0456572, 0459844, 0463631, 0465308,
0474566, 0495453, 0518250, 0502577, 0514756, 0521196, 0523595,
0524001, 0527853

CYCLE	WASH ACTION SWITCH W10180780										
	MOTOR SPEED	AGI	SPIN	S1	S2	S3	S4	S5	S6	S7	S8
HANDWASH	INT LOW	LOW	X		X	X		X			X
DELICATE	LOW	LOW	X					X		X	
CASUAL	HIGH	LOW	X						X	X	
NORMAL	HIGH	HIGH	X	X	X				X	X	
ULTRA	HIGH	HIGH	X						X	X	
BULKY	HIGH	HIGH	X	X	X				X	X	

TIMER KNOB PUSH OFF ALL TIMER SWITCHES OPEN
BOUTON DE LA MINUTERIE ENFONCE (ARRET)-TOUS LES
AUTRES COMMUTEURS DE LA MINUTERIE OUVERTS
PERILLA DEL TEMPORIZADOR OPRIMIDA (APAGADO)-TODOS
LOS INTERRUPTORES DEL TEMPORIZADOR ABIERTOS

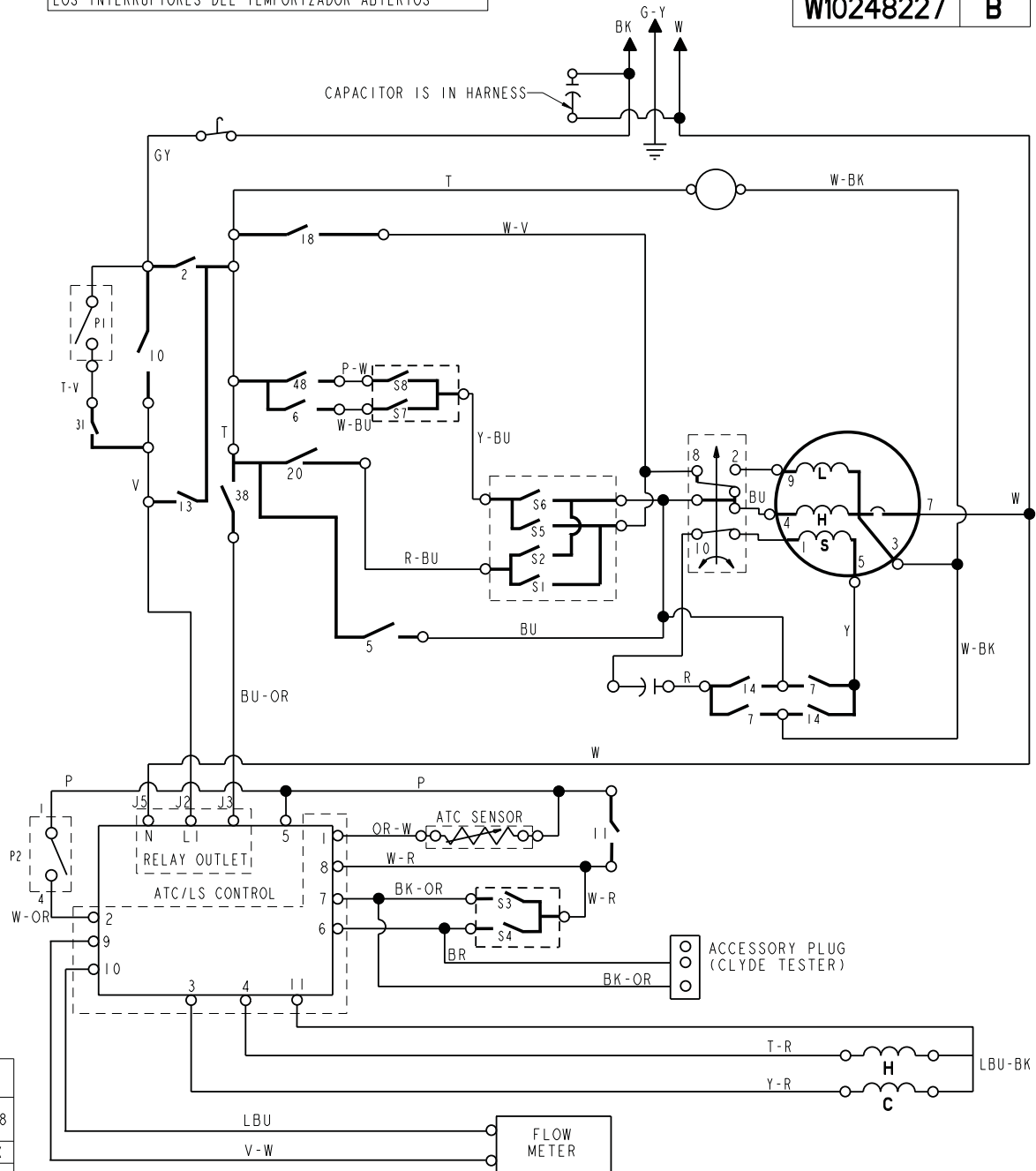

PART No. PIECE N° PIEZA N°	REV. REV. REV.
W10248227	B

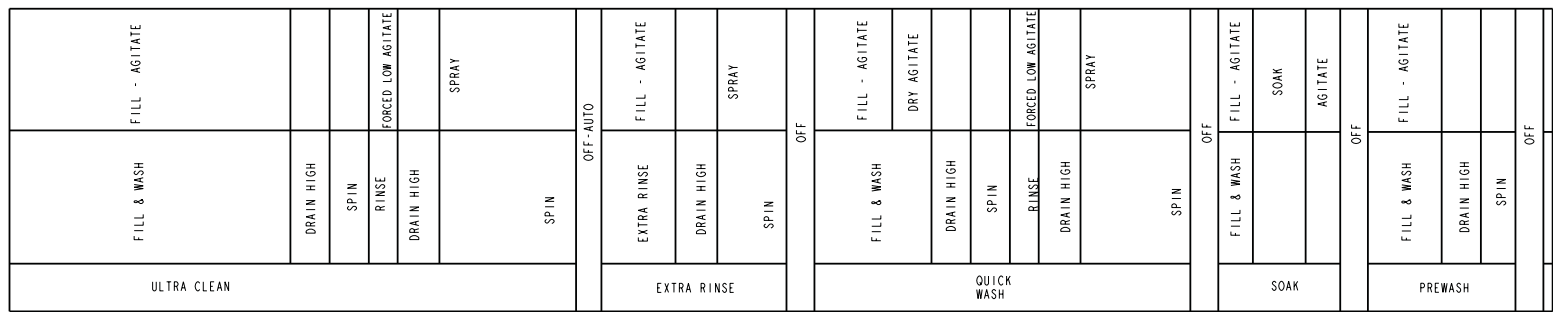
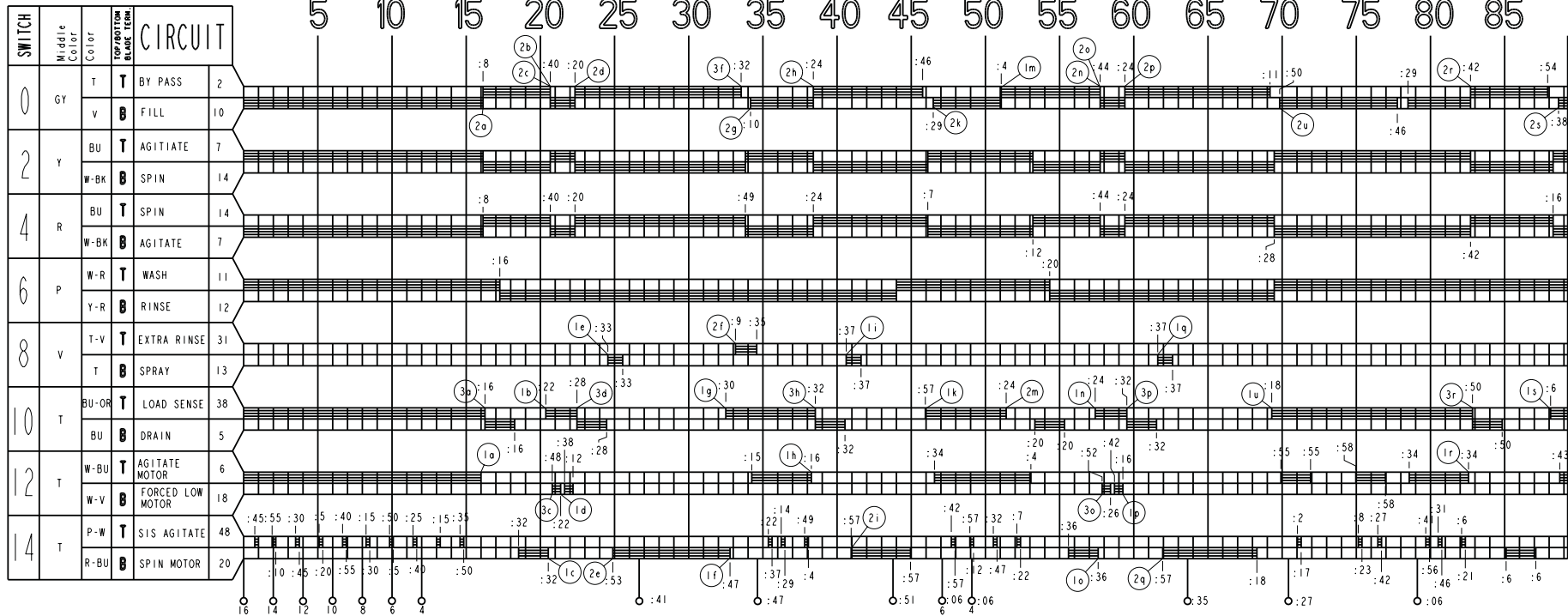

WARNING - DISCONNECT FROM ELECTRICAL SUPPLY BEFORE SERVICING UNIT.



ENGLISH	FRENCH	SPANISH
AGITATE	AGITER	AGITAN
BLEACH	BLANCHIMENT	BLANQUEO
BUIZZER	VIBEUR	SEÑAL SONORA
BYPASS	DERIVATION	PUENTE
DRAIN	VIDENT	DREÑAN
EXTRA RINSE	RINCAGE DE PLUS	ADICIONAL ACLARACION
FILL	REMPLISSAGE	LLENAN
HIGH	HAUT	ALTO
INT AGITATE	AGITER INTERMITTENT	INTERMITENTE AGITE
LO	LENT	BAJO
MED	MED	MEDIA
MOTOR	MOTEUR	MOTOR
NORMAL	NORMALE	NORMAL
PERMANENT PRESS	SYNTHETIQUES	PERMANENT PRENSA
PREWASH	PRE LAVAGE	PRE COLADA
RINSE	RINCAGE	ACLARACION
SOAK	IMBIBERT	REMOJAN
SPIN	ESSORAGE	VUELTA
SPRAY	CICLAGE	AEROSOL
WASH	LAVAGE	COLADA
TIMED FILL	SYNCHRONISES REMPLISSAGE	SINCRONIZADO TERRAPLEN

KEY
 CONTACT OPEN ON CHART
 CONTACT CLOSED ON CHART

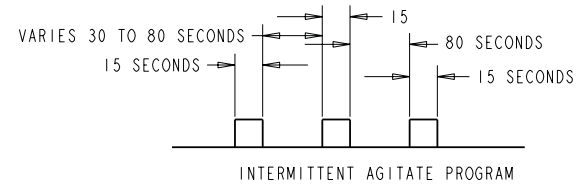

INTERMITTENT AGITATE PROGRAM