

⚠ WARNING



Electrical Shock Hazard
 Disconnect power before servicing.
 Replace all parts and panels before operating.
 Failure to do so can result in death or electrical shock.

IMPORTANT

Electrostatic Discharge (ESD) Sensitive Electronics

Do not open package until it is time to install the electronic board.

ESD problems are present everywhere. ESD may damage or weaken the electronic board. The new board may appear to work well after repair is finished, but failure may occur at a later date due to ESD stress.

- Use an anti-static wrist strap. Connect wrist strap to green ground connection point or unpainted metal in the appliance

-OR-

Touch your finger repeatedly to a green ground connection point or unpainted metal in the appliance.

- Before removing the part from its package, touch the anti-static bag to a green ground connection point or unpainted metal in the appliance.
- Avoid touching electronic parts or terminal contacts; handle electronic board by edges only.
- When repackaging failed electronic board in anti-static bag, observe above instructions.

DIAGNOSTIC GUIDE

Before servicing, check the following:

- Make sure there is power at the wall outlet.
- Has a household fuse blown or circuit breaker tripped? Time delay fuse?
- Is dryer vent properly installed and clear of lint or obstructions?
- All tests/checks should be made with a VOM or DVM having a sensitivity of 20,000 ohms per volt DC or greater.
- Check all connections before replacing components. Look for broken or loose wires, failed terminals, or wires not pressed into connectors far enough.
- The most common cause for control failure is corrosion on connectors. Therefore, disconnecting and reconnecting wires will be necessary throughout test procedures.
- Connectors: Look at top of connector. Check for broken or loose wires. Check for wires not pressed into connector far enough to engage metal barbs.
- Resistance checks of components must be made with power cord unplugged from outlet.

LESS DRY TEST

Begin with a fully assembled, empty dryer with clean lint screen. Be sure dryer is connected to a known good power source.

1. Set the following configuration:
 - Door - must be closed
 - Timer - Less Dry
 - Temperature switch - Senseon High
 - End of Cycle Signal switch - Louder
2. Press the Push to Start (PTS) switch. After approximately 16 seconds, the Timer will start to advance to the Off position. If this function does not occur, proceed to the Diagnostic Test.

DIAGNOSTIC TEST

This test allows factory/service personnel to test and verify all inputs to the electronic control. The basic operation of this test is to notify the operator with an audible beep every time the status of an input to the control changes state.

This test is performed with a fully assembled dryer, connected to a known good power source.

Activating the Test Mode

1. Set the following configuration:
 - Door - must be open
 - End of Cycle Signal switch - Louder
 - Timer - Timed Drying or AccuDry Sensor Drying selection
2. Turn the Wrinkle Shield switch from Off to 120 Minute three times within a five second period. A double beep, a pause, then a single beep will sound to indicate that the test mode is activated.

NOTE: If any of these initial conditions are not satisfied, the control will not enter the test mode.

Test Mode Functionality

When the control is in test mode, every input change of state will result in an audible beep (with the exception of the End of Cycle Signal switch). This includes:

- Door switch
- Moisture Sensor (short/open Sensor will result in a beep)
 - NOTE:** A moistened finger or damp cloth may also be used.
- Temperature switch
- Wrinkle Shield switch
- Push to Start (PTS) switch (with the door switch closed)
- Timer (any cam input change will result in a beep)
 - NOTE:** Timer will advance during test.

If any of the inputs do not result in a beep, proceed to the corresponding component tests, beginning on page 4.

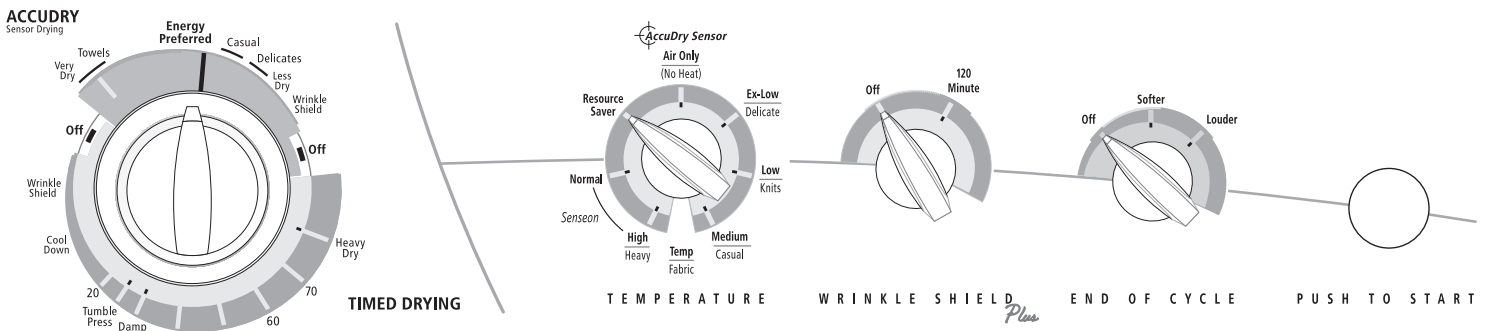

Gas Dryer Wiring Diagram

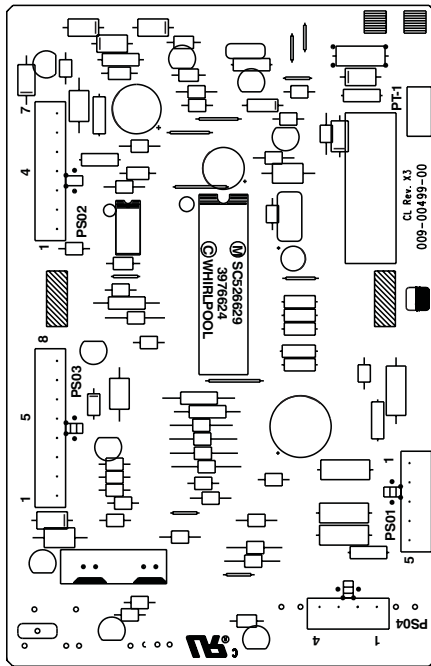
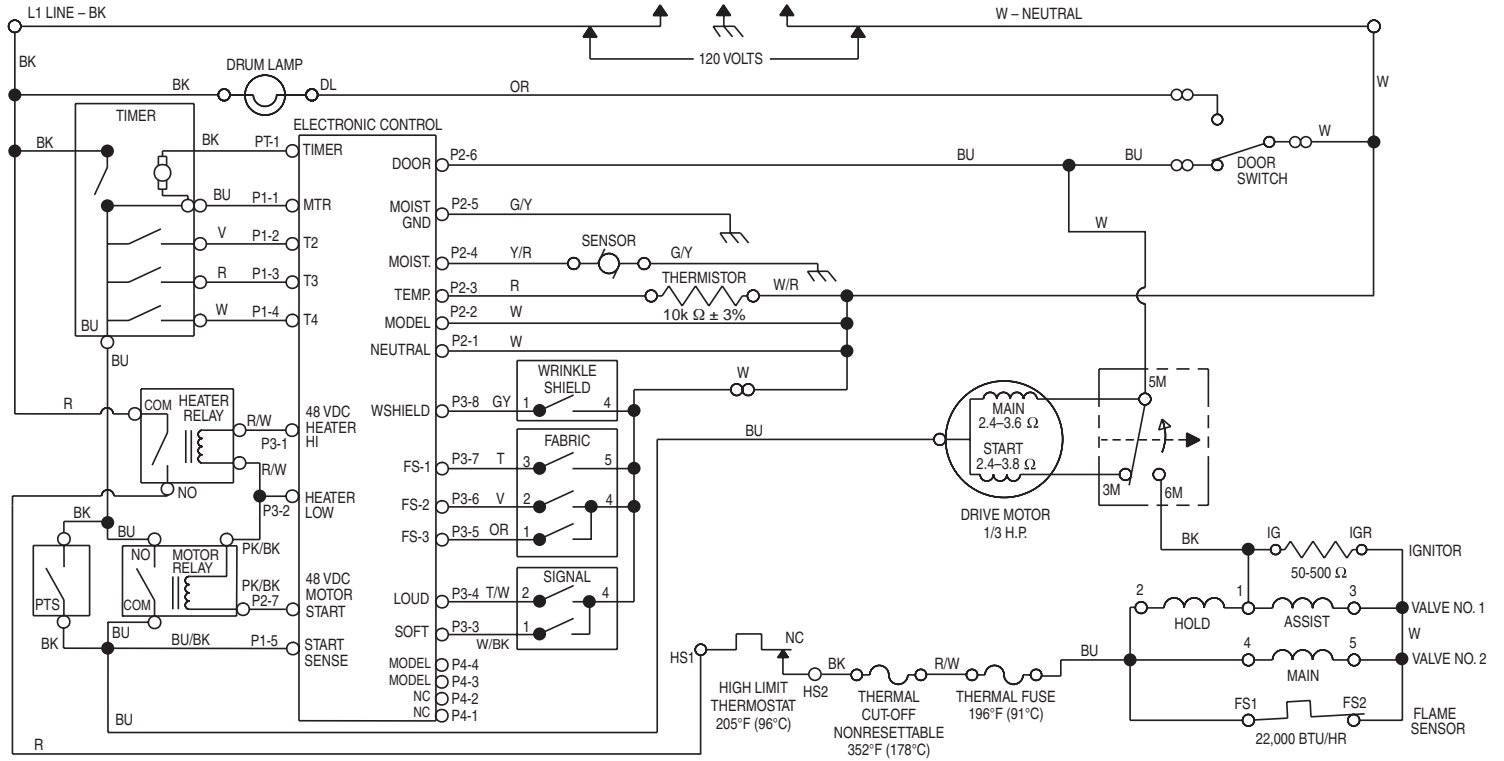

Electronic Control Assembly

Function	Contacts				
	1M	2M	3M	5M	6M
Start			●		
Run	●			●	

● = Contacts closed

Centrifugal Switch (Motor)

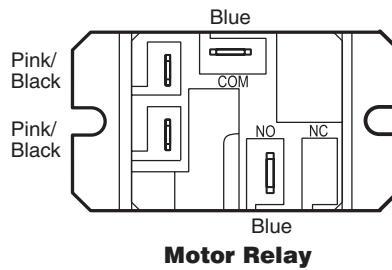

Motor Relay

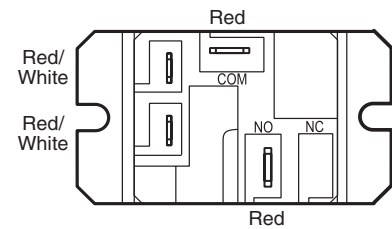

Heater Relay

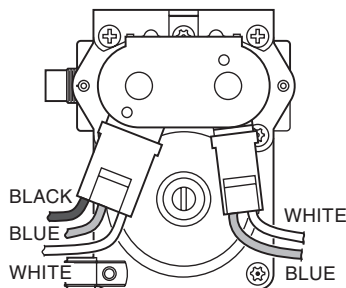

Gas Valve

Drum Size: 7 cubic feet
Drum Speed: 48 ± 3 RPM CCW

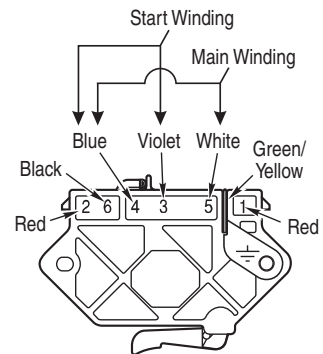

Pluggable Drive Motor Switch

Timer	BU	BK	R	V	W
Wire Colors	Blue	Black	Red	Violet	White

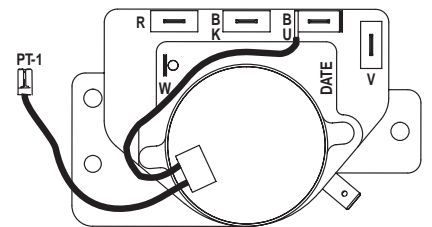

Timer

MOTOR STRIP CIRCUIT

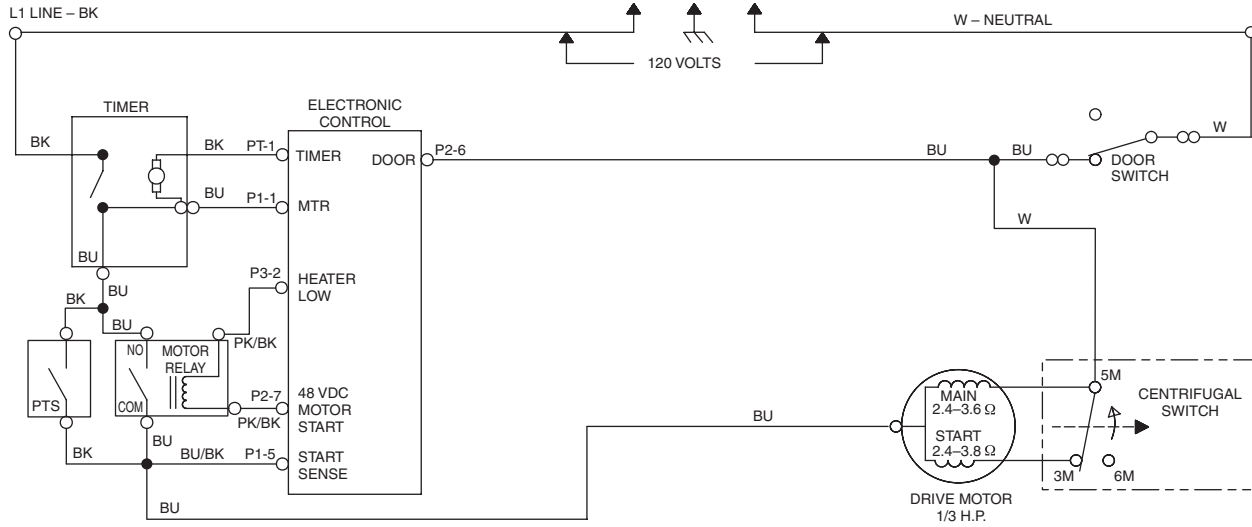

HEATER STRIP CIRCUIT

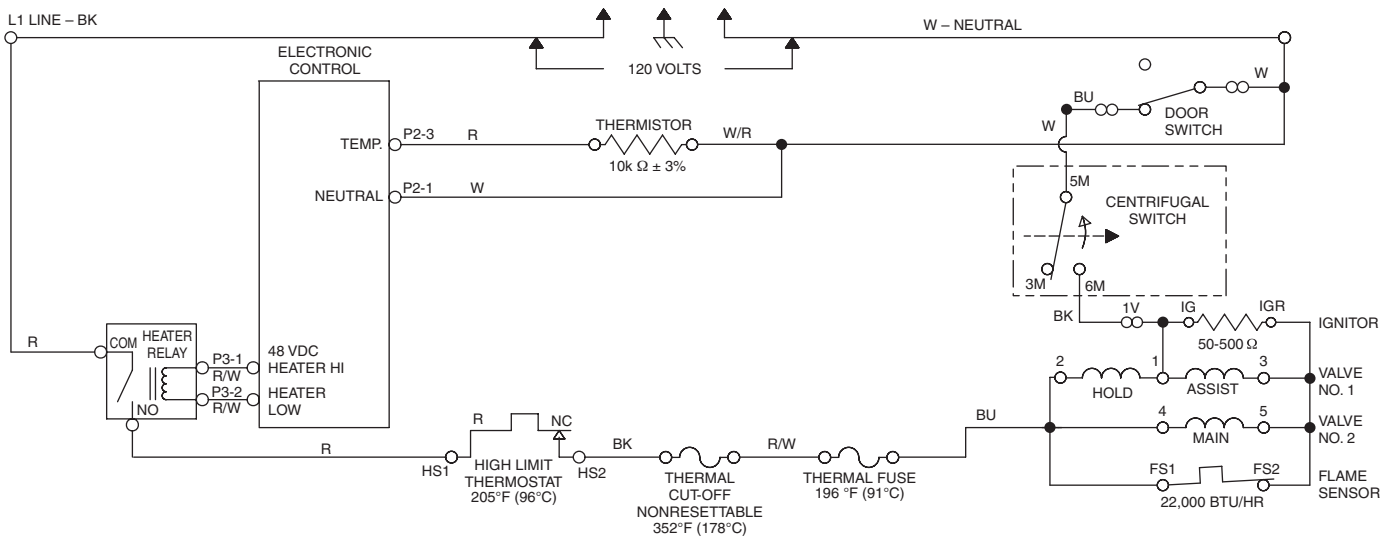

MOISTURE SENSOR STRIP CIRCUIT

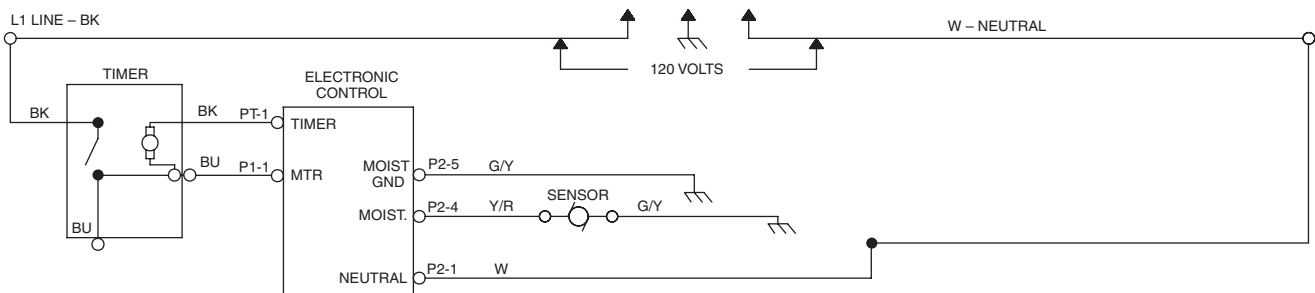

Component Location

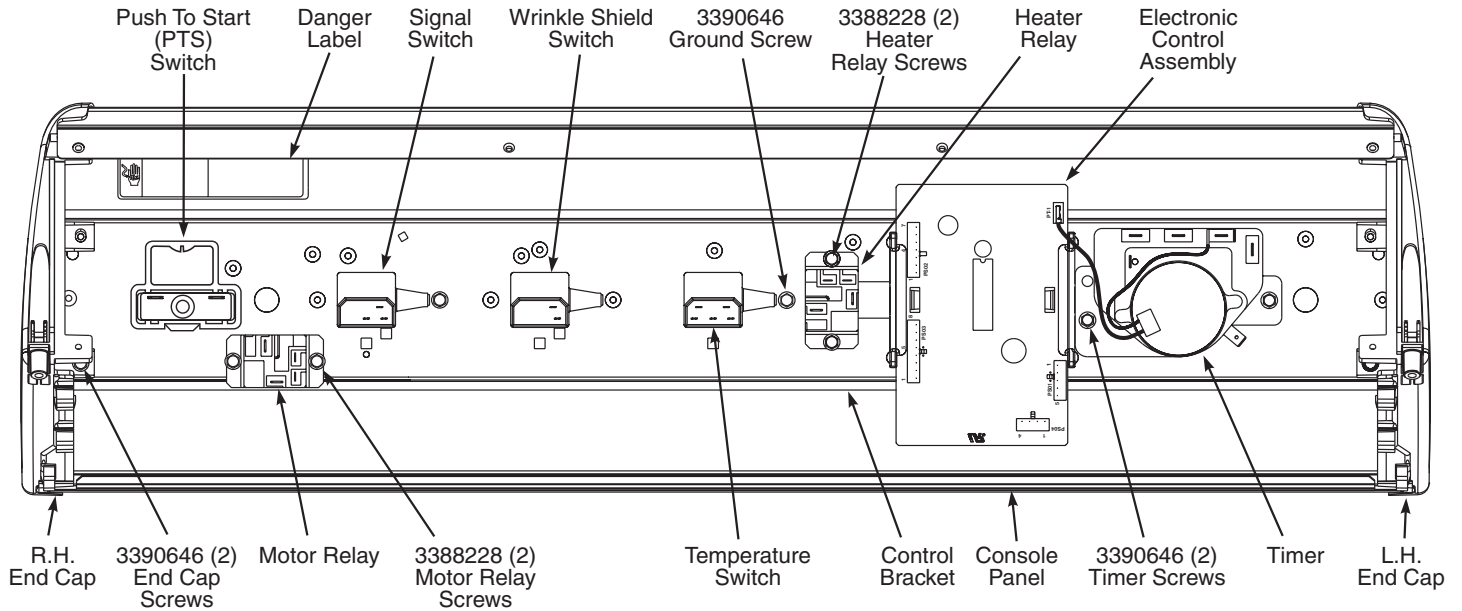

COMPONENT	PART NUMBER	
	MODEL NO. GGW9878PW (White)	MODEL NO. GGW9878PG (Biscuit)
Console Panel	8545982	8545984
End Cap - R. H.	8271359	8271362
End Cap - L. H.	8271365	8271368
PTS Switch	3977456	3977456
PTS Knob *	8544941	8544942
Control Knob *	8544937 (3)	8544938 (3)
Control Bracket	8544895	8544895
End of Cycle Signal Switch	3405151	3405151
Wrinkle Shield Switch	3405152	3405152
Temperature Switch	8299970	8299970
Motor Relay	3405281	3405281
Heater Relay	3405281	3405281
Electronic Control Assembly	3976623	3976623
Timer Knob *	8544957	8544958
Console Harness *	8283281	8283281
Main Harness *	8299900	8299900
Door Switch *	3406107	3406107
Thermal Cut-Off *	3977394	3977394
Thermal Fuse *	3390719	3390719
Gas Burner Assembly *	8318272	8318272
High Limit Thermostat *	3403140	3403140
Drive Motor *	8538262	8538262
Thermistor - NTC 10k Ohms *	3976615	3976615
Timer	8299771	8299771

* not shown in illustration

COMPONENT TESTS

Supply Connections Test

1. Unplug dryer or disconnect power.
2. Remove the cover plate from the back of the dryer and check that the power cord is firmly connected to the dryer's wire harness.
3. Access the electronic control without disconnecting any wiring to the control board.
4. With an ohmmeter, check for continuity between the neutral (N) terminal of the plug and P2-1 (white wire) on the control board. The left-hand side of the illustration at right shows the position of the neutral terminal (N) on the power cord plug.
 - If there is continuity, go to step 5.
 - If there is no continuity, disconnect the white wire of the harness from the power cord. Test the continuity of the power cord neutral wire as illustrated above. If an open circuit is found, replace the power cord. Otherwise, replace the main harness.
5. In a similar way, check the continuity between the L1 terminal of the plug and BK (black wire) on the timer.
 - If there is continuity, go to the Timer Test.
 - If there is no continuity, disconnect the black wire of the harness from the power cord. Test the continuity of the power cord L1 wire as illustrated above. If an open circuit is found, replace the power cord. Otherwise, replace the main harness.

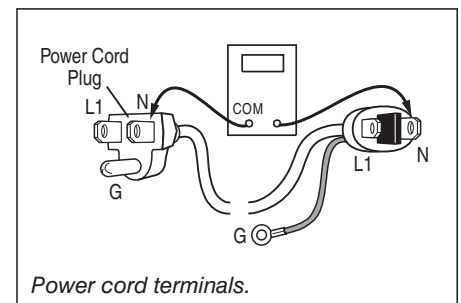

Timer Test

Perform the diagnostic test on page 1 to determine that the timer motor advances (should run continuously). If the timer does not advance or fails the diagnostic test:

1. Unplug dryer or disconnect power.
2. Remove the wires from timer terminals.
3. Check the timer motor resistance and timer switching. The resistance (BU to PT-1) should be 3 k ohms (±2). Use the timer encoding table below for switching conductivity, and refer to timer illustration on page 2.

Reference contact continuity to timer - BK.

Timer Encoding Table

TIMED DRYING MODE					
Timer Contacts	Timed Drying	Cool Down	Wrinkle Shield	Off	
W to BK	O	O	O	O	
R to BK	X	X	O	O	
V to BK	O	X	X	O	
BU to BK	X	X	X	O	
ACCU-DRY SENSOR DRYING MODE					
Timer Contacts	Very Dry	Energy Preferred	Less Dry	Wrinkle Shield	Off
W to BK	X	X	O	O	O
R to BK	O	O	O	O	O
V to BK	X	O	O	X	O
BU to BK	X	X	X	X	O

O = OPEN X = CLOSED

Motor Test

1. Unplug dryer or disconnect power.
2. Open the dryer door.
3. Measure resistance between the motor relay common (COM) terminal and the P2-6 terminal on the electronic control. 1 to 6 ohms should be measured.
 - ➔ If resistance measurements are outside 1 to 6 ohms, perform the Door Switch Test and check harness continuity. If they test good, replace the motor.
4. Measure resistance between the motor relay common (COM) terminal and ground. A high resistance (open) should be measured.
 - ➔ If it does not, perform the Door Switch Test and check harness continuity. If they test good, replace the motor.

Door Switch Test

1. Unplug dryer or disconnect power.
2. Check door switch continuity. Neutral to P2-6 on the electronic control should read closed with the door closed, and open with the door open.
3. Otherwise, verify harness continuity.
 - ➔ If no continuity, repair or replace the harness.
 - ➔ If harness is good, replace the door switch.

Temperature Switch Test

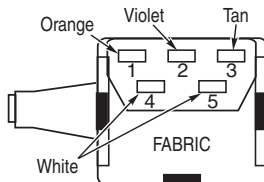

1. Unplug dryer or disconnect power.
2. Remove the wires from the switch to complete this test.
3. Reference contact continuity with Pins 1 and 2 to Pin 4 (White).
4. Reference contact continuity with Pin 3 to Pin 5.

Temperature Switch Table

SWITCH POSITION	CONTACTS			FUNCTION
	3-5	2-4	1-4	
12 o'clock	O	O	O	Air Only (No Heat)
2 o'clock	O	O	X	Ex-Low, Delicate
4 o'clock	O	X	O	Low, Knits
5 o'clock	O	X	X	Medium, Casual
7 o'clock	X	O	O	High, Senseon
8 o'clock	X	O	X	Normal, Senseon
10 o'clock	X	X	O	Resource Saver

O = OPEN X = CLOSED

Wrinkle Shield Switch (On/Off) Test

1. Unplug dryer or disconnect power.
2. Remove the wires from the switch to complete this test.
3. Reference contact continuity with Pin 1 to Pin 4 (White).

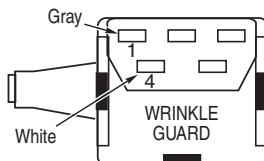

Wrinkle Shield Switch Table

SWITCH POSITION	CONTACTS	FUNCTION
11 o'clock	Open	Wrinkle Shield Off
1 o'clock	Closed	Wrinkle Shield 120 Minute

"End of Cycle" Signal Switch Test

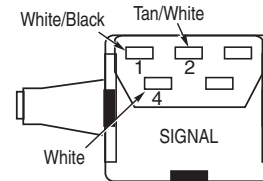

1. Unplug dryer or disconnect power.
2. Remove the wires from the switch to complete this test.
3. Reference contact continuity with Pins 1 and 2 to Pin 4 (White).

End of Cycle Signal Switch Table

SWITCH POSITION	CONTACTS		FUNCTION
	1-4	2-4	
10 o'clock	O	O	Off
12 o'clock	X	O	Softer End of Cycle Signal
2 o'clock	O	X	Louder End of Cycle Signal

O = OPEN X = CLOSED

High Limit Thermostat Test

1. Unplug dryer or disconnect power.
2. Remove the high limit thermostat and check continuity. Refer to the Thermal Components illustration below.
 - ➔ If open, replace the high limit thermostat.
 - ➔ If closed, apply heat. It should open at about 205°F (96°C). Otherwise, replace the high limit thermostat.

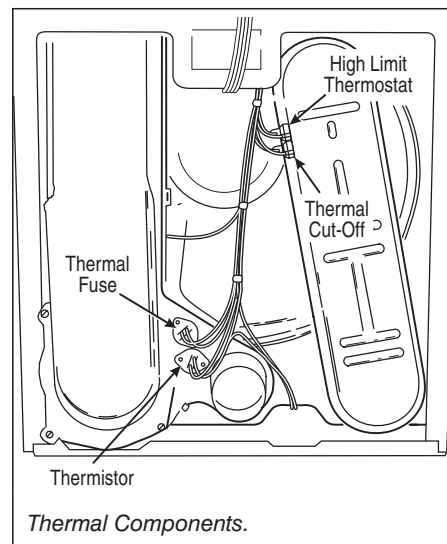

Thermal Cut-Off Test

This unit is equipped with a "one-shot" thermal cut-off. See Thermal Components illustration, page 5. If the dryer does not heat with power supplied:

1. Unplug dryer or disconnect power.
2. Check the thermal cut-off for continuity. If open, thermal cut-off has failed and must be replaced.

NOTE: If the thermal cut-off has failed, replace the thermal cut-off and high limit thermostat. In addition, check for failed heat system, or blocked or improper exhaust system.

Thermal Fuse Test

A thermal fuse is used on this model. The thermal fuse is wired in series with the dryer gas valve. If the thermal fuse opens, power is shut off to the gas valve.

1. Unplug dryer or disconnect power.
2. Check continuity of thermal fuse.
3. Once the thermal fuse has opened, it must be replaced. Check for failed thermistor or other causes of failure. Replace failed parts. See Thermal Components illustration, page 5.

Thermistor Test or Dryer Beeps 3 Times when Push to Start (PTS) Pressed

An electronic temperature sensor called a thermistor is used in this model in place of an operating thermostat. The electronic control monitors the exhaust temperature using the thermistor, and cycles the heater relay on and off to maintain the desired temperature.

Procedure

Begin with a fully assembled, empty dryer and a clean lint screen.

1. Set the following configuration:
 - Door - must be closed
 - Timer dial - Timed Drying
 - Temperature switch - Senseon High
 - Wrinkle Shield switch - Off
 - End of Cycle Signal switch - Louder
2. Press the Push to Start switch.
 - ➔ If you hear three short beeps and the dryer shuts off after several seconds, the thermistor or wire harness is either shorted or open.
 - Unplug dryer or disconnect power.
 - Check wire connections at the electronic control and thermistor.
 - If wiring is functional, replace the thermistor. Refer to Thermal Components illustration, page 5.

➔ If the dryer appears to operate correctly, proceed to step 3.

3. Remove exhaust vent and start the dryer.

➔ Turn Temperature switch to desired temperature to be tested, and select 20 minutes of Timed Drying. Hold a glass bulb thermometer capable of reading from 90°F to 180°F (32°C to 82°C) in the center of the exhaust outlet. Measure exhaust temperatures with heater off and on.

The correct exhaust temperatures are as follows:

TEMP. SWITCH SETTING	HEAT TURNS OFF	HEAT TURNS ON
Senseon High	150° ± 10°F (66° ± 6°C)	10°-15°F (6°-8°C) below heat off
Senseon Normal/Medium	140° ± 10°F (60° ± 6°C)	
Resource Saver	135° ± 10°F (57° ± 6°C)	
Low	125° ± 10°F (52° ± 6°C)	
Extra Low	115° ± 10°F (46° ± 6°C)	

➔ If the exhaust temperature is not within specified limits, disconnect dryer from power and check the resistance of the thermistor.

THERMISTOR RESISTANCE			
TEMP. °F (°C)	RES. k Ω	TEMP. °F (°C)	RES. k Ω
50° (10°)	19.9	100° (38°)	5.7
60° (16°)	15.3	110° (43°)	4.7
70° (21°)	11.9	120° (49°)	3.7
80° (27°)	9.2	130° (54°)	3.1
90° (32°)	7.4	140° (60°)	2.5

➔ If the thermistor resistance checks within normal limits, replace the electronic control assembly.

Gas Valve Test

1. Unplug dryer or disconnect power.
2. Use an ohmmeter to determine if a gas valve coil has failed. Remove harness plugs. Measure resistance across terminals. Readings should match those shown in the following chart. If not, replace coil.

Terminals	Resistance
1 to 2	1365Ω ± 25
1 to 3	560Ω ± 25
4 to 5	1220Ω ± 50

IMPORTANT:

Be sure all harness wires are looped back through the strain relief after checking or replacing coils.

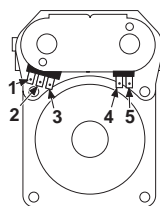

IMPORTANT: Electrostatic (static electricity) discharge may cause damage to electronic control assemblies. See page 1 for details.

TROUBLESHOOTING GUIDE

PROBLEM	POSSIBLE CAUSE / TEST
DRYER WILL NOT RUN.	Refer to Motor Strip Circuit, page 3. - SUPPLY CONNECTIONS - HARNESS/CONNECTION - MOTOR RELAY - PUSH TO START (PTS) SWITCH - MOTOR - DOOR SWITCH - ELECTRONIC CONTROL For more details, see Troubleshooting section, page 7.
DRYER WILL NOT HEAT.	Refer to Heater Strip Circuit, page 3. - SUPPLY CONNECTIONS - HARNESS/CONNECTION - HEATER RELAY - THERMAL CUT-OFF - THERMAL FUSE - HIGH LIMIT THERMOSTAT - GAS VALVE - CENTRIFUGAL SWITCH - THERMISTOR - ELECTRONIC CONTROL For more details, see Troubleshooting section, page 7.
DRYER HEATS DURING AIR FLUFF/NO HEAT CYCLE.	Refer to Heater Strip Circuit, page 3. - HARNESS/CONNECTION - HEATER RELAY - TEMPERATURE SWITCH - ELECTRONIC CONTROL For more details, see Troubleshooting section, page 7.
DRYER WON'T SHUT OFF.	Refer to Motor and Moisture Sensor Strip Circuits, page 3. - PUSH TO START (PTS) SWITCH - HARNESS/CONNECTION - MOTOR RELAY - MOISTURE SENSOR - ELECTRONIC CONTROL For more details, see Troubleshooting section, page 7.
DRYER SHUTS OFF BEFORE CLOTHES ARE DRY.	Refer to Thermistor Test, this page; and Moisture Sensor Strip Circuit, page 3. - HARNESS/CONNECTION - MOISTURE SENSOR - THERMISTOR - ELECTRONIC CONTROL - MAY NEED TO CHANGE TIMER SETTING TO A MORE DRY SETTING For more details, see Troubleshooting section, page 7.
TIMER CONTINUOUSLY ADVANCES.	Refer to Timer Drawing, page 2; and Motor Strip Circuit, page 3. - HARNESS/CONNECTION - TIMER For more details, see Troubleshooting section, page 7.
WRINKLE SHIELD DOES NOT RUN.	Refer to Wrinkle Shield Switch (On/Off) Test, page 5.

IMPORTANT: Electrostatic (static electricity) discharge may cause damage to electronic control assemblies. See page 1 for details.

TROUBLESHOOTING

PROBLEM: Dryer Will Not Run

(Refer to Motor Strip Circuit, page 3; and Troubleshooting Guide, page 6.)

1. Unplug dryer or disconnect power.
2. Check connector pins in P2 connector of the electronic control to verify they are making good connections.
3. Check the Push to Start (PTS) switch continuity when pressed. It should show continuity while pushed in. If not, replace the PTS switch.
4. Perform Door Switch Test, page 5.
5. If the motor started but did not continue to run, and components checked in steps 2 through 4 were OK, replace the electronic control assembly.
6. If motor did not start and components checked in steps 2 through 4 were OK, replace the motor.

PROBLEM: Dryer Will Not Heat

(Refer to Heater Strip Circuit, page 3; and Troubleshooting Guide, page 6.)

1. Perform Supply Connections Test, page 4.
2. Perform Thermal Cut-Off Test, page 6.
3. Perform High Limit Thermostat Test, page 5.
4. Perform Thermal Fuse Test, page 6.
5. Perform Gas Valve Test, page 6.

PROBLEM: Dryer Heats During Air Only (No Heat) Cycle

(Refer to Heater Strip Circuit, page 3; and Troubleshooting Guide, page 6.)

1. Perform Temperature Switch Test, page 5.
2. Unplug dryer or disconnect power.
3. Check continuity of heater relay contacts. COM to NO should be open. If not, replace the heater relay.
4. With dryer fully assembled, plug in dryer or reconnect power.
5. Set to Air Only. If the dryer still heats:
 - Unplug dryer or disconnect power.
 - Replace the electronic control assembly.

PROBLEM: Dryer Won't Shut Off

(Refer to Motor and Moisture Sensor Strip Circuits, page 3; and Troubleshooting Guide, page 6.)

1. With the dryer fully assembled, set the timer to Off. If the dryer starts running as soon as it is plugged in:
 - Unplug dryer or disconnect power.
 - Replace the timer.
2. Set the following configuration:
 - Dryer - power cord plugged in
 - Door - must be closed
 - Temperature switch - Senseon High
 - Timer - Timed Drying for less than 10 minutes
3. If the dryer starts running before the Push to Start (PTS) switch is pressed:
 - Unplug dryer or disconnect power.
 - Replace the PTS switch.
 - If, after replacing the PTS switch, the dryer still starts before the PTS switch is pressed:
 - Unplug dryer or disconnect power.
 - Replace the motor relay.
4. If the dryer does not stop after the set time elapses:
 - Unplug dryer or disconnect power.
 - Check the motor relay. Continuity of relay should be open from COM to NO.
5. If the dryer will not terminate its cycle when set to AccuDry Sensor Drying:
 - Unplug dryer or disconnect power.
 - Check the moisture sensor.
 - If there is continuity to Ground for Yellow/Red (Y/R) wire with no load, look for a short in the sensor or Y/R wire. Verify harness connections both at the sensor and the electronic control.
 - If the sensor and Y/R wire are good, replace the electronic control assembly.

PROBLEM: Dryer Shuts Off Before Clothes Are Dry

(Refer to Moisture Sensor Strip Circuit, page 3; Thermistor Test, page 6; and Troubleshooting Guide, page 6.)

1. Test the moisture sensor by following the procedure outlined in the Diagnostic Test, page 1. If the moisture sensor fails the Diagnostic Test (does not produce a beep sound):
 - Unplug dryer or disconnect power.
 - Check the moisture sensor.
 - If there is continuity to Ground for Yellow/Red (Y/R) wire with no load, look for a short in the Sensor or Y/R wire. Verify harness connections both at the sensor and the electronic control.
 - If the Sensor and Y/R wire are good, replace the electronic control assembly.
2. If Diagnostic Test is passed, verify thermistor by performing test procedures outlined in Thermistor Test, page 6.
3. If problem persists after replacing moisture sensor and thermistor:
 - Unplug dryer or disconnect power.
 - Replace the electronic control assembly.

PROBLEM: Timer Continuously Advances

(Refer to Timer Drawing, page 2; Motor Strip Circuit, page 3; and Troubleshooting Guide, page 6.)

1. Unplug dryer or disconnect power.
2. Verify the Blue wire and the Black L1 wires are in the correct positions. See timer illustration on page 2.
3. Test the timer by following the procedure outlined in the Diagnostic Test, page 1.
4. If the timer continues to advance past Off, then replace the timer.

MANUFACTURED UNDER ONE OR
MORE OF THE FOLLOWING U.S. PATENTS:

4,669,200	4,899,464	5,809,828	6604298
4,700,495	4,908,959	6,020,698	D314,261
4,754,556	4,989,347	6,047,486	D314,262
4,840,285	5,066,050	6,199,300	D457,991
4,865,366	5,560,120	6,446,357	D457,992