

⚠ WARNING



Electrical Shock Hazard
 Disconnect power before servicing.
 Replace all parts and panels before operating.
 Failure to do so can result in death or electrical shock.

IMPORTANT

Electrostatic Discharge Sensitive Electronics (ESD)

ESD problems are present everywhere. ESD may damage or weaken the machine control electronics. The new control assembly may appear to work well after repair is finished, but failure may occur at a later date due to ESD stress.

- Use an anti-static wrist strap. Connect wrist strap to green ground connection point or unpainted metal in the appliance -OR- Touch your finger repeatedly to a green ground connection point or unpainted metal in the appliance.
- Before removing the part from its package, touch the anti-static bag to a green ground connection point or unpainted metal in the appliance.
- Avoid touching electronic parts or terminal contacts; handle machine control electronics by edges only.
- When repackaging failed machine control electronics in anti-static bag, observe above instructions.

DIAGNOSTIC GUIDE

Before servicing, check the following:

- Make sure there is power at the wall outlet.
- Has a household fuse blown or circuit breaker tripped? Was a regular fuse used? Use a time-delay fuse.
- Is dryer vent properly installed and clear of lint or obstructions?
- All tests/checks should be made with a VOM (volt-ohm-milliammeter) or DVM (digital-voltmeter) having a sensitivity of 20,000 Ω per volt DC or greater.
- Check all connections before replacing components. Look for broken or loose wires, failed terminals, or wires not pressed into connectors far enough.
- A potential cause of a control not functioning is corrosion on connections. Observe connections and check for continuity with an ohmmeter.
- Connectors: Look at top of connector. Check for broken or loose wires. Check for wires not

pressed into connector far enough to engage metal barbs.

- Resistance checks must be made with dryer unplugged or power disconnected.

DIAGNOSTIC TESTS

These tests allow service personnel to test and verify all inputs to the machine control electronics. You may want to do a quick and overall checkup of the dryer with these tests before going to specific troubleshooting tests.

ACTIVATING THE DIAGNOSTIC TEST MODE

1. Be sure the dryer is in standby mode (plugged in with all indicators off, or with only the Done indicator on).
2. Select any one button (except Pause/Cancel and Controls Lock/Unlock) and follow the steps below, using the same button (remember the button):

Press/hold 2 → for 2 seconds Release → for 2 seconds Press/hold 2 → for 2 seconds Release → for 2 seconds Press/hold 2 → for 2 seconds

3. If this test mode has been entered successfully, all indicators on the console are illuminated for 5 seconds with *B:BB* showing in the Estimated Time Remaining three-digit display. If there are no saved fault codes or active fault codes, all indicators on the console will momentarily turn off, then stay on with *B:BB* displayed. Continue with diagnostics.
4. If entry into Diagnostic Test Mode is unsuccessful, choose a different button (except Pause Cancel and Controls Lock/Unlock) and repeat step 2.
 - If no indicators come on after repeating step 2 using a different button, go to TEST #1, page 4.

DIAGNOSTIC: Active Fault Codes

If there is an active fault code, it will be flashing in the display. Review the Display Fault/Error Codes table, page 3, for the recommended procedure.

If there is no active fault code, *B:BB* will be displayed and all of the indicator lights will be turned on.

DIAGNOSTIC: Saved Fault Codes

If there are saved fault codes, the most recent fault code will show "F:" and flash "XX" where XX is the fault code.

Press and release the same button used to activate diagnostics	→ beep tone	→ Second most recent fault code is displayed.
Repeat	→ beep tone	→ Third most recent fault code is displayed.
Repeat	→ beep tone	→ Fourth most recent fault code is displayed.
Repeat	→	All indicators momentarily turn off, then stay on.

DIAGNOSTIC: Console Buttons and Indicators

Pressing buttons and rotating the cycle selector will turn off the corresponding indicator and sound a beep as shown in figure 1, page 2.

- ✓ Pressing (more time) will toggle the left digit and colon on the display while sounding a beep.
- ✓ Pressing (less time) will toggle the right two digits on the display while sounding a beep.
- ✓ Electric Models Only: Pressing the Wrinkle Shield button will activate the Inlet Air Flow Test. See DIAGNOSTIC: Displaying Inlet Air Flow, page 2.
- ✓ Pressing the Cycle Signal button will activate the Line Voltage Test. See DIAGNOSTIC: Displaying Line Voltage, page 2.

→ If indicators fail to come on and beep after pressing buttons and rotating the cycle selector, go to TEST #6, page 8.

DIAGNOSTIC: Door Switch

Opening the door should cause a beep and an alphanumeric number (such as *P:3E*) to be displayed. Closing the door should cause a beep and *B:BB* to be displayed.

→ If opening the door fails to cause a beep and a number and letter to be displayed, go to TEST #7, page 9.

NOTE: Opening the door while in Diagnostic Test Mode may not activate the drum light. The light will come on when Start is pressed, or upon opening the door after the Diagnostic Test Mode has been canceled.

DIAGNOSTIC: Moisture Sensor

Open the door and locate two metal strips on the inside of the dryer. Using a wet cloth or one finger, jointly touch both strips.

→ If a continuous beep tone is heard and an alphanumeric number is displayed on the console, the sensor is OK.

→ If a continuous beep tone is not heard, or if a continuous beep tone is heard before touching both moisture strips, go to TEST #5, page 8.

DIAGNOSTIC: Motor, Heater, and Console ID

Close the door. Press the Start button. The motor and heater will turn on. Continuing to press the Start button will display the project codes and software revisions. These codes are not relevant to the service of the dryer and can be ignored.

NOTE: The console buttons only control the indicator lights in Diagnostic Test Mode. When the buttons are pressed, the corresponding features will not be activated.

→ If the motor does not turn on, go to TEST #3, page 5.

→ If no heat is detected, go to TEST #4, page 6.

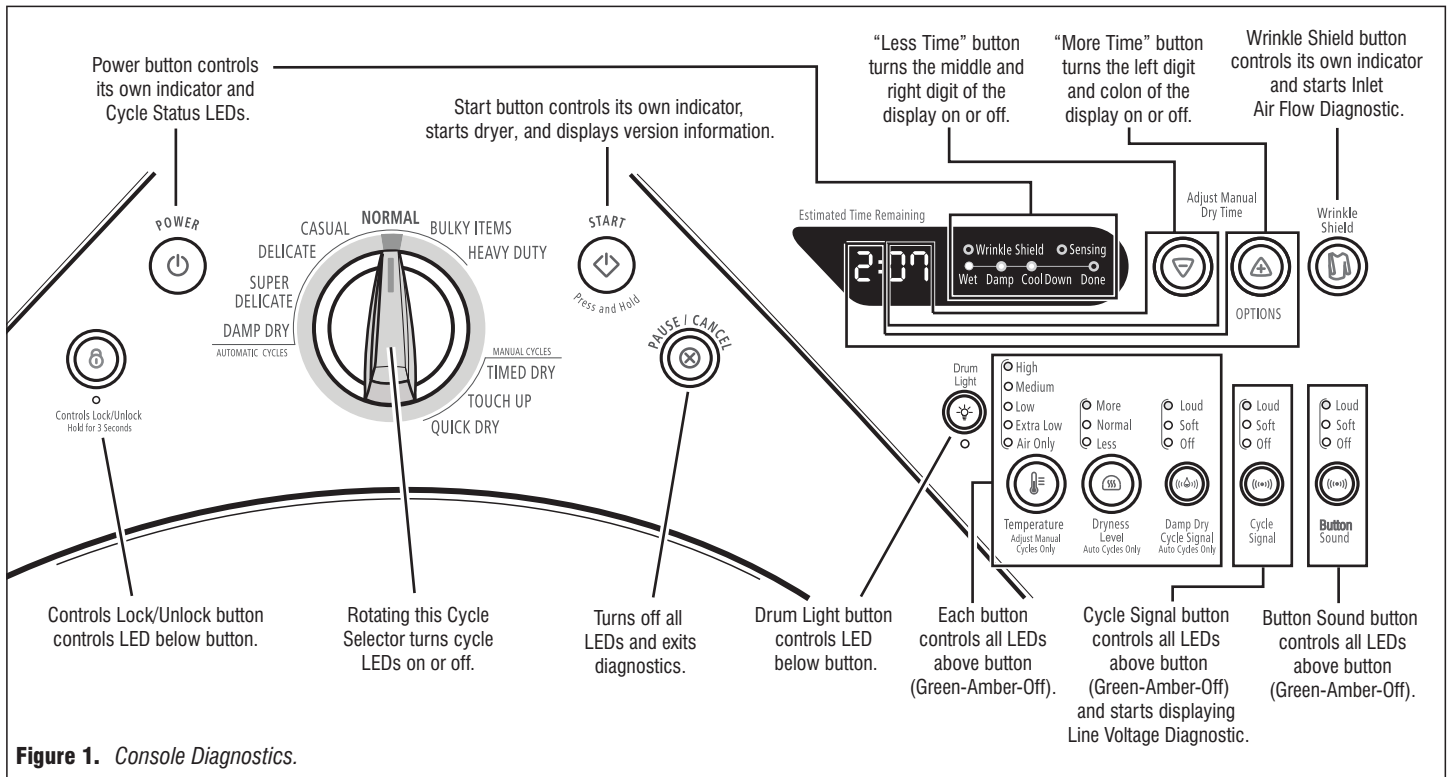

Figure 1. Console Diagnostics.

DIAGNOSTIC: Displaying Inlet Air Flow (Electric Models Only)

Used to display the air flow value at the inlet of the heater box being measured by the machine control.

After entering the Diagnostic Test Mode, waiting for the 5 second delay, and cycling through any saved fault codes, press the Wrinkle Shield button to activate air flow detection. A 30 or 50 second countdown timer will start and the dryer will turn on.

→ If the dryer is cold, the countdown will start at 50 seconds.

NOTE: If the dryer is extremely cold (less than 40°F [4.4°C]), the air flow may not be detected properly, and "--" will be displayed.

→ If the dryer is hot, the countdown timer will start at 30 seconds (cool down period), followed by an additional 50 second countdown.

A Dryness Level modifier LED will also be illuminated to indicate the air flow range corresponding to the number displayed.

- The More LED will be illuminated for air flow readings above 40 cfm.
 - The Normal LED will be illuminated for air flow readings between 29 and 40 cfm.
 - The Less LED will be illuminated for air flow readings less than 29 cfm.
- If air flow value is low (Less LED is lit), check to make sure the lint screen is clean, the door seal is in place, and the vent is not obstructed.

DIAGNOSTIC: Displaying Line Voltage

Used to display the line voltage currently being measured by the machine control:

After entering the Diagnostic Test Mode, waiting for the 5 second delay, and cycling through any saved fault codes, press the Cycle Signal button. The voltage value will be displayed.

→ If the line voltage is not seen on L2, the display will flash L2. Go to TEST #1, page 4.

DEACTIVATING THE DIAGNOSTIC TEST MODE

Press the Pause/Cancel button to exit diagnostics.

ACTIVATING THE MANUAL LOAD TEST

1. Be sure the dryer is in standby mode (plugged in with all indicators off, or with only the Done indicator on).
2. Select any one button (except Pause/Cancel and Controls Lock/Unlock) and follow the steps below, using the same button (remember the button):
 - a. Press/hold 2 seconds
 - b. Release for 2 seconds
 - c. Press/hold 2 seconds
 - d. Release for 2 seconds
 - e. Press/hold 2 seconds
 - f. Release for 2 seconds
 - g. Press/hold 2 seconds

The motor starts right away, the "Sensing" Status LED comes on, and "0" (zero) is displayed (this step starts the Manual Load sequence):

1. Motor turns on. → "Sensing" Status LED turns on. → 0:00 is displayed.

Now press any key (except Pause/Cancel and Controls Lock/Unlock) and the control will advance through each step of the following sequence:

2. Motor + heater. → "Damp" Status LED turns on. → 0:02 is displayed.
3. Motor + heater + drum light. → "Cool Down" Status LED turns on. → 0:03 is displayed.
4. All loads turn off. → "Done" Status LED turns on. → 0:04 is displayed.

DEACTIVATING THE MANUAL LOAD TEST

Press the Pause/Cancel button to exit this mode.

DISPLAY FAULT/ERROR CODES

The fault codes below would be indicated when attempting to start a drying cycle, or after activating the Diagnostic Test Mode.

Display	Description	Explanation / Recommended Procedure
PF	Power Failure	PF flashes to indicate that a power failure occurred while the dryer was running. ■ Press Start to continue the cycle, or press Pause/Cancel to clear the display.
L2	Low Line Voltage	L2 flashes if low line voltage (less than 30 V) is detected at installation. ■ Check to see if a household fuse has blown or a circuit breaker has tripped. ■ Confirm the power cord is properly installed and plugged into the power outlet. ■ Check the relay connections on the machine control electronics. ■ Gas Models Only: Check the P14 connection on the machine control electronics.
RF	Low Air Flow Condition	AF flashes if low inlet air flow is detected at install. ■ Check to see if the vent run from the dryer to the wall is crushed. ■ Perform steps under DIAGNOSTIC: Displaying Inlet Air Flow, page 2.
F-01	Primary Control Failure	F:01 flashes when there is a primary control failure. ■ Replace the machine control electronics. See Accessing & Removing the Electronic Assemblies, page 9.
F-02	Keypad/ User Interface Failure	F:02 flashes when there is a stuck button or user interface mismatch. This fault code appears ONLY when in the Diagnostic Test Mode. ■ See TEST #6, page 8.
F-20	Heater Failure	F:20 flashes if no voltage is detected at the heater relay. This fault code appears ONLY when in the Diagnostic Test Mode. ■ Check that the wires are plugged in on the heater assembly and at the relay on the electronic control.
F-22	Outlet Thermistor Open	F:22 flashes if the outlet thermistor is open. ■ See TEST #4a, page 7.
F-23	Outlet Thermistor Shorted	F:23 flashes if the outlet thermistor has shorted. ■ See TEST #4a, page 7.
F-24	Inlet Thermistor Open	F:24 flashes if the inlet thermistor is open. This fault code appears ONLY when in the Diagnostic Test Mode. ■ See TEST #4a, page 7.
F-25	Inlet Thermistor Shorted	F:25 flashes if the inlet thermistor is shorted. This fault code appears ONLY when in the Diagnostic Test Mode. ■ See TEST #4a, page 7.
F-26	Motor Drive System Failure	F:26 flashes if there is a motor drive system failure. ■ See TEST #3, page 5.
F-28	Moisture Sensor Open	F:28 flashes if the moisture sensor strip is open. This fault code appears ONLY when in the Diagnostic Test Mode. ■ See TEST #5, page 8.
F-29	Moisture Sensor Shorted	F:29 flashes if the moisture sensor strip has shorted. This fault code appears ONLY when in the Diagnostic Test Mode. ■ See TEST #5, page 8.

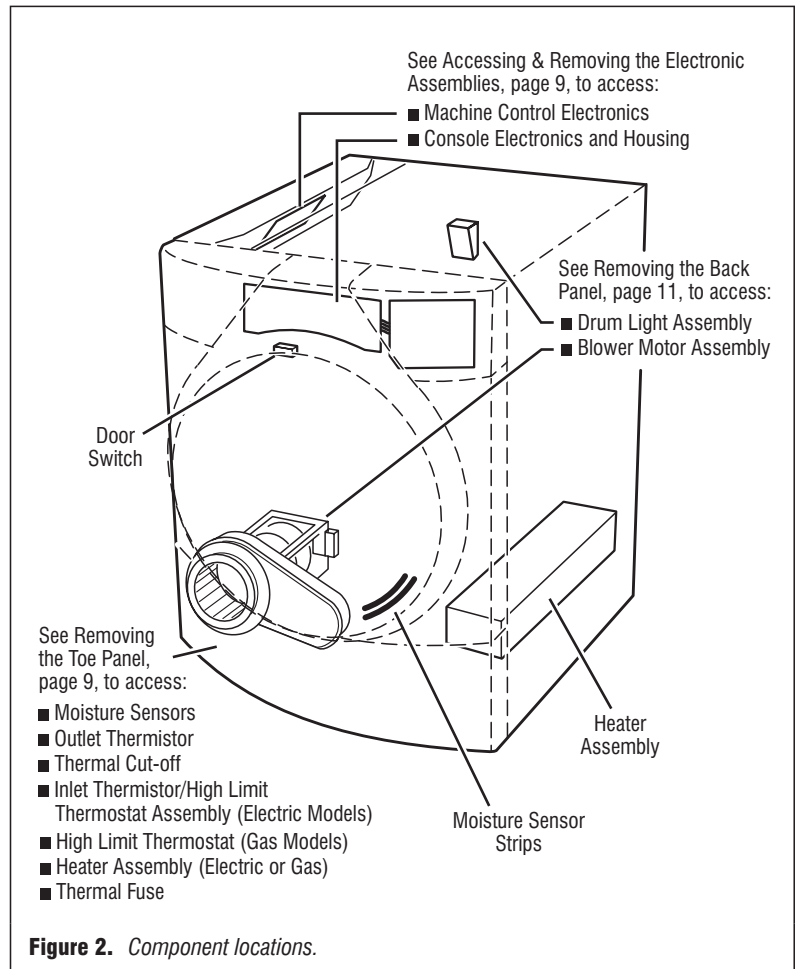

Figure 2. Component locations.

Display	Description	Explanation / Recommended Procedure
F-30	Restricted Air Flow Condition	F:30 flashes if a restricted air flow condition exists. This fault code appears ONLY when in the Diagnostic Test Mode. ■ Check to make sure the lint screen is clean, the door seal is in place, and the vent is not obstructed. ■ See DIAGNOSTIC: Displaying Inlet Air Flow, page 2.
F-31	L2 Line Voltage Error	F:31 flashes if a low voltage condition (less than 30 V) has been detected. This fault code appears ONLY when in the Diagnostic Test Mode. ■ Check to see if a household fuse has blown or a circuit breaker has tripped. ■ Confirm the power cord is properly installed and plugged into the power outlet. ■ Check the relay connections on the electronic control.
F-70 F-71	No Communication Between Electronic Assemblies	F:70 / F:71 flashes when there is no communication between the machine control and the console electronics. ■ Check console electronics harness connections to the machine control. ■ Replace the machine control electronics. See Accessing & Removing the Electronic Assemblies, page 9.
F-72 through F-78	Console Electronics Failure	F:72 through F:78 flashes when there is a console electronics failure. ■ Replace the console electronics. See Accessing & Removing the Electronic Assemblies, page 9.

TROUBLESHOOTING GUIDE

Some tests will require accessing components. See figure 2, page 3, for component locations.

Problem	Possible Cause / Test
NOTE: Possible Cause/Tests MUST be performed in the sequence shown for each problem.	
Won't power up. (No response when buttons are pressed.)	
<ol style="list-style-type: none"> 1. Supply connections. See TEST #1, at right. 2. Check harness connections. 3. Console electronics and housing assembly. See TEST #6, page 8. 	
Won't start cycle when Start button is pressed.	
<ol style="list-style-type: none"> 1. If number display flashes, check to be sure the door is completely shut, and press and hold down Start for about 1 second. 2. See TEST #3, page 5. 3. See TEST #7, page 9. 	
Won't shut off when expected.	
<ol style="list-style-type: none"> 1. Check Pause/Cancel button. 2. Console electronics and housing assembly. See TEST #6, page 8. 3. Moisture sensor. See TEST #5, page 8. 	
Control won't accept selections.	
Console electronics and housing assembly. See TEST #6, page 8.	
Won't heat.	
<ol style="list-style-type: none"> 1. Heater. See TEST #4, page 6. 2. Check harness connections. 3. See DIAGNOSTIC: Displaying Line Voltage, page 2. 4. Check installation. 	
Heats in air cycle.	
Heater. See TEST #4, page 6.	
Shuts off before clothes are dry.	
<ol style="list-style-type: none"> 1. Check the dryness setting for auto cycles. 2. Check for full lint screen. 3. See DIAGNOSTIC: Displaying Inlet Air Flow, page 2. 4. Check for clogged vent. 5. Moisture sensor. See TEST #5, page 8. 6. Dryness level adjust. See TEST #5a, page 8. 	
Pushing Power button causes dryer to beep, but no indicators light.	
<ol style="list-style-type: none"> 1. Check console electronics harness connections to the machine control. 2. Replace machine control electronics. See Accessing & Removing the Electronic Assemblies, page 9. 	

TROUBLESHOOTING TESTS

NOTE: These checks are done with the dryer unplugged or disconnected from power.

TEST #1 Supply Connections

This test assumes that proper voltage is present at the outlet, and visual inspection indicates that the power cord is securely fastened to the terminal block (electric dryer) or wire harness connection (gas dryer).

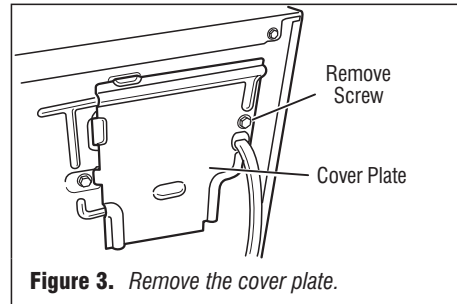

Figure 3. Remove the cover plate.

ELECTRIC DRYER:

1. Unplug dryer or disconnect power.
2. Remove the cover plate from the top right corner of the back of the dryer. See figure 3.
3. With an ohmmeter, check for continuity between the neutral (N) terminal of the plug and the center contact on the terminal block. See figure 4.
 - If there is no continuity, replace the power cord and test the dryer.
 - If there is continuity, go to step 4.
4. In a similar way, check which terminal of the plug is connected to the left-most contact on the terminal block and make a note of it. This will be L1 (black wire) in the wiring diagram. See figure 4.

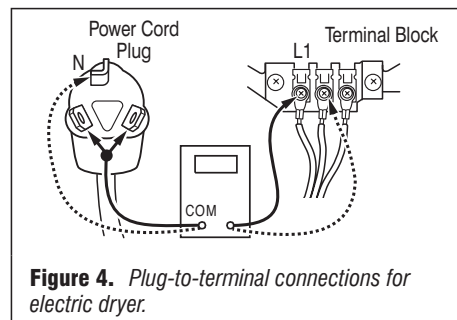

Figure 4. Plug-to-terminal connections for electric dryer.

- When this is found, go to step 5.
 - If neither of the plug terminals have continuity with the left-most contact of the terminal block, replace the power cord and test the dryer.
5. Access the machine control electronics without disconnecting any wiring to the control board. See Accessing & Removing the Electronic Assemblies, page 9.

6. With an ohmmeter, check for continuity between the L1 terminal of the plug (found in step 4) and P9-2 (black wire) on the machine control board. See figure 17, page 10.
 - If there is continuity, go to step 7.
 - If there is no continuity, check that wires to the terminal block are mechanically secure. If so, replace the main wire harness and test the dryer.
7. Check for continuity between the neutral (N) terminal of the plug and P8-3 (white wire) on the machine control board.
 - If there is continuity, go to step 8.
 - If there is no continuity and the mechanical connections of the wire are secure, replace the main wire harness.
8. Visually check that the P5 connector is inserted all the way into the machine control electronics.
9. Visually check that the console electronics and housing assembly is properly inserted into the front console.
10. If both visual checks pass, replace the console electronics and housing assembly.
11. Plug in dryer or reconnect power.
12. Perform steps under DIAGNOSTIC: Console Buttons and Indicators, page 1, to verify repair.
13. If indicators still do not light, perform TEST #2, page 5.

GAS DRYER:

1. Unplug dryer or disconnect power.
2. Remove the cover plate from the top right corner of the back of the dryer. See figure 3.
3. Check that the power cord is firmly connected to the dryer's wire harness. See figure 5.

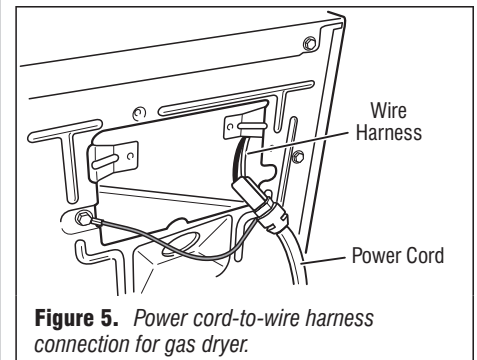

Figure 5. Power cord-to-wire harness connection for gas dryer.

4. Access the machine control electronics without disconnecting any wiring to the control board. See figure 16, page 9.
5. With an ohmmeter, check for continuity between the neutral (N) terminal of the plug and P8-3 (white wire) on the machine control board. The left-hand side of figure 6 shows the position of the neutral terminal (N) on the power cord plug. Also see figure 17, page 10.
 - If there is continuity, go to step 6.

→ If there is no continuity, disconnect the white wire of the harness from the power cord at the location illustrated in figure 5. Test the continuity of the power cord neutral wire as illustrated in figure 6. If an open circuit is found, replace the power cord. Otherwise, go to step 6.

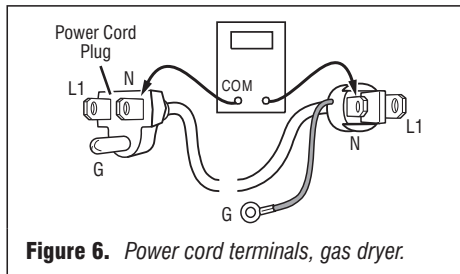

Figure 6. Power cord terminals, gas dryer.

6. In a similar way, check the continuity between the L1 terminal of the plug and P9-2 (black wire) on the control board.
 - If there is continuity, go to step 8.
 - If there is no continuity, check the continuity of the power cord in a similar way to that illustrated in figure 6, but for power cord's L1 wire.
 - If an open circuit is found, replace the power cord. Otherwise, replace the main harness.
7. Visually check that the P5 connector is inserted all the way into the machine control electronics.
8. Visually check that the console electronics and housing assembly is properly inserted into the front console.
9. If both visual checks pass, replace the console electronics and housing assembly.
10. Plug in dryer or reconnect power.
11. Perform steps under DIAGNOSTIC: Console Buttons and Indicators, page 1, to verify repair.
12. If indicators still do not light, perform TEST #2.

TEST #2 Machine Control Power Check

This test is used to determine if power is present at the machine control electronics. This test assumes that TEST #1 has been completed.

NOTE: The drum light is controlled by the machine control on all models.

1. Plug in dryer or reconnect power.
2. Open the door.
 - If the drum light illuminates, then power is present at the machine control. Go to step 3.
 - If the drum light fails to illuminate, the problem may be as simple as a bad bulb. Replace bulb with a working bulb. If drum light still fails to illuminate, continue with step 3.
3. Unplug dryer or disconnect power.

4. Replace the machine control electronics.
5. Plug in dryer or reconnect power.
6. Perform steps under DIAGNOSTIC: Console Buttons and Indicators, page 1, to verify repair.

TEST #3 Motor Circuit

This test will check the wiring to the motor and the motor itself. The following items are part of this motor system:

Part of Motor System	Electric Dryer	Gas Dryer
Harness/connection	✓	✓
Thermal fuse	✓	no
Belt/belt switch	✓	✓
Drive motor	✓	✓
Centrifugal switch	✓	✓
Door switch	✓	✓
Machine control electronics. See ESD information, page 1.	✓	✓

1. Unplug dryer or disconnect power.
2. Access the machine control electronics and measure the resistance across P8-4 and P9-1. See Accessing & Removing the Electronic Assemblies, page 9.
 - If resistance across P8-4 and P9-1 is in the range of 1 to 6 Ω, replace the machine control electronics.
 - Otherwise, go to step 3.
3. Check the wiring and components in the path between these measurement points by referring to the appropriate wiring diagram (gas or electric) on page 12.

ELECTRIC DRYER ONLY: Check the thermal fuse. See TEST #4b, page 7.

ALL DRYERS: Continue with step 4 below to test the remaining components in the motor circuit.

4. Check the belt switch and drive motor. Access the belt switch and drive motor by removing the back panel. See Removing the Back Panel, page 11. Slowly remove the drum belt from the spring-loaded belt switch pulley, gently letting the belt switch pulley down. See figure 7.

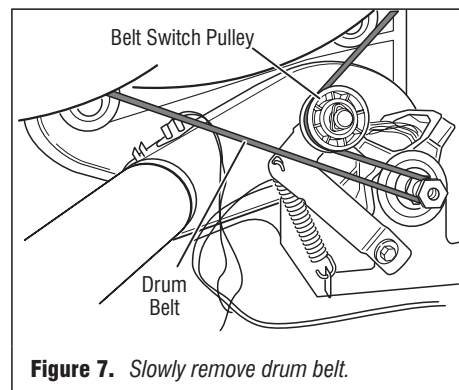

Figure 7. Slowly remove drum belt.

5. Remove the white connector from the drive motor switch. See figure 8.

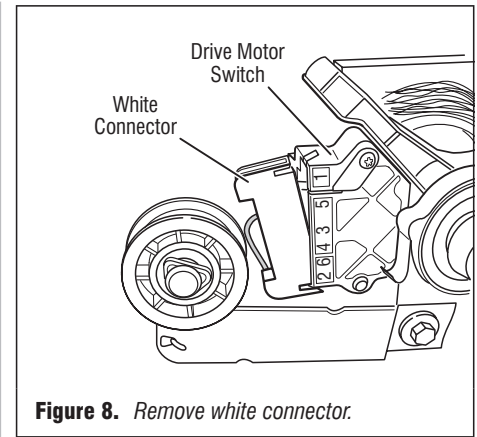

Figure 8. Remove white connector.

6. Remove the bare copper wire terminal from pin 5 of black drive motor switch. See figure 9.

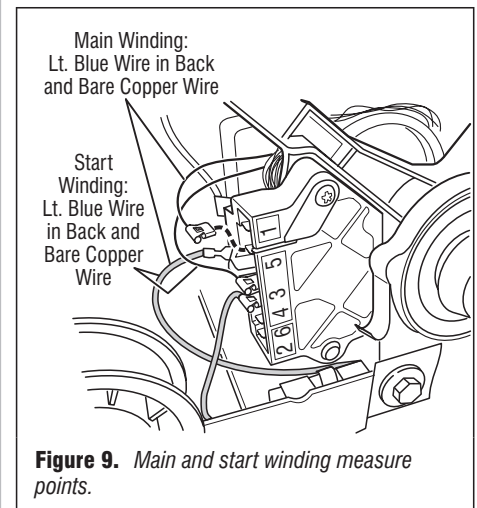

Figure 9. Main and start winding measure points.

7. Using figure 9, check for the resistance values of the motor's Main and Start winding coils as shown in the following table.

NOTE: Main and Start winding coils must be checked at the motor.

Winding	Resistance Ω	Contact Points of Measurement
MAIN	3.3-3.6	Lt. blue wire in back at pin 4 and bare copper wire terminal removed from pin 5 of black drive motor switch
START	2.7-3.0	Lt. blue wire in back at pin 4 and bare copper wire terminal on pin 3 of black drive motor switch

- If the resistance at the motor is correct, there is an open circuit between the motor and machine control electronics. Check for failed belt switch.
- If the Start winding resistance is much greater than 3 Ω, replace the motor.

8. Check the belt switch by measuring resistance between the two light blue wires, as shown in figure 10, page 6, while pushing up the belt switch pulley.

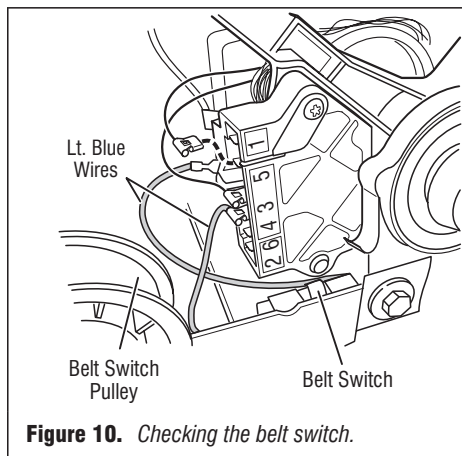

Figure 10. Checking the belt switch.

- If the resistance reading goes from infinity to a few ohms as pulley arm closes the switch, belt switch is OK. If not, replace the belt switch.
- If belt switch is OK and there is still an open circuit, check and repair the wiring harness.

9. Door Switch problems can be uncovered by following procedure under DIAGNOSTIC: Door Switch, page 1; however, if this was not done, the following can be done without applying power to the dryer. Connect an ohmmeter across P8-3 (neutral, white wire) and P8-4 (door, tan wire).
 - With the door properly closed, the ohmmeter should indicate a closed circuit (0–2 Ω).
 - If not, replace the door switch assembly.

TEST #4 Heater

This test is performed when either of the following situations occur:

- ✓ Dryer does not heat
- ✓ Heat will not shut off

This test checks the components making up the heating circuit. The following items are part of this system:

Part of Heating System	Electric Dryer	Gas Dryer
Harness/connection	✓	✓
Heater relay	✓	✓
Thermal cut-off	✓	✓
Thermal fuse	no	✓
Inlet thermistor/high limit thermostat assembly	✓	no
High limit thermostat	no	✓
Heat element assembly	✓	no
Gas burner assembly	no	✓
Centrifugal switch	✓	✓
Outlet thermistor	✓	✓
Machine control electronics. See ESD information, page 1.	✓	✓
Console electronics and housing assembly	✓	✓
Gas supply	no	✓

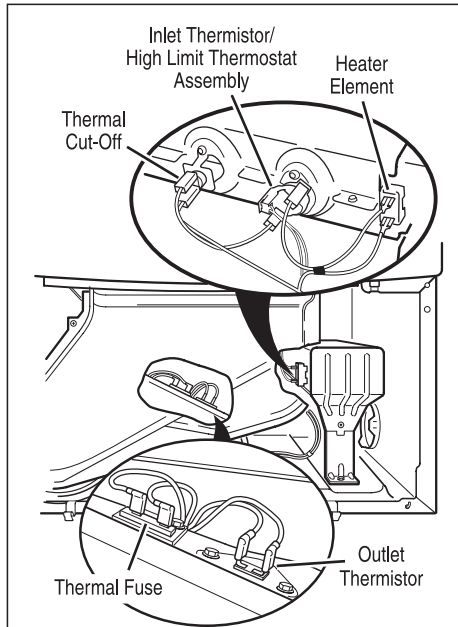

Electric Dryer

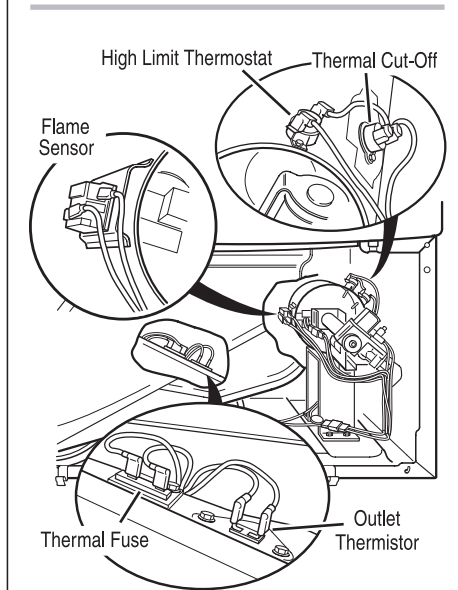

Gas Dryer

Figure 11. Thermal Components, viewed from front.

Dryer does not heat:

Locate the components using figure 11.

ELECTRIC DRYER:

1. Unplug dryer or disconnect power.
2. Remove the toe panel to access the thermal components. See Removing the Toe Panel, page 9.
3. Using an ohmmeter and referring to the wiring diagram, measure the resistance from the red wire terminal at the thermal cut-off to the red wire terminal at the heater.
 - If the resistance is about 10 Ω, go to step 5.
 - If an open circuit is detected, go to step 4.

4. Visually check the wire connections to the thermal cut-off, high limit thermostat, and heater. If connections look good, check for continuity across each of these components.

- Replace the heater if it is electrically open.
- Replace both the thermal cut-off and inlet thermistor/high limit thermostat assembly if either the thermal cut-off or the high limit thermostat is electrically open.

5. If no open circuit is detected, remove the P4 connector, then measure the resistance between P4-3 (red wire) and P4-6 (red wire) at the connector. See figure 17, page 10, for connector location; and Accessing & Removing the Electronic Assemblies, page 9.

- If 5–15 kΩ are measured, replace the machine control electronics.
- If the resistance is less than 1 kΩ, replace the outlet thermistor.

GAS DRYER:

1. Unplug dryer or disconnect power.
2. Remove the toe panel to access the thermal components. See Removing the Toe Panel, page 9.
3. Perform TEST #4b, page 7. If the thermal fuse is OK, go to step 4.
4. Perform TEST #4c, page 7. If the thermal cut-off is OK, go to step 5.
5. Locate the high limit thermostat. See figure 11. Measure the continuity through it by connecting the meter probes on the red wire and black wire terminals.
 - If there is an open circuit, replace the high limit thermostat and the thermal cut-off.
 - Otherwise, go to step 6.
6. Perform TEST #4d, page 8. If this is OK, replace the machine control electronics.

Heat will not shut off:

1. Unplug dryer or disconnect power.
2. Access the machine control electronics. See figure 17, page 10, for connector location; and Accessing & Removing the Electronic Assemblies, page 9.

ELECTRIC DRYER: Remove the P4 connector, then measure the resistance between P4-3 (red wire) and P4-6 (red wire) at the connector.

GAS DRYER: Remove the P14 connector, then measure the resistance between P14-3 (red-white wire) and P14-6 (red-white wire) at the connector.

ALL DRYERS:

- If 5–15 kΩ are measured, replace the machine control electronics.
- If the resistance is greater than 20 kΩ, replace the outlet thermistor.

TEST #4a Thermistors

Outlet Thermistor

The machine control electronics monitors the exhaust temperature using the outlet thermistor, and cycles the heater relay on and off to maintain the desired temperature.

Begin with an empty dryer and a clean lint screen.

1. Plug in dryer or reconnect power.
2. Start the Timed Dry cycle.
3. If after 60 seconds, *F-22* or *F-23* flashes in the display and the dryer shuts off, the thermistor or wire harness is either open or shorted.

→ Unplug dryer or disconnect power.

→ Check wire connections at the machine control electronics and thermistor. See Accessing & Removing the Electronic Assemblies, page 9, and for thermistor location, see figure 11, page 6.

→ If wire connections are OK, check the outlet thermistor resistance per step 5.

4. If *F-22* or *F-23* does not flash in the display, the connections to the thermistor are good. Therefore, check the exhaust temperature value at any or all of the temperature levels in question, using the Timed Dry cycle, and the following process:

Hold a glass bulb thermometer capable of reading from 90° to 180°F (32° to 82°C) in the center of the exhaust outlet. The correct exhaust temperatures are as follows:

EXHAUST TEMPERATURES		
TEMPERATURE SETTING	HEAT TURNS OFF* °F (°C)	HEAT TURNS ON °F (°C)
High	155° ± 5° (68° ± 3°)	10–15° (6–8°) below the heat turn off temperature
Medium	140° ± 5° (60° ± 3°)	
Low	125° ± 5° (52° ± 3°)	
Extra Low	105° ± 5° (41° ± 3°)	

* The measured overshoot using the glass bulb thermometer in the exhaust outlet can be 30°F (17°C) higher.

5. If the exhaust temperature is not within specified limits, or you have come here from step 3, perform the following:

NOTE: All thermistor resistance measurements must be made while dryer is unplugged or disconnected from power.

ELECTRIC DRYER: Remove the P4 connector, then measure the resistance between P4-3 (red wire) and P4-6 (red wire) at the connector.

→ If the resistance is OK, check P4-3 and P4-6 to dryer ground.

→ If resistance is greater than 0 (zero), replace wiring harness.

GAS DRYER: Remove the P14 connector, then measure the resistance between P14-3 (red-white wire) and P14-6 (red-white wire) at the connector.

→ If the resistance is OK, check P14-3 and P14-6 to dryer ground.

→ If resistance is greater than 0 (zero), replace wiring harness.

ALL DRYERS:

The following table gives temperatures and their associated resistance values.

OUTLET THERMISTOR RESISTANCE			
TEMP. °F (°C)	RES. RANGE kΩ	TEMP. °F (°C)	RES. RANGE kΩ
50° (10°)	19.0–22.0	80° (27°)	8.5–10.5
60° (16°)	14.8–16.8	90° (32°)	6.8–8.8
70° (21°)	11.5–13.5	100° (38°)	5.0–7.0

→ If the thermistor resistance does not agree with table, replace the outlet thermistor.

→ If the thermistor resistance checks agree with the measurements in the table, replace the machine control electronics.

Inlet Thermistor, Electric Dryer

The machine control electronics monitors the inlet temperature using an inlet thermistor that is part of the high limit thermostat assembly.

1. Activate the Diagnostic Test Mode. See procedure on page 1.

2. If *F-24* or *F-25* is a displayed error in the Diagnostic Test Mode, the inlet thermistor or wire harness is either open or shorted.

→ Unplug dryer or disconnect power.

→ Check wire connections at the machine control electronics and inlet thermistor. See Accessing & Removing the Electronic Assemblies, page 9, and for inlet thermistor location, see figure 11, page 6.

→ If wire connections are good, remove the wires from the inlet thermistor/high limit thermostat assembly and replace the assembly.

→ Plug in dryer or reconnect power.

3. If *F-24* or *F-25* is not an error that is displayed in the Diagnostic Test Mode, the connections to the thermistor are good. Therefore, check the thermistor's resistance value, using the following process:

→ Unplug dryer or disconnect power.

→ Access the heater assembly. See figure 2, page 3; and Removing the Toe Panel, page 9.

→ Hold a glass bulb thermometer capable of reading from 68° to 176°F (20° to 80°C) in the heater assembly.

→ Check the resistance of the inlet thermistor. See figure 11, page 6, for location.

The following table shows the resistance values that should be observed for the various temperatures at the heater assembly.

INLET THERMISTOR RESISTANCE			
TEMP. °F (°C)	RES. RANGE kΩ	TEMP. °F (°C)	RES. RANGE kΩ
68° (20°)	61.2–63.7	131° (55°)	14.6–15.3
77° (25°)	49.0–51.0	140° (60°)	12.1–12.8
86° (30°)	39.5–41.1	149° (65°)	10.2–10.7
95° (35°)	32.0–33.3	158° (70°)	8.5–9.0
104° (40°)	26.1–27.2	167° (75°)	7.2–7.6
113° (45°)	21.4–22.3	176° (80°)	6.1–6.5
122° (50°)	17.6–18.5		

→ If the thermistor resistance does not agree with the measurements in the table, replace the inlet thermistor/high limit thermostat assembly.

→ If the thermistor resistance agrees with the measurements in the table, replace the machine control electronics.

TEST #4b Thermal Fuse

ELECTRIC DRYER: The thermal fuse is wired in series with the dryer drive motor.

GAS DRYER: The thermal fuse is wired in series with the dryer gas valve.

ALL DRYERS:

1. Unplug dryer or disconnect power.

2. Access the thermal fuse by first removing the toe panel. See Removing the Toe Panel, page 9; and for thermal fuse location, see figure 11, page 6.

3. Using an ohmmeter, check the continuity across the thermal fuse.

→ If the ohmmeter indicates an open circuit, replace the failed thermal fuse.

TEST #4c Thermal Cut-Off

If the dryer does not produce heat, check the status of the thermal cut-off.

1. Unplug dryer or disconnect power.

2. Access the thermal cut-off by first removing the toe panel. See Removing the Toe Panel, page 9.

3. Using an ohmmeter, check the continuity across the thermal cut-off. See figure 11, page 6, for location.

4. If the ohmmeter indicates an open circuit, perform the following:

ELECTRIC DRYER: Replace the failed thermal cut-off and inlet thermistor/high limit thermostat assembly. In addition, check for blocked or improper exhaust system, or failed heat element.

GAS DRYER: Replace the failed thermal cut-off and high limit thermostat. In addition, check for blocked or improper exhaust system.

TEST #4d Gas Valve, Gas Dryer

1. Unplug dryer or disconnect power.
2. Access the gas valve by removing the toe panel. See Removing the Toe Panel, page 9.
3. Use an ohmmeter to determine if a gas valve coil has failed. Remove harness plugs. Measure resistance across terminals. Readings should match those shown in the following chart. If not, replace coil.

Terminals	Resistance Ω
1 to 2	1365 \pm 60
1 to 3	560 \pm 25
4 to 5	1325 \pm 55

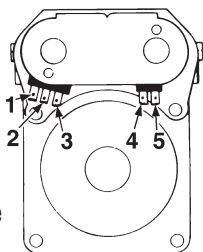

IMPORTANT:

Be sure all harness wires are looped back through the strain relief after checking or replacing coils.

TEST #5 Moisture Sensor

NOTE: This test is started with the dryer completely assembled.

This test is performed when an automatic cycle stops too soon, or runs much longer than expected.

NOTE: Dryer will shut down automatically after 2½ hours.

The following items are part of this system:

Harness/connection
Metal sensor strips
Machine control electronics. See ESD information, page 1.

1. Activate the Diagnostic Test Mode and advance past saved fault codes. See procedure on page 1.
 2. Open the dryer door. The dryer will beep and an alphanumeric number will be displayed.
 3. Locate the two metal sensor strips on the face of the lint screen housing. Using a wet cloth or one finger, jointly touch both strips.
 - If a beep tone is heard and an alphanumeric number is displayed on the console, the sensor passes the test. Go to step 9.
 - If a beep tone is not heard, or a continuous beep tone is heard before touching both moisture strips, continue with step 4.
- NOTE:** Overdrying may be caused by a short circuit in the sensor system.
4. Access the moisture sensor wires by removing the toe panel. See Removing the Toe Panel, page 9. Disconnect the sensor wires from the harness. See figure 12.

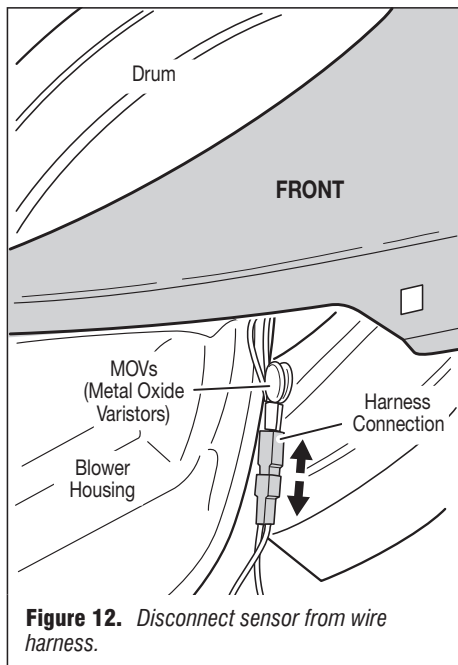
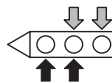
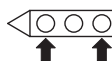

Figure 12. Disconnect sensor from wire harness.

5. Access the machine control electronics. See Accessing & Removing the Electronic Assemblies, page 9. Remove connector P13 from the circuit board. Check the main harness connections between the sensor harness and machine control for a short or open circuit.
 - Replace the main harness if necessary.
 - If harness is OK, continue with step 6.
6. Access the moisture sensor by removing the toe panel. See Removing the Toe Panel, page 9. Disconnect the sensor from the wire harness. See figure 12.
7. Measure the resistance across the outermost contacts of the cable that includes the two red MOVs.
 - If a small resistance is measured, check for debris across moisture strips inside the drum; clean if debris is present. If debris is not present, replace sensor harness.
 - If a small resistance is not measured, continue with step 8.
8. Measure the resistance across each of the outermost contacts and the center terminal (ground connection).
 - If a resistance less than infinity is measured, replace the sensor harness.
9. If moisture sensor diagnostic test passes, check the thermistor: Perform TEST #4a, page 7.
 - If the problem persists after replacing the moisture sensor and thermistor, replace the machine control electronics.



TEST #5a Adjusting Customer-Focused Drying Modes

NOTE: If the customer is complaining about the clothes being damp and the moisture sensor passes TEST #5, step 3, the total dry time can be lengthened by changing from a “CF1” (standard auto cycle) to a “CF2” (15% more drying time) or “CF3” (30% more drying time) auto cycle.

1. In Standby mode (dryer plugged in but not powered up), press and hold the Dryness Level button for 5 seconds. The dryer will beep and the current drying mode will be seen on the display. The factory default value is “CF1”.
2. To select a different drying mode, press the Dryness Level button again. The dryer display will flash and show CF2, CF3, or CF1.
3. With the display flashing the selected auto cycle mode, press the Start button to save the drying mode and exit diagnostics (the Start button in this mode does not start a drying cycle). The result will be stored in EEPROM of the control board, and will be retained after a power loss.
4. Press the Pause/Cancel button at any time to cancel changes and exit from this mode.

TEST #6 Buttons and Indicators

This test is performed when any of the following situations occurs during the Console Buttons and Indicators Diagnostic Test, page 1:

- ✓ None of the indicators light up
- ✓ No beep sound is heard
- ✓ Some buttons do not light indicators

None of the indicators light up:

1. See Diagnostic Guide/Before Servicing... on page 1.
2. Perform TEST #1, page 4, to verify supply connections.
3. Perform steps in Accessing & Removing the Electronic Assemblies, page 9, and visually check that the P5 connector is inserted all the way into the machine control electronics.
4. Visually check that the console electronics and housing assembly is properly inserted into the front console.
5. If both visual checks pass, replace the console electronics and housing assembly.
6. Plug in dryer or reconnect power.
7. Perform steps under DIAGNOSTIC: Console Buttons and Indicators, page 1, to verify repair.
8. If indicators still do not light, the machine control electronics has failed:
 - Unplug dryer or disconnect power.
 - Replace the machine control electronics.
 - Plug in dryer or reconnect power.
 - Perform steps under DIAGNOSTIC: Console Buttons and Indicators, page 1, to verify repair.

No beep sound is heard:

1. Perform steps in Accessing & Removing the Electronic Assemblies, at right, and visually check that the P5 connector is inserted all the way into the machine control electronics.
 - If visual check passes, replace the console electronics and housing assembly.
2. Plug in dryer or reconnect power.
3. Perform steps under DIAGNOSTIC: Console Buttons and Indicators, page 1, to verify repair.
4. If replacing the console electronics and housing assembly failed:
 - Unplug dryer or disconnect power.
 - Replace the machine control electronics.
 - Plug in dryer or reconnect power.
 - Perform steps under DIAGNOSTIC: Console Buttons and Indicators, page 1, to verify repair.

Some buttons do not light indicators:

1. Perform steps in Accessing & Removing the Electronic Assemblies, at right, and visually check that the console electronics and housing assembly is properly inserted into the front console.
 - If visual check passes, replace the console electronics and housing assembly.
2. Plug in dryer or reconnect power.
3. Perform steps under DIAGNOSTIC: Console Buttons and Indicators, page 1, to verify repair.

TEST #7 Door Switch

Refer to page 1 and perform steps under Activating the Diagnostic Test Mode. Then, on the same page, perform steps under DIAGNOSTIC: Door Switch. Functionality is verified with a beep each time the door is closed and opened, and an alphanumeric number appears in the display.

If any of the preceding conditions are not met:

1. Unplug dryer or disconnect power.
2. Check that the wires between the door switch and machine control electronics are connected. See figure 13 for switch location, and see Accessing & Removing the Electronic Assemblies, at right.

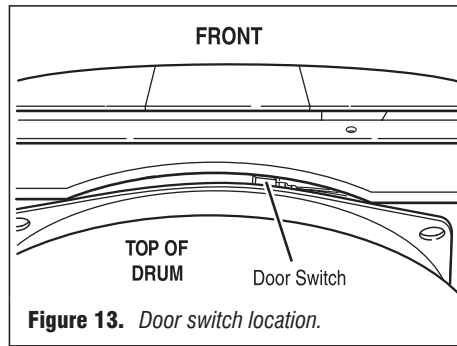

Figure 13. Door switch location.

- If the connections are OK, replace the wire and door switch assembly and retest.
- If wire and door switch assembly have been replaced and dryer still does not start, replace the machine control electronics.

REMOVING THE TOE PANEL

1. Unplug dryer or disconnect power.
2. Remove two screws below the toe panel.
3. Slide the toe panel down, then pull it out from the bottom. See figure 14.

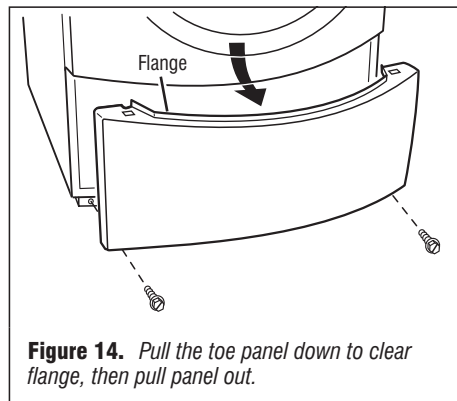

Figure 14. Pull the toe panel down to clear flange, then pull panel out.

ACCESSING & REMOVING THE ELECTRONIC ASSEMBLIES

There are two electronic assemblies: the Machine Control Electronics, and the Console Electronics and Housing. See figure 15.

1. Unplug dryer or disconnect power.
2. Remove the two rear screws from the top panel, and slide the top panel to the rear to remove.

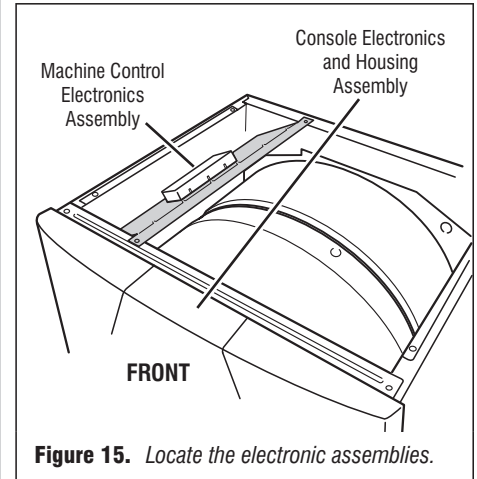

Figure 15. Locate the electronic assemblies.

Machine Control Electronics

1. Perform preceding steps 1 and 2, then remove the two screws that hold the machine control electronics bracket in place. See figure 16.
2. Slide the bracket over the top of the drum to access the machine control electronics connectors and mounting screw. See figure 16.

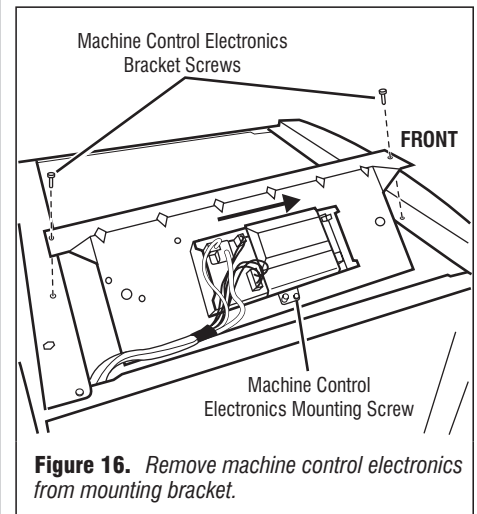

Figure 16. Remove machine control electronics from mounting bracket.

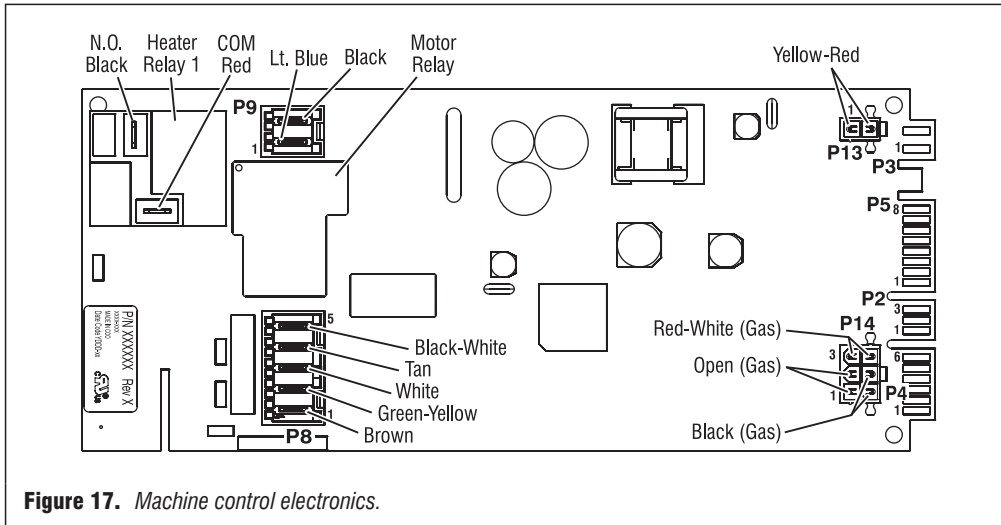

Figure 17. Machine control electronics.

3. Remove all the wire connections to the machine control electronics. See figure 17.
4. Remove the screw holding the machine control electronics assembly to the mounting bracket. See figure 16.
5. There are two plastic legs on the front of the machine control electronics that slide under the mounting bracket.
 - ✓ There is one plastic leg on the rear of the machine control electronics that slides under the mounting bracket.
 - ✓ There is a locking tab on the bottom of the machine control electronics that snaps into the mounting bracket.

Press the locking tab on the bottom of the machine control electronics and slide the assembly to the front, then lift.

Console Electronics and Housing Assembly

The console panel must be removed to access the console electronics and housing assembly.

1. Perform steps 1 and 2 under Accessing & Removing the Electronic Assemblies, page 9, and disconnect the P2 and P5 harnesses from the machine control.
2. Remove the screw that fastens the assembly to the machine control mounting bracket (figure 16, page 9), and the two screws that fasten the console assembly to the dryer (figure 18).

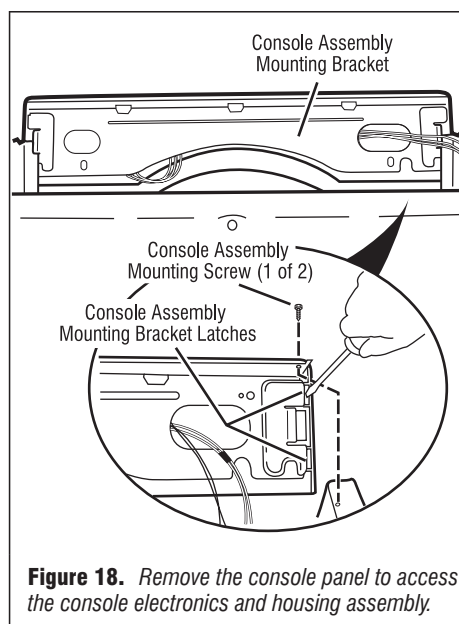

Figure 18. Remove the console panel to access the console electronics and housing assembly.

3. Gently remove the decorative trim that surrounds the door and upper console by unsnapping it from the dryer. See figure 19.

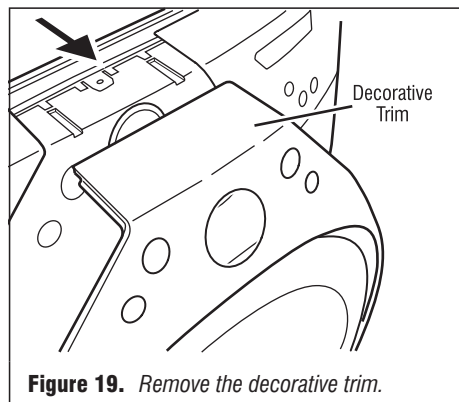

Figure 19. Remove the decorative trim.

4. Slide the console up and off of the dryer. See figure 18.

5. The console mounting bracket is fastened to the console front panel with two latches at both sides of the console assembly. Unlatch the bracket gently with a screwdriver while pulling the mounting bracket assembly out. See figure 18.
6. The console electronics is split into two assemblies connected by two cables. Each assembly is fastened to the decorative piece by four plastic latches. To remove these assemblies, gently compress the plastic latches while pulling up on the assembly. For the cycle selector assembly, the cycle selector knob must first be removed by firmly pulling on it or gently prying it straight upward. See figure 20.

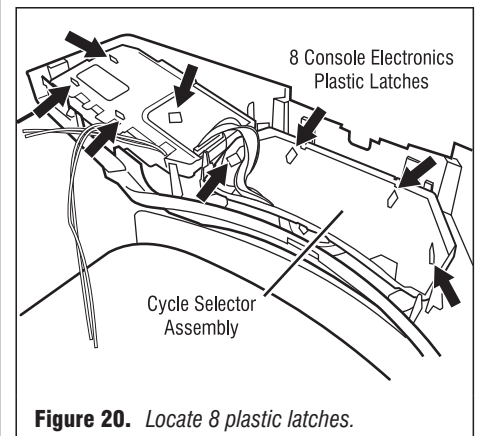

Figure 20. Locate 8 plastic latches.

REMOVING THE BACK PANEL

1. Unplug dryer or disconnect power.
2. Remove the two rear screws from the top panel, and slide the top panel to the rear to remove.
3. Remove the cover plate, disconnect the power cord, and remove ground screw.
4. Remove the metal spring clip between the back panel and the exhaust outlet. See figure 21.

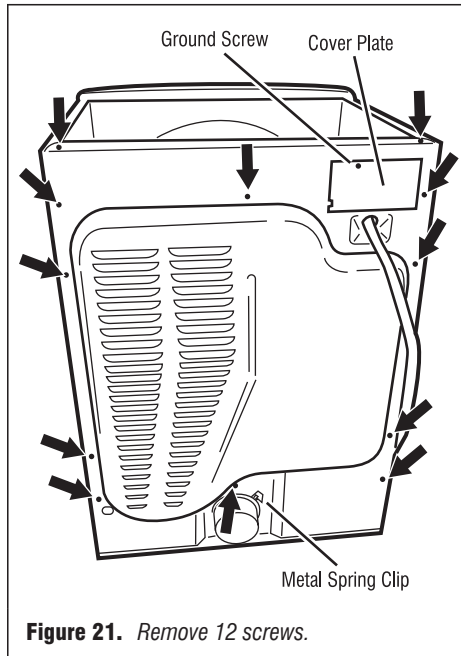

Figure 21. Remove 12 screws.

5. Remove the ten screws on the rear, and two screws on the top of the back panel. Pull the back panel off the dryer. See figure 21.

ELECTRIC DRYER: In addition to the above, remove the terminal block from the back panel.

Function	Contacts				
	1M	2M	3M	5M	6M
Start			●—●		
Run	●—●			●—●	

● = Contacts closed

Centrifugal Switch (Motor)

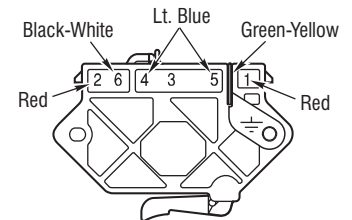

Pluggable Drive Motor Switch

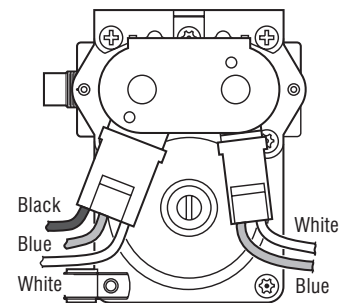

Gas Valve, Gas Dryer

SOFTWARE COPYRIGHTED.
 MANUFACTURED UNDER ONE OR MORE
 OF THE FOLLOWING U.S. PATENTS:

4669200	4989347	6446357	D314261
4700495	5066050	6597144	D314262
4754556	5560120	6604298	D457991
4840285	5809828	6685241	D457992
4865366	6020698	6732447	D495453
4899464	6047486	6784673	
4908959	6199300	6819255	

ELECTRIC DRYER WIRING DIAGRAM

IMPORTANT: Electrostatic (static electricity) discharge may cause damage to machine control electronics. See page 1 for details.

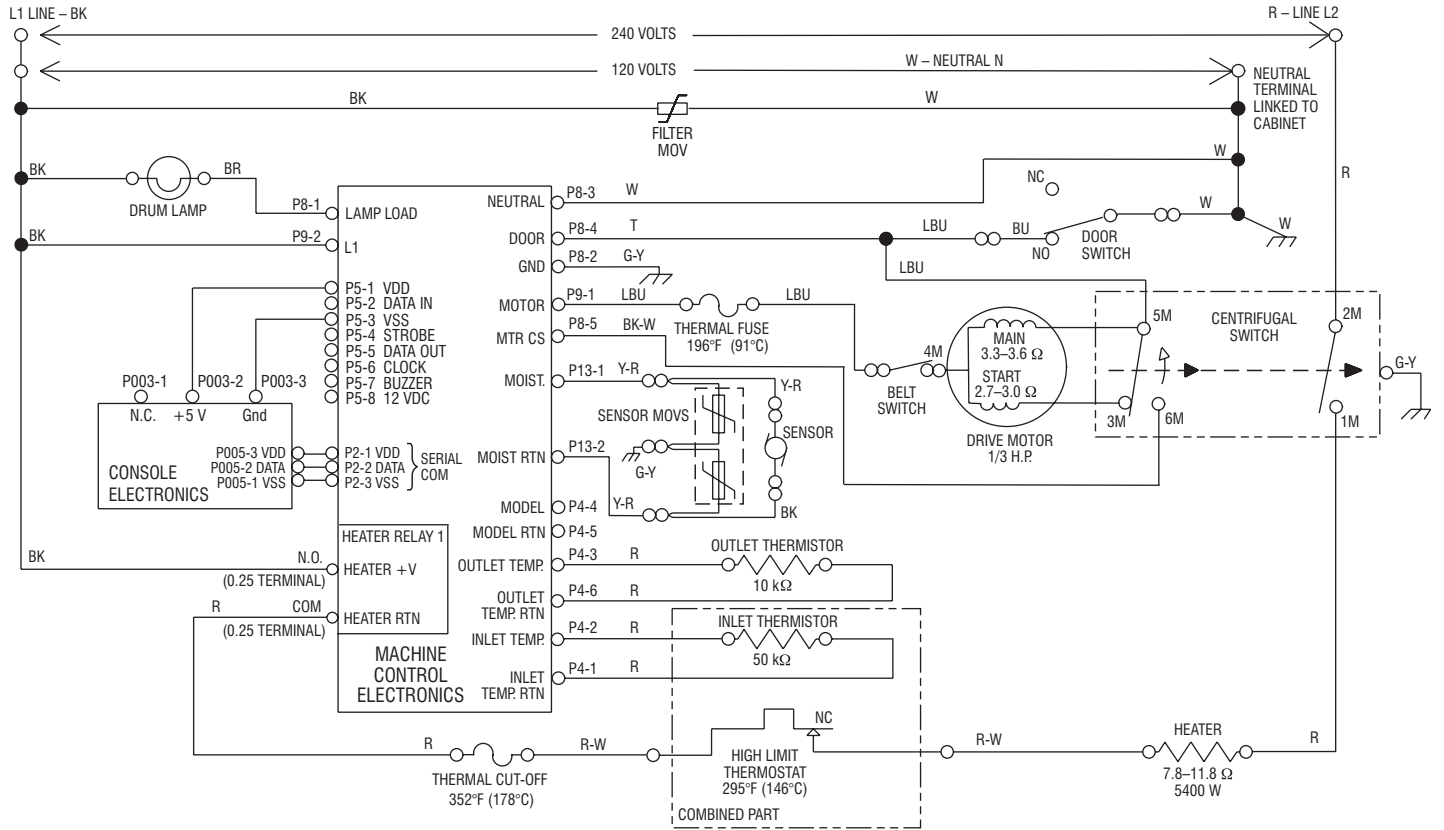

GAS DRYER WIRING DIAGRAM

