

# ADS-464

## Installation/Operator's Manual

**WARNING:** For your safety the information in this manual must be followed to minimize the risk of fire or explosion or to prevent property damage, personal injury or death.

- Do not store or use gasoline or other flammable vapor and liquids in the vicinity of this or any other appliance.

**AVERTISSEMENT:** Assurez-vous de bien suivre les instructions données dans cette notice pour réduire au minimum le risque d'incendie ou d'explosion ou pour éviter tout dommage matériel, toute blessure ou la mort.

- Ne pas entreposer ni utiliser d'essence ni d'autres vapeurs ou liquides inflammables dans le voisinage de cet appareil ou de tout autre appareil.

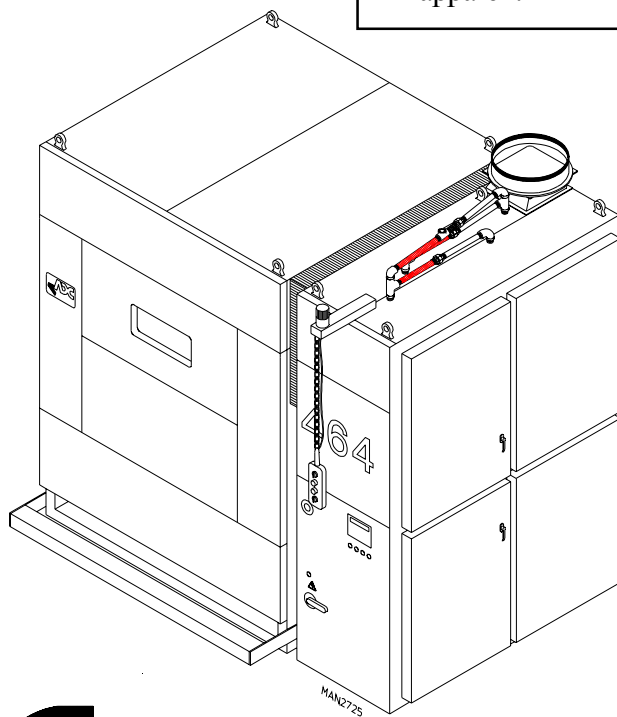

For replacement parts, contact the distributor from which the dryer was purchased or

**American Dryer Corporation**

88 Currant Road

Fall River MA 02720-4781

Telephone: (508) 678-9000 / Fax: (508) 678-9447

e-mail: [techsupport@amdry.com](mailto:techsupport@amdry.com)

010496

011899DX/mt

ADC Part No. 112103

# Retain This Manual In A Safe Place For Future Reference

American Dryer Corporation products embody advanced concepts in engineering, design, and safety. If this product is properly maintained, it will provide many years of safe, efficient, and trouble-free operation.

*ONLY qualified technicians should service this equipment.*

**OBSERVE ALL SAFETY PRECAUTIONS** displayed on the equipment or specified in the installation/operator's manual included with the dryer.

The following "FOR YOUR SAFETY" caution **must be** posted near the dryer in a prominent location.

**FOR YOUR SAFETY**

Do not store or use gasoline or other flammable vapors or liquids in the vicinity of this or any other appliance.

**POUR VOTRE SÉCURITÉ**

Ne pas entreposer ni utiliser d'essence ni d'autres vapeurs ou liquides inflammables dans le voisinage de cet appareil ou de tout autre appareil.

We have tried to make this manual as complete as possible and hope you will find it useful. **ADC** reserves the right to make changes from time to time, without notice or obligation, in prices, specifications, colors, and material, and to change or discontinue models.

## Important

For your convenience, log the following information:

DATE OF PURCHASE \_\_\_\_\_ MODEL NO. **ADS-464** \_\_\_\_\_

DISTRIBUTORS NAME \_\_\_\_\_

Serial Number(s) \_\_\_\_\_

\_\_\_\_\_

\_\_\_\_\_

Replacement parts can be obtained from your distributor or the **ADC** factory. When ordering replacement parts from the factory, you can FAX your order to **ADC** at (508) 678-9447 or telephone your orders directly to the **ADC** Parts Department at (508) 678-9000. Please specify the dryer **model number** and **serial number** in addition to the **description** and **part number**, so that your order is processed accurately and promptly.

## **IMPORTANT**

**YOU MUST DISCONNECT and LOCKOUT THE ELECTRIC SUPPLY and THE STEAM SUPPLY BEFORE ANY COVERS or GUARDS ARE REMOVED FROM THE MACHINE TO ALLOW ACCESS FOR CLEANING, ADJUSTING, INSTALLATION, or TESTING OF ANY EQUIPMENT per OSHA (Occupational Safety and Health Administration) STANDARDS.**

“Caution: Label all wires prior to disconnection when servicing controls. Wiring errors can cause improper operation.”

«Attention: Lor des opérations d’entretien des commandes étiqueter tous fils avant de les déconnecter. Toute erreur de câblage peut être une source de danger et de panne.»

## **CAUTION**

**DRYERS SHOULD NEVER BE LEFT UNATTENDED WHILE IN OPERATION.**

## **WARNING**

**CHILDREN SHOULD NOT BE ALLOWED TO PLAY ON OR NEAR THE DRYERS.**  
**CHILDREN SHOULD BE SUPERVISED IF NEAR DRYERS IN OPERATION.**

## **FOR YOUR SAFETY**

**DO NOT DRY MOP HEADS IN THE DRYER.**

**DO NOT USE DRYER IN THE PRESENCE OF DRY CLEANING FUMES.**

## **WARNING**

**UNDER NO CIRCUMSTANCES should the door switch or the heat circuit devices ever be disabled.**

**WARNING**

The dryer must never be operated with any of the back guards, outer tops, or service panels removed. **PERSONAL INJURY or FIRE COULD RESULT.**

**WARNING**

**DRYER MUST NEVER BE OPERATED WITHOUT THE LINT FILTER (SCREEN) IN PLACE, EVEN IF AN EXTERNAL LINT COLLECTION SYSTEM IS USED.**

**IMPORTANT**

**PLEASE OBSERVE ALL SAFETY PRECAUTIONS displayed on the equipment or specified in the installation/operator's manual included with the dryer.**

Dryers **must not** be installed or stored in an area where it will be exposed to water or weather.

The wiring diagram for the dryer is located in the front electrical control box area.

# *Table of Contents*

## **SECTION I**

<b>IMPORTANT INFORMATION .....</b>	<b>3</b>
A. Receiving and Handling .....	3
B. Safety Precaution .....	4

## **SECTION II**

<b>SPECIFICATIONS/DIMENSIONS.....</b>	<b>6</b>
A. Specification .....	6
B. Dimensions .....	7

## **SECTION III**

<b>INSTALLATION PROCEDURES .....</b>	<b>8</b>
A. Reassembly of Dryer .....	8
B. Location Requirements .....	11
C. Internal Air, Electrical, and Water Connections .....	12
D. External Supply Connections .....	18
E. Electrical Requirements .....	22
F. Fresh Air Supply Requirements .....	25
G. Steam Information .....	26
H. Shut Down Instructions .....	27

## **SECTION IV**

<b>PRE START-UP .....</b>	<b>28</b>
A. Preparation for Operation .....	28

## **SECTION V**

<b>ROUTINE MAINTENANCE.....</b>	<b>29</b>
A. Cleaning .....	29

## **SECTION VI**

<b>COMPONENT SYSTEM DESCRIPTIONS.....</b>	<b>31</b>
A. Tumbler Support and Drive System .....	31
B. Main Air Blower and Heat Reclaimer System .....	34
C. Compressed Air System .....	36
D. Safety Devices .....	39

**SECTION VIII**

**SERVICE/PARTS INFORMATION ..... 41**  
A. Service ..... 41  
B. Parts ..... 41

**SECTION VIII**

**WARRANTY INFORMATION ..... 42**  
A. Returning Warranty Cards ..... 42  
B. Warranty ..... 42  
C. Returning Warranty Parts ..... 42

**SECTION IX**

**TROUBLESHOOTING ..... 44**  
Troubleshooting TOC ..... 44  
A. Power Malfunctions ..... 45  
B. Tumbler (Basket) Electrical Malfunctions ..... 56  
C. Base Section Electrical Malfunctions ..... 64  
D. Pendant Control Malfunctions ..... 68  
E. Temperature Sensing ..... 71  
F. Motors ..... 74  
G. PLC (Programmable Logic Controller) Messages ..... 76

# SECTION I

## IMPORTANT INFORMATION

### A. RECEIVING and HANDLING

The dryer is shipped in a protective stretch wrap cover with protective cardboard corners and top cover (or optional box) as a means of preventing damage in transit. Upon delivery, the dryer and packaging, and wooden skid should be visually inspected for shipping damage. If any damage whatsoever is noticed, inspect further before delivering carrier leaves.

Dryers damaged in shipment.

1. **ALL** dryers **should be** inspected upon receipt and before they are signed for.
2. If there is suspected damage or actual damage, the trucker's receipt **should be** so noted.
3. If the dryer is damaged beyond repair, it **should be** refused. Those dryers which were not damaged in a damaged shipment **should be** accepted, but the number received and the number refused **must be** noted on the receipt.
4. If you determine that the dryer was damaged after the trucker has left your location, you should call the delivering carrier's freight terminal immediately and file a claim. The freight company considers this concealed damage. This type of freight claim is very difficult to get paid and becomes extremely difficult when more than a day or two passes after the freight was delivered. It is your responsibility to file freight claims. Dryer or parts damaged in transit **cannot** be claimed under warranty.
5. Freight claims are the responsibility of the consignee, and **ALL** claims **must be** filed at the receiving end. **ADC** assumes no responsibility for freight claims or damages.
6. If you need assistance in handling the situation, please contact the **ADC** Traffic Manager at (508) 678-9000.

<p><b>IMPORTANT:</b> The tumbler section of the dryer <b>must be</b> transported and handled in an upright position at all times.</p>
---

## B. SAFETY PRECAUTIONS

**WARNING:** For your safety, the information in this manual *must be* followed to minimize the risk of fire or explosion or to prevent property damage, personal injury, or loss of life.

**WARNING:** The dryer must never be operated with any of the back guards, outer tops, or service panels removed. **PERSONAL INJURY or FIRE COULD RESULT.**

1. **DO NOT** store or use gasoline or other flammable vapors and liquids in the vicinity of this or any other appliance.
2. Dryers **must be** exhausted to the outdoors.
3. Although ADC produces a very versatile machine, there are some articles that, due to fabric composition or cleaning method, **should not** be dried in it.

**WARNING:** Dry only water-washed fabrics. **DO NOT** dry articles spotted or washed in dry cleaning solvents, a combustible detergent or “all purpose” cleaner.  
**EXPLOSION COULD RESULT.**

**WARNING:** **DO NOT** dry rags or articles coated or contaminated with gasoline, kerosene, oil, paint or wax.  
**EXPLOSION COULD RESULT.**

**WARNING:** **DO NOT** dry mop heads. Contamination by wax or flammable solvents will create a fire hazard.

**WARNING:** **DO NOT** use heat for drying articles that contain plastic, foam, sponge rubber or similarly textured rubber materials. Drying in a heated basket (tumbler) may damage plastics or rubber and also may be a fire hazard.

4. A program **should be** established for the inspection and cleaning of lint in the burner area, exhaust duct work, and inside the dryer. The frequency if inspection and cleaning can best be determined from experience at each location.

**WARNING:** The collection of lint in the burner area and exhaust duct work can create a potential fire hazard.

5. For personal safety, the dryer **must be** electrically grounded in accordance with local codes and/or the NATIONAL ELECTRIC CODE ANSI/NFPA NO. 70-LATEST EDITION, or in Canada, the CANADIAN ELECTRICAL CODES PARTS 1 & 2 CSA C22.1-1990 or LATEST EDITION.

**NOTE:** Failure to do so will VOID THE WARRANTY.

6. **UNDER NO CIRCUMSTANCES** should the dryer door switches, lint drawer switches, heat safety circuit, or tilt switches ever be disable.

**WARNING: PERSONAL INJURY or FIRE COULD RESULT.**



7. This dryer is not to be used in the presence of dry cleaning solvents or fumes.
8. Remove articles from the dryer as soon as the dryer cycle has been completed.

**WARNING:** Articles left in the dryer after the drying and cooling cycles have been completed can create a fire hazard.

9. **READ and FOLLOW ALL CAUTION and DIRECTION LABELS ATTACHED TO THE DRYER.**

**WARNING: YOU MUST DISCONNECT and LOCKOUT THE ELECTRICAL SUPPLY and THE STEAM SUPPLY BEFORE ANY COVERS or GUARDS ARE REMOVED FROM THE MACHINE TO ALLOW ACCESS FOR CLEANING, ADJUSTING, INSTALLATION OR TESTING OF ANY EQUIPMENT per OSHA (Occupational Safety and Health Administration) STANDARDS.**

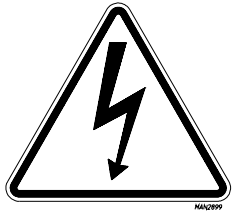

The lightning flash with an arrow head within an equilateral triangle, is intended to alert the user to the presence of non-insulated “dangerous voltage” within the products enclosure that may be sufficient in magnitude to constitute a risk of electrical shock to any person.



The Exclamation point “!” within an equilateral triangle is intended to alert the user to the presence of important operating and maintenance (servicing) instructions in the literature accompanying the appliance.

# SECTION II

## SPECIFICATIONS/DIMENSIONS

### A. SPECIFICATIONS

MAXIMUM CAPACITY (DRY WEIGHT)	460 lbs.	<b>208.66 kg</b>
Total Weight	10,500 lbs.	<b>4,762.7 kg</b>
Total Shipping Weight	10,800 lbs.	<b>4,898.8 kg</b>
Tilt Height	137-1/4"	<b>348.6 cm</b>
Operating Height	114-1/2"	<b>290.83 cm</b>
Full Tilt Depth	117-1/2"	<b>298.45 cm</b>
Operating Depth	95"	<b>241.3 cm</b>
Width	122"	<b>309.88 cm</b>
Tilt Load (REAR TILT)		15°
Tilt Unload (FRONT TILT)		15°
Loading Height from Floor	65-5/8"	<b>166.69 cm</b>
Tumbler (BASKET) Diameter	69-1/8"	<b>175.58 cm</b>
Tumbler (BASKET) Depth	80-5/16"	<b>203.99 cm</b>
Tumbler (BASKET) Volume	175 cu. ft.	<b>4.96 cu. m</b>
Minimum Load Size	250 lbs.	<b>113.4 kg</b>
Maximum Load Size	460 lbs.	<b>208.66 kg</b>
Blower Motor	25 HP	<b>18.64 kw</b>
Tumbler (BASKET) Motors (2 MOTORS)	(2) 5 HP	<b>(2) 3.73 kw</b>
Boiler Horsepower		60 Bhp
Steam Inlet Size Connection	2-1/2" N.P.T.	---
Burner Blower Motor	1-1/2 HP	<b>1.12 kw</b>
Blower Maximum Airflow	13,000 cfm	<b>368 cmm</b>
Maximum Duct Back Pressure	1.25" W.C.	<b>3.1 mbar</b>
Minimum Duct Diamemter	24"	<b>60.96 cm</b>
Compressed Air Pressure Required	80 psi (±10 psi)	<b>551.6 kpa (±68.95 kpa)</b>
Compressed Air Volume Required	20 cf/hr	<b>.57 cm/hr</b>
Compressed Connection	3/8" N.P.T.	---

*Shaded areas are stated in metric equivalents*

**NOTE:** ADC reserves the right to make changes in specifications at any time, without notice or obligation.

# B. DIMENSIONS

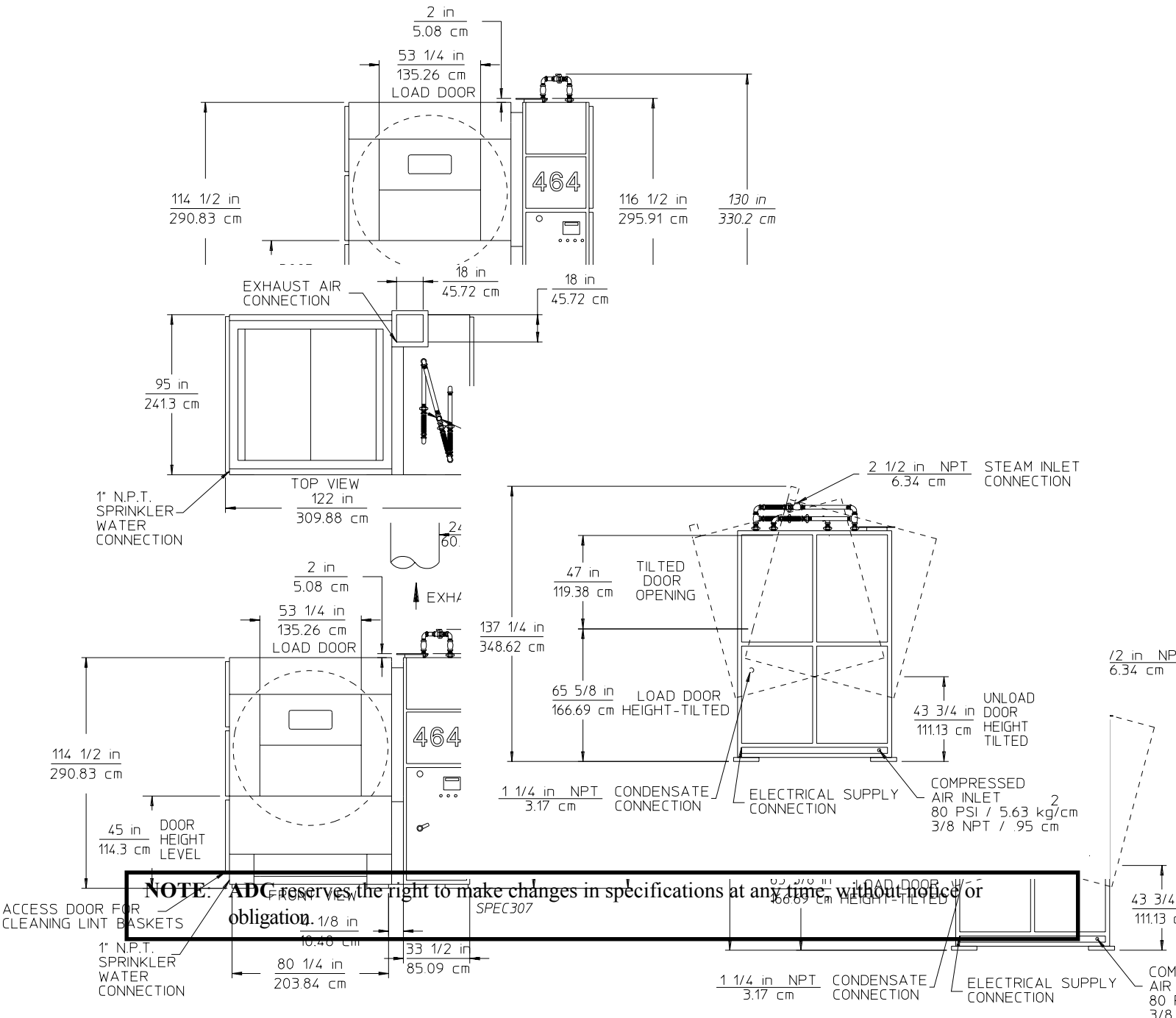

# SECTION III

## INSTALLATION PROCEDURES

Installation should be performed by competent technicians in accordance with local and state codes. In the absence of these codes, the installation **must conform** to applicable NATIONAL ELECTRIC CODE ANSI/NFPA NO. 70-LATEST EDITION, or in Canada, the CANADIAN ELECTRICAL CODES PARTS 1 & 2 CSA C22.1-1990 or LATEST EDITION.

### A. REASSEMBLY OF DRYER

**IMPORTANT:** Always keep the tumbler (basket) section of the dryer in an upright position when moving it.

#### 1. Reassembly Instructions for Dryer Shipped in Two (2) Pieces

In this method of shipment, the tumbler section and the tumbler base section are shipped as one unit and the heat console section is the second.

##### a. Reassemble Tumbler (Basket) and Tumbler (Basket) Base Section To The Heat Console Section

Move both pieces into position by lifting them with cables through the eyebolts located at the top of each of the two sections. These pieces may also be moved into place with a fork (lift) truck by lifting the pieces from underneath. The tumbler and tumbler base section weighs about 6,400 pounds (2,903 kg) and the heat console section weighs about 4,100 pounds (1,860 kg). Once the sections are in position, the seven (7) clearance holes on the tumbler (basket) base section (four [4] in the front and three [3] in the rear) **must be** aligned with the seven (7) #3/8-16 tapped holes in the heat console section. Use the three (3) #8-16 x 2" long bolts along with the tapered shims supplied to bolt the two sections together.

##### b. Reattach The Control Pendant Arm

Position the control pendant arm to the top front of the heat console section by aligning the clearance holes in the arm with the 1/4-20 tapped holes on the top of the heat console section. Use the 1/4-20 x 3" long bolts supplied with the machine to attach the arm to the console.

##### c. Reconnect The Internal Air, Electric Connections, and Water Connections (refer to **page 12** through **page 18**).

## 2. Reassembly Instructions For Dryers Shipped In Three (3) Pieces

When the dryer is shipped in three (3) pieces, the tumbler and the tumbler base sections are shipped as two (2) separate pieces. The heat console section is shipped as the third piece.

### a. Reassemble The Tumbler (Basket) Base Section To The Heat Console Section

Move the heat console section into position by using cables through the eye bolts located at the top of the section or by using a fork truck and lifting the section from underneath. The tumbler (basket) base section is now moved into position with a fork (lift) truck. The seven (7) clearance holes located on the right side of the tumbler (basket) base section (four [4] holes in front and three [3] at the back of the section) **must be** aligned with the seven (7) 3/8-16 tapped holes on the left side of the heat console section. Use the 3/8-16 x 3" long bolts and the tapered shims supplied with the unit to bolt the section together.

### b. Reassemble The Tumbler (Basket) Section Over The Tumbler (Basket) Base

Slowly lower the tumbler (basket) section over the tumbler base. The four (4) large slots located on the bottom of the tumbler (basket) section (one slot at each corner of the tumbler [basket] section) **must be** aligned with the top of the pistons in the tumbler base section. Use the four (4) 1-1/4-12 x 3-1/2" long bolts supplied with the unit to secure the tumbler (basket) section to the tumbler (basket) base section.

### c. Reattach The Control Pendant Arm

Position the control pendant arm to the top front of the heat console section by aligning the clearance holes in the arm with the 1/4-20 tapped holes on the top of the heat console section. Use the 1/4-20 x 3" long bolts supplied with the machine to attach the arm to the console.

### d. Reconnect The Internal Air, Electric Connections, and Water Connections (refer to **page 12 through page 18**).

## 3. Reassembly Instructions for Dryer Shipped in Four Pieces

In this method of shipment the tumbler section, tumbler (basket) base, lower heat console, and upper heat console are **ALL** shipped as separate sections.

### a. Reassemble The Heat Console Section

Apply silicone (provided with unit) to the flanges of the lower heat console section. Lift the upper heat console section by use of cables through the eyebolts located on the top of the upper console section. Position the upper heat console over the lower heat console section. Use the 5/16-18 hardware provided with the machine to secure the sections together.

### b. Reassemble The Tumbler (basket) Base Section To The Heat Console Section

Move the heat console section into position by using cables through the eyebolts located at the top of the section or by using a fork (lift) truck and lifting the section from underneath. The tumbler (basket) base section is now moved into position with a fork (lift) truck. The seven (7) clearance holes located on the right side of the tumbler (basket) base section (four [4] holes in the front and the three [3] at the back of the section) **must be** aligned with the seven 3/8-16 tapped holes on the left side of the heat console section. Use the 3/8-16 x 2" long bolts and the tapered shims supplied with the unit to bolt the sections together.

c. Reassemble The Tumbler (Basket) Section To The Tumbler (Basket) Base

Lift the tumbler (basket) section with a cable through the eye bolts on top of the section. Slowly lower the tumbler (basket) section over the tumbler base. The four (4) large slots located on the bottom of the tumbler (basket) section (one slot at each corner of the tumbler section) **must be** aligned with the tapped holes in the cylinder cleaves located at the top of the tumbler (basket) section. Use the four (4) 1-1/4-12 x 3-1/2" long bolts supplied with the unit to secure the tumbler (basket) section to the tumbler (basket) base section.

d. Reattach The Control Pendant Arm

Position the control pendant arm on the top front of the heat console section by aligning the clearance holes in the arm over the 1/4-20 tapped holes in the top of the heat console section. Use the 1/4-20 x 3" long bolts supplied with the unit to attach the arm to the console.

e. Reconnect The Internal Air, Electric Connections, and Water Connections (refer to **page 12 through page 19**).

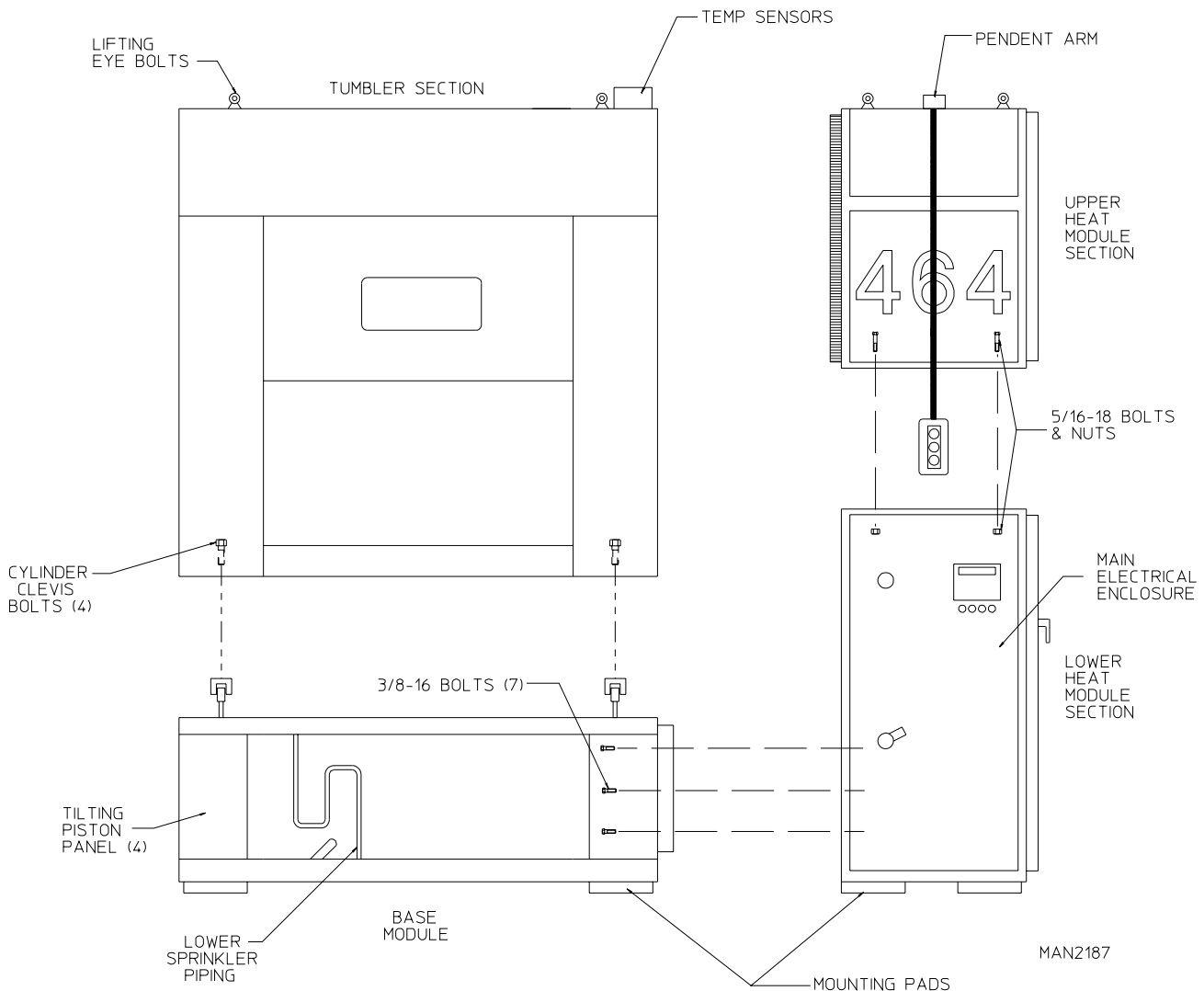

## B. LOCATION REQUIREMENTS

The model ADS-464 dryer requires 36-inches of space on each side of the dryer and 36-inches of space behind the unit for ease of maintenance and tilting. The dryer **must be** leveled for proper operation. If shimming is required, put 9-1/2" x 9-1/2" metal shims under the base feet. The dryer **must be** lagged to the floor.

**IMPORTANT:** Dryer *should be* located where a minimum amount of exhaust duct will be necessary.

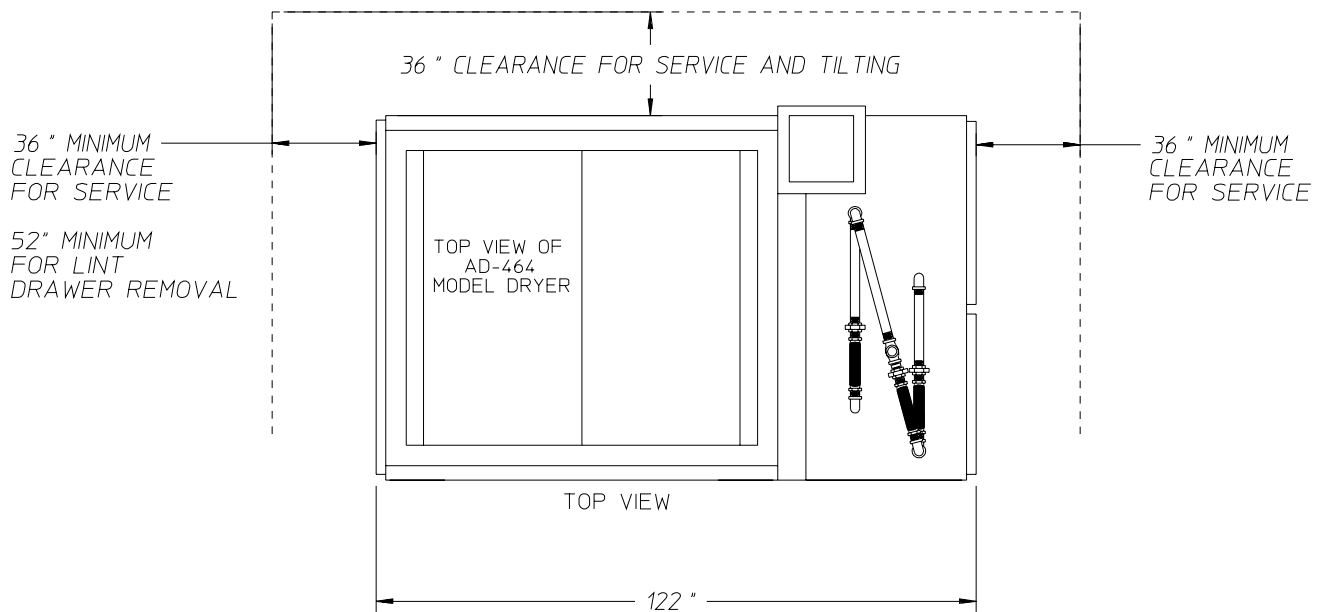

CLEARANCE ALLOWANCE

MAN4609

## C. INTERNAL AIR, ELECTRICAL and WATER CONNECTIONS

### 1. Air

#### a. Front Tilt Piston and Sprinkler lines

This connection is made at the front of the dryer in the area between the lower heat console section and the tumbler (basket) base section. To connect the sprinkler air line insert the 1/4" aluminum tubing into the 1/4" brass compression fitting and tighten the fitting nut. To connect the 3/8" poly-flo tubing to the corresponding brass fittings, match the marked number on the tube with the number on the brass fitting. After inserting the corresponding tubes into the brass fittings. Tighten the brass fitting nuts.

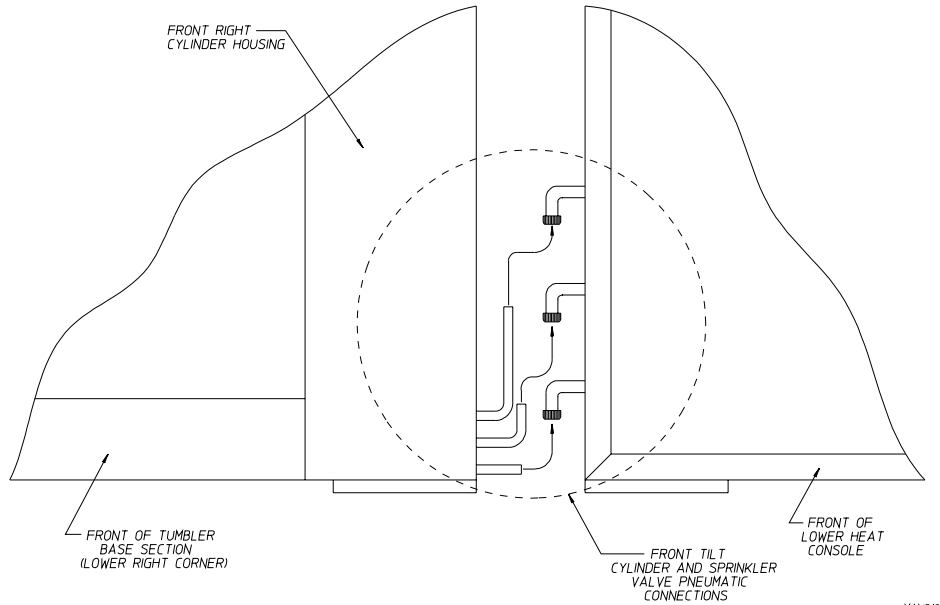

#### b. Rear Tilt Piston Lines

This connection is made at the rear of the dryer in the space between the lower heat console section and the tumbler (basket) base section. Insert the 3/8" poly-flo tube coming from the tumbler (basket) base section to the 3/8" brass fitting marked with the corresponding number. Do the same to the second tube and brass fitting. Tighten the brass fitting nuts.

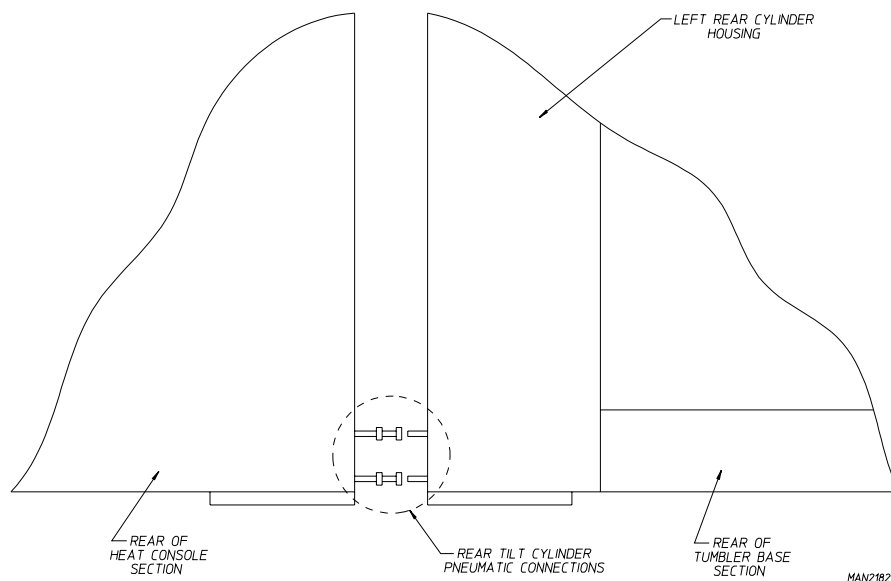



c. Load Door Piston Air Lines and Cool Down Damper Piston Air Lines

The load door cylinder pneumatic connections are made in the lower heat console section, in the area behind the pneumatic panel. To connect the 1/4" poly-flo lines into the corresponding needle valves, match the number on the line with the number on the needle valve. Insert **ALL** of the air lines to make sure that the connections are complete. Repeat this process for the two (2) cool down piston air lines.

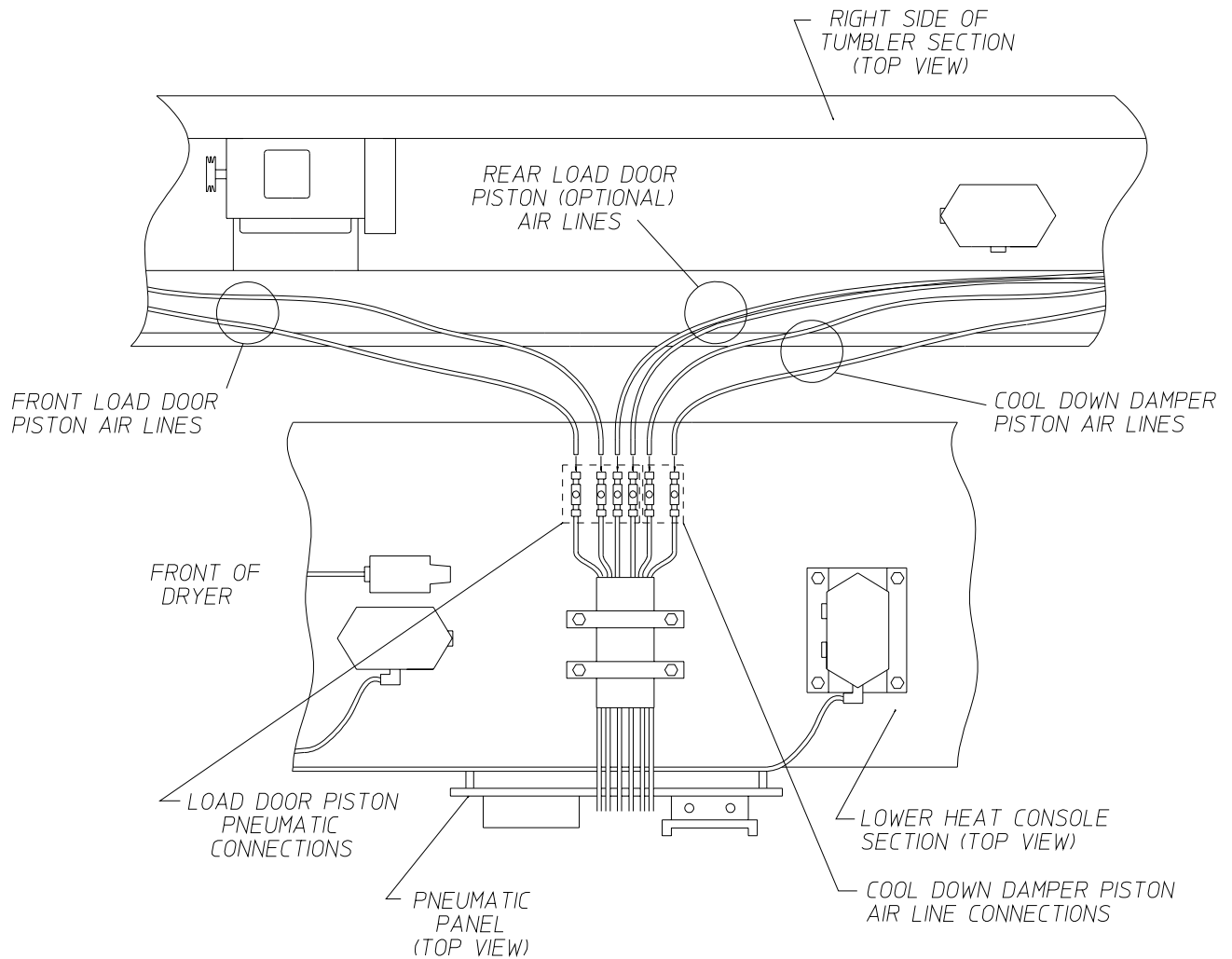

MAN2797

## 2. Electric

### a. Tumbler (Basket) Motors

The disconnects for the two (2) tumbler (basket) motors are located in the lower heat console. The right drum (tumbler/basket) motor disconnect is located in the lower heat console on the upper shelf towards the left. The left drum (tumbler/basket) motor disconnect is located in the base of the lower heat console to the right. On both cables the mechanical connections **should be** made to the respective junction box. Remove the two (2) screws that hold down the cover of each junction box. Insert cable end in the junction box and fasten with lock nut. Then begin to connect the four (4) wires with the same color tape identifiers together with the four (4) wires already in the junction box. Make these connections with wire nuts and PVC electrical tape. Replace the cover and the cover (2) screws that hold down the cover to the junction box.

### b. Temperature Probe, Base, and Tumbler (Basket) Disconnects

The disconnects are located in the lower heat console. The temperature probe disconnect is located on the upper shelf towards the left. The base disconnect and the tumbler (basket) disconnect are located on the base towards the right. Check identifying tapes to ensure proper assignments of connectors to the proper base. Check for proper keying and connect disconnect to the proper base. Engage hold downs on base and verify that the clamps are properly locked.

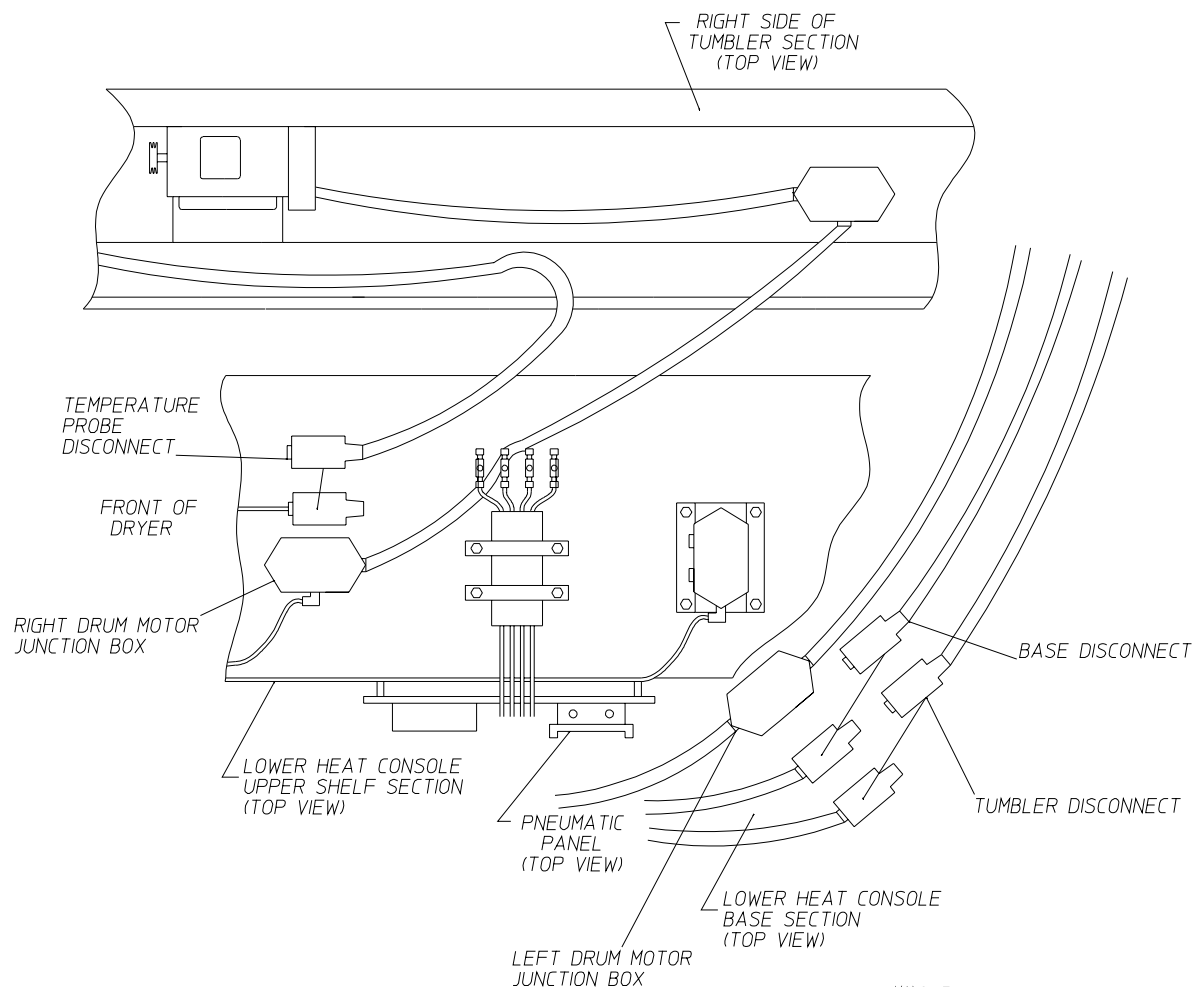

MAN2467

c. Annunciator, Pendant, Over-Burner, and RTD (Resistive Temperature Device) Cable

Remove the four (4) bolts that hold on the character (464) panel. Open the door to the main electrical enclosure, the female end of the RTD (Resistance Temperature Device) cable will be found there. Loosen the 1-inch lock nut and remove the modified hole seal. Put the female end of the RTD cable through the hole in the top of the electrical enclosure. Connect the male end and the female end of the RTD cable together, pull the cable up until the threads of the reducing bushing can be seen through the hole into where the character (464) panel was. Next, get the 1-inch lock nut on by a few threads, slip the modified hole seal under the lock nut holding the 45° cord grip connector, then tighten the 1-inch lock nut. Replace the character (464) panel and tighten the four (4) bolts.

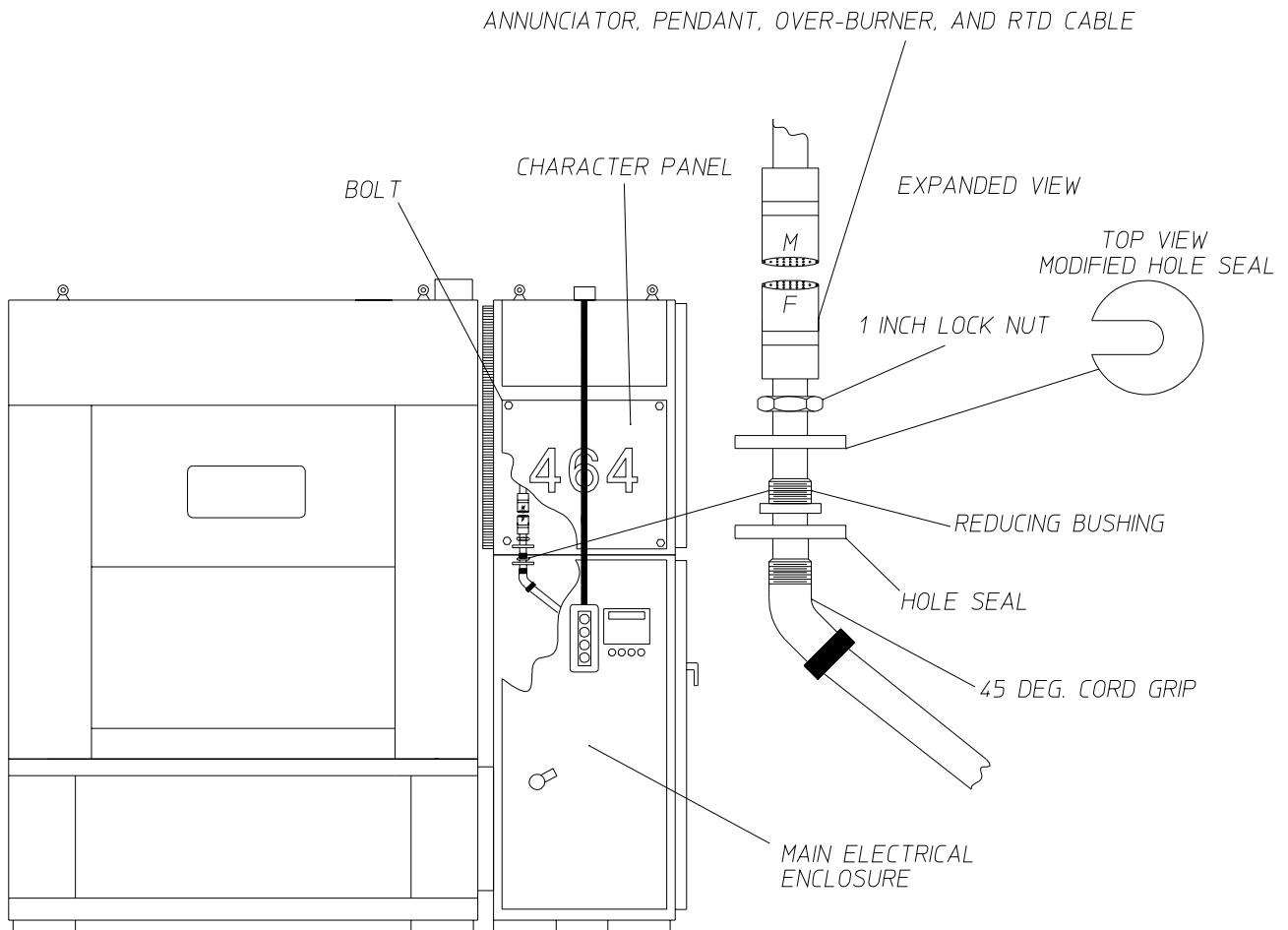

MAN2468

d. Pendant

On the top of the heat console section of the dryer near the pendant, there is a junction box with four (4) cables coming out of it. Two (2) of the cables from the junction box have connectors on the end, a 5-pin connector and an 11-pin connector. Coming out of the pendant **should be** two (2) cables, one with a 5-pin connector and the other with an 11-pin connector. Match up the four (4) cables into assigned pairs, check keying and connect the male and female connection together.

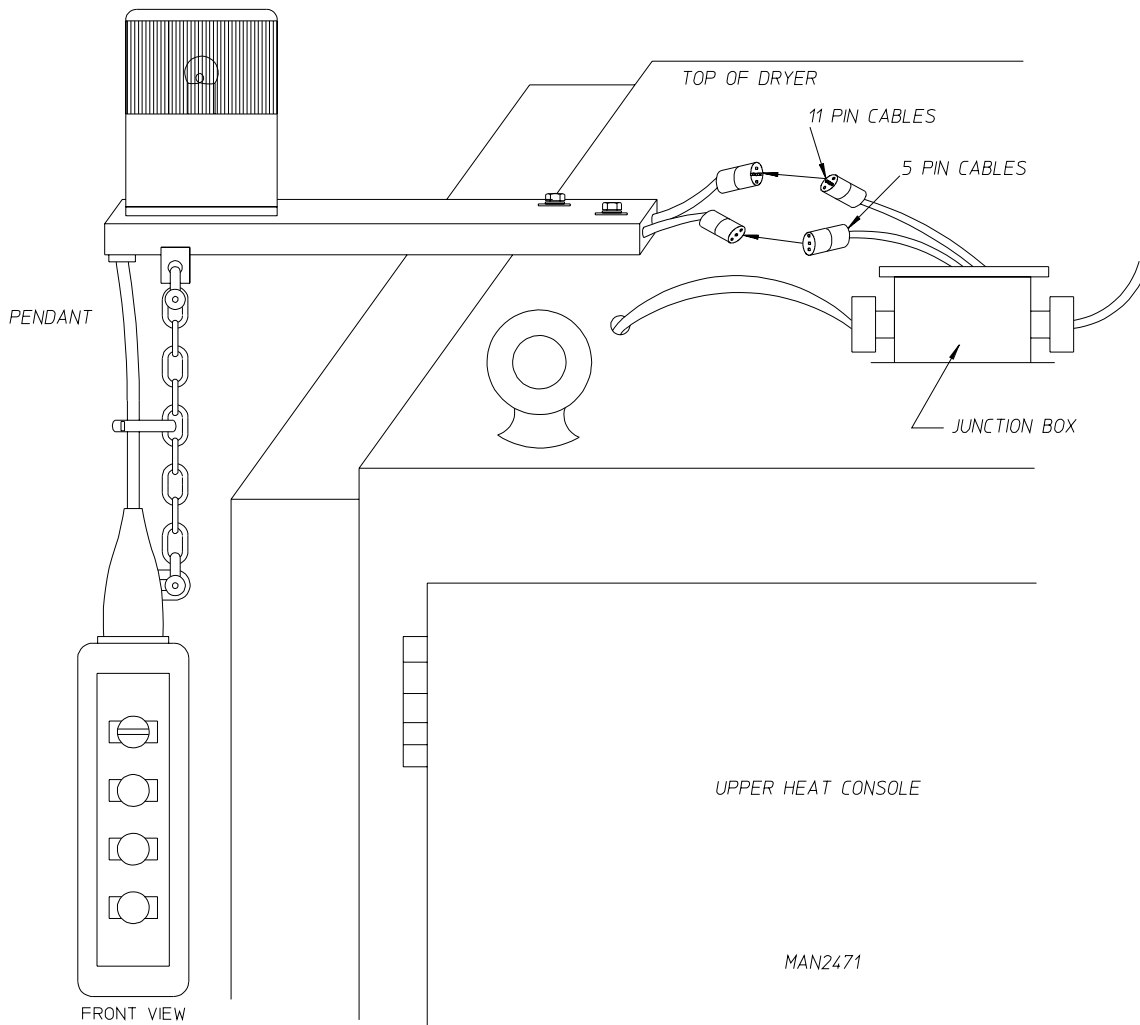

e. Tumbler Junction Box Disconnect

Remove the four (4) bolts that hold on the lower left side panel, then remove the panel. The safety panel is next to be removed. This is done by removing the six (6) bolts on the bottom of the safety panel where the tumbler section and the base meet. Reach into the feed through hole in the base of the tumbler section, there will be two (2) cables there. Pull both cables through the hole into the tumbler section. The cable Leave that cable in the tumbler section (it will be covered in *Section f below* [Left Drum Motor]). Check keying between the plug and tumbler junction box. Insert plug into connector on the junction box and engage locking clasps. Leave the lower left side panel and the safety panel off the machine until left drum motor is reconnected (refer to *Section f below* [Left Drum Motor]).

f. Left Drum Motor

There are two (2) different ways that the left drum motor is connected with or without the motor disconnected junction box. The junction box is used when the connections to the left motor are made on the back side of the motor, nearest to the tumbler basket. When connecting the motor, bring the left drum motor cable (refer to *Section e above* [Tumbler Junction Box Disconnect]) and mechanically connect it to the junction box on the motor or the external junction box with the lock nut. There will be four (4) wires in the cable, match them with the PVC electrical tape. There **should be** one (1) green wire remaining, which is used for the ground connection. Replace the screws that go on the cover of the junction box. Bolt the safety panel back in place using the six (6) bolts removed in *Section e above* (Tumbler Junction Box Disconnect), then bolt the lower left side panel back in to place using the four (4) bolts also removed in *Section e above* (Tumbler Junction Box Disconnect).

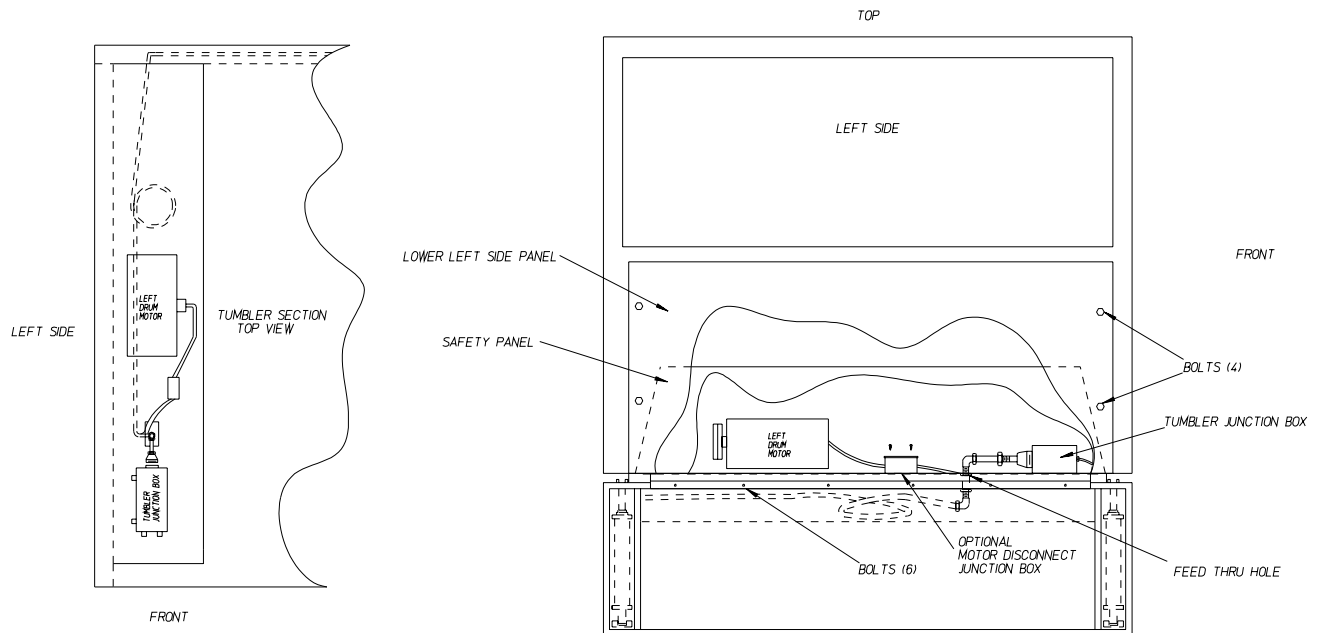

MAN2469

## D. EXTERNAL SUPPLY CONNECTIONS

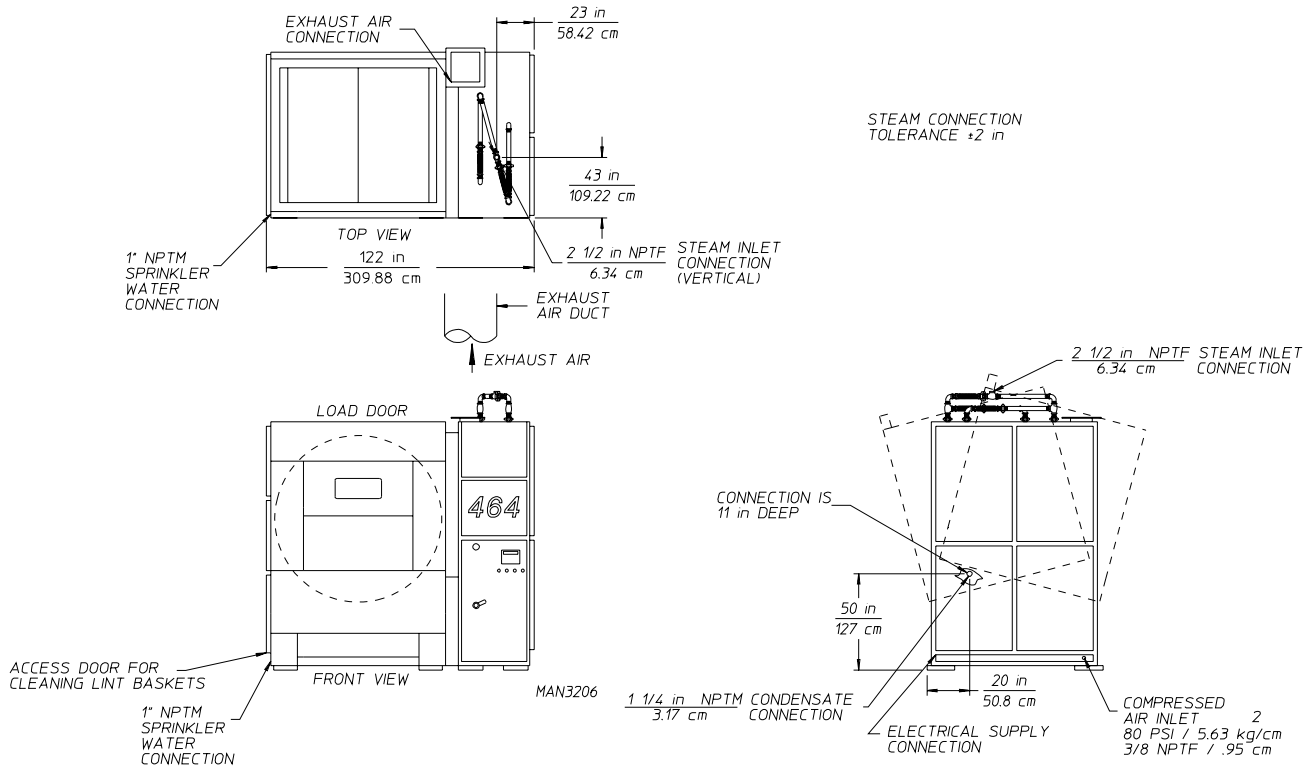

### 1. Sprinkler Water Supply

A 40 PSI supply of water **must be** connected into the 1" N.P.T. sprinkler connection located on the left side of the tumbler base.

### 2. Compressed Air Supply

A minimum of 20 cubic feet per hour (cfh) at 80 PSI of dry, clean, and regulated compressed air **must be** supplied to the dryer.

The compressed air supply **must be** connected into the 3/8" F.P.T. fitting which is located in the rear corner of the lower heat console section.

### 3. Steam Supply and Condensate Return Connections

The steam supply into the dryer is made into the 2-1/2" F.T.P. pipe fitting located on top of the heat module console.

The maximum operating steam supply pressure is 150 psig (10.34 bar).

The presence of condensate in the steam supply will cause water hammer and subsequent steam coil (battery) failure. The steam supply connection out of the main supply line must be made with a minimum 10-inch riser. This will reduce the amount of condensate in the steam supply.

Use flexible couplings at the supply and return connections. The dryer vibrates slightly when it runs and the piping connections may crack if they are hard piped to the dryer. Install shut-off valves in the supply and return lines.

An inverted bucket steam trap with an internal check valve is included with the dryer. The supply lines **should be** insulated. This will save energy and provide for the safety of the operator and maintenance personnel.

Water pockets in the supply line, caused by low points, will provide wet steam to the coil possibly causing steam coil damage. **ALL** horizontal runs of steam supply piping should be pitched 1/4-inch for the header. Install a bypass trap in any low point to eliminate wet steam.

The condensate return line **must be** 1-1/4" (3.18 cm) pipe.

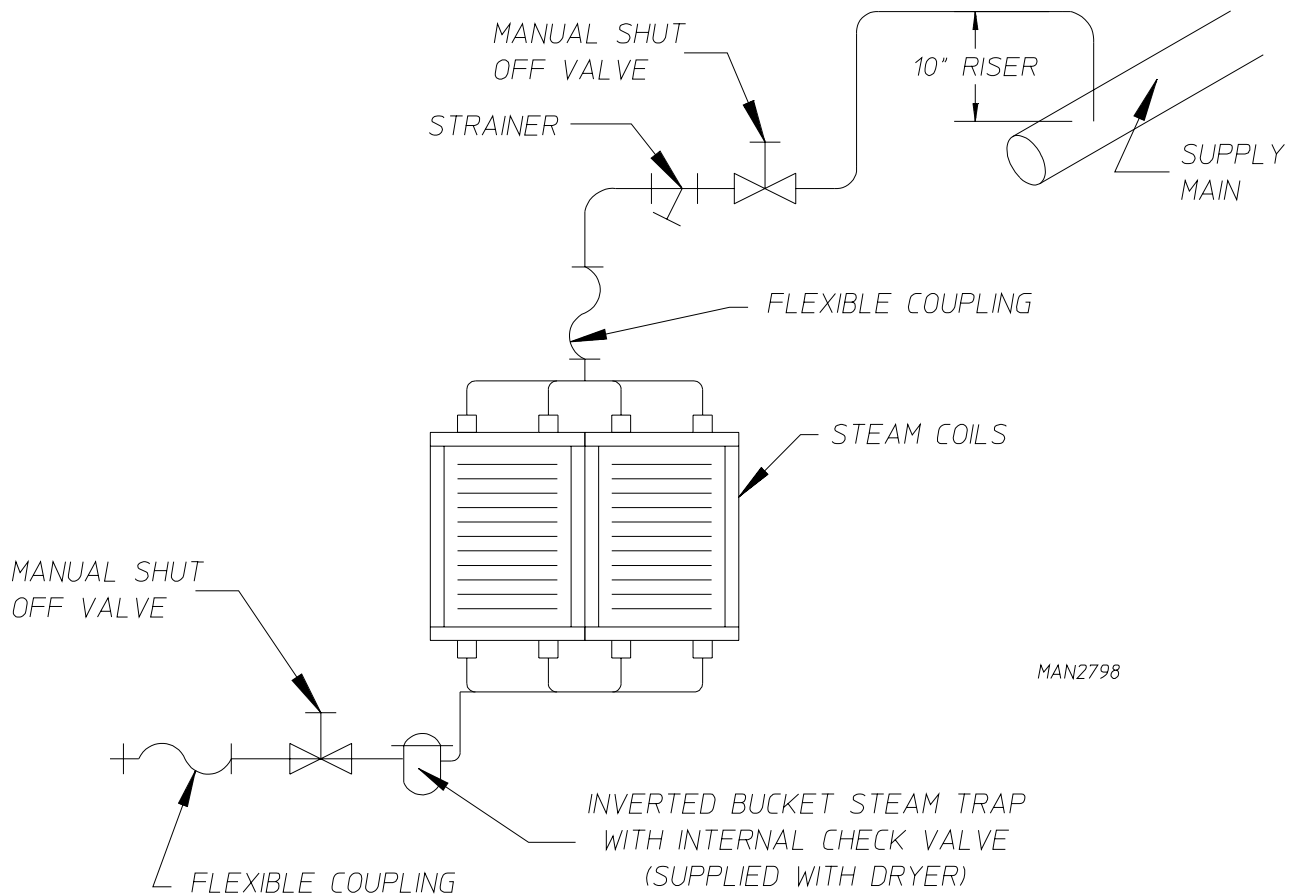

#### 4. Exhaust Ducting

The dryer's exhaust air **must be** vented to the outdoors by the shortest route possible with the number of elbows kept to a minimum. The duct **should be** designed and installed by qualified technicians.

Improperly designed duct work may reduce the airflow through the dryer, causing improper and unsafe drying conditions. The static pressure of the air in the duct work **must not** exceed 1.25 inches water column (3.10 millibar). The dryer exhausts 11,600 cfm (328.5 cmm) of air during the drying cycle, 13,000 cfm (368.2 cmm) during cool down. Ducting **must be** sized for the 13,000 cfm (368.2 cmm) of airflow.

The exhaust vent connection is located on top of the burner and heater section of the dryer. It has a rectangle cross section and is flanged.

A sheet metal transition piece is supplied to connect a 24-inch diameter exhaust duct to the dryer's exhaust vent connection. Care **must be** taken in locating this transition piece so that the tilting tumbler section does not hit the transition piece.

The duct work connecting the vent to the outdoors **must be** a minimum of 24-inches in diameter for a round duct or 625 square inches for a rectangular duct (a 22-inch square duct would be sufficient).

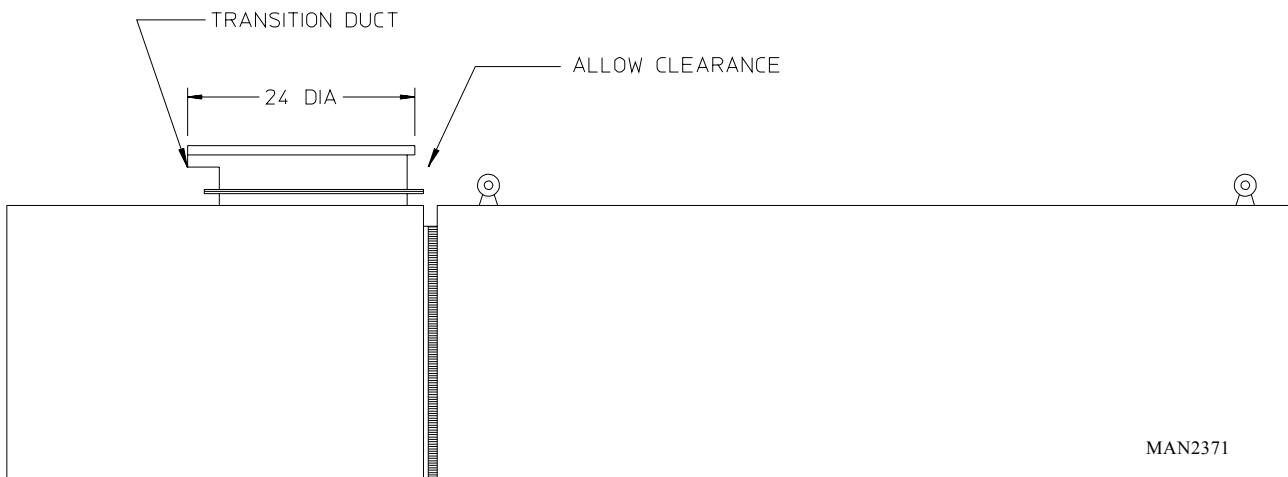



The duct work **must be** smooth on the inside with no projections from sheet metal screws or other obstructions which would collect lint. Inspection doors **must be** installed at strategic points in the duct work for periodic lint removal.

Use smooth sweeping elbows instead of sharp 90° elbows. The radius of an elbow **should be** at least 1-1/2 times the duct diameter.

When the exhaust duct goes through a combustible wall on a roof, leave a 2-inch clearance space between the exhaust ducting and the wall or roof.

When adding ducts, the duct that leaves the building **must be** protected from the weather. For horizontal ducting use a 90° turned downward. For vertical duct work use a 180° turned downward. In either case, allow at least twice the diameter of the duct between the duct opening and nearest obstruction. (If the duct is rectangular, leave twice the smallest face dimension.)

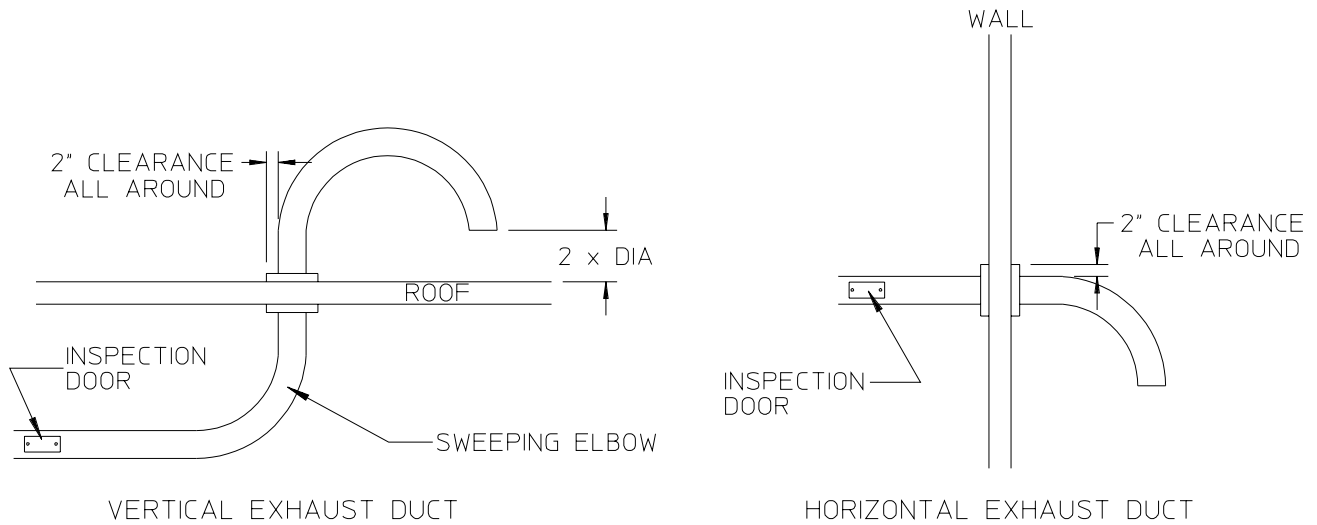

MAN0631

**IMPORTANT:** ***DO NOT*** use screen or caps on the outside opening of the exhaust duct work. Screens will clog with lint and caps will restrict the exhaust airflow.

## E. ELECTRICAL REQUIREMENTS

### 1. Electrical Requirements

It is your responsibility to have **ALL** electrical connections made by a properly licensed and competent electrician to assure that the electrical installation is adequate and conforms with local and state regulations or codes. In the absence of such codes, **ALL** electric connections, materials and workmanship **must confirm** to the applicable requirements of the National Electrical Code ANSI/NFPA NO. 70-LATEST EDITION or in Canada, the CANADIAN ELECTRICAL CODES PARTS 1 & 2 CSA C22.1-1990 or LATEST EDITION.

**IMPORTANT:** Failure to comply with these codes or ordinances or requirements stipulated in this manual can result in personal injury or component failure.

**NOTE:** Component failure due to improper installation will VOID THE WARRANTY.

Each dryer **should be** connected to an independently protected branch circuit. *The dryer **must be connected with copper wire ONLY. DO NOT use aluminum wire which could cause a fire hazard.*** The copper conductor wire or cable **must be** of proper ampacity and insulation in accordance with electric codes for making **ALL** service connects

**NOTE:** The use of aluminum wire will VOID THE WARRANTY.

2. Electrical Service Specifications

<b>ADS-464 (Steam)</b>							
ELECTRICAL SERVICE SPECIFICATIONS (PER DRYER)							
<b>IMPORTANT:</b> 208 VAC and 230/240 VAC <b>ARE NOT THE SAME</b> . When ordering, specify <i>exact voltage</i> .							
<b>NOTES:</b> A. Fuse ratings are dual-element, time-delay, current limiting, class RK1 or RK5 <b>ONLY</b> . B. Circuit breakers are thermal magnetic (industrial) type <b>ONLY</b> . For others, calculate/verify correct breaker size according to appliance amp draw rating and type of breaker used. C. Circuit breakers for 3Ø dryer <b>must be</b> 3-pole type.							
SERVICE VOLTAGE	PHASE	WIRE SERVICE	APPROX. AMP DRAW		MINIMUM WIRE SIZE	FUSING	CIRCUIT BREAKER
			60 Hz	50 Hz		Dual Element Time Delay	
208 @ 60 Hz	3Ø	3/4	99	99	1/0	150	150
240 @ 50/60 Hz	3Ø	3/4	93	93	1	125	125
380 @ 50 Hz	3Ø	3/4	---	57	4	90	90
416 @ 50 Hz	3Ø	3/4	---	55	4	80	90
460 @ 60 Hz	3Ø	3/4	51	---	4	60	90
DEDICATED SPRINKLER SERVICE							
Dryer Nameplate	1Ø	---	2		16	3.5	5

**IMPORTANT:** The dryer *must be* connected to the electric supply shown on the data label that is affixed to the right side of the main electrical enclosure. In the case of 208 VAC or 230/240 VAC, the supply voltage *must match* the electric service specifications of the data label *exactly*.

**WARNING:** **208 VAC and 230/240 VAC ARE NOT THE SAME**. Any damage done to the dryer components due to improper voltage will automatically **VOID THE WARRANTY**.

**IMPORTANT:** For proper sprinkler and dryer operation, sprinkler *must be* powered by a “separate or dedicated” single-phase (1Ø) multi-wire branch circuit at dryer’s nameplate voltage.

**NOTE:** For 4-wire service, cap the neutral.

**NOTE:** Contact the factory for electrical information not listed.

**NOTE:** ADC reserves the right to make changes in specifications at any time, without notice or obligation.

### 3. Electrical Service

The electrical power is connected the dryer at the high voltage section of the control cabinet. On the ADS-464 dryer, this section is located at the bottom left of the main electrical enclosure.

The ADS-464 dryer, with sprinkler option, **must be** supplied with two (2) independent input power lines. One is 3-phase (3 $\phi$ ) electric service that feeds the dryer itself, and the other is single-phase (1 $\phi$ ) electric service that feeds the safety sprinkler system. *Both input lines must be independent of each other and individually protected by their own individual fused disconnect.*

**IMPORTANT: THE ADS-464 WILL NOT OPERATE WITHOUT AN INDEPENDENT POWER SOURCE FED TO THE SAFETY SPRINKLER SYSTEM.**

Feed the electrical service cables to the dryer using the pre-punched knockouts at the bottom section of the electrical cabinet right wall.

Connect the ground wires directly to the ground lug located at the same approximate area.

Before turning power on to the dryer, measure the supply voltage to ensure that it matches the dryer's specified input voltage. This input voltage is marked on the aluminum data plate located on the inner right wall of the electrical cabinet.

**IMPORTANT:** For proper sprinkler and dryer operation, sprinkler **must be** powered by a "separate or dedicated" single-phase (1 $\phi$ ) multi-wire branch circuit at dryer's nameplate voltage.

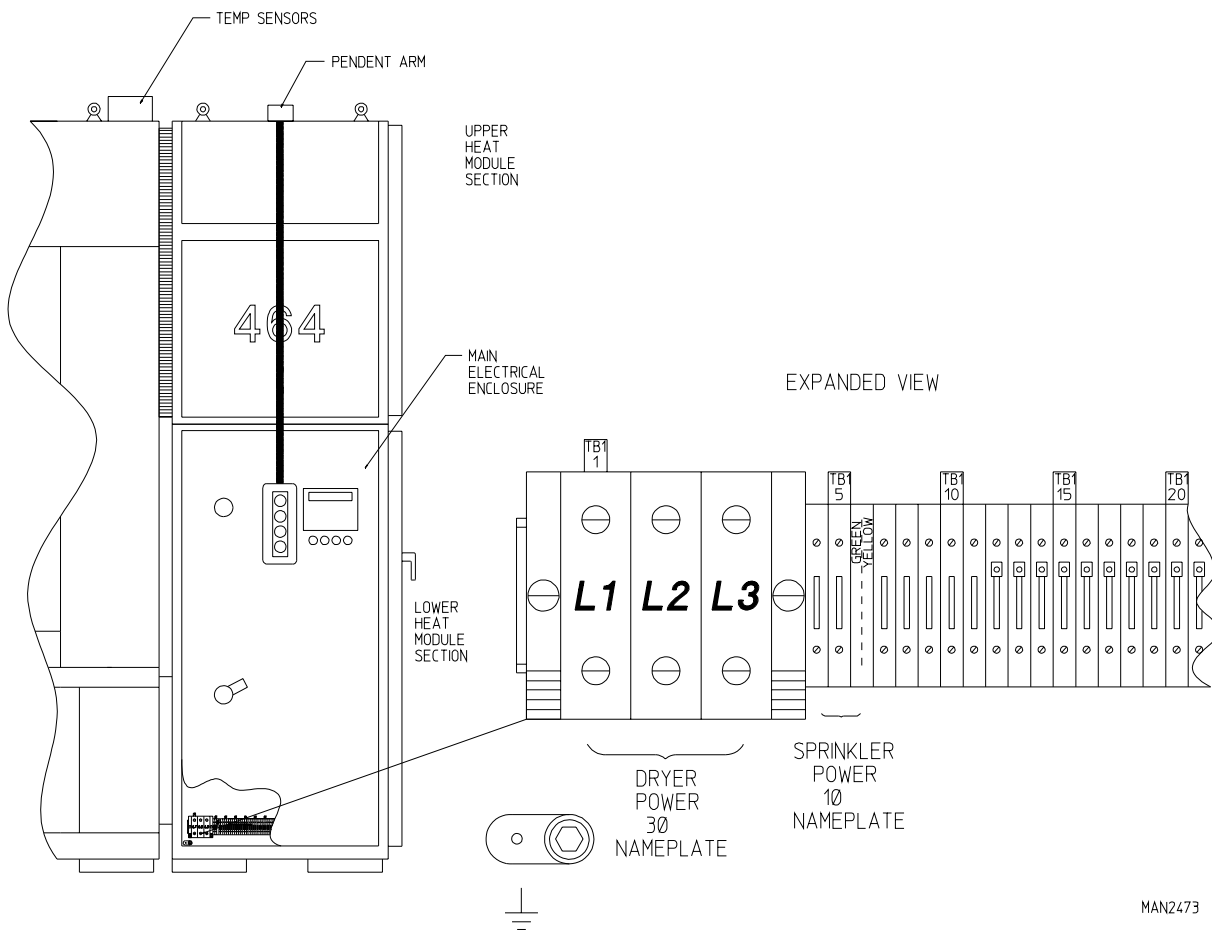

MAN2473

## F. FRESH AIR SUPPLY REQUIREMENTS

When the dryer is operating, it draws in room air, heats this air through the tumbler (basket), and exhausts it out of the building. Therefore, the room air **must be** continually replenished from the outdoors. If makeup air is inadequate, drying time and efficiency will be adversely affected, and safety will be compromised. Premature component failure may result.

Air supply (make-up air) **must be** given careful consideration to assure proper performance of each dryer. An unrestricted source of air is necessary for each dryer. An airflow of 13,000 cfm (cubic feet per minute) **must be** supplied to each dryer. As a general rule, an unrestricted air entrance from the outdoors (atmosphere) of a minimum twenty (20) square feet is required for each dryer.

To compensate for the use of registers or louvres used over the openings, the makeup air area **must be** increased by approximately thirty-three percent (33%). Makeup air openings **should not** be located in an area directly near where exhaust vents exit the building.

Allowances **must be** made for remote or constricting passageways or where dryers are located at excessive altitude or predominantly low pressure areas.

**IMPORTANT:** Make-up air **must be** provided from a source free of dry cleaning solvent fumes. Make-up air that is contaminated by dry cleaning solvent fumes will result in irreparable damage to the motors and other dryer components.

**NOTE:** Component failure due to dry cleaning solvent fumes will VOID THE WARRANTY.

## G. STEAM INFORMATION

It is your responsibility to have **ALL** plumbing connections made by a qualified professional to assure that the steam plumbing installation is adequate and conforms with local and state regulations or codes.

**IMPORTANT:** Failure to comply with the requirements stipulated in this manual can result in component failure which will VOID THE WARRANTY.

**NOTE:** The ADS-464 is manufactured with a pneumatic (piston) damper system which requires an external supply of air (80 psi  $\pm$  10 psi).

### 1. Steam Coil PH Level

The normal PH level for copper type steam coils must be maintained between a value of 8.5 to 9.5. For steel type steam coils the PH level must be maintained between a value of 9.5 to 10.5. These limits are set to limit the acid attack of the steam coils.

**IMPORTANT:** Coil failure due to improper PH level will VOID THE WARRANTY.

### 2. Steam Requirements

Inlet ----- 2" supply line connection

Return -- 1-1/4" return line connection

<b>OPERATING STEAM PRESSURE</b>		
MAXIMUM	150 psig	<b>10.5 kg/sq cm.</b>
MINIMUM	100 psig	<b>7.03 kg/sq cm.</b>
HEAT INPUT (NORMAL LOAD)	60 bph	
CONSUMPTION (APPROXIMATE)	1,980 lbs/hr	<b>900 kg/hr</b>

*Shaded areas are in metric equivalents*

### 3. Installation Instructions

To ensure an adequate supply of steam is provided, be sure that the steam lines and return lines are sized and laid out as stipulated in this manual. Inadequate steam lines and return lines or improper steam plumbing will result in poor performance and can cause component failure. Clean dry steam **must be** provided to the dryer.

**IMPORTANT:** Steam coil failure due to hammer by wet steam will VOID THE WARRANTY.

- a. The presence of the condensate in the steam supply will cause water hammer and subsequent heat exchanger (steam coil) failure. The steam supply connection into the main supply line **must be** made with a minimum 10-inch riser. This will prevent any condensate from draining toward the dryer.
- b. The steam supply piping to the dryer *must include* a 12-inch rise along with a drip trap and check valve. This will prevent and condensate from entering the steam coil.

- c. Flexible hoses or couplings **must be** used. The dryer vibrates slightly when it runs and this will cause the steam coil connections to crack if they are hard piped to the supply and return mains.
- e. A 3/4" vacuum breaker should be installed for each unit in the piping. This will prevent the condensing steam from causing a vacuum inside the coil and possibly damaging the coil.
- f. The supply line and return line should be insulated. This will save energy and provide for the safety of the operator and the maintenance personnel.
- g. Water pockets in the supply line, caused by low points, will provide wet steam to the coil possibly causing steam coil damage. **ALL** horizontal runs of steam supply piping should be pitched 1/4-inch for every one (1) foot back towards the steam supply header causing the condensate in the line to drain to the header. Install a bypass trap in any low point to eliminate wet steam.

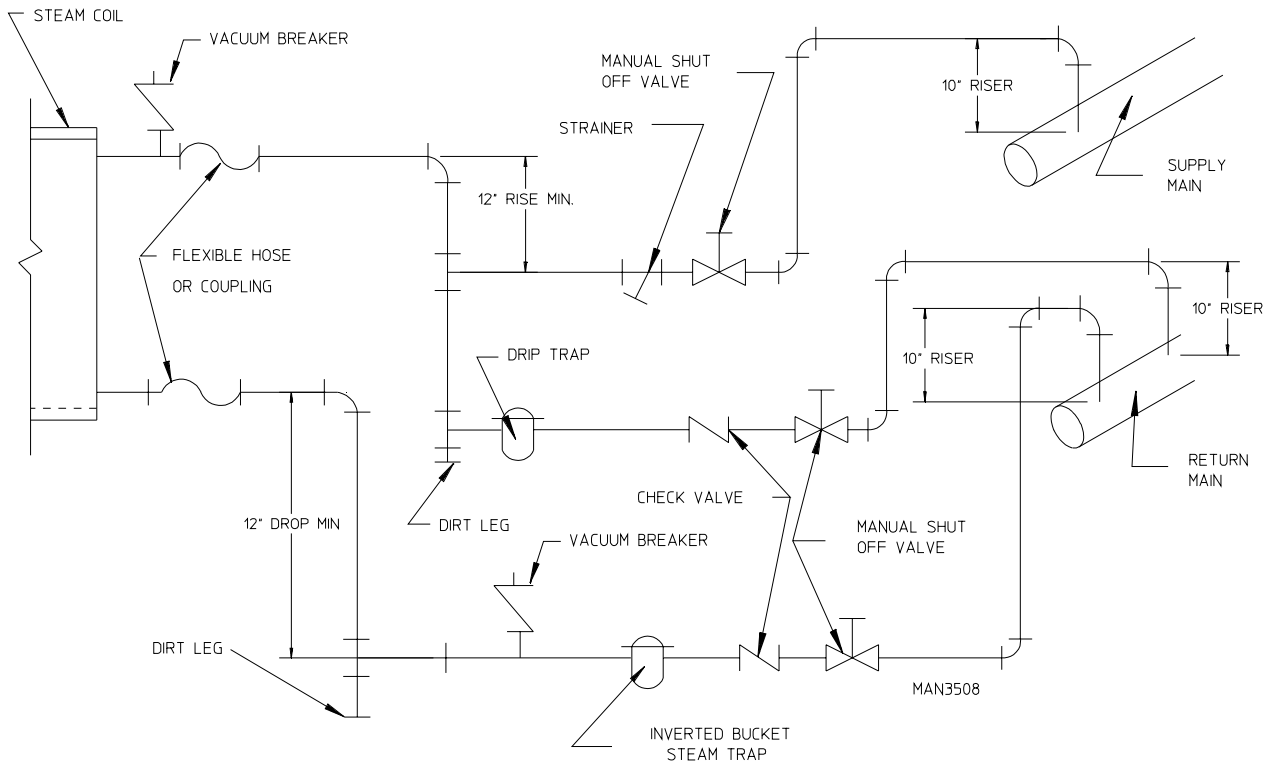

## H. SHUT DOWN INSTRUCTIONS

In the case where the dryer is to be shut down (taken out of service) for a period of time, the following **MUST BE** performed;

1. Discontinue power to the dryer either at the external disconnect switch or the circuit breaker.
2. Disconnect the heat supply:
  - a. **STEAM MODELS** ... discontinue steam supply.
    - 1) **SHUT OFF external (location furnished) shut-off valve.**
    - 2) **SHUT OFF internal steam valves in the supply lines and the return lines.**

# SECTION IV

## PRE START-UP

### A. PREPARATION FOR OPERATION

1. The supply voltage **must match** the dryer voltage as stated on the aluminum dryer data label which is located on the inner right wall of the electrical cabinet.
2. A separate fused power supply **must be** connected into safety sprinkler circuit power connection.
3. Open **ALL** steam supply lines and condensate return line shut-off valves.
4. A compressed air supply of 80 PSI **must be** connected into the dryer's fitting located at the rear corner of the lower heat console section.
5. The dryer exhaust duct **must be** vented to the outdoors.
6. A water supply of 40 PSI **must be** connected into the 1-inch sprinkler pipe connection.
7. The dryer **must be** lagged to the floor and leveled for proper operation.
8. A fresh air supply from the outdoors of 13,000 cfm (368 cmm) **must be** available to the dryer.
9. **ALL** service doors **must be** closed and all access panels and tilt guards **must be** installed on the dryer.



# SECTION V

## ROUTINE MAINTENANCE

### A. CLEANING

A program or schedule **should be** established for periodic inspection, cleaning, and removal of lint from various areas of the dryer, as well as throughout the duct work system. The frequency of this cleaning can best be determined from experience at each location. Maximum operating efficiency is dependent upon proper air circulation. The accumulation of lint can restrict this air flow. If the guidelines in this section are met, an ADC dryer will provide many years of efficient, trouble free and safe operation.

**WARNING: LINT FROM MOST FABRICS IS HIGHLY COMBUSTIBLE. THE ACCUMULATION OF LINT CAN CREATE A POTENTIAL FIRE HAZARD.**

**WARNING: KEEP DRYER AREA CLEAR AND FREE FROM COMBUSTIBLE MATERIALS, GASOLINE AND OTHER FLAMMABLE VAPORS AND LIQUIDS.**

**NOTE:** Suggested time intervals shown are for average usage which is considered six (6) to eight (8) operational (running) hours per day.

**NOTE:** Remove power from the machine before performing any maintenance in the machine (cleaning the lint drawers and both steam coil lint screens are the only exceptions).

### SUGGESTED CLEANING SCHEDULE

#### ***EVERY THIRD OR FOURTH LOAD***

Clean lint accumulation for lint drawers

Clean lint accumulation from the burner lint screens

**NOTE:** The frequency of cleaning the lint screens can best be determined from experience at each location.

#### ***WEEKLY***

Clean any lint accumulation from inside the heat console

**WARNING: TO AVOID THE HAZARD OF ELECTRICAL SHOCK, DISCONTINUE ELECTRICAL SUPPLY TO THE DRYER.**

## ***MONTHLY***

Grease the four (4) tumbler shaft pillow bearings with DC-44 (Dow Corning) grease or equivalent. DC-44 is a lithium grease that conforms to NLGI Grade 2 and has a temperature range of 40° F (4.4° C) to 400° F (204.4° C).

Empty the compressed air filter bowl and add oil to the compressed air lubricator bowl. Use a petroleum based non-detergent lightweight oil, SAE 10/150SSU, which will readily break up into a mist, such as Mobil DTE Light Oil or equivalent. **DO NOT USE SYNTHETIC OILS.**

## ***EVERY 90 DAYS***

Clean any lint accumulation on main blower wheel

Remove lint from around the tumbler drive motors and main blower (fan) motor

Main blower (fan) shaft bearings **must be** lubricated. Use a #3 grease or equivalent.

## ***EVERY 6 MONTHS***

Remove the gear oil in both tumbler drive shaft gear reducers. Replace with 1.4 liters (in each gear reducer) of Mobil Oil DTE HH5G (I.S.O. viscosity grade 460) or equivalent.

Main blower fan and drive motor belts **should be** examined. Cracked or seriously frayed belts **should be** replaced. Tighten belts when necessary.

Inspect and remove lint accumulation in customer furnished exhaust duct work system.

Open access door on top of tumbler and remove lint accumulation from tumbler brush.

**NOTE: THE ACCUMULATION OF LINT IN THE EXHAUST DUCT WORK CAN CREATE A POTENTIAL FIRE HAZARD.**

**NOTE:** When cleaning the dryer cabinets, avoid using harsh abrasive. A product intended for the cleaning of appliances is recommended.

# SECTION VI

## COMPONENT SYSTEM DESCRIPTIONS

### A. TUMBLER (BASKET) SUPPORT and DRIVE SYSTEM

**IMPORTANT:** Always keep the tumbler (basket) section of the dryer in an upright position when moving it.

#### 1. Tumbler (Basket)

The tumbler is made of five (5) 14-gauge stainless steel perforated panels, five (5) stainless steel lifting ribs, and two (2) outer tumbler rings. The tumbler (basket) is a completely welded assembly so the perforated panels are not removable.

#### 2. Tumbler (Basket) Support System

The tumbler (basket) sits on four (4) 11-inch diameter heavy-duty rubber roller wheels which supports and drives the tumbler. Two (2) rubber wheels are pressed into each of four (4) steel hubs. The steel hubs are fastened to the 2-inch diameter drive shafts by taper lock bushings. Each drive shaft is supported by two (2) 2-inch diameter heavy duty roller bearings. The position of the tumbler (basket) is adjusted by moving these bearings in or out with the four (4) bearings adjustment bolts.

AD - 464 TUMBLER DRIVE SYSTEM

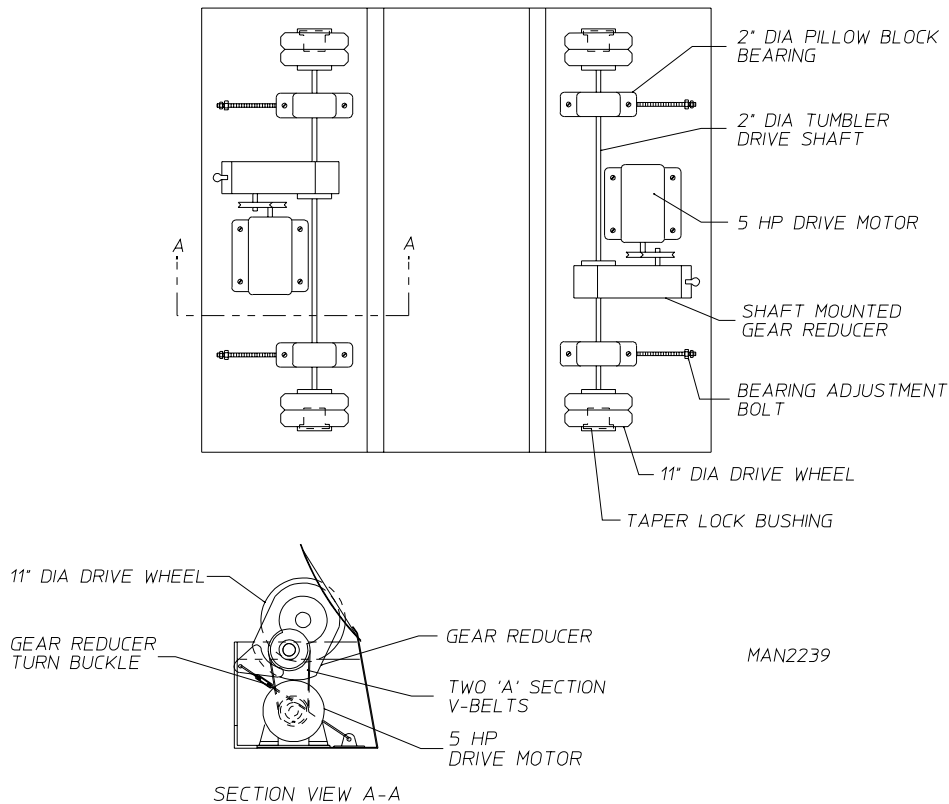

### 3. Tumbler and Basket Drive System

There are two (2) 5 HP tumbler drive motors. Each motor drives one of the 2-inch diameter tumbler drive shafts, and the motors spin simultaneously so that all four (4) sets drive wheels work together to spin the tumbler (basket).

Each motor is connected to the drive shaft by two (2) “A” section V-belts, driving a shaft-mounted (5.6 to 1 ratio) gear reducer. This produces a tumbler shaft speed of 200 RPM to 205 RPM and a tumbler (basket) speed of 31.5 RPM. Proper tension is maintained on the V-belts by tightening the gear reducer turnbuckle support. The oil in each gear reducer **must be** replaced every six (6) months by 1.4 liters of I.S.O. viscosity Grade 460 gear oil.

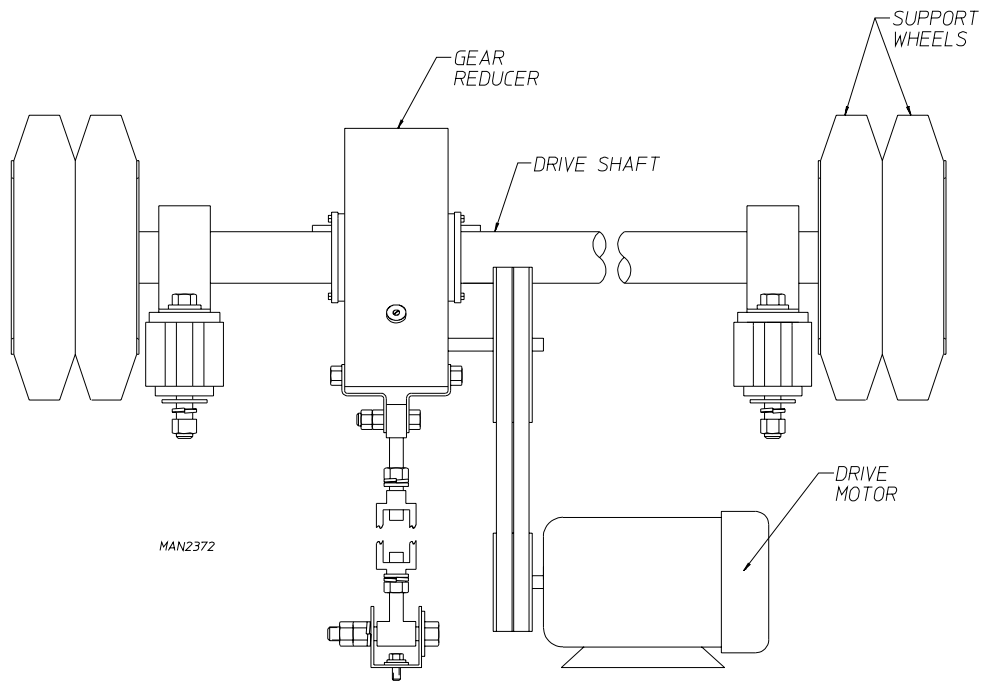

### 4. Servicing the Drive System

#### a. Removing a Drive Wheel

The drive wheels are removed through the front and back panels of the dryer, **not through the slides**. The front loading door and back loading door panels are hinged at the top. Remove the bolts holding these panels to tumbler section frame and swing the panel out. The two (2) 1/4-inch poly-flo tubes connected to the load door piston have to be removed to allow the panel to swing up far enough out to get access to the drive wheels. Likewise, the following electrical disconnections **must be** performed (refer to page 33).

1) Front Panel Electrical Connections:

a) Front Position Switch Disconnect Plug;

The front door position switch disconnect plug is located on the left side of the front doors. Disconnect this plug and feed the cable through the right hand side of the tumbler section.

b) Intake Temperature Probe Disconnect Plug;

The intake temperature probe disconnect plug is located in the burner and heater section, just above the 25 HP motor. Disconnect this plug and route through the hole located on the right of the front panel.

2) Rear Panel Electrical Connection Plug;

a) Rear Panel Controls Disconnect Plug;

The rear panel controls disconnect plug is located behind the rear panel controls. Disconnect this plug and feed through hole towards the left hand drum motor section.

b) Rear Door Position Switch Disconnect Plug;

The rear door position switch disconnect plug is located on the left side of the rear doors. Disconnect this plug and feed the cable through the right hand side of the tumbler section.

Put a block of wood under the tumbler; loosen and back out the tumbler shaft support bearings so that the drive wheel lines up with the large hole in the frame. The drive wheel taper lock bushing can now be loosened and removed through the hole in the frame, and the drive wheel pulled out of the dryer through this hole. Before backing out the tumbler shaft bearings mark their position on the frame to make reassembly easier.

5. Tumbler (Basket) Retaining Wheels

There are eight (8) 4-7/16" diameter retaining wheels which stabilize the tumbler's (basket's) position from front to back. Four (4) of these are mounted on the front panel of the dryer (two [2] on the left side and two [2] on the right side), and four (4) are mounted on the rear panel (two [2] on the left side and two [2] on the right side). Access to these wheels is obtained by removing the vertical front and rear panel covers.

## B. MAIN AIR BLOWER and HEAT RECLAIMER SYSTEM

The fan which moves the exhaust air through the ADS-464 dryer is a 22-inch diameter, squirrel cage wheel that is driven at 1,100 rpm by a 25 HP motor. This fan moves a maximum of 13,000 cfm (368 cmm) air through the dryer.

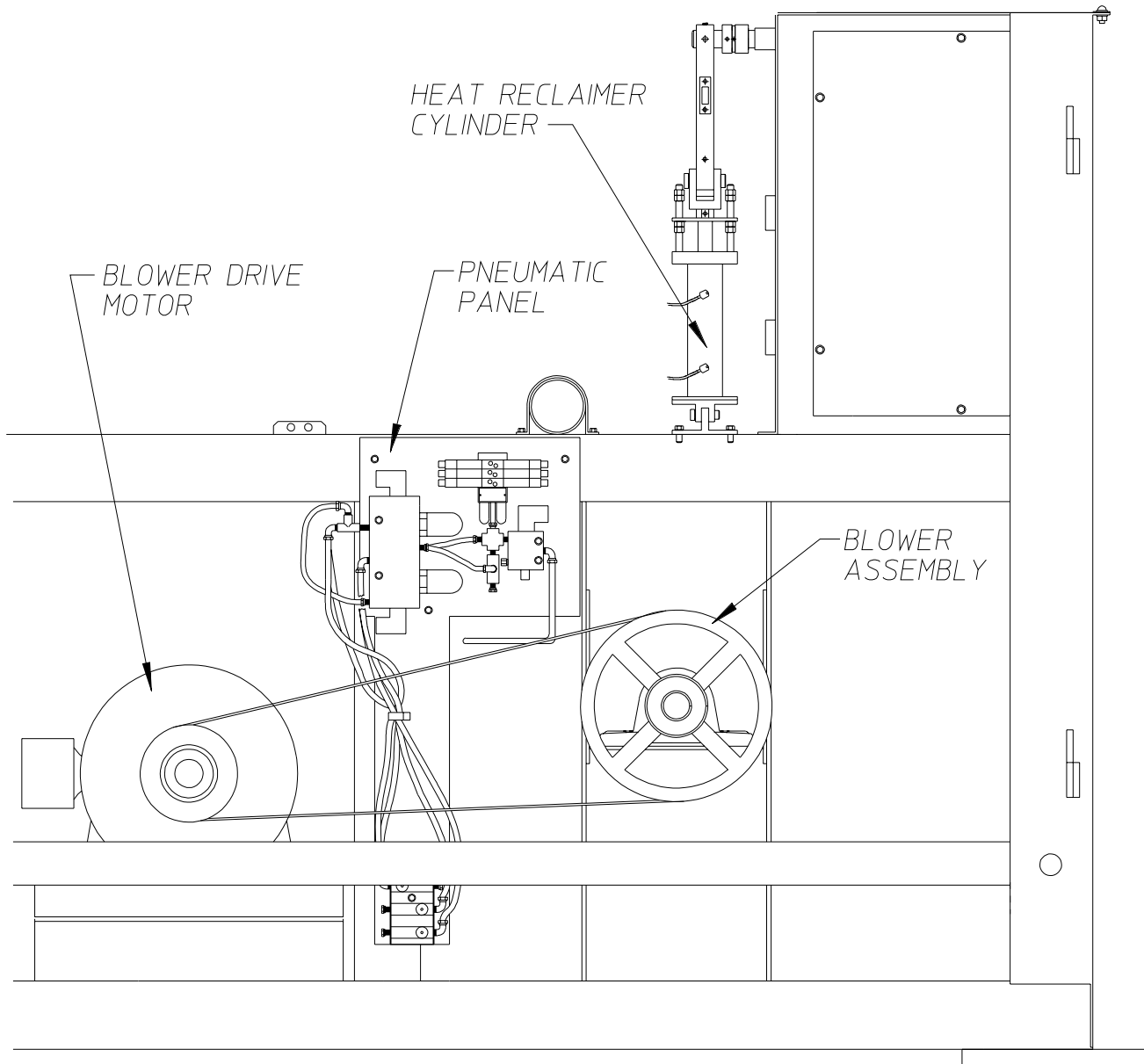

MAN2343

The dryer is equipped with a pneumatically operated heat reclaimer damper, which when opened, will recirculate approximately fifteen percent (15%) of the dryer's exhaust air.

The heat reclaimer damper is closed until ignition of flame has been established. Then, the damper piston is actuated, opening the dampers recirculating fifteen percent (15%) of the exhaust air back over the gas burner and into the tumbler (basket). The damper remains open for the rest of the drying cycle. On cool down, the damper closes, exhausting **ALL** of the 13,000 cfm which ensures a fast cool down of the load.

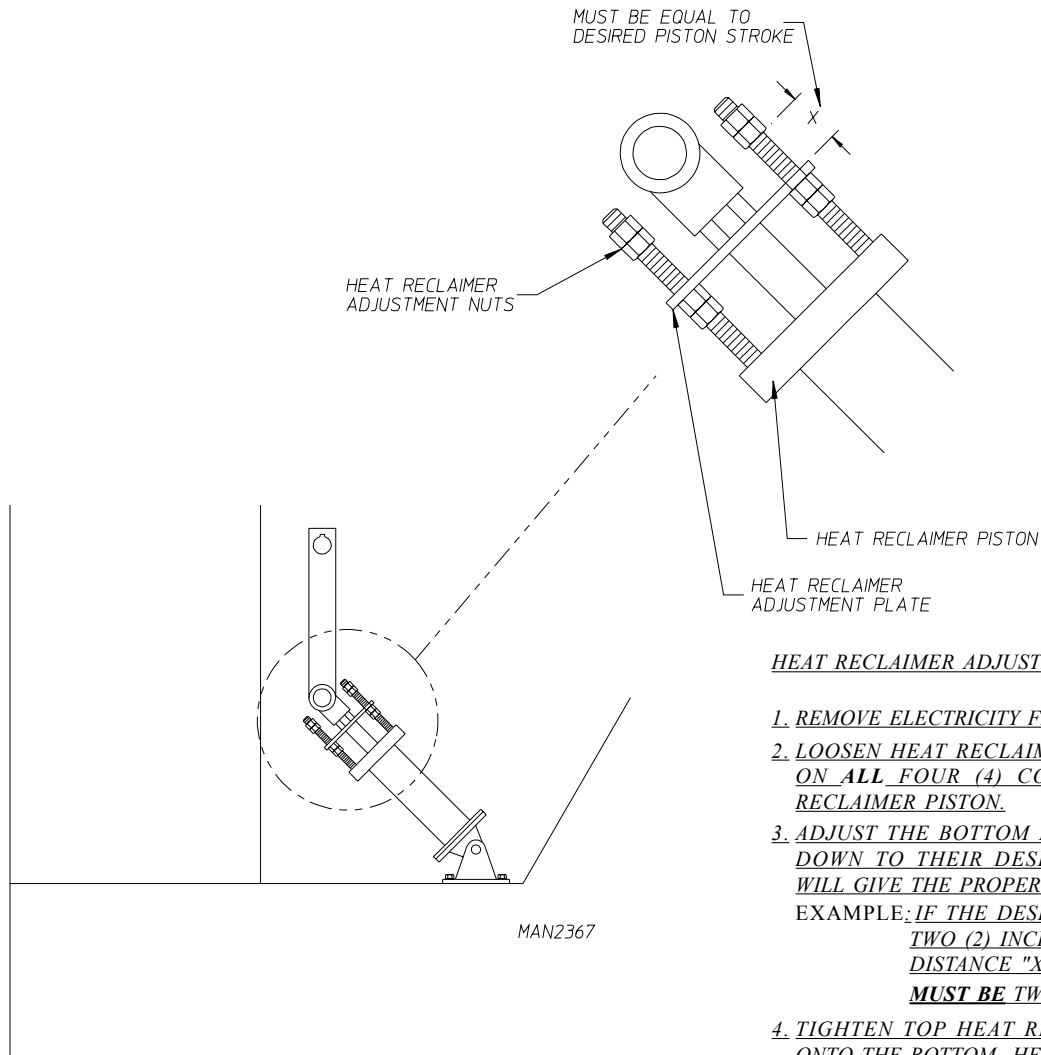

**HEAT RECLAIMER ADJUSTMENT**

1. REMOVE ELECTRICITY FROM THE UNIT.
2. LOOSEN HEAT RECLAIMER ADJUSTMENT NUTS ON ALL FOUR (4) CORNERS OF THE HEAT RECLAIMER PISTON.
3. ADJUST THE BOTTOM HEAT RECLAIMER NUTS DOWN TO THEIR DESIRED POSITION WHICH WILL GIVE THE PROPER PISTON STROKE.  
EXAMPLE: IF THE DESIRED PISTON STROKE IS TWO (2) INCHES (5.1 CM), THAN THE DISTANCE "X" IN THE ILLUSTRATION **MUST BE TWO (2) INCHES (5.1 CM).**
4. TIGHTEN TOP HEAT RECLAIMER NUTS DOWN ONTO THE BOTTOM HEAT RECLAIMER NUTS.

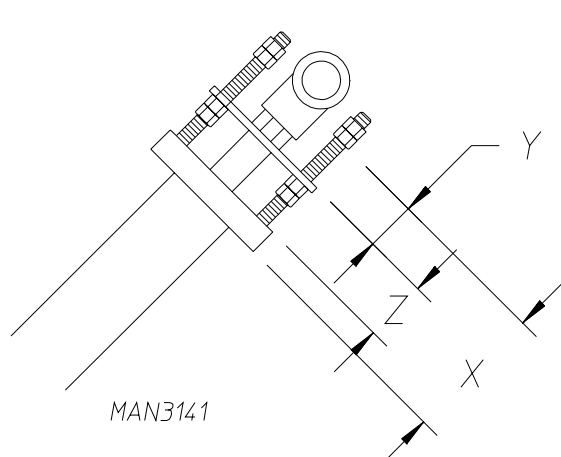

<b>HEAT RECLAIMER SETTINGS</b>			
<b>Z = 1-5/8"</b>			
<b>Y+Z=X</b>	<b>Y</b>	<b>%HR</b>	<b>Inches Reclaimed</b>
1-1/8"	1/2"	7.46	1-1/4"
2-5/8"	1"	15.67	2-5/8"
3-1/8"	1-1/2"	25.37	4-1/4"
3-5/8"	2"	34.32	5-3/4"
4-1/8"	2-1/2"	43.28	7-1/4"
4-5/8"	3"	50.74	8-1/2"
5-1/8"	3-1/2"	58.95	9-7/8"
<b>FULL OPEN 16-3/4"</b>			

## C. COMPRESSED AIR SYSTEM

**NOTE:** *Current Production* models use a Filter Regulator Assembly while *Past Production* models used a Filter/Regulator/Lubricator (FRL) Assembly. (Refer to the illustrations below.)

The compressed air system of the ADS-464 dryer consists of a number of pneumatic pistons located throughout the dryer, a Filter Regulator assembly, and pneumatic control panel.

### 1. Air Pistons

The pistons are actuated by solenoid and flow control valves that are under computer control. The pneumatic pistons are used to:

- Tilt the dryer for loading and unloading.
- Open and close load and unload doors.
- Operate heat reclaimer.
- Operate the cool down damper and the intake air damper.

### 2. Filter Regulator Assembly

The compressed air supply to the dryer is connected into the 3/8-inch F.P.T. fitting located on the rear corner of the lower heat console. This is connected to the Filter Regulator assembly which is located at the bottom rear of the lower heat console section.

The Filter Regulator assembly performs three (3) functions;

- a. The filter removes most solids and liquid particles from the compressed air stream and traps them in its bowl where this waste can be readily removed through the drain valve at the bottom of the bowl.

The filter bowl **should be** cleaned monthly.

CURRENT PRODUCTION

PAST PRODUCTION

- b. For dryers manufactured prior to February 26, 1997...

The lubricator injects a mist of oil into the compressed air stream so that the pistons and solenoid valves will function smoothly.

The oiling rate can be adjusted by turning the oil adjustment screw on top of the lubricator.

Oil is added to the bowl **should be** refilled on a monthly basis with any petroleum-based, non-detergent lightweight oil (SAE 10/150 SSU) which will readily break up into a mist. **DO NOT USE SYNTHETIC OIL or OILS CONTAINING ADDITIVES or SOLVENTS.**

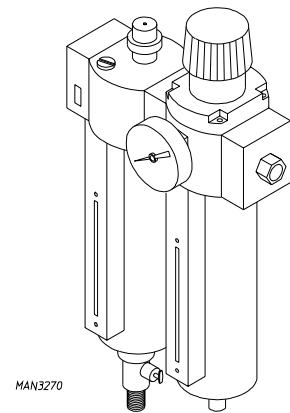
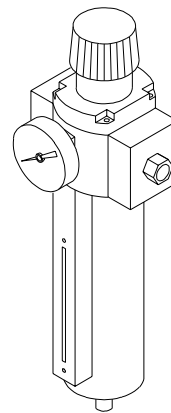

- c. The regulator will maintain a nearly constant outlet air pressure of 80 PSI so that the dryer's air pistons will function normally despite upstream air pressure variation.

**NOTE:** Dryers manufactured as of February 26, 1997 have their pneumatic components pre-lubricated.



### 3. Pneumatic Control Panel

The pneumatic control panel of a 2-Way Tilt dryer has two (2) tilting solenoid valves, one to control the front set of tilting pistons and a second to control the rear set of tilting pistons. A 1-Way Tilt dryer has only one (1) tilting solenoid valve.

Each valve has five (5) 1/2-inch F.P.T. ports and two (2) electric solenoids, one on each side of the valve.

To tilt the dryer back, a 120 volt signal is applied to the front pistons solenoid connector #S5, and no voltage is applied to the solenoid connector #S8. The internal spool in the valve will move and 80 PSI of air will enter the bottom port of the front tilting pistons, extending the front tilting piston rods and tilting the dryer back for loading. The top piston ports are bled to the atmosphere. To level the dryer after loading, the voltage signals are reversed. No voltage is applied to the “S5” solenoid, and 120 volts are applied to the “S8” solenoid. The valve spool will now move so that 80 PSI of air is applied at the top piston ports, while the bottom piston ports are bled to the atmosphere. The piston rods will now retract, leveling the dryer. On 2-Way Tilt dryers, the rear tilting piston solenoid valve acts in the same manner.

The tilting piston valves are 3-position valves. This means that, if no voltage is applied to both positions “S5” and “S8” **ALL** five (5) valve ports are blocked. If the dryer is tilting or leveling and power to the dryer is shut off, the pistons will lock in position, holding the dryer in a partially tilted position.

The dryer can be made to tilt faster or slower by adjusting the pistons 3/8” flow control valves which are located on the pneumatic control panel.

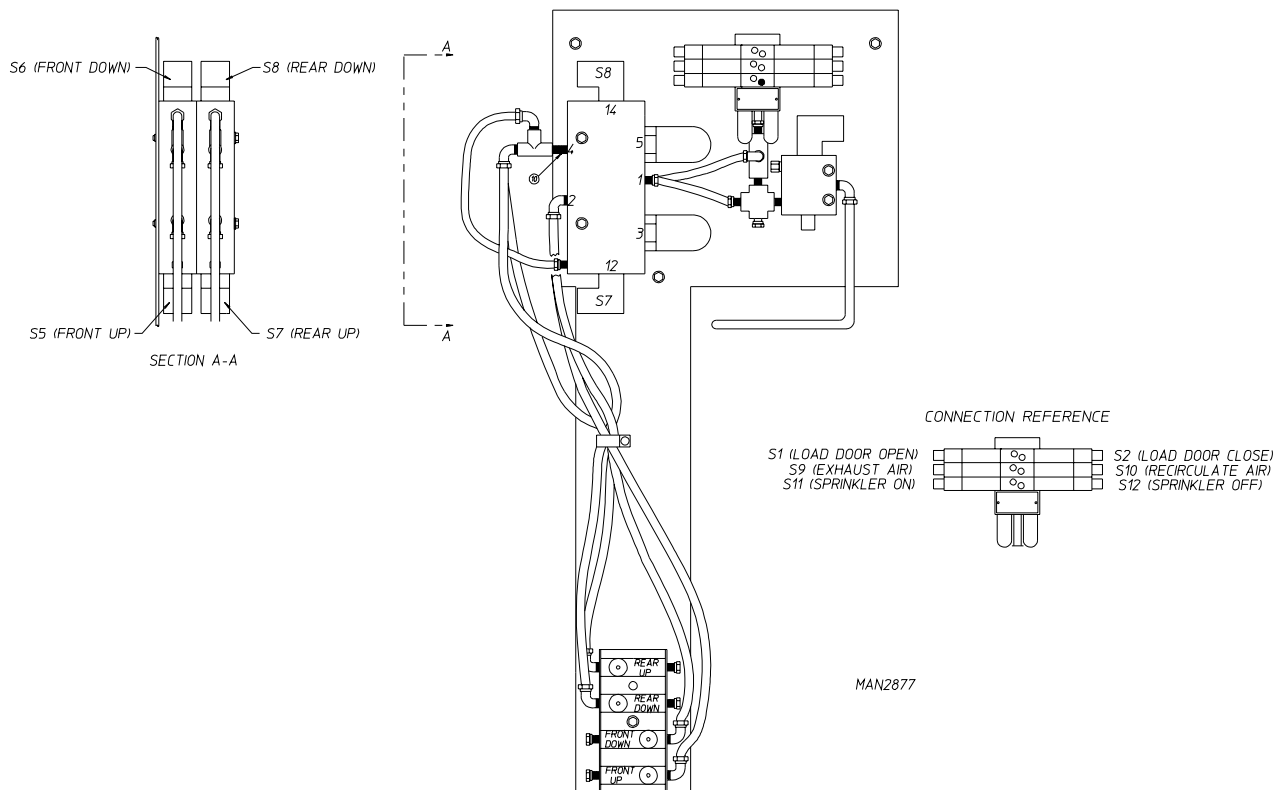

#### 4. Internal and External Pilot Air Supply

On two-way tilt dryers, a pneumatic safety circuit is incorporated to prevent both front and rear tilting pistons from extending their rods at the same time. When 120 volts is supplied to the “S5” side of the front tilting piston solenoid valve coil, the round internal spool in the core of the solenoid will move, allowing 80 PSI air to flow into the bottom ports of the front tilting pistons, while the top ports of these pistons are bled to the atmosphere. In addition to this 120 volt electrical signal, the spool also requires a 30 PSI supply of compressed air to change its position. This pilot air can either be supplied internally, tapped off the 80 PSI air supply connected to port no. 1 through holes in the body of the solenoid valve or it can be supplied externally through the 1/8-inch F.P.T. connection located on either end of the solenoid valve. If no pilot air is supplied to the solenoid valve. Then the spool **cannot** move, even with voltage supplied to the solenoid valve coil.

This can be used to prevent both sets of tilting pistons from extending their rods at the same time. When the front tilting piston rods are extended, 80 PSI air is connected to the bottom piston ports, while the top piston ports are bled to the atmosphere. So, by tapping the external pilot air supply to the rear tilting rods are extended, then there is no pilot pressure available to the rear tilting piston solenoid valve so that its spool **cannot** move and the rear tilting piston rods **cannot** extend if a 120 volt signal is sent to its “12” side solenoid valve coil.

The external pilot air supply to the front tilting piston is tapped off the rear tilting piston top port air line so that whenever the rear piston rods are extended, there is no pilot air supplied to the front tilting piston solenoid valve and the front tilting piston rods cannot extend. On the solenoid valve supplied on the dryer, the “12” side valve is externally piloted, while “14” side valve is internally piloted.

A valve can easily be checked for internal or external piloting by removing the two (2) screws which hold the solenoid operator onto the valve. For an internal pilot air to be supplied to the valve spool. For an external pilot, the solid sealing disc **must be** positioned on top of the internal port.

#### 5. Loading Doors and Heat Reclaimer, Cool Down and Intake Air Damper

These solenoid valves are located in the 6-station manifold block on the pneumatic control panel. Each door piston is controlled by two (2) 2-port/2-position solenoid valve. The heat reclaimer is controlled by one (1) 2-port/2-position solenoid valves.

The three (3) pistons that control the heat reclaimer damper, cool down damper, and intake air damper are controlled by a single 3-way double acting solenoid valve.

To open the front loading door, a 120 volt signal is applied to “S1,” the coil of the valve that supplies air to the load door or the heat reclaimer’s bottom port. The valve will open, and 80 PSI of air is supplied to the bottom port of the piston. The piston rod will extend, and the door will open. No voltage is applied to “S2,” the coil of the valve that controls the air supply to the door pistons top port so that this line is bled to the atmosphere.

To close the front loading door or heat reclaimer damper, the voltage signals are reversed, and the loading door will close.

## D. SAFETY DEVICES

The ADS-464 dryer is equipped with numerous safety devices to ensure that the dryer operates safely. The chart on the following page ([page 40](#)) lists each device with its location, function, computer display message, and result of tripping.

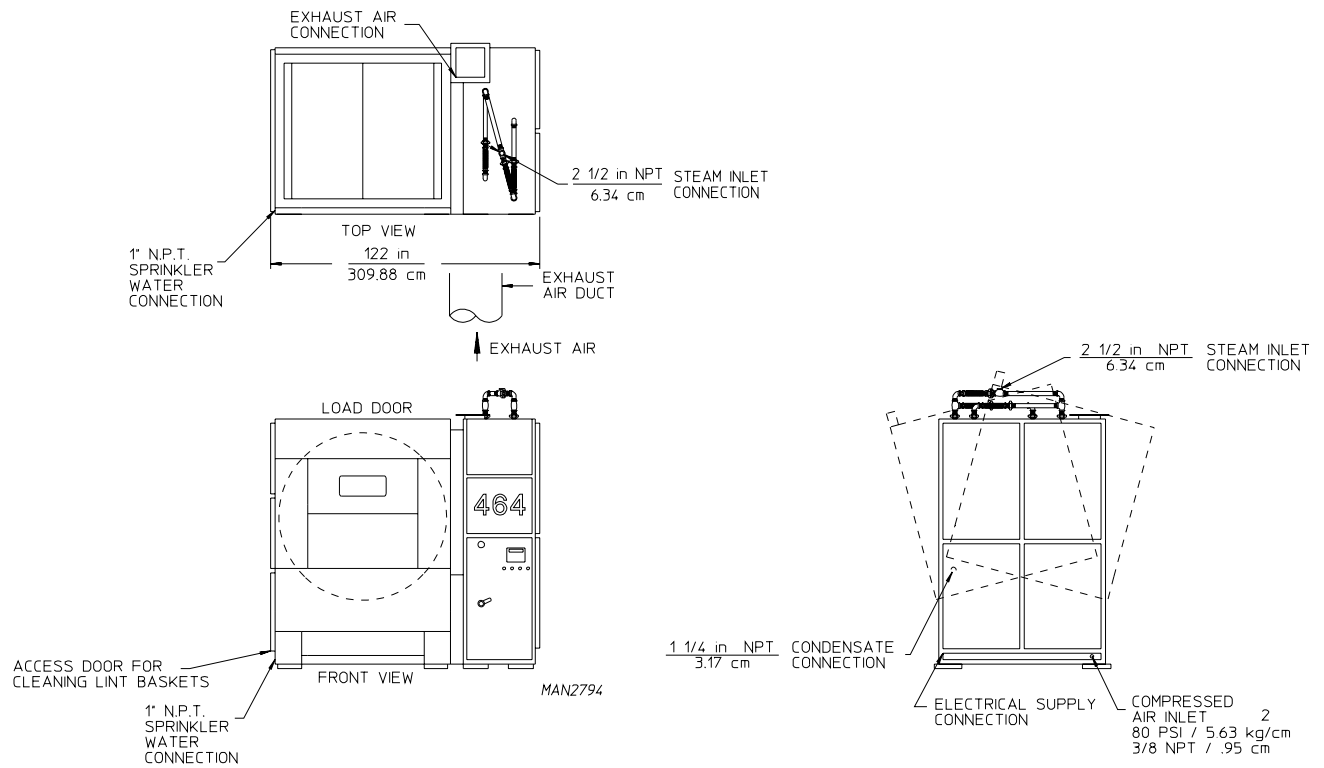

SAFETY DEVICES	LOCATION	FUNCTION	COMPUTER DISPLAY MESSAGE	RESULT OF TRIPPING
LOAD DOOR SWITCH	LEFT SIDE OF LOAD DOOR	INSURES DRYER LOAD DOOR ARE CLOSED	"DOOR OPEN"	DRYER WILL NOT RUN
UNLOAD DOOR SWITCH (TWO DOOR UNIT ONLY)	RIGHT SIDE OF UNLOAD DOOR	INSURES DRYER UNLOAD DOORS ARE CLOSED	"DOOR OPEN"	DRYER WILL NOT RUN
TILTING SWITCHES	TOP LEFT SIDE OF BASE MODULE	INSURES DRYER IS LEVEL	"LEVEL FAULT"	DRYER WILL NOT RUN
DRUM ROTATION SENSOR	LEFT SIDE OF TUMBLER SECTION	INSURES TUMBLER IS ROTATING	"DRUM FAULT"	STOPS HEAT ONLY
LINT CHAMBER AIR PRESSURE SWITCH	CENTER OF HEAT CONSOLE	INSURES PROPER AIR FLOW THROUGH DRYER	"AIRFLOW FAULT"	STOPS HEAT ONLY
BURNER FAN AIR FLOW SWITCH (GAS DRYERS ONLY)	CENTER OF HEAT CONSOLE	INSURES PROPER COMBUSTION AIR FLOW INTO THE BURNER BOX	"HEATER FAULT"	STOPS HEAT ONLY
HI/LO GAS PRESSURE SWITCH (GAS DRYERS ONLY)	LOWER LEFT OF HEAT CONSOLE SECTION	INSURES PROPER GAS SUPPLY PRESSURE FOR ADEQUATE IGNITION	"GAS SUPPLY FAULT"	STOPS HEAT ONLY
HEAT RECLAIMER DAMPER SWITCH	RIGHT SIDE OF HEAT CONSOLE	INSURES THAT THE HEAT RECLAIMER IS EITHER OPENED OR CLOSED	INPUT LED #13 OF THE PLC IS OFF	NONE
HEAT CONSOLE DOOR ACCESS DOOR SWITCH	INSIDE HEAT CONSOLE	INSURES THAT ACCESS DOORS ARE CLOSED	"DOOR OPEN"	DRYER WILL NOT RUN
EXHAUST AIR TEMP CONTROL SENSOR	INSIDE BURNER SECTION DUCT	MONITORS TUMBLER EXHAUST AIR TEMP	"EXHAUST DSFL"	STOPS HEAT ONLY
EXHAUST AIR HI TEMP CONTROL SENSOR	INSIDE EXHAUST DUCT	MONITORS TUMBLER EXHAUST AND AIR TEMP	"HI-TEMP FAULT"	STOPS HEAT ONLY
INTAKE AIR TEMP CONTROL SENSOR (OPTIONAL)	TOP RIGHT OF TUMBLER SECTION	MONITORS TUMBLER AIR INTAKE TEMP	"INTAKE DSFL"	STOPS HEAT ONLY
INTAKE AIR TEMP CONTROL SENSOR	TOP RIGHT OF TUMBLER SECTION	MONITORS TUMBLER AIR INTAKE TEMP	"HI-TEMP FAULT"	STOPS HEAT ONLY
BURNER HI-LIMIT SAFETY SENSOR	TOP OF BURNER SECTION	MONITORS AIR TEMP ABOVE THE BURNER BOX	"HI-TEMP FAULT"	STOPS HEAT ONLY
SPRINKLER CONTROL SAFETY SENSOR	TOP RIGHT OF TUMBLER SECTION	OPEN SPRINKLER SYSTEM WATER VALVE ON HI-TEMP CONDITION	ORANGE SPRINKLER PILOT LIGHT COMES ON. ALARM HORN SOUNDS	OPENS THE SPRINKLER WATER VALVE AND POWER DOWN THE WHOLE DRYER
LINT DRAWER SWITCHES	ABOVE LINT DRAWER HANDLES	DISABLES MACHINE WHEN DRAWERS ARE OPEN OR IF DRAWERS HAVE NOT BEEN CLEANED IN LAST FIVE LOADS.	LINT DRAWER	DRYER WILL NOT RUN

# SECTION VII

## SERVICE/PARTS INFORMATION

### A. SERVICE

1. Service **must be** performed by a qualified trained technician, service agency or gas supplier. If service is required, contact the distributor from whom the **ADC** equipment was purchased. If the distributor **cannot** be contacted or is unknown, contact the **ADC Service Department** for a distributor in your area.

**NOTE:** When contacting the **ADC Service Department**, be sure to give them the correct **model number and serial number** so your inquiry is handled in an expeditious manner.

### B. PARTS

1. Replacement parts **should be** purchased from the distributor from whom the **ADC** equipment was purchased. If the distributor **cannot** be contacted or is unknown, contact the **ADC Parts Department** for a distributor in your area. Parts may also be purchased directly from the factory by calling the **ADC Parts Department** at (508) 678-9000 or you may FAX in your order at (508) 678-9447.

**NOTE:** When ordering replacement parts from the **ADC dealer** or the **ADC factory** be sure to give them the correct **model number and serial number** so that your parts order can be processed in an expeditious manner.

# SECTION VIII

## WARRANTY INFORMATION

### A. RETURNING WARRANTY CARDS

1. Before any dryer leaves the **ADC** factory test area, a warranty card (**ADC** Part No. 112254) is placed on the back side of the main door glass. These warranty cards are intended to serve the customer where we record the individual installation date and warranty information to better serve you, if you file a warranty claim.
  - a. If a warranty card (**ADC** Part No. 112254) did not come with your dryer, contact the **ADC** Warranty Department or the **ADC** Service Department at (508) 678-9000.

### B. WARRANTY

For a copy of the **ADC** commercial warranty covering your particular dryers, contact the **ADC** distributor from whom you purchased the equipment and request dryer warranty form **ADC** Part No. 450199. If the distributor **cannot** be contacted or is unknown, warranty information can be obtained from the factory by contacting the **ADC** Warranty Department at (508) 678-9000.

**NOTE:** Whenever contacting the **ADC** factory for warranty or warranty information, be sure to have the dryer's **model number** and **serial number** available so that your inquiry can be handled in an expeditious manner.

### C. RETURNING WARRANTY PARTS

**ALL** dryer or parts warranty claims or inquiries **should be** addressed to the **ADC** Warranty Parts Department. To expedite processing, the following procedures **must be** followed:

1. No parts are to be returned to **ADC** without prior written authorization ("Return Material Authorization") from the factory.

**NOTE:** An R.M.A. ("Return Material Authorization") is valid for only sixty (60) days from date of issue.

- a. The R.M.A. issued by the factory, as well as any other correspondence pertaining to the returned part(s), **must be** included inside the package with the failed merchandise.
2. Each part **must be** tagged with the following information:
    - a. **Model number** and **serial number** of the dryer from which part was removed.
    - b. Nature of failure (be specific).
    - c. Date of dryer installation.

d. Date of part failure.

e. Specify whether the parts being returned is for a replacement, a credit, or a refund.

**NOTE:** If a part is marked for a credit or a refund, the invoice number covering the purchase of the replacement part **must be** provided.

**NOTE:** Warranty tags (ADC Part No. 450064) are available at "no charge" from ADC upon request.

3. The company returning the parts must clearly note the complete company name and address on the outside of the package.

4. **ALL** returns **must be** properly packaged to insure that they are not damaged in transit. *Damage claims are the responsibility of the shipper.*

**IMPORTANT:** No replacements, credits or refunds will be issued for merchandise damaged in transit.

5. **ALL** returns **should be** shipped to the ADC factory in such a manner that they are insured and a proof of delivery can be obtained by the sender.

6. **Shipping charges are not the responsibility of ADC. ALL returns should be "prepaid" to the factory. Any "C.O.D." or "COLLECT" returns will not be accepted.**

**IMPORTANT:** No replacements, credits, or refunds will be issued if the claim **cannot** be processed due to insufficient information. The party filing the claim will be notified in writing, either by "FAX" or "CERTIFIED MAIL - Return Receipt Requested," as to the information necessary to process claim. If a reply is not received by the ADC Warranty Department within thirty (30) days from the FAX/letter date, then no replacement, credit, or refund will be issued, and the merchandise **will be discarded.**

# SECTION IX

## TROUBLESHOOTING

**IMPORTANT:** YOU MUST DISCONNECT and LOCKOUT THE ELECTRICAL SUPPLY and THE STEAM SUPPLY BEFORE ANY COVERS or GUARDS ARE REMOVED FROM THE MACHINE TO ALLOW ACCESS FOR CLEANING, ADJUSTING, INSTALLATION OR TESTING OF ANY EQUIPMENT per OSHA (Occupational Safety and Health Administration) STANDARDS.

The information provided will help isolate the most probable components associated with the difficulty described. The experienced technician realizes, however, that a loose connection, or broken or shorted wire may be at fault where electrical components are concerned. **DO NOT** necessarily suspect the component itself. Electrical parts **should always be** check for failure before being returned to the factory.

**IMPORTANT:** When replacing blown fuses, the replacement *must be* of the exact rating as the fuses being replaced. The information provided *should not* be misconstrued as a handbook for use by an untrained person in making repairs.

**WARNING:** ALL SERVICE and TROUBLESHOOTING **SHOULD BE** PERFORMED BY A QUALIFIED PROFESSIONAL or SERVICE AGENCY.

**WARNING:** WHILE MAKING REPAIRS, OBSERVE ALL SAFETY PRECAUTIONS DISPLAYED ON THE DRYER or SPECIFIED IN THIS MANUAL.

The following information assumes that the reader has familiarized himself with the introduction to this manual, understands the ADS-464 dryer operation, and has knowledge of the programming features of the dryer.

<b>TROUBLESHOOTING TABLE OF CONTENTS</b>	<b>PAGE NUMBER</b>
<b>A.</b> POWER MALFUNCTIONS	45
<b>B.</b> TUMBLER (BASKET) ELECTRICAL MALFUNCTIONS	56
<b>C.</b> BASE SECTION ELECTRICAL MALFUNCTIONS	64
<b>D.</b> PENDENT CONTROL MALFUNCTIONS	68
<b>E.</b> TEMPERATURE SENSING	71
<b>F.</b> MOTORS	74
<b>G.</b> PLC (PROGRAMMABLE LOGIC CONTROLLER) MESSAGES	76



## A. POWER MALFUNCTIONS

### 1. Main Disconnect Will Not Turn On

#### a. *PROBABLE CAUSES*;

- 1a) Sprinkler isolated power source “OFF” or disabled.
- 2a) OL12 tripped or sprinkler circuit defective.
- 3a) Sprinkler activated.
- 4a) Sprinkler will not reset.

#### b. *POSSIBLE SOLUTIONS*;

1b) Verify “**RED**” “Sprinkler Power” on main panel to be illuminated.

- If “ON” go to **paragraph #3b below**
- If “NOT ON” verify isolated sprinkler power source to the dryer

Check sprinkler supply voltage at TB1 **Pin #4 and Pin #5**

- If “OK” go to **paragraph #2b below**
- If none, check incoming line voltage
- If none, check fuse disconnect switch

2b) Check if OL12 has tripped.

- If “OK” go to **paragraph #3b below**
- If tripped, check sprinkler circuit, then reset and test.

3b) Check if sprinkler is activated...is the “SPRINKLER RESET” button “lit”?

- If “YES,” press “SPRINKLER RESET”

Does the sprinkler reset?

- If “YES,” attempt to turn “ON” the main disconnect again
- If “NO” go to **paragraph #4b below and on page 46**

4b) Sprinkler will not reset, verify that the sprinkler hi-limit has not tripped. (“**GREEN**” light is off.)

- If it has not tripped, check setting to be 550° F (273° C) and verify that the sprinkler RTD (Resistive Temperature Device) is connected and has 100 ohms (100  $\Omega$ ) at 32° F (0° C)/109 ohms (109  $\Omega$ ) at 75° F (24° C)

- If RTD (Resistive Temperature Device) probe is defective, replace the probe.

**NOTE:** If ALL systems check out fine, call the **ADC** Service Department at (508) 678-9000.

## 2. No Control Power (“**BLUE**” Light Off)

### a. *PROBABLE CAUSES;*

- 1a) Line voltage from main fused disconnected.
- 2a) Main disconnect on the ADS-464 is turned off.
- 3a) OL11 (overload #11) tripped.
- 4a) Fuse #1 is blown.

### b. *POSSIBLE SOLUTIONS;*

#### 1b) Verify main line voltage to ADS-464

- If line voltage is present go to **paragraph #2b below**
- If line voltage is not present check fused disconnect and re-test

#### 2b) Attempt to turn the ADS-464 main power handle to the “ON” position

- If the switch does not engage, verify that sprinkler power is “ON” (“**RED**” light on main door)
- If “NO,” refer to **paragraph #1b above**

#### 3) Open main enclosure and verify that OL11 has not tripped

- If “YES,” check circuit, restart and test
- If “NO.” go to **section #3 on page 47**
- Verify that fuse #1 has not blown, check that the “**RED**” L.E.D. indicator is off.
- If “ON.” (fuse block L.E.D. “ON”), check circuit, replace fuse and test.

3. Machine Main Power Shuts Down (“**BLUE**” Indicator Off)

a. *PROBABLE CAUSES*;

- 1a) Sprinkler activated.
- 2a) OL12 (overload #12) tripped.
- 3a) “UNDER VOLTAGE FEATURE” of main disconnect has tripped.
- 4a) Sprinkler circuit defective.

b. *POSSIBLE SOLUTIONS*;

- 1b) Check if the sprinkler is activated, is “SPRINKLER RESET” button lit? Is the sprinkler alarm horn “ON”? Does the sprinkler water valve have its “ON” indicator extended?
  - If yes, it indicates that the sprinkler circuit has shutdown the Main Disconnect, press the lit “SPRINKLER RESET” button, does it reset?
  - If “NO,” go to **paragraph 2b below**
- 2b) Verify that OL12 (overload #12) has not tripped
  - If “YES,” check circuit, reset OL12, and test
  - If “NO,” go to **paragraph 3b below**
- 3b) The main disconnect has an “UNDER VOLTAGE DROP OUT FEATURE.” This feature requires that 110 VAC be present to engage the disconnect switch. If 110 VAC is removed from **Pin #51 and Pin #52** on the switch, the disconnect will drop out automatically. Verify that 110 volts AC is supplied to the disconnect and that wires are secure.
  - If 110 VAC is present, the disconnect may be defective
  - If 110 VAC is not present go to the **beginning of section 3 at the top of the page**

4. Sprinkler circuit may be defective.

The following information will first describe the sprinkler circuit components and then provide a circuit description. Please refer to the ADS-464 ladder diagram (which is supplied with the machine) as the following is described.

### SPRINKLER CIRCUIT COMPONENTS

- OL12 (overload #12) is a 1.6-amp magnetic and thermal overload device set 1-amp. Its function is to protect and the line voltage of the sprinkler circuit.
- T1 is a control transformer whose primary depends on the system line voltage (i.e., 208 VAC, 240 VAC, 380 VAC, 416 VAC, and 480 VAC). Refer to system’s nameplate. Its secondary is 110 volts AC.
- L3 is a “**RED**” indicator installed on the electrical enclosure door. Its function is to indicate the presence of 110 VAC to the sprinkler system.
- Sprinkler High Limit Controller (SHLC) - Its function is to monitor a preset hi-limit temperature (which is currently set to 550° F [287.8° C]) and to control the activation of the “WATER SPRINKLER” circuit.
- SHLC’s (Sprinkler High Limit Controller’s) temperature information is derived from the RTD #4 (Resistive Temperature Device #4), a resistive sensor located on the top right hand side of the tumbler (basket) section. Its exact location is in proximity of the intake and hi-limit temperature probe.

**IMPORTANT:** An open RTD (Resistive Temperature Device) probe or disconnecting the probe under power will cause the sprinkler to active.

- ALL ADS-464 RTD (Resistive Temperature Device) probes are rated for 1,100° F (593.3° C).
- SHCL #2 (Sprinkler High Limit Controller #2) contacts (alarm and set point) are configured in the normally open state.
- #2CR (#2 control relay) and #3CR (#3 control relay) are relay coils that are energized in a logical manner for circuit control. The following are their associated relay contacts information.

<b>RELAY</b>	<b>NORMALLY CLOSED CONTACTS</b>	<b>NORMALLY OPEN RELAYS</b>
2CR	2CRB	2CR1
3CR	3CRB	NOT USED

- S11 and S12 are the actual electrical solenoid connections that turn on or shut off the air actuated water valve. The electrical connections for S11 and S12 are located in the solenoid junction box in the burner section of the ADS-464
  - S11 = Sprinkler ON
  - S12 = Sprinkler OFF

**IMPORTANT:** For proper sprinkler and dryer operation, sprinkler *must be* powered by a “separate or dedicated” single-phase (1Ø) multi-wire branch circuit at dryer’s nameplate voltage.

- L4 (light #4) is an “**AMBER**” light associated with PB #10 (push button #10), the “SPRINKLER RESET” button. These items are located on the electrical enclosure’s front panel. L4’s function is to give a visual indication that the sprinkler function is asserted and that the pneumatically activated water valve is open.
- The air actuated water valve also has a visual indicator to show its current state. Notice a “**RED**” button on the rear side of the valve.
  - IN = Valve CLOSED
  - OUT = Valve OPEN

**NOTE:** The sprinkler water inlet line has a hand operated gate valve and *must be* open for water to flow. It is suggested that this manual valve be closed when working on the dryer, to avoid problems caused by false tripping of the sprinkler circuit.

**IMPORTANT:** BE SURE TO TURN ON THE VALVE WHEN THE WORK IS COMPLETE.

- PB #10 (push button #10) “SPRINKLER RESET” button is for resetting the sprinkler circuit once the temperature in the tumbler (basket) has dropped below its preset trip temperature.

**NOTE:** Pressing the “SPRINKLER RESET” button before the tumbler (basket) temperature has dropped below its trip temperature will momentarily stop the water flow. However, the water flow will resume once the button is released.

- UV is the “UNDER VOLTAGE” detection coil of the ADS-464 MAIN DISCONNECT switch, DISC #1. It is this device that controls the automatic POWER DOWN of the dryer when the sprinkler is activated.

### SPRINKLER CIRCUIT DESCRIPTION

The following information assumes that the reader has read the sprinkler component descriptions and is following the ADS-464 Ladder Diagram of the Sprinkler Circuit.

- STATE 1 - The tumbler (basket) temperature is “BELOW” SHLC (Sprinkler High Limit Controller) preset trip value. When power is applied to SHLC:
  - SHLC set point will close.
  - SHLC alarm will open.
  - UV (under voltage) will engage.

**SUMMARY:** With UV (under voltage control of the main disconnect) energized, the ADS-464 main switch may be turned on.

- STATE 2 - The tumbler (basket) temperature has risen “ABOVE” SHLC (Sprinkler High Limit Controller) preset trip value. With power is applied to SHLC:
  - SHLC set point will open
  - SHLC alarm will close
  - #2CR (#2 control relay) will become energized
  - S11 will be energized (sprinkler valve open)
  - L4 (light #4) will be energized (sprinkler valve open)
  - SP2 will activate alarm horn.
  - #2CR “B” will open.
  - SHLC alarm relay will toggle, causing the alarm contact to close and activate 2CR’s (control relay’s) coil. This action will;
    - Open 2CR “B” causing UV, the “under voltage” trip feature of the ADS-464’s main disconnect to shut down the “MAIN POWER” to the dryer.
    - Latch 2CR “A” “ON” to eliminate any automatic reset of the sprinkler solenoid
    - Energize the “SPRINKLER ON” air solenoid
    - Illuminate the “SPRINKLER RESET BUTTON”
    - Sound sprinkler alarm horn

**NOTE:** The sprinkler circuit will not reset until the ADS-464’s temperature is below the sprinkler hi-limit controller setting.

- STATE 3 - The tumbler (basket) temperature is still “ABOVE” SHLC (Sprinkler High Limit Controller) preset value and PB #10 (push button #10) “Sprinkler Reset” has been pushed and held “IN.” With power still applied to the SHLC:
  - #3CR will energize
  - S12 will energize
  - #3CR “A” will open
  - #2CR will de-energize
  - L4 will go off
  - SP2 will go off

**SUMMARY:** #3CR’s (#3 control relay’s) coil will energize causing:

- 3CR “A” will open and remove power from 2CR, S11, L4 and SP2
- S12 “sprinkler off” air solenoid will activate turning off the actuated sprinkler valve

**IMPORTANT:** If the tumbler (basket) temperature is still “ABOVE” SHLC (Sprinkler High Limit Controller) preset value, and the “SPRINKLER RESET” button is released the water valve will open again. (Refer to **STATE 2 above**.) If the tumbler (basket) temperature is “BELOW” the SHLC preset value when the “SPRINKLER RESET” button is released, the water valve will remain closed. (Refer to **STATE 1 on page 49**.)

4. Front Panel “**BLUE**” Light and “**RED**” Light “ON”

ADS-464 “ON” button does respond ...

a. PROBABLE CAUSES;

1a) **EMERGENCY STOP** (E-STOP) BUTTONS 1, 2, and 3.

b. POSSIBLE SOLUTIONS;

1b) Verify that **ALL EMERGENCY STOP** (E-Stop) buttons are pushed in.

- **EMERGENCY STOP 1** - main enclosed door
- **EMERGENCY STOP 2** - pendent control
- **EMERGENCY STOP 3** - rear control panel (2-door models only)
- If **ALL EMERGENCY STOP** (E-Stop) buttons are “disengaged,” press “ON” located on the main enclosure door.
- If “NO,” go to **section 3 on page 47**

Does the system “**GREEN**” “ON” light illuminate?

- If not, check the **EMERGENCY STOP** (E-Stop) and drying system “ON/OFF” circuits. (Refer to ladder diagram.)

5. Front Panel “**BLUE**” (main panel) light, “**RED**” (sprinkler power) light, and “**GREEN**” (control power) light “ON”

The system has one or more of the following symptoms;

- OPERATOR INTERFACE TERMINAL - no display or displays “LINE FAULT” message
- PROGRAMMABLE LOGIC CONTROLLER (PLC) - no indicator lights “ON”
- CONVENIENCE OUTLET - no power
- HI-LIMIT CONTROLLERS (HLS1 and HLS2) - no display

a. *PROBABLE CAUSES*;

1a) Fuse 7 -- PLC (Programmable Logic Controller) power  
Fuse 8 -- 24 volt DC power  
Fuse 9 -- convenience outlet  
Fuse 10 - hi-limit controller power

2a) Malfunctioning PLC (Programmable Logic Controller).

- 3a) Malfunctioning operator interface terminal or communications cable.
- 4a) Malfunctioning 24 volt DC power supply.
- 5a) Malfunctioning hi-limit temperature controller.

b. *POSSIBLE SOLUTIONS;*

- 1b) Verify that fuses 7, 8, 9, and 10 are good.

Check that **ALL** fuse holder L.E.D. (light emitting diode) indicators are not lit

- If **ALL** fuses are good, go to **paragraph #2b below, paragraph #3b below, paragraph #4b below, or paragraph #5b below**
- If a fuse is bad, check the corresponding circuit, replace the fuse and test

- 2b) Malfunctioning PLC (Programmable Logic Controller).

- If PLC power is off, a “LINE FAULT MESSAGE” will be displayed on the operator interface terminal.

**NOTE:** Call the ADC Service Department at (508) 678-9000.

- 3b) Malfunctioning operator interface terminal.

- Check power supply voltage to the operator interface terminal. It **should be** 24 volts DC.
- Check that the interface cable to both the PLC and the operator interface terminal are secure.

**NOTE:** Call the ADC Service Department at (508) 678-9000.

- 4b) Malfunctioning 24 volt DC power supply.

- Verify that the power supply’s red “ON” light is illuminated.
- Verify that 110 volt AC supply is available and correct.
- Verify that the 4-40 mA (4-40 milliampere) transmitters or operator interface terminal are not causing the power supply to fail.
- If the previous checked items are “OK,” replace the power supply.

- 5b) Malfunctioning hi-limit temperature controllers (HLS1 or HLS2).

- HLS1 - exhaust temperature hi-limit
- HLS2 - intake temperature hi-limit

HLS1 and HLS2 are monitored by a six (6) channel hi-limit temperature controller that once triggered **must be** manually reset.



## General Description:

The six (6) channels accept independent RTD (Resistive Temperature Device) inputs (spare channels have a 100 ohm [100 Ω] 5% tolerance resistors installed) and there is an individual set point for each channel. In operation, the scan rate between channels is four (4) to six (6) seconds, and the display will have the temperature measured by the individual RTD's. A "red" L.E.D. indicates an alarm condition; in the event of an alarm, scanning is halted and the "ALARM" relay de-energizes until the manual reset button is depressed.

**IMPORTANT:** If a hi-limit alarm occurs, check that a hi-temperature has not occurred. If no, correct the condition and test.

**IMPORTANT:** ***DO NOT*** TROUBLESHOOT THE SHLC (Sprinkler High Limit Controller) UNLESS THE WATER VALVE TO THE SPRINKLER IS CLOSED.

SHLC will cause:

- The sprinkler water valve to open.
- The entire dryer to power down.
- The "SPRINKLER RESET" button on the main panel to light.

- With the dryer control voltage "ON," not executing a drying cycle, one **should be** able to adjust the temperature settings on any of the hi-limit controllers and cause their respective "GREEN" L.E.D.'s (light emitting diodes) to cycle "ON" and "OFF."
  - If their corresponding L.E.D.'s (light emitting diodes) **do not** cycle, check their respective:
    - temperature sensors (RTD's [Resistive Temperature Device])
    - power connections
    - electrical circuits (refer to the ADS-464 main electrical wiring diagram)
    - If the previous items are "OK," replace the hi-limit controller.

## 6. "HI-TEMP FAULT" Message

PLC MESSAGE "HI-TEMP FAULT"

### a. *PROBABLE CAUSES;*

1. Airflow
2. Hi-limit temperature controllers (channel 1 and channel 2)
3. RTD 1 and 2
4. Fuse 10

### b. *POSSIBLE SOLUTIONS;*

1. For airflow problems refer to **D. External Supply Connections - 4. exhaust air ducting.**
2. An illuminated red indicator on the HI-LIMIT TEMP CONTROLLER indicates that the hi-limit control relay is in "ALARM" and in internal relay is "OPEN."

- If anyone of the HI-LIMIT temperature SENSORS sense an over temperature condition. It will open its control relay. (Refer to the ADS-464 ladder diagram for the effect of this relay.)
- If a “HI-TEMP FAULT” message is displayed, open the main electrical enclosure, and notice which channel has cycled. This will lead one in the direction of the fault.

HLS1 - MAXIMUM INTAKE TEMPERATURE

HLS2 - MAXIMUM EXHAUST TEMPERATURE

- The HI-Temp controller channel that has a GREEN LED “ON,” indicates the RTD that caused the message (HI-TEMP FAULT) to be displayed.
- Let the dryer cool and verify that GREEN LEDs resume scanning. Reset the controller by pressing the “REST” on the controller. This will verify that an over temperature condition occurred and the controller is operational.
- Go to 1 and check air flow.
- If hi-limit controller does not reset go to 3.

3. If either RTD (Resistive Temperature Device) 1 or 2 were to open or become disconnected, the associated temperature channel, of the hi-temp controller located on the main electrical panel, will sense the open and react by opening its respective control relay and never re-energize until the RTD is replaced. Once HI-LIMIT controller problem has been isolated to particular device, and a RTD temperature sensor is suspected:

Check the resistance of the RTD at its connector, located in the right hand cable through.

- If 0 ohms is measured:
  - Check RTD (Resistive Temperature Device)
  - Check wiring to the RTD (refer to ADS-464 Main Panel Wiring Diagram)
  - Check wiring to the HI-LIMIT temperature controller (refer to ADS-464 Main Panel Wiring Diagram.)
- If RTD measures in the range of 100 ohms (100Ω) :
  - Check wiring to the HI-LIMIT temperature controller (refer to ADS-464 Main Panel Wiring Diagram)
- If wiring checks out:
  - Replace the HI-LIMIT temperature controller
  - Re-Test

4. If there is no display on the hi-temperature controller.

- Check that main power is “ON;” front panel “**BLUE**” indicator
- Check that all emergency stop buttons are disengaged (out).

- Check fuse 10's blown fuse indicator
- Check wiring; refer to ADS-464 Main Panel Wiring Diagram
- Re-Test

## 7. "DRUM FAULT" Message

### PLC (PROGRAMMABLE LOGIC CONTROLLER) MESSAGE "DRUM FAULT"

#### a. *PROBABLE CAUSE*;

1. Stop motion detector module or sensor. With control voltage "ON" (green push-button), use the pendant control in "LOAD POSITION" to rotate the tumbler.

Note input #0, 10 on the PLC, stop the tumbler and wait for device's latched relay to de-energize. The time from when the tumbler stopped to the relay de-energizing should be 15-20 seconds.

- If the de-energizing time is satisfactory, the unit is operating correctly
  - Check circuit wiring, and Re-Test (refer to ADS-464 Main Panel Wiring Diagram)
- If the de-energizing time is incorrect:
  - Adjust the "time adjust" on the stop motion detector module and re-test

If the input # 0, 10 on the PLC is not on after several rotations of the tumbler:

- Check fuse 2 and replace if necessary.
- Rotate the tumbler using the pendant control in "LOAD POSITION." Does the module's L.E.D. respond?
  - If "YES," adjust the "sense time" until the L.E.D. (light emitting diode) stays on for 15-20 seconds after tumbler stops, then refer to **section 1 above**
  - If "NO," check:
    - Inductive proximity sensor for damage
    - Sensor distance from targets is 3/16". The proximity sensor is located in the same area as the tumbler junction box.
    - Inductive proximity adjustment
    - Tumbler target
    - Stop motion detector module
    - Circuit wiring; refer to ADS-464 main panel wiring diagram ADS-464 tumbler junction box wiring diagram

## B. TUMBLER SECTION ELECTRICAL MALFUNCTIONS

### INTRODUCTION

There are a number of electrical components associated with the ADS-464 tumbler section. These components are all interfaced to the tumbler junction box, and connected to the main electrical enclosure through a disconnectable cable.

The “tumbler junction box” is located on the left side of the tumbler, in the same area as the left drum motor. The title of the wiring for the tumbler section is “ADS-464 Tumbler Electrical Junction Box Wiring Diagram.” The tumbler section electrical components provide:

- Front and rear door position information
- Drum rotation information
- Rear panel controls for unloading
- EMERGENCY STOP (E-STOP)

The “tumbler junction box” is located on the left side of the tumbler section, in the same area as the left drum motor. The title of the wiring diagram for the tumbler section is “ADS-464 Tumbler Electrical Junction Box Wiring Diagram.” The tumbler section electrical components provide:

The following information will provide a means to respond to fault messages associated with the tumbler section, and verify all the electrical signals associated with it.

Refer to the ADS-464 Tumbler Junction Box Wiring Diagram for detailed wiring information.

#### 1.0 Tumbler Section Electrical Components

##### 1. Load Door Switch - DS1

The load door switch is located on the left side of the ADS-464 front doors and comprises of four (4) parts: head, arm, body and cord grip device. The head is a rotating type, with a spring arm attached for switch actuation. The body contains a double pole, double throw, normally open switch. DS1 has two (2) electrical functions, A and B.

##### 2. Unload Door Switch - DS2

The unload door switch is located on the right side of the ADS-464 rear doors and comprises of four (4) parts: Head, Arm, Body, Cord Grip device. The head is rotating type, with a spring arm attached for switch actuation. The body contains a double pole, double throw, switch. DS2 has two (2) electrical functions, A and B.

“A” provides rear door position signal to the PLC (Programmable Logic Controller).

“B” is a rear interlock to the burner controller circuit.

### 3. Drum Rotation Sensor - PRS1

The drum rotation sensor is an inductive pick up device located on the left wrapper of the tumbler section. Its function is to sense a metal “target” attached to the “basket” as it rotates. The mechanical adjustment of this device, (distance from the target) is crucial (3/16” from target).

**CAUTION: DO NOT MECHANICALLY ADJUST THE ROTATIONAL SENSOR SO FAR IN TO BE HIT BY THE ROTATING TARGET, PERMANENT DAMAGE OF THE SENSOR WILL OCCUR.**

### 4. Tumbler Junction Box

This enclosure interfaces the tumbler’s electrical hardware, to the ADS-464 Main Electrical Panel. The disconnect plug, attached to this enclosure, provides a means of electrical separation of these tumbler section, for shipping.

Refer to ADS-464 Tumbler Junction Box Diagram for detailed wiring information.

(The following is for 2-door dryers only)

### 5. Unload 1 “Rear Panel” - SEL 4

This is normally open, Two position, selector switch for unloading the ADS-464 from the rear. Once the selector switch is turned to “1,” Pendant control functions are disabled, rear doors open, and the dryer front tilts up.

### 6. DRUM FORWARD “Rear Panel” - PB3

This push button witch comprises of two individual switches; one normally open. One switch is for a drum forward signal to the PLC (Programmable Logic Controller) ; the other switch is for an electrical interlock to the DRUM REVERSE push button.

### 7. DRUM REVERSE “Rear Panel” - PB4

This push button switch comprises of two individual switches; one normally closed and one normally open. DRUM FORWARD push button.

### 8. EMERGENCY STOP (E-STOP) “Rear Panel” - PB7

This push button switch is normally closed device and is located on the right rear panel of the ADS-464 its function is to shutdown the control voltage to the dryer in the vent it is pressed.

**NOTE: It WILL NOT effect the Sprinkler Circuit Power.**

## 2 Rear Panel Control Problems

### EMERGENCY STOP (E-Stop) Function

#### a) *PROBABLE CAUSES:*

1. Rear panel disconnect plug
2. Defective switch
3. Wiring back to the main electrical enclosure

#### b) *POSSIBLE SOLUTIONS:*

1. If the EMERGENCY STOP (E-STOP) - rear - does not respond:
    - Verify that **ALL** other EMERGENCY STOP (E-STOP) buttons are pulled out
    - Verify that the rear panel's disconnect plug is indeed connected. The disconnect plug is to allow the removal of the panel for dryer servicing
  2. Defective EMERGENCY STOP (E-STOP) Switch
    - Shut power off (main breaker) remove the rear panel and check switch using an OHM meter; replace if defective
    - Re-test
  3. Wiring back to main electrical enclosure
    - Shut power off to the ADS-464 dryer (main breaker)
    - Open "disconnects" on terminal 16 and terminal 17 of TB1; These disconnects are located on the bottom of the main electrical enclosure.
    - Connect an OHM meter to the output side of terminal 16 and terminal 17 of TB1
    - Push in the Emergency Stop (E-Stop) button (opening the switch)
    - Does the previous test show that there is a switch closure opening?
      - If "YES," refer to **section 3a**
      - If "NO," refer to **section 3b**
- 3a) Wiring from the Emergency Stop button to the main electrical enclosure is okay.
- Check REAR PANEL CONTROLS WIRING DIAGRAM
  - Check TUMBLER JUNCTION BOX WIRING DIAGRAM
  - Refer to **section a above** and re-test

## Drum Forward and Reverse Function

### c) *PROBABLE CAUSES*;

2.1 Rear panel disconnect plug

2.2 Defective switches

2.3 Wiring back to the main electrical enclosure

### d) *POSSIBLE SOLUTIONS*;

1. If either the Drum forward or reverse functions (rear) do not respond.

- Verify that the rear panel controls disconnect plug is indeed connected. This disconnect plug allows for the removal of the rear control panel for dryer servicing.

2. Defective Forward and Reverse Switch

- Shut power off at the main breaker and remove the rear panel and check switches using an OHM meter; replace if defective
- Re-test

3. Wiring Back to Main Electrical Enclosure

- With the control voltage “ON” front panel green button
- Select “1” on the “O UNLOAD 1” switch located on the rear controls panel.
- Have someone PRESS either the forward or reverse buttons while you watch the input L.E.D.’s (light emitting diodes) of the programmable controller. Do the associated L.E.D.’s light?

PLC PIN 20 = DRUM FWD., REAR PANEL

PLC PIN 21 = DRUM REV., REAR PANEL

- If “YES,” refer to **section 2.2.3 A**
- If “NO,” refer to **section 2.2.3 B**

3b) The L.E.D.’s illuminating on the PLC (Programmable Logic Controller) indicate that the wiring to the PLC is correct.

- Check FUSE 2 on the main electrical panel
- Check wiring back to the tumbler junction box
- Check wiring back to the rear controls

- Refer to blueprints:
  - Main electrical panel diagram
  - Tumbler junction box wiring diagram
  - Rear panel controls wiring diagram
  - Re-test

#### 0 UNLOAD 1 Selection

##### e) *PROBABLE CAUSES;*

1. Rear panel disconnect plug
2. Defective switch
3. Wiring back to main electrical enclosure

##### f) *POSSIBLE SOLUTIONS;*

##### 1. If the O UNLOAD 1 switch doesn't respond when selected:

- Verify that the rear panel controls disconnect plug is indeed connected. This disconnect plug allows for the removal of the rear control panel for dryer servicing.

##### 2. Defective O UNLOAD 1 Selector Switch

- Shut power off at the main breaker and remove the rear panel and check switches using an OHM meter; replace if defective.

##### 3. Wiring back to the main electrical enclosure

- With the control voltage "ON" Front Panel "**GREEN**" Button
- Select "1" on the "O UNLOAD" switch located on the rear control panel. Does PLC (Programmable Logic Controller) IN PIN 19 = UNLOAD, REAR PANEL light?
  - If "YES," refer to **section 3a**
  - If "NO", refer to **section 3b**

##### 3a) The L.E.D. (light emitting diode) "ON" on the PLC (Programmable Logic Controller) indicates are also illuminating when the O UNLOAD 1 selector switch is on "1."

PLC OUT PIN 7 = UNLOAD DOOR (OPEN)

PLC OUT PIN 10 = FRONT UP

- If output indicators are functional, however the UNLOAD DOORS of FRONT UP commands are not executed correctly:



- Check wiring on the MAIN ENCLOSURE PANEL (Refer to the ADS-464 Main Panel Wiring Diagram)
  - Check wiring associated with Solenoid Junction Box.
  - See troubleshooting procedures associated with the Solenoid Junction Box.
- 3b) Input L.E.D. (light emitting diode) not illuminating correctly on the PLC (Programmable Logic Controller) indicates that the signal to the PLC input is missing or the PLC is defective.
- Check FUSE 2 on the main electrical panel
  - Check wiring back to the tumbler junction box
  - Check wiring back to the rear controls
  - Check PLC
    - Refer to blueprints
    - Main electrical panel diagram
    - Tumbler Junction box wiring PLC (Programmable Logic Controller) diagram
    - Rear panel controls wiring diagram
    - Re-test; verify that the signal is operational

### 3.0 “DOOR Open” Problem

A “DOOR OPEN” message is generated by either the heater, load, or unload doors. The following information will address the load and unload doors signals, since they are associated with the tumbler junction box.

#### a) *PROBABLE CAUSES;*

1. WIRING BACK THE PLC (Programmable Logic Controller)

DS1-B=LOAD DOOR SWITCH

DS2-B=UNLOAD DOOR SWITCH

#### b) *POSSIBLE SOLUTIONS;*

1. For quick check of LOAD and UNLOAD signals of the PLC perform the following:
  - Remove factory air from the dryer
  - With the Control Voltage “ON”, open the LOAD doors and locate the LOAD door switch actuator
  - Cycle the switch by hand and have someone watch PLC input indicator #6. It should go “ON” when the switch is down.

- Open the UNLOAD doors and locate the UNLOAD doors switch actuator.
- Cycle the switch by hand and have someone watch PLC (Programmable Logic Controller) input indicator #7. It should go “ON” when the switch is down. Do the associated L.E.D.’s (light emitting diode) come “ON” when switch is down?
  - If “YES,” wiring is OK
    - Check switch placement and door actuation
  - If “NO,” check associated:
    - Switch and wiring
    - Check wiring back to the tumbler junction box
    - Check wiring back to the rear controls
    - Check PLC (Programmable Logic Controller)
  - Refer to blueprints: Main Electrical Panel Diagram
    - Tumbler junction box diagram
    - Rare panel controls wiring diagram
  - Re-test; verify that the signal is operational

#### 4.0 “DRUM FAULT MESSAGE” Malfunction

##### a) *PROBABLE CAUSES*;

1. Stop Motion Detector module or sensor
2. Wiring back to main electrical enclosure

##### b) *PROBABLE SOLUTIONS*;

1. Open the Main Electrical Enclosure locate input #0, 10 on the PLC (Programmable Logic Controller). With control voltage “ON” (Green Push-Button), use the pendant to rotate the tumbler. Notice a L.E.D. (light emitting diode) on as the tumbler is rotating.

- If the L.E.D. is off, refer to **section 1a**

##### 1a) If the LED is off:

- Check Fuse 2; replace if necessary
- Rotate the tumbler using the pendant control, and adjust the stop
- Does the module’s L.E.D. respond?

- If yes, adjust the “Time Adjust” until the L.E.D. (light emitting diode) is on during rotation 15 to 20 seconds after the tumbler stops
  - If “NO,” check:
    - Inductive proximity sensor is located in the same area as the tumbler junction box
    - Inductive proximity mechanical adjustment
    - The target that is attached to the outside of the basket
    - Stop motion detector module
    - Circuit wiring; refer to ADS-464 Main Panel Wiring Diagram, ADS-464 Tumbler Junction Box Wiring Diagram
- 1b) If the L.E.D. (light emitting diode) is constantly “ON”
- If “YES,” the stop motion detector is defective
  - If “NO,” check:
    - Inductive proximity sensor for damage. The proximity sensor is located in the same area as the tumbler junction box.
    - Inductive proximity mechanical adjustment
    - Tumbler target...this target is attached to the outside of the basket
    - Stop motion detector module in the tumbler section on the left front side
    - Circuit Wiring; refer to ADS-464 Main Panel Wiring Diagram
    - ADS-464 Tumbler Junction Box Wiring Diagram

## C. BASE SECTION ELECTRICAL MALFUNCTIONS

### INTRODUCTION

There are four (4) electrical components associated with the ADS-464 base section. These components are interfaced to a junction box, and connect to the main electrical enclosure through a disconnect cable. The “Base Junction Box” is located on the right rear of the base section, and title of its wiring diagram is “ADS-464 Base Electrical Junction Box Wiring Diagram.” The base section of electrical components provide:

- Tumbler position information (Front Up - Level - Rear Up)
- Lint chamber pressure information
- Lint screen mechanism functioning okay information

The following information will provide a means to respond to “Base” associated Fault Messages, and to verify **ALL** the electrical signals associated with the Base Section. Refer to the ADS-464 Base Junction Box for a detailed wiring diagram.

#### 1.0 Base Section Electrical Components

##### 1. Front Door Switch

The “Front Down Sensing Switch” is located on the left side of the ADS-464 base and comprises of four parts; Head, Arm, Body, and Cord Grip device. The head is a rotating type, with a roller arm attached for switch actuation. The body contains a double pole, double throw, normally open switch. LS has two (2) electrical functions, A and B.

“A” provides a “rear down” signal to the PLC (Programmable Logic Controller)

“B” is used as an electrical interlock to the “rear up signal”

##### 2. Rear Down Switch - LS2

The “Rear Down Sensing Switch” is located on the left side of the ADS-464 base, and compromises of four (4) parts; Head, Arm, Body, and Cord Grip device. The head is a rotating type, with a roller arm attached for switch actuation. The body contains a double-pole-double-throw (DPDT), normally open switch.

“A” provides a “rear down” signal to the PLC (Programmable Logic Controller)

“B” is used as an electrical interlock to the “Front Up Signal”

##### 3. Lint Drawer Proximity Switches

The “Lint Drawer Proximity Switches” are located on the left side of the ADS-464 base, and is comprised of six (6) parts: Junction Box, 2 proximity switches, and 3 cord grip switches. The switches sense a magnet installed on the lint drawer that that verify that **ALL** safeties are met to the Burner Controller and also signal the PLC that enables the ADS-464 to begin drying cycle.

**NOTE:** Front and Rear Drawers are not interchangeable

“B” is used as an electrical interlock to the PLC’s 110 VAC output power

#### 4. Lint Chamber Pressure Switch -- PS3

The “Lint Chamber Pressure Sensing Switch” is located on the left rear side of the ADS-464 base. It is an adjustable pressure switch, which incorporate a single-pole-single-throw (SPST) switch. PS3’s electrical function is to close its switch when the present pressure in the lint chamber is sufficient. This switch is wired in series with other switches to form an interlock to the Burner Control Module.

### 2.0 Tumbler Tilt Problems “LEVEL FAULT”

A “LEVEL FAULT” message is generated by the incorrect state of either the FRONT or REAR sensor switches. The following information will address the “LEVEL” signals, since they are associated with the Base Electrical Junction Box.

#### a) *PROBABLE CAUSES;*

##### 1. WIRING BACK TO THE PLC (Programmable Logic Controller)

LS1-B=FRONT DOWN SWITCH

LS2-B=REAR DOWN SWITCH

#### b) *PROBABLE SOLUTIONS;*

##### 1. For a quick check of the FRONT DOWN and REAR DOWN signals to the PLC (Programmable Logic Controller) perform the following:

FRONT DOWN signal test procedure 1a

REAR DOWN signal test procedure 1b

##### 1a) Place the ADS-464 in the load position; Front Up

- Actuate the Front Down switch by hand
- Have someone verify that PLC (Programmable Logic Controller) input #11 lights when the switch actuator is down, and is OFF when the actuator is up.
- Does L.E.D. #11 come “ON” when the switch is down?
  - If “YES”, wiring is OK
- Check switch and actuator placement and tilt actuation.

**NOTE:** If actuator is at a 90° or greater angle with the base, actuator will damage if machine is lowered.

- If “NO,” check associated:
  - Switch and Wiring
  - Check wiring back to the base electrical junction box
  - Check PLC (Programmable Logic Controller)
  - Refer to blueprints: Main Electrical Panel Diagram, Base Electrical Junction Box Wiring Diagram
  - Re-test; verify that the signal is operational

1b) Place the ADS-464 in the UNLOAD position; TILTED FORWARD

- Actuate the Rear Down Switch by hand
- Have someone verify that PLC (Programmable Logic Controller) input L.E.D. #12 lights when the switch actuator is down, and is OFF when the actuator is up
- Does L.E.D. #12 come “ON” when the switch is down?
- If “YES,” wiring is OK
- Check switch, actuator placement and tilt actuation

**NOTE:** If actuator is at 90° or greater angle with the base, the actuator will be damaged if machine is lowered.

- If “NO,” check associated:
  - Switch and wiring
  - Check wiring back to the base electrical junction box
  - Check PLC (Programmable Logic Controller)
  - Refer to blueprints: Main Electrical Panel Diagram, Base Electrical Junction Box Wiring Diagram
  - Re-test; verify that the signal is operational

### 3.0 Lint Screen Mechanism Problem “SCREEN FAULT”

A “SCREEN FAULT” message is generated by the incorrect state of the lint screen mechanism sensor switch. The following information will address the correct signal, since it is associated with the Base Electrical Junction Box.

a) *PROBABLE CAUSES*

1. THE LINT SCREEN **MUST BE** CLEANED EVERY FIVE (5) DRYING CYCLES

2. WIRING BACK TO THE PLC (Programmable Logic Controller), 0, 8

a) *PROBABLE CAUSES;*

1. CLOGGED LINT SCREEN OR LINT BAG
2. AIR PRESSURE SETTING
3. AIR PRESSURE SWITCH - PS3 OR WIRING BACK TO THE PLC (Programmable Logic Controller)

b) *POSSIBLE SOLUTIONS;*

1. Perform preventive maintenance and screen cleaning procedures.
2. Set correct pressure settings.
3. For a quick check of the AIR PRESSURE SWITCH WIRING, perform the following:
  - Run a drying cycle
  - Does the pressure switch's indicator come "ON"?
    - If "YES," switch and its adjustment
    - If "NO," check switch and its adjustment
  - Verify that PLC (Programmable Logic Controller) input L.E.D. #5 comes "ON"
  - Does L.E.D. #5 come "ON" when the switch is active?
    - If "YES," wiring is OK
    - If "NO," check:
      - Switch, its setting and wiring
      - Check wiring back to the base electrical junction box
      - Check PLC (Programmable Logic Controller)
      - Refer to blueprints: Main Electrical Panel Diagram, Base Junction Box Wiring Diagram
  - Re-test; verify that the signal is operational

## D. PENDANT CONTROL MALFUNCTIONS

### INTRODUCTION

There are four (4) electrical switches associated with the ADS-464 Pendant assembly. These components are interfaced to TB1 of Main Electrical Enclosure through two (2) disconnects and two (2) junction boxes.

The Pendant Assembly is remote control for Loading or Unloading the ADS-464. The functions provided are:

- LOAD - LEVEL - UNLOAD
- TUMBLER REVERSE
- TUMBLER FORWARD
- EMERGENCY STOP (E-STOP)

The following information will provide a means to respond to “Pendant” malfunction, and to verify **ALL** its electrical signals. Refer to the following ADS-464 Pendant associated wiring diagrams for detailed assembly and wiring information.

- ADS-464 PENDANT ASSEMBLY DIAGRAM
- ADS-464 ANNUNCIATOR, PENDANT, AND UPPER RTD’S WIRING DIAGRAM

#### 1.0 Pendant Electrical Components

- Load - Level - Unload ----- A and B
- Tumbler Reverse Switch ----- PB2
- Tumbler Forward Switch ----- PB1
- Emergency Stop (E-Stop) Switch - PB6

There are two (2) normally open electrical switches associated with this switch function, that are actuated by three (3) position selector.

SEL A = LOAD

SEL B = UNLOAD

Once this switch is turned to “LOAD”, the dryer’s front doors will open, and depending upon system configuration, will either tilt back or remain level.

- If the ADS-464 was configured to Unload from the front: Any time this switch is turned to “UNLOAD”, the dryers front doors will open, and its tumbler will tilt to the front.
- If the ADS-464 was configured to Unload from the rear: Anytime this switch is turned to “UNLOAD”, nothing will happen. **ALL** unloading functions will be transferred to the rear control panel.
- TUMBLER REVERSE “PENDANT” --- PB2

This push button comprises of one (1) normally open switch, and is mechanically interlock with the Tumbler Forward Push-Button.



- TUMBLER FORWARD “PENDANT” --- PB1

This push button comprises of one normally open switch, and is mechanically interlock with Tumbler Reverse Push Button.

- EMERGENCY STOP (E-STOP) “PENDANT” --- PB6

This push button switch is normally open device and its function is to shut down the control voltage to the dryer in the event it is pressed.

**NOTE:** It **WILL NOT** effect the sprinkler circuit power.

## 2.0 Verify Pendant Electrical Signals

**ALL** the pendant control signals are interfaced to the Main Electrical Panel’s PLC (Programmable Logic Controller) except for “Emergency Stop.”

- Load - Level - Unload Switch ----- A and B
- Tumbler Reverse Switch ----- PB2
- Tumbler Forward Switch ----- PB1
- Emergency Stop (E-Stop) Switch - PB6

For a quick check of the wiring of SEL 1 and 2 to the PLC (Programmable Logic Controller) perform the following test with the control voltage “ON”. (Green Button)

- Turn the selector switch to LOAD
  - Does PLC (Programmable Logic Controller) input L.E.D. #15 light?
- Turn the selector switch to UNLOAD
  - Does PLC (Programmable Logic Controller) input #16 light?
- Turn the selector switch to LEVEL
  - Are both PLC (Programmable Logic Controller) input #15 and input #16 “OFF”?
  - If the answers to these questions are “YES,” wiring to the PLC (Programmable Logic Controller) is correct
  - If any answer to these questions is “NO,” refer to **Probable Causes paragraph on page 74 and page 75**
- Tumbler Reverse Switch --- PB2
  - For a quick check of the wiring of PB2 to the PLC perform the following test with control voltage “ON” (“**GREEN**” button)
  - Press the REVERSE Push-button.
    - Does PLC (Programmable Logic Controller) input L.E.D. #18 light?

- Release the REVERSE Push-button
  - Does PLC (Programmable Logic Controller) input L.E.D. #18 go “OFF”?
  - If the answers to these questions are “YES,” wiring to the PLC is correct.
  - If any answer to these questions is “NO,” refer to **Probable Causes below**
- Tumbler Forward Switch --- PB1

For quick check of the wiring of PB1 to the PLC (Programmable Logic Controller) perform the following test with the control voltage “ON” (“**GREEN**” button).

- Press the FORWARD Push-button.
  - Does PLC (Programmable Logic Controller) input L.E.D. #17 light?
- Release the REVERSE Push-button.
  - Does PLC (Programmable Logic Controller) input L.E.D. #17 go “OFF”?
  - If the answer to these questions are “YES,” wiring to the PLC (Programmable Logic Controller) is correct.
  - If the answer to these questions are “NO,” refer to **Probable Causes below**

a) *PROBABLE CAUSES;*

1. FUSE 4 ON MAIN ELECTRICAL PANEL
2. FAULTY SWITCHES
3. WIRING BACK TO PLC (Programmable Logic Controller)

b) *POSSIBLE SOLUTIONS;*

1. Check fuse blown indicator on fuse 4; replace fuse, if necessary and re-test.
  2. Check switches using an OHM meter; replace if necessary, and re-test.
  3. Refer to ADS-464 Pendant associated wiring diagrams for detailed assembly and wiring information. Check **ALL** circuits back to PLC (Programmable Logic Controller).
    - ADS-464 PENDANT ASSEMBLY DIAGRAM
    - ADS-464 ANNUNCIATOR, PENDANT, and UPPER RTD’S (Resistive Temperature Device) WIRING DIAGRAM
- EMERGENCY STOP (E-Stop) SWITCH --- PB6

If the “Emergency Stop” switch (pendant) does not respond:

- EMERGENCY STOP (E-STOP) SWITCH --- PB6

If the “Emergency Stop” switch (pendant) does not respond:

c) *PROBABLE CAUSES*;

1. ANOTHER EMERGENCY STOP (E-STOP) BUTTON
2. A DISCONNECT PLUG
3. FAULTY SWITCH
4. WIRING BACK TO TB1

d) *POSSIBLE SOLUTIONS*;

1. Verify that **ALL** other “Emergency Stop” (E-Stop) buttons are not pushed in, and re-test.
2. Verify that **ALL** of the Pendant’s disconnect plugs are indeed connected. The disconnect plugs are for removal of the Pendant arm for shipping.
3. With the control voltage off, open pendant assembly and check switch using an OHM meter, replace if defective.
4. Locate terminals 14 and 15 on TB1 on the bottom of the electrical enclosure. Open their associated disconnects and place an OHM meter across these terminals. Push the Emergency Stop (E-Stop) button in. Does the OHM meter respond?
  - If “YES,” wiring from the pendant to TB1 is correct, check wiring on the main electrical panel, then re-test.
  - If “NO,” wiring from the TB1 is incorrect. Check wiring using the appropriated wiring diagrams listed above, and re-test.

## E. TEMPERATURE SENSING

### INTRODUCTION

There is one (1) temperature sensing and controlling device in the ADS-464 located in the intake exhaust. The temperature sensing devices are RTD’s (Resistance Temperature Devices), whose resistance changes with temperature information from each RTD is forwarded to a respective 4 to 20 milliampere (4 to 20 mA) transmitter located on the Main Electrical Enclosure Panel. The converted signal is then connected to the PLC’s analog input module for further processing.

The following information will provide a means to respond to “Temperature Sensing” malfunctions, and verify all its electrical signals. Refer to the following diagrams placement and wiring information.

- ADS-464 ANNUNCIATOR, PENDANT, and UPPER RTD’S WIRING DIAGRAM
- ADS-464 MAIN PANEL WIRING DIAGRAM
- ADS-464 SYSTEM BLOCK DIAGRAM

## 1. TEMPERATURE SENSING COMPONENT DESCRIPTIONS

- Exhaust RTD (Resistance Temperature Device)- Sens1

The RTD (Resistance Temperature Device), used throughout the ADS-464 are identical. The main function is to measure temperatures and to transfer this information to a measuring devices for further processing. The RTD used on the ADS-464 are rated for 1100° F (593.3° C).

- Sens2 = Exhaust Temperature Sensor

The exhaust RTD (Resistance Temperature Device) is located in the ADS-464 burner area exhaust duct and also has electrical disconnects in a junction box for ease of replacement.

- Exhaust 4 to 20 milliampere (4 to 20 mA) transmitter - Trans1

This transmitter is located on the upper right of the main electrical enclosure panel. The intake and exhaust RTD (Resistance Temperature Device) are respectively connected in series with a 24 volt DC power supply, and the current drawn from the power supply is 4 to 20 milliampere (4 to 20 mA) output signal which is proportional to the input signal. The proportional current information is the connected to the PLC (Programmable Logic Controller) for processing. Refer to the ADS-464 Ladder Diagram for circuit information.

- 24 Volt DC Power Supply

The 24 volt power supply used in the ADS-464 is an individual grade switching power supply, rated for 120 volts AC input and 24 volts DC output. Features this device incorporates are:

- Overload protection to protect the load
- Internal failure protection to protect itself
- An output status indicator; this L.E.D. (light emitting diode) indicates the presence of DC output voltage.
- PLC (Programmable Logic Controller) Analog Input Module - Module #2

This device, attached to the PLC , receives the 4 to 20 milliampere (4 to 20 mA) temperature information and processes this information for the PLC

- Temperature Measurement and Sensing Problems

An “EXHAUST DSFL” MESSAGE is displayed on the operator terminal any time a respective temperature measurement has exceeded the programmed temperature in the PLC (Programmable Logic Controller). A “DSFL” message will stop the current drying cycle and prevent a drying cycle from starting.

## 2. EXHAUST “DSFL” MESSAGE

- a) *PROBABLE CAUSES*;

1a) Defective RTD (Resistive Temperature Device) Probe

2a) Defective 24 Volt DC Power Supply

3a) Defective Analog Input Module For Channel

4a) RTD (Resistive Temperature Device) Wiring To The “EXHAUST” 4 to 20 milliamphere (4 to 20 mA) Transmitter

5a) Circuit Wiring To the Analog Input Module

b) *POSSIBLE SOLUTIONS;*

1b) With the control voltage “OFF.”

The exhaust RTD (Resistive Temperature Device) probe can be quickly checked, by locating its labeled disconnect in the right hand wire which is located on the main electrical enclosure panel. Disconnect this plug and measure the resistance of the two wires coming from the RTD; it **should be** in the 100 ohm (100  $\Omega$ ) range.

- If resistance is within range, wiring and RTD are OK.
- If the resistance is infinite (no measurements), or zero ohms (0  $\Omega$ ), go directly to the intake RTD (Resistive Temperature Device) disconnect box and measure the RTD’s resistance directly.
- If the RTD resistance measurements is acceptable, check circuit wiring.
- If the RTD resistance measurements is not acceptable; replace RTD and re-test

2b) Defective 24 Volt DC Power Supply

With the control voltage “ON,” check that 100 volts AC is applied to the device’s AC input.

- If no voltage check fuse #8, and wiring and re-test.

Check that the device’s DC output indicator is “ON.”

- If “OFF”, this indicates that there is no 24 volts DC output

Disconnect the output voltage wires connected to the power supply and notice if the L.E.D. (light emitting diode) indicator responds

- If the power supply responds to the disconnection, there is a problem with the driven load and not the power supply itself

- Check **ALL** loads and re-test

Check that the device’s output voltage is 24 volts DC.

- If not, adjust it

### 3. DEFECTIVE ANALOG INPUT MODULE or CHANNEL

Replace Analog Input Module

#### 4. RTD (Resistive Temperature Device) WIRING TO THE “EXHAUST” 4 to 20 MILLIAMPERE (4 to 20 mA) TRANSMITTER

Check **ALL** wiring and ADS-464 connection from the exhaust RTD (Resistive Temperature Device) probe to the exhaust 4 to 20 milliamper (4 to 20 mA) transmitter. Refer to the ADS-464 EXHAUST Temperature Assembly and Wiring Diagram, ADS-464 Main Panel Wiring Diagram.

#### 5. CIRCUIT WIRING TO THE ANALOG INPUT MODULE

Check **ALL** wiring and connections from the 4 to 20 milliamper (4 to 20 mA) transmitter to the PLC (Programmable Logic Controller) Analog Input Module. Refer to the ADS-464 Main Panel Wiring Diagram.

## F. MOTORS

### INTRODUCTION

The four (4) motors installed on the ADS-464 are connected directly to associated thermal magnetic starters in the main electrical enclosure. The troubleshooting information included in this section will cover the actuation, power control and safety devices to these motors.

The ADS-464 motors include:

- MAIN BLOWER FAN MOTOR
- BURNER FAN MOTOR
- LEFT (Basket) TUMBLER MOTOR
- RIGHT (Basket) TUMBLER MOTOR

Refer to the following diagrams for functional, and wiring information:

- ADS-464 MAIN PANEL WIRING DIAGRAM
- ADS-464 SYSTEM BLOCK DIAGRAM
- Motor Actuating Device Information

**ALL** ADS-464 motor contactors have 110 volts 50/60 Hz actuation coils. Three (3) motor contactors are actuated by outputs from the PLC (Programmable Logic Controller), and one contactor is actuated by the Burner Controller Module (BCM).

- Motor Protection Device Descriptions

The motor protection devices in the ADS-464 incorporate a manual disconnect switch, thermal overload relay, and instantaneous trip mechanism in one compact device. A two (2) position, normally open, auxiliary contact block has been attached to **ALL** motor protection devices to provide the “MOTOR FAULT” display message, and shut down “**ALL**” motors in the event a motor should trip.

#### 1. Motor Actuation Problems

##### a) *PROBABLE CAUSES;*

1a) Motor Protection Device “OFF” or “TRIPPED.”

2a) PLC (Programmable Logic Controller) Output Signal Defective

3a) Motor Circuit Wiring

b) *PROBABLE SOLUTIONS*;

1b) Verify that all motor protection devices (manual starters) have their “START” buttons pushed in. If any device has tripped, reset it and restart the dryer. If the same devices continue to trip:

- Verify current setting
- Check circuit
- Check motor
- Re-test

2b) Verify that the associated output L.E.D. (light emitting diode) on the PLC (Programmable Logic Controller) is active. Verify that the associated output signal protection fuse is good. Check associated PLC output circuit wiring to associated motor starter coil (“A” terminals).

3b) Re-test

4b) Check associated motor starter circuit wiring to and from motor starters, and to the associated motors themselves. Refer to the ADS-464 Main Panel Wiring Diagram; re-test.

## G. PLC (Programmable Logic Controller) ERROR MESSAGES

The ADS-464 diagnostics messages have been provided to aid troubleshooters in diagnosing and repairing dryer problems. The messages are intended to direct one to a particular fault area for further testing; not to diagnose the machine for you.

**NOTE:** Not ALL ADS-464 dryer symptoms have fault messages.

The following information describes the action the ADS-464 will take while displaying a particular message.

<b>ERROR MESSAGES</b>	<b>ADS-464 IDLING</b>	<b>ADS-464 RUNNING</b>
CTRL VOLT OFF	Cannot operate machine	Stops dryer
INTAKE	Cannot operate machine	Stops dryer
EXHAUST DSFL	Cannot operate machine	Stops dryer
DOOR OPEN	Cannot operate machine	Stops dryer
SCREEN FAULT	Cannot operate machine	Stops dryer
MOTOR FAULT	Cannot operate machine	Stops dryer
GAS FAULT	Not Applicable	Burner Controller stops heat
AIR FAULT	Not Applicable	Burner Controller stops heat
HEATER FAULT	Not Applicable	Burner Controller stops heat
HI-TEMP FAULT	Not Applicable	Burner Controller stops heat
DRUM FAULT	Not Applicable	Burner Controller stops heat
LEVEL FAULT	Cannot operate machine	Stops dryer
LINE FAULTS*	Cannot operate machine	Cannot operate machine

\* This message is generated by the operator terminal itself; it indicates that communication between the operator terminal and PLC (Programmable Logic Controller) have discontinued.



ADC 112103    1- 06/18/96-3    2- 06/24/96-25    3\* 11/12/99-20

