

# AD-115

## Installation/Operator's Manual

**WARNING:** For your safety the information in this manual must be followed to minimize the risk of fire or explosion or to prevent property damage, personal injury or death.

—Do not store or use gasoline or other flammable vapor and liquids in the vicinity of this or any other appliance.

—WHAT DO YOU DO IF YOU SMELL GAS

- \* Do not try to light any appliance.
- \* Do not touch any electrical switch; do not use any phone in your building.
- \* Clear the room, building or area of all occupants.
- \* Immediately call your gas supplier from a neighbor's phone. Follow the gas supplier's instructions.
- \* If you cannot reach your gas supplier, call the fire department.

—Installation and service must be performed by a qualified installer, service agency or the gas supplier.

**AVERTISSEMENT:** Assurez-vous de bien suivre les instructions données dans cette notice pour réduire au minimum le risque d'incendie ou d'explosion ou pour éviter tout dommage matériel, toute blessure ou la mort.

—Ne pas entreposer ni utiliser d'essence ni d'autres vapeurs ou liquides inflammables dans le voisinage de cet appareil ou de tout autre appareil.

—QUE FAIRE SI VOUS SENTEZ UNE ODEUR DE GAZ:

- \* Ne pas tenter d'allumer d'appareil.
- \* Ne touchez à aucun interrupteur. Ne pas vous servir des téléphones se trouvant dans le bâtiment où vous vous trouvez..
- \* Évacuez la pièce, le bâtiment ou la zone.
- \* Appelez immédiatement votre fournisseur de gaz depuis un voisin. Suivez les instructions du fournisseur.
- \* Si vous ne pouvez rejoindre le fournisseur de gaz, appelez le service des incendies.

—L'installation et l'entretien doivent être assurés par un installateur ou un service d'entretien qualifié ou par le fournisseur de gaz.



For replacement parts, contact the distributor from which the dryer was purchased or

**American Dryer Corporation**

88 Currant Road

Fall River MA 02720-4781

Telephone: (508) 678-9000 / Fax: (508) 678-9447

e-mail: techsupport@amdry.com

## Retain This Manual In A Safe Place For Future Reference

**American Dryer Corporation** products embody advanced concepts in engineering, design, and safety. If this product is properly maintained, it will provide many years of safe, efficient, and trouble-free operation.

*ONLY qualified technicians should service this equipment.*

**OBSERVE ALL SAFETY PRECAUTIONS** displayed on the equipment or specified in the installation/operator's manual included with the dryer.

The following “**FOR YOUR SAFETY**” caution **must be** posted near the dryer in a prominent location.

### FOR YOUR SAFETY

Do not store or use gasoline or other flammable vapors or liquids in the vicinity of this or any other appliance.

### POUR VOTRE SÉCURITÉ

Ne pas entreposer ni utiliser d'essence ni d'autres vapeurs ou liquides inflammables dans le voisinage de cet appareil ou de tout autre appareil.

We have tried to make this manual as complete as possible and hope you will find it useful. **ADC** reserves the right to make changes from time to time, without notice or obligation, in prices, specifications, colors, and material, and to change or discontinue models.

## Important

For your convenience, log the following information:

DATE OF PURCHASE \_\_\_\_\_ MODEL NO. **AD-115** \_\_\_\_\_

DISTRIBUTORS NAME \_\_\_\_\_

Serial Number(s) \_\_\_\_\_

\_\_\_\_\_

\_\_\_\_\_

Replacement parts can be obtained from your distributor or the **ADC** factory. When ordering replacement parts from the factory, you can FAX your order to **ADC** at (508) 678-9447 or telephone your orders directly to the **ADC** Parts Department at (508) 678-9000. Please specify the dryer **model number** and **serial number** in addition to the **description** and **part number**, so that your order is processed accurately and promptly.

### **“IMPORTANT NOTE TO PURCHASER”**

Information must be obtained from your local gas supplier on the instructions to be followed if the user smells gas. These instructions must be posted in a prominent location near the dryer.

## **IMPORTANT**

**YOU MUST DISCONNECT and LOCKOUT THE ELECTRIC SUPPLY and THE GAS SUPPLY or THE STEAM SUPPLY BEFORE ANY COVERS or GUARDS ARE REMOVED FROM THE MACHINE TO ALLOW ACCESS FOR CLEANING, ADJUSTING, INSTALLATION, or TESTING OF ANY EQUIPMENT per OSHA (Occupational Safety and Health Administration) STANDARDS.**

“Caution: Label all wires prior to disconnection when servicing controls. Wiring errors can cause improper operation.”

«Attention: Lors des opérations d’entretien des commandes étiqueter tous fils avant de les déconnecter. Toute erreur de câblage peut être une source de danger et de panne.»

## **CAUTION**

**DRYERS SHOULD NEVER BE LEFT UNATTENDED WHILE IN OPERATION.**

## **WARNING**

**CHILDREN SHOULD NOT BE ALLOWED TO PLAY ON OR NEAR THE DRYER(S).  
CHILDREN SHOULD BE SUPERVISED IF NEAR DRYERS IN OPERATION.**

## **FOR YOUR SAFETY**

**DO NOT DRY MOP HEADS IN THE DRYER.  
DO NOT USE DRYER IN THE PRESENCE OF DRY CLEANING FUMES.**

## **WARNING**

**UNDER NO CIRCUMSTANCES should the door switch or the heat circuit devices ever be disabled.**

**WARNING**

The dryer must never be operated with any of the back guards, outer tops, or service panels removed. **PERSONAL INJURY or FIRE COULD RESULT.**

**WARNING**

**DRYER MUST NEVER BE OPERATED WITHOUT THE LINT FILTER/SCREEN IN PLACE, EVEN IF AN EXTERNAL LINT COLLECTION SYSTEM IS USED.**

**IMPORTANT**

**PLEASE OBSERVE ALL SAFETY PRECAUTIONS displayed on the equipment and/or specified in the installation and operator's manual included with the dryer.**

Dryers **must not** be installed or stored in an area where it will be exposed to water or weather.

The wiring diagram for the dryer is located in the front electrical control box area.

$$\begin{array}{r} \square\square\square 2 \overline{) 21 \square 500 \square} \quad \underbrace{\quad \quad}_{500} \frac{1}{100} \square \frac{5}{100} \frac{1}{10} \end{array}$$

**SECTION I**

**IMPORTANT INFORMATION..... 3**

    A. Receiving and Handling ..... 3

    B. Safety Precautions ..... 4

**SECTION II**

**SPECIFICATIONS AND COMPONENT IDENTIFICATION ..... 6**

    A. Specifications (Gas and Steam) ..... 6

    B. Component Identification ..... 8

**SECTION III**

**INSTALLATION PROCEDURES ..... 10**

    A. Location Requirements ..... 10

    B. Unpacking and Setting Up ..... 11

    C. Dryer Enclosure Requirements ..... 13

    D. Fresh Air Supply Requirements ..... 14

    E. Exhaust Requirements ..... 15

    F. Electrical Information ..... 22

    G. Gas Information ..... 29

    H. Steam Information ..... 33

    I. Preparation For Operation/Start-Up ..... 37

    J. Preoperational Tests ..... 38

**SECTION IV**

**SERVICE AND PARTS INFORMATION ..... 41**

    A. Service ..... 41

    B. Parts ..... 41

**SECTION V**  
**WARRANTY INFORMATION ..... 42**  
    A. Returning Warranty Cards ..... 42  
    B. Parts ..... 42

**SECTION VI**  
**ROUTINE MAINTENANCE ..... 44**  
    A. Cleaning ..... 44  
    B. Adjustments ..... 46  
    C. Lubrication ..... 46

**SECTION VII**  
**DATA LABEL LOCATION AND INFORMATION ..... 47**

**SECTION VIII**  
**PROCEDURE FOR FUNCTIONAL CHECK OF REPLACEMENT**  
**COMPONENTS ..... 53**

# SECTION I

## IMPORTANT INFORMATION

### A. RECEIVING and HANDLING

The dryer is shipped in a protective stretch wrap cover with protective cardboard corners and top cover (or optional box) as a means of preventing damage in transit. Upon delivery, the dryer and/or packaging, and wooden skid **should be** visually inspected for shipping damage. If any damage whatsoever is noticed, inspect further before delivering carrier leaves.

Dryers damaged in shipment:

1. **ALL** dryers **should be** inspected upon receipt and before they are signed for.
2. If there is suspected damage or actual damage, the trucker's receipt **should be** so noted.
3. If the dryer is damaged beyond repair, it **should be** refused. Those dryers which were not damaged in a damaged shipment **should be** accepted, but the number received and the number refused **must be** noted on the receipt.
4. If you determine that the dryer was damaged after the trucker has left your location, you should call the delivering carrier's freight terminal immediately and file a claim. The freight company considers this concealed damage. This type of freight claim is very difficult to get paid and becomes extremely difficult when more than a day or two passes after the freight was delivered. It is your responsibility to file freight claims. Dryer/parts damaged in transit **cannot** be claimed under warranty.
5. Freight claims are the responsibility of the consignee, and **ALL** claims **must be** filed at the receiving end. **ADC** assumes no responsibility for freight claims or damages.
6. If you need assistance in handling the situation, please contact the **ADC** Traffic Manager at (508) 678-9000.

<b>IMPORTANT:</b> The dryer <i>must be</i> transported and handled in an upright position at all times.
---

## B. SAFETY PRECAUTIONS

**WARNING:** For your safety, the information in this manual *must be* followed to minimize the risk of fire or explosion or to prevent property damage, personal injury, or loss of life.

**WARNING:** The dryer must never be operated with any of the back guards, outer tops, or service panels removed. **PERSONAL INJURY or FIRE COULD RESULT.**

1. **DO NOT** store or use gasoline or other flammable vapors and liquids in the vicinity of this or any other appliance.
2. Purchaser and user should consult the local gas supplier for proper instructions to be followed in the event the user smells gas. The instructions **should be** posted in a prominent location.
3. WHAT TO DO IF YOU SMELL GAS...
  - a. **DO NOT** try to light any appliance.
  - b. **DO NOT** touch any electrical switch.
  - c. **DO NOT** use any phone in your building.
  - d. Clear the room, building, or area of **ALL** occupants.
  - e. Immediately call your gas supplier from a neighbor's phone. Follow the gas supplier's instructions.
  - f. If you **cannot** reach your gas supplier, call the fire department.
4. Installation and service **must be** performed by a qualified installer, service agency, or gas supplier.
5. Dryers **must be** exhausted to the outdoors.
6. Although **ADC** produces a very versatile machine, there are some articles that, due to fabric composition or cleaning method, **should not** be dried in it.

**WARNING:** Dry only water-washed fabrics. **DO NOT** dry articles spotted or washed in dry cleaning solvents, a combustible detergent, or "all purpose" cleaner. **EXPLOSION COULD RESULT.**

**WARNING:** **DO NOT** dry rags or articles coated or contaminated with gasoline, kerosene, oil, paint, and wax. **EXPLOSION COULD RESULT.**

**WARNING:** **DO NOT** dry mop heads. Contamination by wax or flammable solvents will create a fire hazard.



**WARNING:** *DO NOT* use heat for drying articles that contain plastic, foam, sponge rubber, or similarly textured rubber materials. Drying in a heated basket (tumbler) may damage plastics or rubber and also may be a fire hazard.

7. A program **should be** established for the inspection and cleaning of lint in the heating unit area, exhaust duct work, and inside the dryer. The frequency of inspection and cleaning can best be determined from experience at each location.

**WARNING: THE COLLECTION OF LINT IN THE BURNER AREA and EXHAUST DUCT WORK CAN CREATE A POTENTIAL FIRE HAZARD.**

8. For personal safety, the dryer **must be** electrically grounded in accordance with local codes and/or the National Electric Code ANSI/NFPA NO. 70-LATEST EDITION or in Canada, the CANADIAN ELECTRICAL CODES PARTS 1 & 2 CSA C22.1-1990 or LATEST EDITION.

**NOTE:** Failure to do so will VOID THE WARRANTY.

9. **UNDER NO CIRCUMSTANCES** should the dryer door switches, lint door switch, heat safety circuit ever be disabled.

**WARNING: PERSONAL INJURY or FIRE COULD RESULT.**

10. This dryer is not to be used in the presence of dry cleaning solvents or fumes.

11. Remove articles from the dryer as soon as the drying cycle has been completed.

**WARNING:** Articles left in the dryer after the drying and cooling cycles have been completed can create a fire hazard.

12. **DO NOT** operate steam dryers with more than 125 PSI steam pressure. Excessive steam pressure can damage steam coil or harm personnel.

13. Replace leaking flexible hoses or other steam fixtures immediately. **DO NOT** operate the dryer with leaking flexible hoses. **PERSONAL INJURY MAY RESULT.**

14. **READ and FOLLOW ALL CAUTION and DIRECTION LABELS ATTACHED TO THE DRYER.**

**WARNING: YOU MUST DISCONNECT and LOCKOUT THE ELECTRIC SUPPLY and THE GAS SUPPLY BEFORE ANY COVERS or GUARDS ARE REMOVED FROM THE MACHINE TO ALLOW ACCESS FOR CLEANING, ADJUSTING, INSTALLATION, or TESTING OF ANY EQUIPMENT per OSHA (Occupational Safety and Health Administration) STANDARDS.**

# SECTION II

## SPECIFICATIONS/COMPONENT IDENTIFICATION

### A. SPECIFICATIONS

Maximum Capacity (Dry Weight)		115 lbs.	<b>52.2 kg</b>		
Basket Diameter		42"	<b>106.7 cm</b>		
Basket Depth		42"	<b>106.7 cm</b>		
Basket Motor		3/4 HP	<b>.560 kw</b>		
Blower Motor		3 HP	<b>2.238 kw</b>		
Door Opening (Diameter)		31-3/8"	<b>79.7 cm</b>		
Basket Volume		33.7 cu. ft.	<b>.98 cu. m.</b>		
Dryers Per 20' / 40' Container		4/8			
Dryers Per 45' / 48' Truck		9/10			
<b>Gas</b>	Voltage Available*		208-460v 3ø 3,4w 50/60 Hz		
	Heat Input		343,000 Btu/hr <b>86,436 kcal/hr</b>		
	Approx. Weight (Uncrated)		1,300 lb <b>591 kg</b>		
	Approx. Weight (Crated)		1,500lb <b>682 kg</b>		
	Airflow		2,100 cfm <b>59.4 cmm</b>		
	Inlet Size		1" <b>2.54 cm</b>		
<b>Electric</b>	Voltage Available**		208-460v 3ø 3,4w 50/60 Hz		
	Oven Size				
		kw	Btu/hr	kcal/hr	Airflow
		<b>60</b>	205,000	<b>51,620</b>	1,700 cfm <b>48.5 cmm</b>
		<b>72</b>	246,000	<b>61,944</b>	2,100 cfm <b>59.5 cmm</b>
	<b>80</b>	273,300	<b>68,827</b>	2,420 cfm <b>68.5 cmm</b>	
<b>Steam</b>	Voltage Available*		208-460v 3ø 3,4w 50/60 Hz		
	Approx. Weight (Uncrated)		1650 lbs.	<b>748.4 kg</b>	
	Approx. Weight (Crated)		1,875 lbs.	<b>850.5 kg</b>	
	Heat Input		12 Bhp		
	Steam Consumption		410 lbs/hr	<b>186.3 kg/hr</b>	
	Airflow		2,700 cfm	<b>76.46 cmm</b>	
	Inlet Size		1-1/4"	<b>3.18 cm</b>	
	80 PSI Compressed Air		1/8" F.P.T.	<b>.318 cm</b>	

*Shaded area are stated in metric equivalents*

\* Refer to the **Electrical Service Specification** chart on **page 23** for detailed electrical information.

\*\* Refer to the **Electrical Service Specification** chart on **page 24** (60 Kw oven), **page 25** (72 Kw oven), and **page 26** (80 Kw oven) for detailed electrical information.

**IMPORTANT:** Steam dryers *must be* provided with a clean, dry, regulated 80 PSI (+/-10 PSI) air supply.

**NOTE:** ADC reserves the right to make changes in specifications at any time, without notice or obligation.

# Specifications

## ADG-115 (Gas)

## ADE-115 (Electric)

## ADS-115 (Steam)

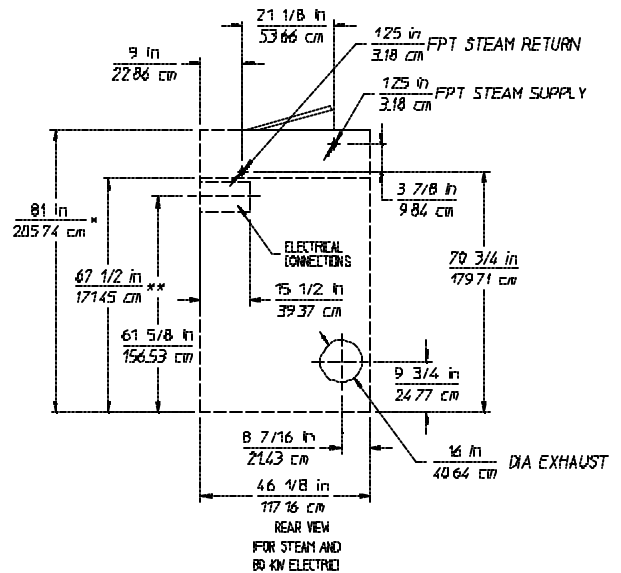
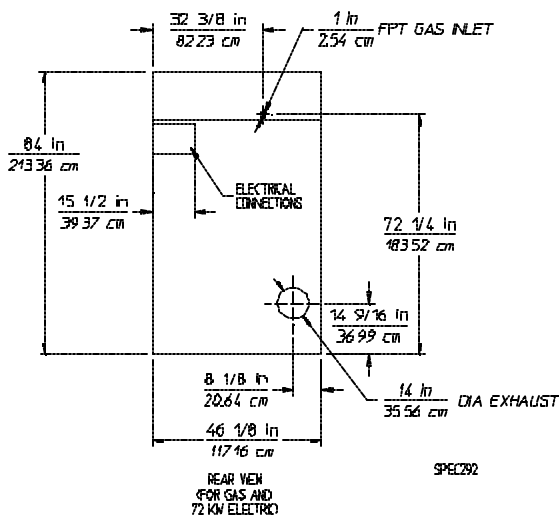
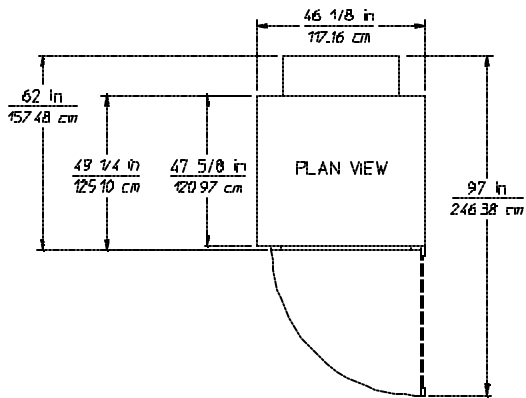

\* = OPERATING HEIGHT OF STEAM DRYER IS 84 in (214.4 cm)

\*\* = TOP SECTION CAN BE REMOVED FOR EASY INSTALLATION.

**NOTE:** ADC reserves the right to make changes in specifications at any time, without notice or obligation.

## B. COMPONENT IDENTIFICATION

### 1. Dryer Front View

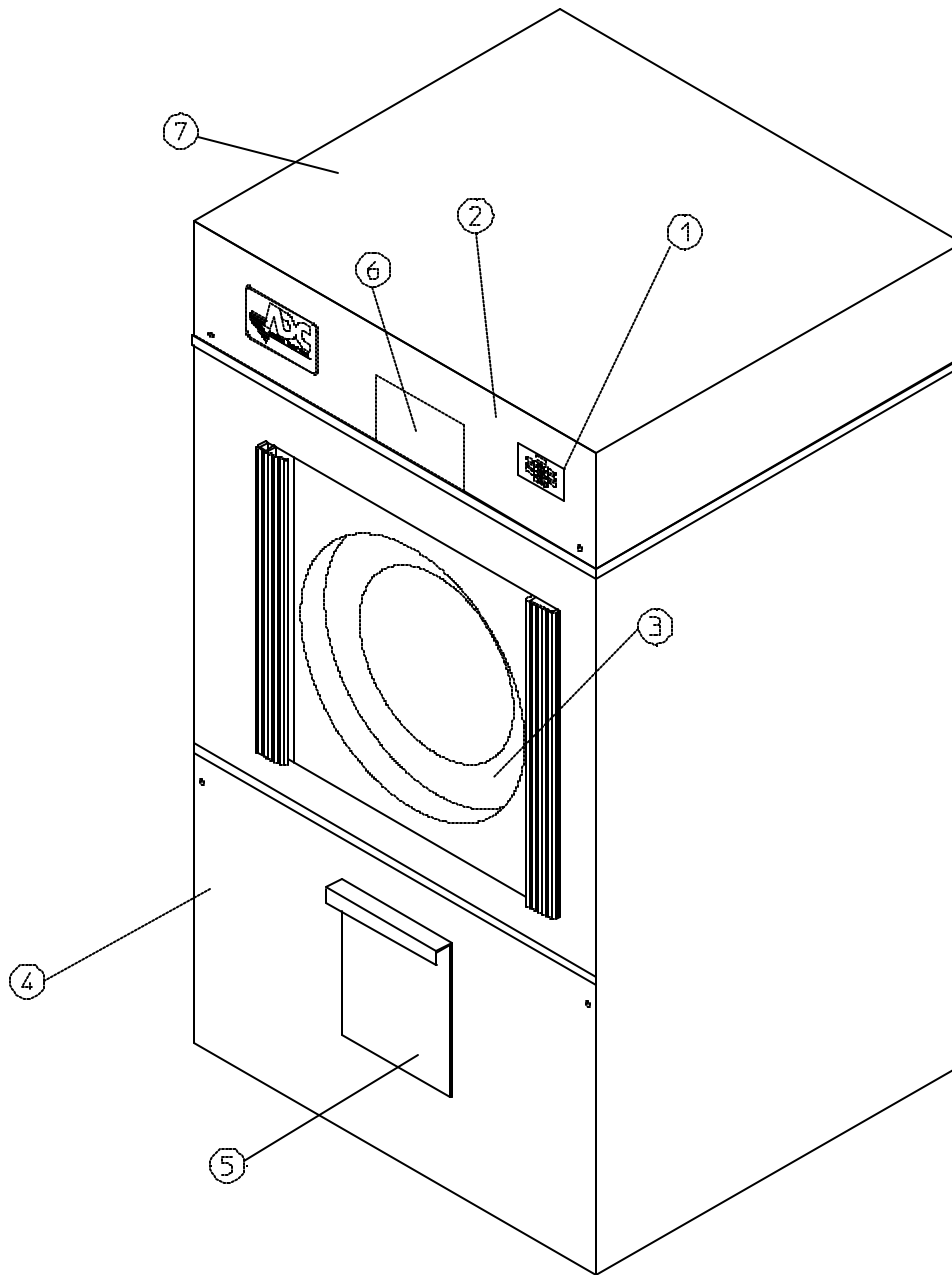

MAN2131

<u>Illus. No.</u>	<u>Description</u>
1	Microprocessor Control and Keyboard Panel Assembly (Controls)
2	Control (Top Access) Door Assembly
3	Main Door Assembly
4	Lint Door Assembly
5	Lint Drawer
6	Wire Diagram (located behind control door)
7	Top Console (module) Assembly

## 2. Dryer Rear View

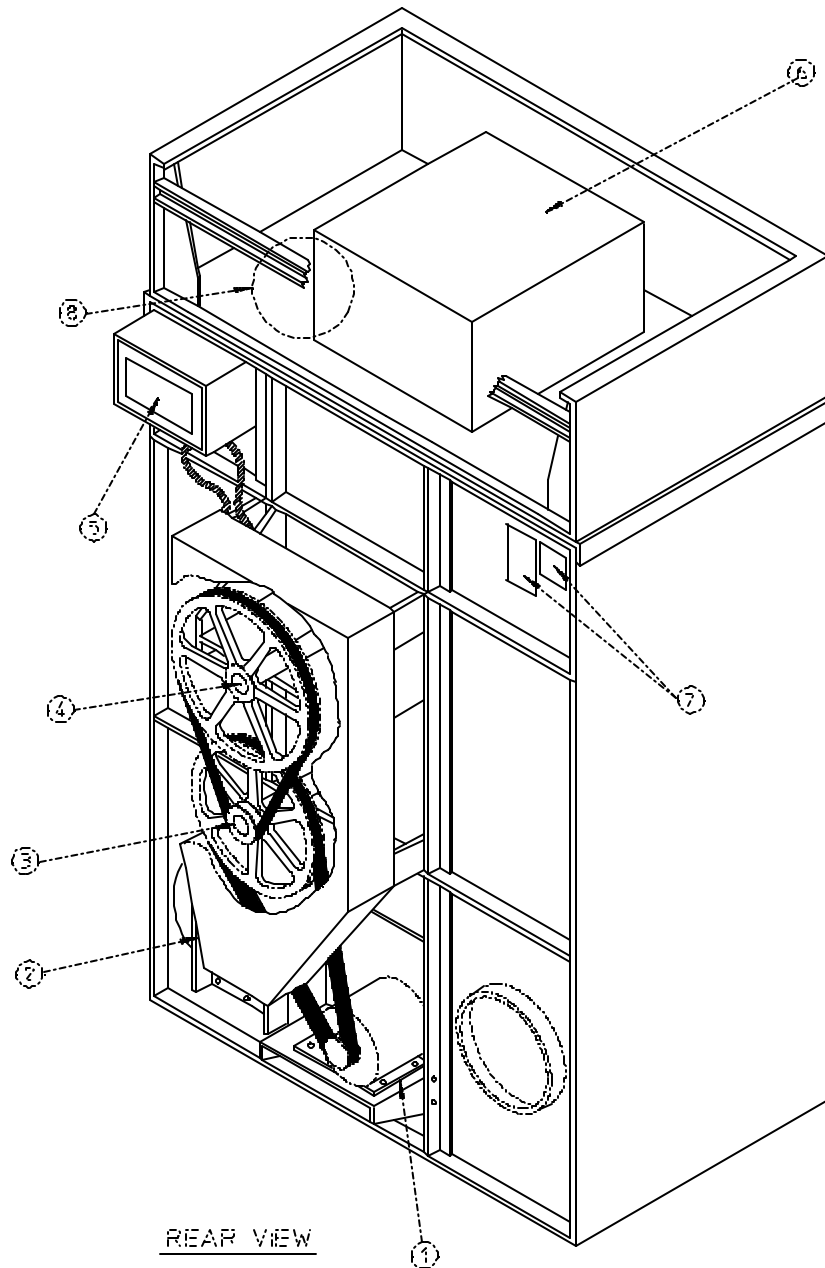

MAN0573

<u>Illus. No.</u>	<u>Description</u>
1	Basket (Drive) Motor Assembly
2	Blower Motor Mount Assembly (behind left guard)
3	Idler Bearing Mount Assembly
4	Tumbler Bearing Mount Assembly
5*	Electric Service Relay Box
6	Heating Unit
7	Data Label and Installation Label
8	1/8" Compressed Air Supply Inlet (for Steam Models Only)

\* Electric service connections are made in this box.

# SECTION III

## INSTALLATION PROCEDURES

Installation **should be** performed by competent technicians in accordance with local and state codes. In the absence of these codes, the installation **must conform** to applicable AMERICAN NATIONAL STANDARDS or in Canada, the installation **must conform** to applicable Canadian Standards: CAN/CGA-B149.1-M91 (Natural Gas) or CAN/CGA-B149.2-M91 (L.P. Gas) or LATEST EDITION (for General Installation and Gas Plumbing) or Canadian Electrical Codes Parts 1 & 2 CSA C22.1-1990 or LATEST EDITION (for Electrical Connections).

### A. LOCATION REQUIREMENTS

Before installing the dryer, be sure the location conforms to local codes and ordinances. In the absence of such codes or ordinances the location **must conform** with the National Fuel Gas Code ANSI.Z223.1-LATEST EDITION or applicable Canadian Standards: CAN/CGA-B149.1-M91 (Natural Gas) or CAN/CGA-B149.2-M91 (L.P. Gas) or LATEST EDITION (for General Installation and Gas Plumbing).

1. The dryer **must be** installed on a sound level floor capable of supporting its weight. It is recommended that carpeting be removed from the floor area that the dryer is to rest on.
2. The dryer **must not be** installed or stored in an area where it will be exposed to water and/or weather.
3. This dryer is for use in noncombustible locations.
4. Provisions for adequate air supply **must be** provided as noted in this manual (refer to **Fresh Air Supply** in **Section D**).
5. Clearance provisions **must be** made from combustible construction as noted in this manual (refer to **Dryer Enclosure Requirements** in **Section C**).
6. Provisions **must be** made for adequate clearances for servicing and for operation as noted in this manual (refer to **Dryer Enclosure Requirements** in **Section C**).
7. Dryer **must be** exhausted to the outdoors (refer to **Exhaust Requirements** in **Section E**).
8. Dryer **must be** located in an area where correct exhaust venting can be achieved as noted in the manual (refer to **Exhaust Requirements** in **Section E**).

**IMPORTANT:** Dryer *should be* located where a minimum amount of exhaust duct will be necessary.

## B. UNPACKING AND SETTING UP

Remove protective shipping material (i.e., plastic wrap and optional shipping box) from dryer.

**IMPORTANT:** Dryer *must be* transported and handled in an upright position at all times.

The dryer can be moved to its final location while still attached to the skid or with the skid removed. To unskid the dryer, locate and remove the four (4) lag bolts securing the base of the dryer to the wooden skid. Two (2) are located at the rear base (remove the back panel for access), and two (2) are located in the bottom of the lint chamber. To remove the two (2) lag bolts located in the lint chamber area, remove the lint drawer and the two (2) Phillips head screws securing lint door in place.

**NOTE:** Lint door **cannot** be removed totally from dryer due to a safety chain. The chain is secured to the dryer and door with special tamper proof screws. The safety chain **must not** be removed or cut from the lint door. Once these lag bolts are off, remove the eight (8) nuts and bolts holding the skid together and take the skid apart. The dryer can now be removed from the skid and set into place.

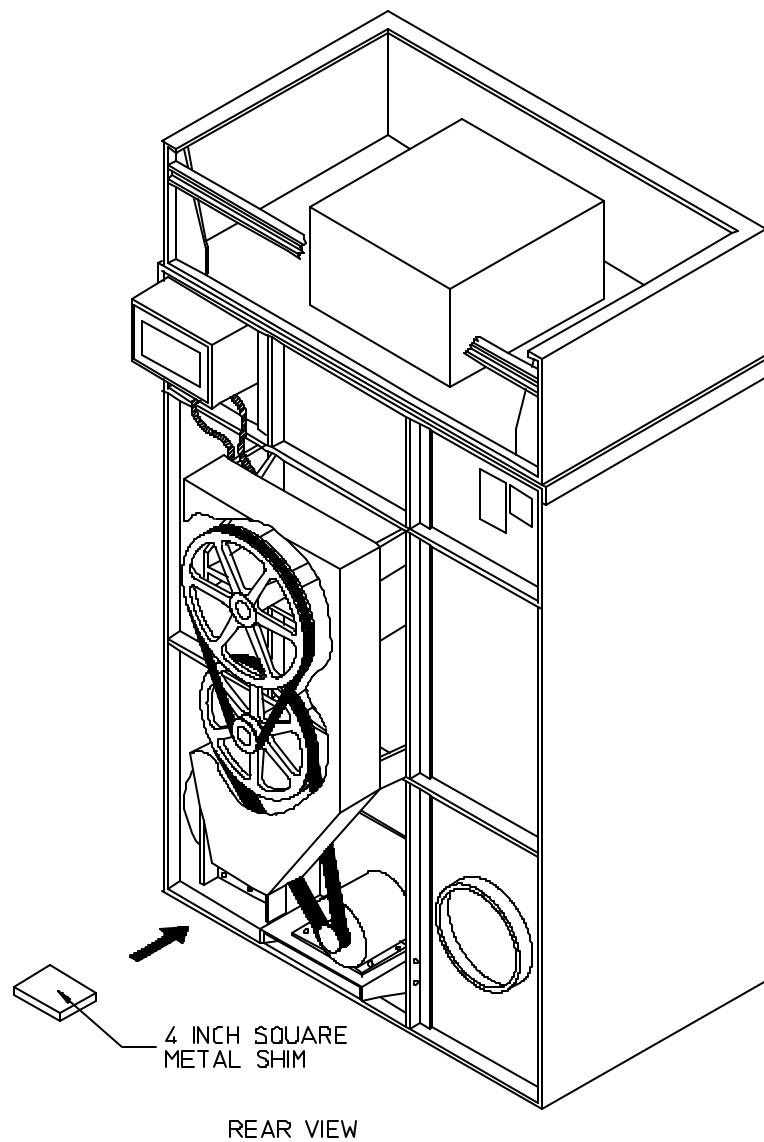

1. LEVELING DRYER

a. To level dryer, place 4-inch square metal shims (refer to illustration above) or other suitable material under the base pads. It is suggested that the dryer be tilted slightly to the rear.

2. The V-belts are disconnected from the basket drive motor for shipping. Reconnect V-belts before starting the dryer.

a. To Reconnect V-belts

- 1) Remove hardware holding back (belt) guard and remove guard from dryer.
- 2) Lay one (1) belt into motor sheave (pulley) groove and wind belt into corresponding groove of the idler pulley by rotating the idler pulley by hand. Rotate the idler pulley an extra turn or two to insure that the belt is tracking properly in the motor sheave (pulley) and idler pulley grooves without twisting.
- 3) Repeat procedure to reconnect the remaining belt.
- 4) Replace back (belt) guard and hardware.

3. If more headroom is needed when moving dryer into position, the top console (module) may be removed.

a. To remove top console (module)

- 1) Disconnect the ground wire (A) at the Rear Upper Left Hand Corner of Dryer.
- 2) Remove the six (6) set of nuts and washers (B) holding the console (module) to base.

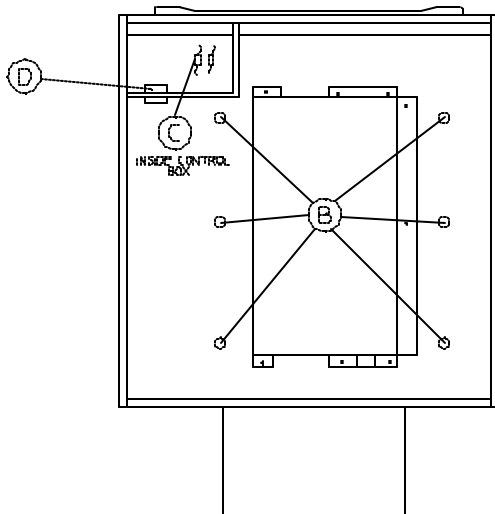

TOP (CUT-AWAY) VIEW

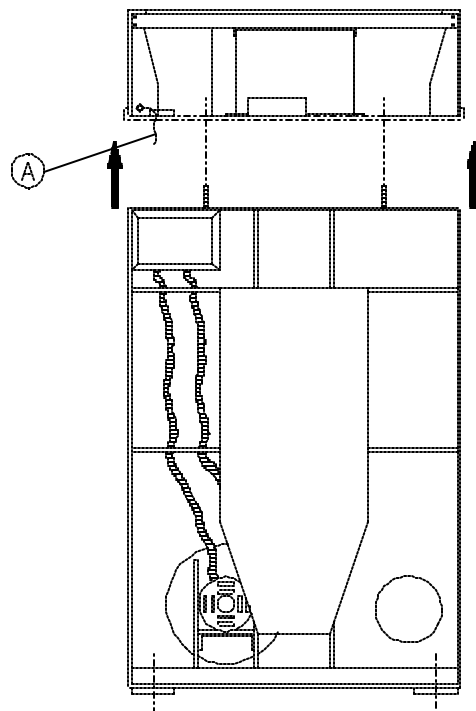

REAR VIEW

MAN0574



- 3) Open the control door and control panel, and disconnect the white 15-pin plug connector (refer to **C in the illustration on the previous page (page 12)** located in the base of the control box.
- 4) Disconnect white plug connector located outside backside of the control box (provides power to heat circuit).
- 5) Lift the console (module) off of the dryer base.

**IMPORTANT:** The dryer *must be* transported and handled in an upright position at all times.

### C. DRYER ENCLOSURE REQUIREMENTS

Even though a 12-inch clearance is acceptable, it is recommended that the rear of the dryer be positioned approximately two (2) feet (24 inches) from the nearest obstruction (i.e., wall) for ease of installation, maintenance, and service. Bulkheads and partitions should be made from noncombustible materials. The clearance between the bulkhead header and the dryer **must be** a minimum of 4 inches and **must not** extend more than 4-inches to the rear of the dryer front. The bulkhead facing **must not** be closed in all the way to the top of the dryer. A 2-inch clearance is required.

**NOTE:** Bulkhead facing *should not be* installed until after dryer is in place. Ceiling area *must be* located a minimum of 12 inches above the top of the dryer.

**IMPORTANT:** Even though a minimum of only 12-inches is required, 18-inches or more is suggested, for steam dryers and especially in cases where sprinkler heads are over the dryers.

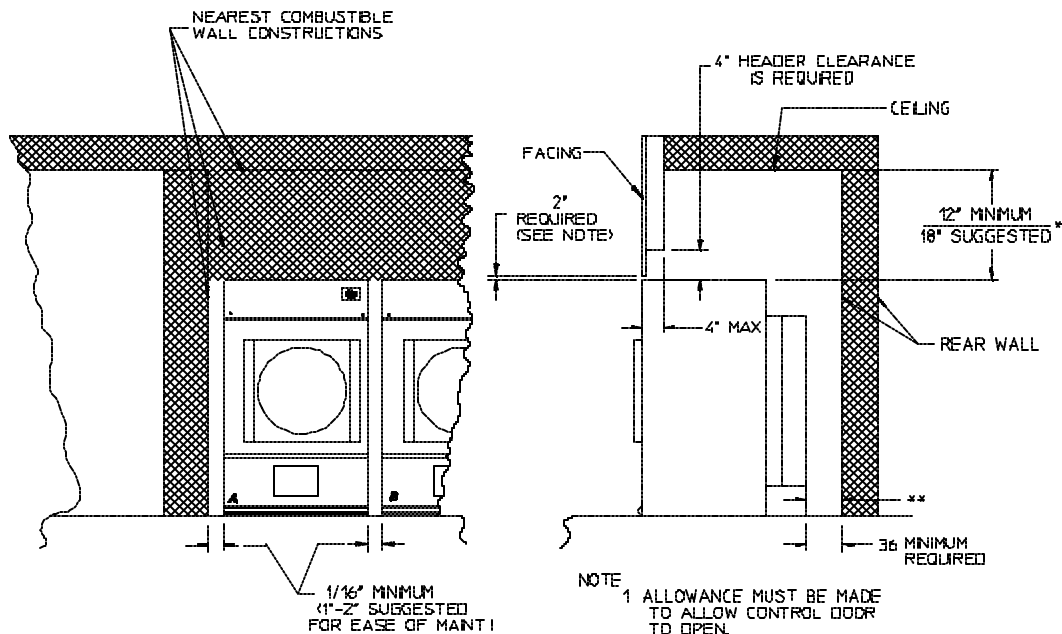

\* 12" OR MORE (18" OR MORE FOR STEAM) CLEARANCE IS SUGGESTED, ESPECIALLY IN CASES WHERE SPRINKLER HEADS ARE OVER THE DRYERS.

\*\* 24" MINIMUM PERMITTED FOR DRYERS VENTING HORIZONTALLY

11A43527

INSTALLATION- DRYER CLEARANCE TO ADJACENT WALL STRUCTURES

**NOTE:** When fire sprinkler systems are located above the dryers, a minimum of 18-inches above the dryer console (module) is suggested. Dryers may be positioned side wall to side wall however, 1 or 2 inches is suggested between dryers (or wall) for ease of installation and maintenance. Allowances *must be* made for the opening and closing of the control and lint doors.

**D. FRESH AIR SUPPLY**

When the dryer is operating, it draws in room air, heats it, passes this air through the basket (tumbler), and exhausts it out of the building. Therefore, the room air must be continually replenished from the outdoors. If the make-up air is inadequate, drying time and drying efficiency will be adversely affected. Ignition problems and sail switch "fluttering" problems may result, as well as premature motor failure from overheating.

Air supply (make-up air) must be given careful consideration to assure proper performance of each dryer. An unrestricted source of air is necessary for each dryer. An airflow of 2,100 cfm (cubic feet per minute) **must be** supplied to each gas dryer and electric dryer with a 72 Kw oven, 1,700 cfm to each electric dryer with a 60 Kw oven, 2,420 cfm to each electric dryer with a 80 Kw oven, and 2,750 cfm for each steam dryer. As a general rule, an unrestricted air entrance from the outdoors (atmosphere) of a minimum of three (3) square feet is required for each gas dryer and 72 Kw electric dryer and a minimum of five (5) square feet for each steam dryer.

To compensate for the use of registers or louvers used over the openings, this make-up air area **must be** increased by approximately thirty-three (33) percent. Make-up air openings **should not** be located in an area directly near where exhaust vents exit the building.

It is not necessary to have a separate make-up air opening for each dryer. Common make-up air openings are acceptable. However, they must be set up in such a manner that the make-up air is distributed equally to **ALL** the dryers.

**EXAMPLE:** For a bank of six (6) gas dryers, two (2) openings measuring 3 feet by 3 feet (9 square feet) is acceptable.

Allowances **must be** made for remote or constricting passageways or where dryers are located at excessive altitudes or predominantly low pressure areas.

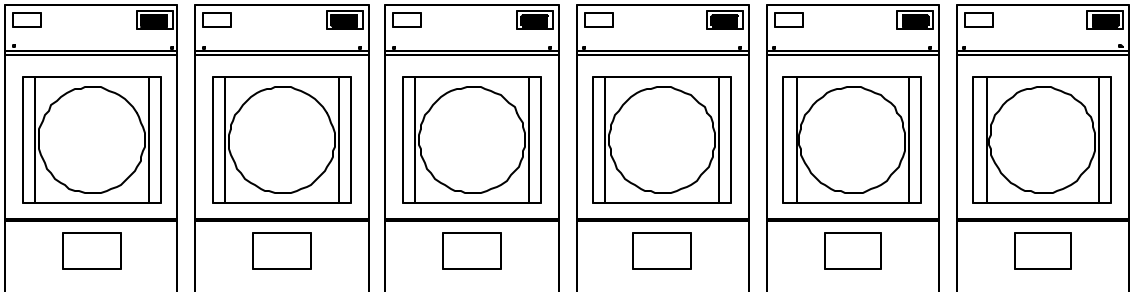

MAN1681

TYPICAL INSTALLATION SHOWING MAKE-UP AIR OPENINGS

**IMPORTANT:** Make-up air *must be* provided from a source free of dry cleaning solvent fumes. Make-up air that is contaminated by dry cleaning solvent fumes will result in irreparable damage to motors and other dryer components.

**NOTE:** Component failure due to dry cleaning solvent fumes will VOID THE WARRANTY.

## E. EXHAUST REQUIREMENTS

### 1. GENERAL EXHAUST DUCT WORK INFORMATION

Exhaust duct work **should be** designed and installed by a qualified professional. Improperly sized duct work will create excessive back pressure which results in slow drying, increased use of energy, overheating of the dryer, and shutdown of the burner by the airflow (sail) switches, burner hi-limits, or basket (tumbler) hi-heat thermostats.

**CAUTION:** DRYER *MUST BE* EXHAUSTED TO THE OUTDOORS.

**CAUTION:** IMPROPERLY SIZED OR INSTALLED EXHAUST DUCT WORK CAN CREATE A POTENTIAL FIRE HAZARD.

**NOTE:** When a dryer is exhausted separately, it is recommended that a back draft damper be installed.

**NOTE:** When dryers are exhausted into a multiple (common) exhaust line, each dryer *must be* supplied with a back draft damper.

The exhaust duct work **should be** laid out in such a way that the duct work travels as directly as possible to the outdoors with as few turns as possible. Single or independent dryer venting is recommended.

When single dryer venting is used, the duct work from the dryer to the outside exhaust outlet **should not** exceed twenty (20) feet. In the case of multiple (common) dryer venting, the distance from the last dryer to the outside exhaust outlet **should not** exceed twenty (20) feet. The shape of the duct work is not critical so long as the minimum cross section area is provided. It is suggested that the use of 90° turns in ducting be avoided; use 30° or 45° angles instead. The radius of the elbows should preferably be 1-1/2 times the diameter of the duct. Excluding basket and dryer elbow connections or elbows used for outside protection from the weather, no more than two (2) elbows **should be** used in the exhaust duct run. If more than two (2) elbows are used, the cross section area of the duct work **must be** increased in proportion to number of elbows added.

**ALL** duct work **should be** smooth inside with no projections from sheet metal screws or other obstructions which will collect lint. When adding ducts, the ducts to be added should overlap the duct to which it is connected. **ALL** duct work joints **must be** taped to prevent moisture and lint from escaping into the building. Additionally, inspection doors **should be** installed at strategic points in the exhaust duct work for periodic inspection and clean-out of lint from the duct work.

**IMPORTANT:** Exhaust back pressure measured by a manometer at the dryer exhaust duct area **must not** exceed 0.3 inches of water column.

**NOTE:** Where the exhaust duct work passes through a wall, ceiling, or roof made of combustible materials, the opening **must be** 2 inches larger (all the way around) than the duct. The duct **must be** centered within this opening.

a. Outside Duct Work Protection

- 1) To protect the outside end of horizontal duct work from the weather, a 90° elbow bent downward **should be** installed where the exhaust exits the building. If the exhaust duct work travels vertically up through the roof, it **should be** protected from the weather by using a 180° turn to point the opening downward. In either case, allow at least twice the diameter of the duct between the duct opening and the nearest obstruction.

**IMPORTANT:** **DO NOT** use screens or caps on the outside of opening of exhaust duct work.

VERTICAL DUCTING

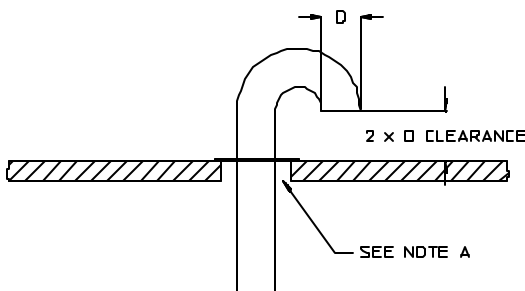

HORIZONTAL DUCTING

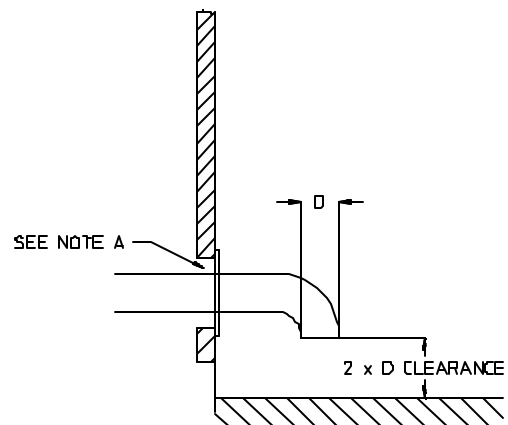

NOTE "A": OPENING MUST BE TWO (2) INCHES LARGER THAN DUCT (ALL THE WAY AROUND) THE DUCT MUST BE CENTERED WITHIN THIS OPENING

MAN0731

## 2. SINGLE DRYER VENTING

Where possible, it is suggested to provide a separate exhaust duct for each dryer. The exhaust duct **should be** laid out in such a way that the duct work travels as directly as possible to the outdoors with as few turns as possible. It is suggested that the use of 90° turns in ducting be avoided; use 30° or 45° angles instead. The shape of the exhaust duct work is not critical so long as the minimum cross section area is provided.

**IMPORTANT:** Minimum duct size for a gas dryer or 72 Kw electric dryer is 14-inches for a round duct or 12.50" for a square duct. The minimum duct size for a steam dryer or 80 Kw electric dryer is 16-inches for a round duct or 14.50" x 14.50" for a square duct. Duct size **must not** be reduced anywhere down stream of dryer.

**IMPORTANT:** Exhaust back pressure measured by a manometer at each basket (tumbler) exhaust duct area **should not** exceed 0.3 inches of water column.

It is suggested that the duct work from each dryer (minimum 14 inches for a gas dryer or 72 Kw electric dryer and 16 inches for a steam dryer or 80 Kw electric dryer) not exceed twenty (20) feet with no more than two (2) elbows (excluding dryer connections and outside exhaust outlets). If the duct work exceeds twenty (20) feet or has numerous elbows, the cross section area of the duct work **must be** increased in proportion to the length and number of elbows in it. In calculating duct size, the cross section area of a square or rectangular duct **must be** increased by twenty (20) percent for each additional twenty (20) feet. The diameter of a round exhaust duct **should be** increased ten (10) percent for each additional fifteen (15) feet. Each 90° elbow is equivalent to an additional thirty (30) feet, and each 45° elbow is equivalent to an additional fifteen (15) feet.

### SINGLE DRYER VENTING

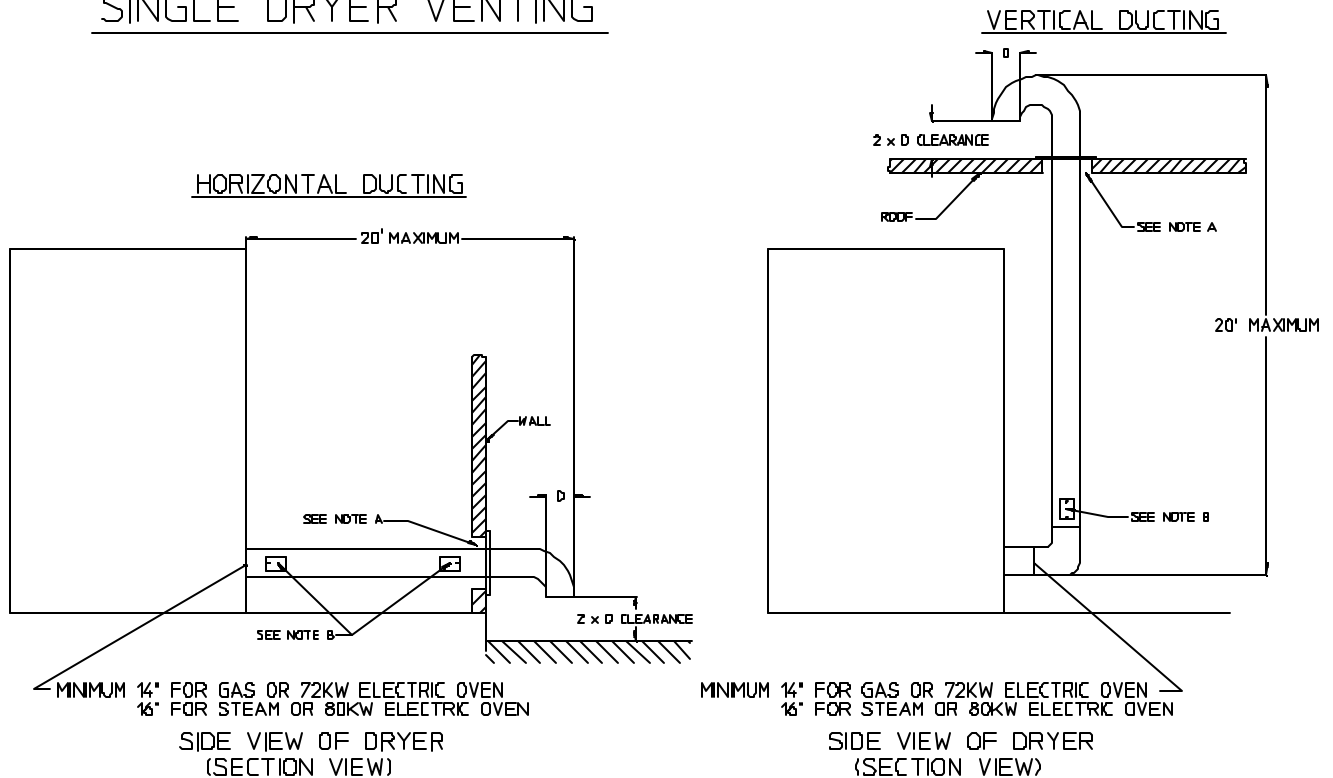

NOTE: \*A\*- OPENING MUST BE TWO (2) INCHES LARGER THAN DUCT (ALL THE WAY AROUND)  
THE DUCT MUST BE CENTERED WITHIN THIS OPENING  
\*B\*- INSPECTION DOORS SHOULD BE INSTALLED AT STRATEGIC POINTS FOR PERIODIC INSPECTION AND CLEANING

MAN4364

**IMPORTANT:** For extended duct work runs, the cross section area of the duct can only be increased to an extent. Maximum proportional duct work runs **cannot** exceed twenty (20) feet more than the original limitations of twenty (20) feet with two (2) elbows. When the duct work approaches the maximum limits as noted in this manual, a professional heating venting air conditioning (HVAC) firm **should be** consulted for proper venting information.

**ALL** duct work **should be** smooth inside with no projections from sheet metal screws or other obstructions which will collect lint. When adding ducts, the duct to be added should overlap the duct to which it is to be connected. **ALL** duct work joints **must be** taped to prevent moisture and lint from escaping into the building. Inspection doors **should be** installed at strategic points in the exhaust duct work for periodic inspection and clean-out of lint from the duct work.

**NOTE:** Where the exhaust duct passes through a wall, ceiling, or roof made of combustible materials, the opening **must be** 2 inches larger (all the way around) than the duct. The duct **must be** centered within this opening.

a. Outside Duct Work Protection

- 1) To protect the outside end of horizontal duct work from the weather, a 90° elbow bent downward **should be** installed where the exhaust exits the building. If the exhaust duct work travels vertically up through the roof, it **should be** protected from the weather by using a 180° turn to point the opening downward. In either case, allow at least twice the diameter of the duct between the duct opening and nearest obstruction.

**IMPORTANT:** **DO NOT** use screens, louvers, or caps on the outside of opening of exhaust duct work.

### 3. MULTIPLE DRYER (COMMON) VENTING

If it is not feasible to provide separate exhaust ducts for each dryer, ducts from individual dryers may be channeled into a "common main duct." The individual ducts should enter the bottom or side of the main duct at an angle not more than 45° in the direction of air flow and **should be** spaced at least 46-1/8" apart. The main duct **should be** tapered, with the diameter increasing before each individual 14-inch (minimum for gas dryers or 72 Kw electric dryers) or 16-inch (minimum for steam dryers) duct is added.

**IMPORTANT:** The AD-115 *is not* provided with a back draft damper. When exhausted into a multiple (common) exhaust line, a back draft damper **must be** installed at each dryer duct.

**IMPORTANT:** No more than four (4) dryers **should be** connected to one main common duct.

The main duct may be any shape or cross sectional area, so long as the minimum cross section area is provided. The **illustrations** on **pages 20** and **21** show the minimum cross section area for multiple dryer round or square venting. These figures must be increased 10 square inches when rectangular main ducting is used, and the ratio of duct width to depth **should not** be greater than 3-1/2 to 1. These figures **must be** increased in proportion if the main duct run to the last dryer to where it exhausts to the outdoors is unusually long (over twenty [20] feet) or has numerous elbows (more than two [2]) in it. In calculating duct work size, the cross section area of a square or rectangular duct **must be** increased twenty (20) percent for each additional twenty (20) feet. The diameter of a round exhaust **must be** increased ten (10) percent for each additional twenty (20) feet. Each 90° elbow is equivalent to an additional fifteen (15) feet.

**IMPORTANT:** For extended duct work runs, the cross section area of the duct work can only be ~~increased to a extent~~. **Maximum proportional duct work runs cannot** exceed twenty (20) feet more than the original limitations of twenty (20) feet with two (2) elbows. When the duct work approaches the maximum limits as noted in this manual, a professional HVAC firm *should be* consulted for proper venting information.

**IMPORTANT:** Exhaust back pressure measured by a manometer at each dryer exhaust duct area *should not* exceed 0.3 inches of water column.

The duct **should be** smooth inside with no projections from sheet metal screws or other obstructions which will collect lint. When adding ducts, the duct to be added should overlap the duct to which it is to be connected. **ALL** duct work joints **must be** taped to prevent moisture and lint from escaping into the building. Inspection doors **should be** installed at strategic points in the exhaust duct work for periodic inspection and clean-out of lint from the duct work.

**NOTE:** Where the exhaust passes through a wall, ceiling, or roof made of combustible materials, the opening *must be* 2 inches larger (all the way around) than the duct. The duct *must be* centered within this opening.

a. Outside Duct Work Protection

- 1) To protect the outside end of horizontal duct work from the weather, a 90° elbow bent downward **should be** installed where the exhaust exits the building. If the exhaust duct work travels vertically up through the roof, it **should be** protected from the weather by using a 180° turn to point the opening downward. In either case, allow at least twice the diameter of the duct between the duct opening and nearest obstruction.

**IMPORTANT:** *DO NOT* use screens, louvers, or caps on the outside of opening of exhaust duct work

MULTIPLE DRYER VENTING (ADG-115 AND ADE-115 WITH 72 KW OVEN)  
WITH 12" DIAMETER (2100 CFM) EXHAUST CONNECTIONS AT COMMON DUCT

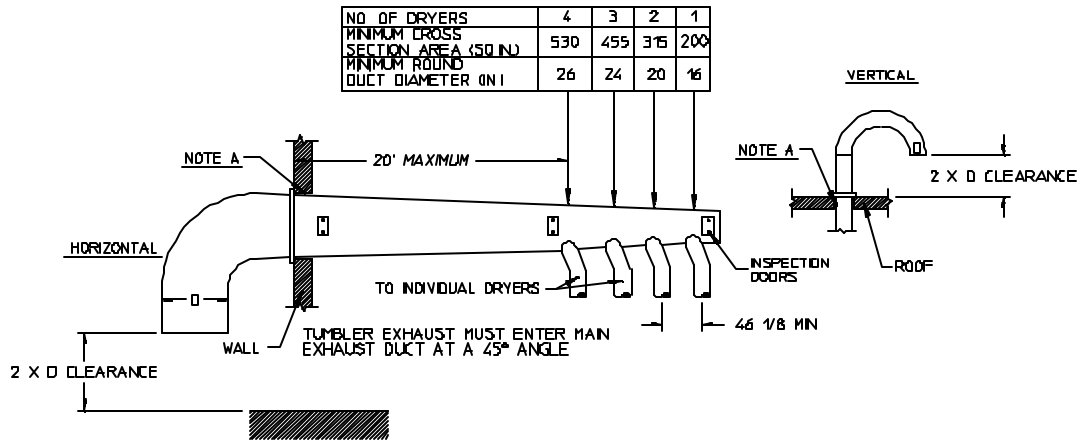

IMPORTANT NO MORE THAN 4 DRYERS CAN BE CONNECTED TO ONE COMMON DUCT (VENT)

FORMULAS TO CALCULATE DUCTING CROSS SECTIONAL AREA

CROSS SECTIONAL AREA OF A ROUND DUCT =  $785 \times D^2$  WHERE D = DIAMETER OF THE DUCT

CROSS SECTIONAL AREA OF A RECTANGULAR DUCT =  $W \times H$  WHERE W = WIDTH AND H = HEIGHT

NOTE A: OPENING MUST BE TWO (2) INCHES LARGER THAN DUCT (ALL THE WAY AROUND). THE DUCT MUST BE CENTERED WITHIN THIS OPENING

MAN1620

MULTIPLE DRYER VENTING (ADE-115 WITH 60 KW OVEN)  
WITH 12" DIAMETER (1700 CFM) EXHAUST CONNECTIONS AT COMMON DUCT

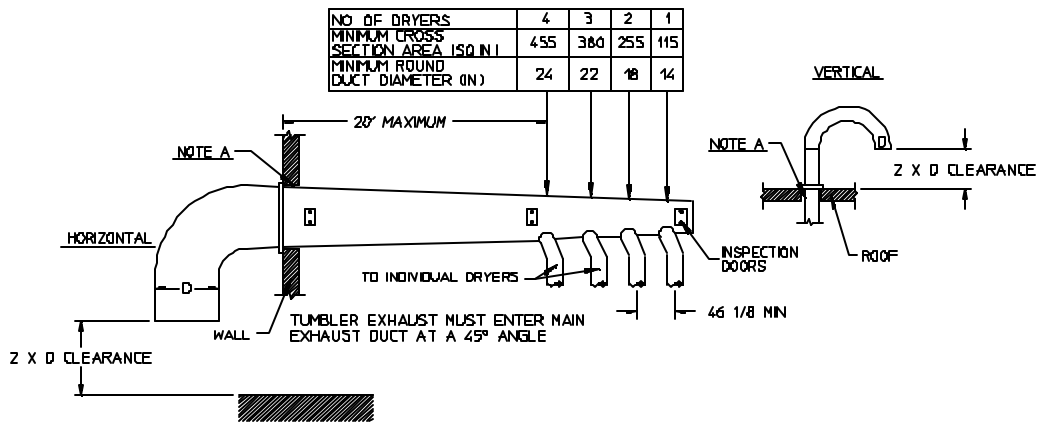

IMPORTANT NO MORE THAN 4 DRYERS CAN BE CONNECTED TO ONE COMMON DUCT (VENT)

FORMULAS TO CALCULATE DUCTING CROSS SECTIONAL AREA

CROSS SECTIONAL AREA OF A ROUND DUCT =  $785 \times D^2$  WHERE D = DIAMETER OF THE DUCT

CROSS SECTIONAL AREA OF A RECTANGULAR DUCT =  $W \times H$  WHERE W = WIDTH AND H = HEIGHT

NOTE A: OPENING MUST BE TWO (2) INCHES LARGER THAN DUCT (ALL THE WAY AROUND) THE DUCT MUST BE CENTERED WITHIN THIS OPENING.

MAN1618



MULTIPLE DRYER VENTING (ADE-115 WITH 80 KW OVEN)  
WITH 12" DIAMETER (2420 CFM) EXHAUST CONNECTIONS AT COMMON DUCT

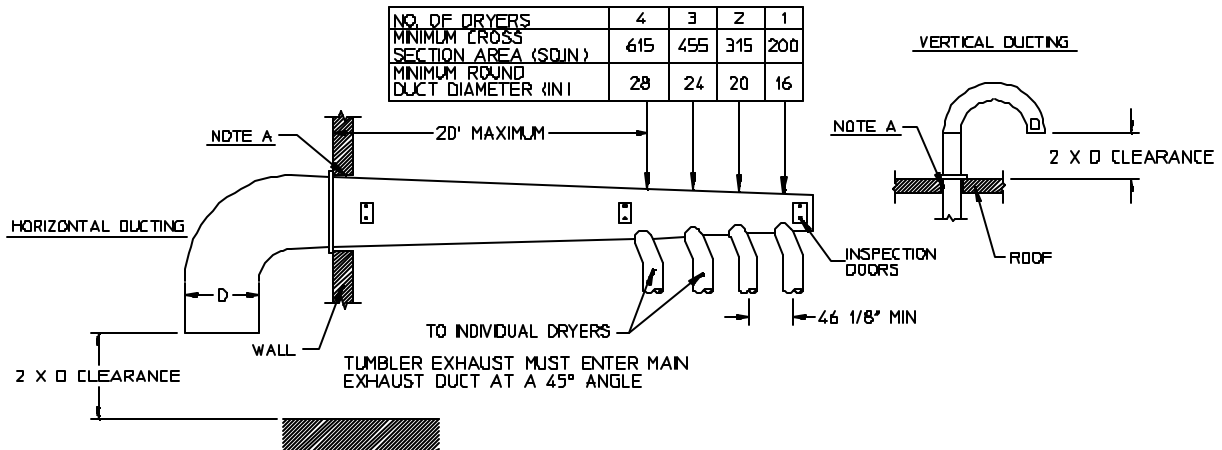

IMPORTANT, NO MORE THAN 4 DRYERS CAN BE CONNECTED TO ONE COMMON DUCT ( VENT )

FORMULAS TO CALCULATE DUCTING CROSS SECTIONAL AREA

CROSS SECTIONAL AREA OF A ROUND DUCT =  $.785 \times D^2$  WHERE D = DIAMETER OF THE DUCT.

CROSS SECTIONAL AREA OF A RECTANGULAR DUCT =  $W \times H$  WHERE W = WIDTH AND H = HEIGHT.

NOTE A OPENING MUST BE TWO (2) INCHES LARGER THAN DUCT (ALL THE WAY AROUND) THE DUCT MUST BE CENTERED WITHIN THIS OPENING.

MAN1644

MULTIPLE DRYER VENTING (ADS-115)  
WITH 16" DIAMETER (3000 CFM) EXHAUST CONNECTIONS AT COMMON DUCT

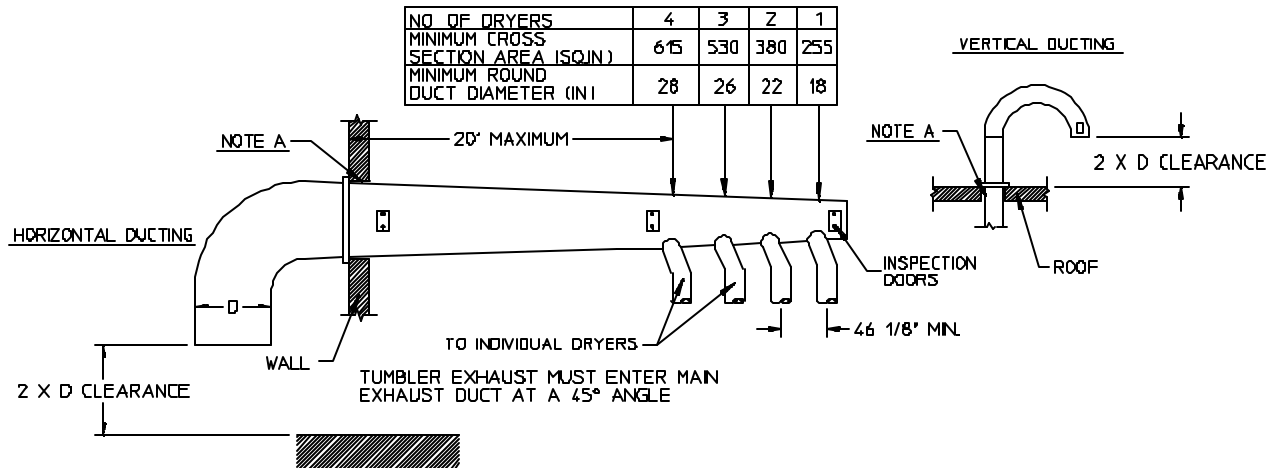

IMPORTANT, NO MORE THAN 4 DRYERS CAN BE CONNECTED TO ONE COMMON DUCT ( VENT )

FORMULAS TO CALCULATE DUCTING CROSS SECTIONAL AREA

CROSS SECTIONAL AREA OF A ROUND DUCT =  $.785 \times D^2$  WHERE D = DIAMETER OF THE DUCT.

CROSS SECTIONAL AREA OF A RECTANGULAR DUCT =  $W \times H$  WHERE W = WIDTH AND H = HEIGHT.

NOTE A OPENING MUST BE TWO (2) INCHES LARGER THAN DUCT (ALL THE WAY AROUND) THE DUCT MUST BE CENTERED WITHIN THIS OPENING

MAN1617

## F. ELECTRICAL INFORMATION

### 1. Electrical Requirements

It is your responsibility to have **ALL** electrical connections made by a properly licensed and competent electrician to assure that the electrical installation is adequate and conforms with local and state regulations or codes. In the absence of such codes, **ALL** electrical connections, material, and workmanship **must conform** to the applicable requirements of the National Electrical Code ANSI/NFPA NO.70-LATEST EDITION or in Canada, the installation **must conform** to applicable Canadian Standards: Canadian Electrical Codes Parts 1 & 2 CSA C22.1-1990 or LATEST EDITION (for Electrical Connections).

**IMPORTANT:** Failure to comply with these codes or ordinances, and the requirements stipulated in this manual can result in personal injury or component failure.

**NOTE:** Component failure due to improper installation will VOID THE WARRANTY.

Each dryer **should be** connected to an independently protected branch circuit. The dryer **must be** connected with copper wire **ONLY**. **DO NOT** use aluminum wire which could cause a fire hazard. The copper conductor wire and cable **must be** of proper ampacity and insulation in accordance with electric codes for making **ALL** service connections.

**NOTE:** The use of aluminum wire will VOID THE WARRANTY.

2. Electrical Service Specifications

# ADG-115 Reversing, 3Ø Motor (Gas) ADS-115 Reversing, 3Ø Motor (Steam)

## ELECTRICAL SERVICE SPECIFICATIONS (PER DRYER)

**IMPORTANT:** 208 VAC and 230/240 VAC **ARE NOT THE SAME**. When ordering, *specify exact voltage*.

- NOTES:**
- A. Fuse ratings are dual-element, time-delay, current limiting, class RK1 or RK5 **ONLY**.
  - B. Circuit breakers are thermal magnetic (industrial) type **ONLY**. For others, calculate/verify correct breaker size according to appliance amp draw rating and type of breaker used.
  - C. Circuit breakers for 3Ø dryers **must be** 3-pole type.

SERVICE VOLTAGE	PHASE	WIRE SERVICE	APPROX. AMP DRAW		MINIMUM WIRE SIZE*	FUSING	CIRCUIT BREAKER
			60 Hz	50 Hz		Dual Element Time Delay	
208	3Ø	3/4	13	15	12	20	25
230	3Ø	3	13	15	12	20	25
380	3Ø	3/4	8	8	14	12	15
416	3Ø	3/4	---	8	14	12	15
440	3Ø	3/4	8	10	14	12	15
460	3Ø	3/4	7	---	14	12	15
480	3Ø	3/4	6	---	14	12	15

\* AWG Stranded Type Wire...for individual lengths less than 100 feet.

**IMPORTANT:** The dryer **must be** connected to the electric supply shown on the data label that is affixed to the back of the dryer, at the upper right hand corner. In the case of 208 VAC or 230/240 VAC, the supply voltage **must match** the electric service specifications of the data label **exactly**.

**WARNING:** 208 VAC and 230/240 Volts **ARE NOT THE SAME**. Any damage done to dryer components due to improper voltage connections will automatically **VOID THE WARRANTY**.

**NOTE:** ADC reserves the right to make changes in specifications at any time, without notice or obligation.

## ADE-115 (60 Kw Electric Oven) Reversing, 3Ø Motor

### ELECTRICAL SERVICE SPECIFICATIONS (PER DRYER)

**IMPORTANT:** 208 VAC and 230/240 VAC **ARE NOT THE SAME**. When ordering *specify exact voltage*.

- NOTES:** A. Fuse ratings are dual element-time delay-current limiting, class RK1 or RK5 ONLY.  
 B. Circuit breakers are thermal magnetic (industrial) type **ONLY**. For others, calculate/verify correct breaker size according to appliance amp draw rating and type of breaker used.  
 C. Circuit breakers for 3Ø dryers **must be** 3-pole type.

OVEN SIZE (Kw)	SERVICE VOLTAGE	PHASE	WIRE SERVICE	APPROX. AMP DRAW		MINIMUM WIRE SIZE*	FUSING	CIRCUIT BREAKER
				50 Hz	60 Hz		Dual Element Time Delay	
60	208	3Ø	3	---	180	3/0	250	250
60	240	3Ø	3	159	157	2/0	200	200
60	380	3Ø	3	99	---	3	150	150
60	380	3Ø	4	99	---	3	150	150
60	416	3Ø	3	91	---	3	150	150
60	416	3Ø	4	91	---	3	150	150
60	480	3Ø	3	---	82	4	100	100
60	480	3Ø	4	---	82	4	100	100
60	575/600	3Ø	3 / 4	---	86	4	90	90

\* AWG Stranded Type Wire ... for individual lengths less than 100 feet.  
 (Motor lead type wire is recommended)

**IMPORTANT:** The dryer **must be** connected to the electric supply shown on the data label that is affixed to the back of the dryer, at the upper right hand corner. In the case of 208 VAC or 230/240 VAC, the supply voltage **must match** the electric service specifications of the data label **exactly**.

**WARNING:** 208 VAC and 230/240 Volts **ARE NOT THE SAME**. Any damage done to dryer components due to improper voltage connections will automatically **VOID THE WARRANTY**.

**NOTE:** ADC reserves the right to make changes in specifications at any time, without notice or obligation.

## ADE-115 (72 Kw Electric Oven) Reversing, 3Ø Motor

### ELECTRICAL SERVICE SPECIFICATIONS (PER DRYER)

**IMPORTANT:** 208 VAC and 230/240 VAC **ARE NOT THE SAME**. When ordering, *specify exact voltage*.

- NOTES:** A. Fuse ratings are dual element-time delay-current limiting, class RK1 or RK5 **ONLY**.  
 B. Circuit breakers are thermal magnetic (industrial) type **ONLY**. For others, calculate/verify correct breaker size according to appliance amp draw rating and type of breaker used.  
 C. Circuit breakers for 3Ø dryers **must be** 3-pole type.

OVEN SIZE (Kw)	SERVICE VOLTAGE	PHASE	WIRE SERVICE	APPROX. AMP DRAW		MINIMUM WIRE SIZE*	FUSING	CIRCUIT BREAKER
				50 Hz	60 Hz		Dual Element Time Delay	
72	208	3Ø	3	---	213	4/0	300	300
72	240	3Ø	3	188	186	3/0	250	250
72	380	3Ø	3	117	---	1	150	150
72	380	3Ø	4	117	---	1	150	150
72	416	3Ø	3	108	---	2	150	150
72	416	3Ø	4	108	---	2	150	150
72	480	3Ø	3	---	97	3	150	125
72	480	3Ø	4	---	97	3	150	125
72	575/600	3Ø	3/4	---	78	4	100	110

\* AWG Stranded Type Wire ... for individual lengths less than 100 feet.  
 (Motor lead type wire is recommended)

**IMPORTANT:** The dryer ***must be*** connected to the electric supply shown on the data label that is affixed to the back of the dryer, at the upper right hand corner. In the case of 208 VAC or 230/240 VAC, the supply voltage ***must match*** the electric service specifications of the data label **exactly**.

**WARNING:** 208 VAC and 230/240 Volts **ARE NOT THE SAME**. Any damage done to dryer components due to improper voltage connections will automatically **VOID THE WARRANTY**.

**NOTE:** ADC reserves the right to make changes in specifications at any time, without notice or obligation.

# ADE-120ES (80 Kw Electric Oven) Reversing, 3Ø Motor

## ELECTRICAL SERVICE SPECIFICATIONS (PER DRYER)

**IMPORTANT:** 208 VAC and 230/240 VAC ARE NOT THE SAME. When ordering, *specify exact voltage*.

- NOTES:** A. Fuse ratings are dual element-time delay-current limiting, class RK1 or RK5 **ONLY**.  
 B. Circuit breakers are thermal magnetic (industrial) type **ONLY**. For others, calculate/verify correct breaker size according to appliance amp draw rating and type of breaker used.  
 C. Circuit breakers for 3Ø dryers **must be** 3-pole type.

OVEN SIZE (KW)	SERVICE VOLTAGE	PHASE	WIRE SERVICE	APPROX. AMP DRAW		MINIMUM WIRE SIZE*	FUSING	CIRCUIT BREAKER
				50 Hz	60 Hz		Dual Element Time Delay	
80	208	3Ø	3	---	235	250 MCM	300	300
80	240	3Ø	3	208	206	4/0	300	300
80	380	3Ø	3	130	---	1	175	175
80	380	3Ø	4	130	---	1	175	175
80	416	3Ø	3	119	---	1	150	150
80	416	3Ø	4	119	---	1	150	150
80	480	3Ø	3	---	107	2	150	150
80	480	3Ø	4	---	107	2	150	150
80	575	3Ø	3/4	---	86	3	125	125
80	600	3Ø	3/4	---	85	3	125	125

\* AWG Stranded Type Wire ... for individual lengths less than 100 feet.  
 (Motor lead type wire is recommended)

**IMPORTANT:** The dryer *must be* connected to the electric supply shown on the data label that is affixed to the back of the dryer, at the upper right hand corner. In the case of 208 VAC or 230/240 VAC, the supply voltage *must match* the electric service specifications of the data label exactly.

**WARNING:** 208 VAC and 230/240 Volts ARE NOT THE SAME. Any damage done to dryer components due to improper voltage connections will automatically VOID THE WARRANTY.

**NOTE:** ADC reserves the right to make changes in specifications at any time, without notice or obligation.

### 3. Electrical Connections

**NOTE:** A wiring diagram is included with each dryer and is affixed to the rear upper right guard panel of the dryer.

The only electrical input connections to the dryer are the 3-phase (3 $\phi$ ) power leads (L1, L2, and L3), GROUND, and in the case of 4 wire service, the neutral. These electrical connections are made at the wire leads located in the electric service and relay box at the rear, upper left hand corner of the dryer. To gain access into this service box, the service cover **must be** removed.

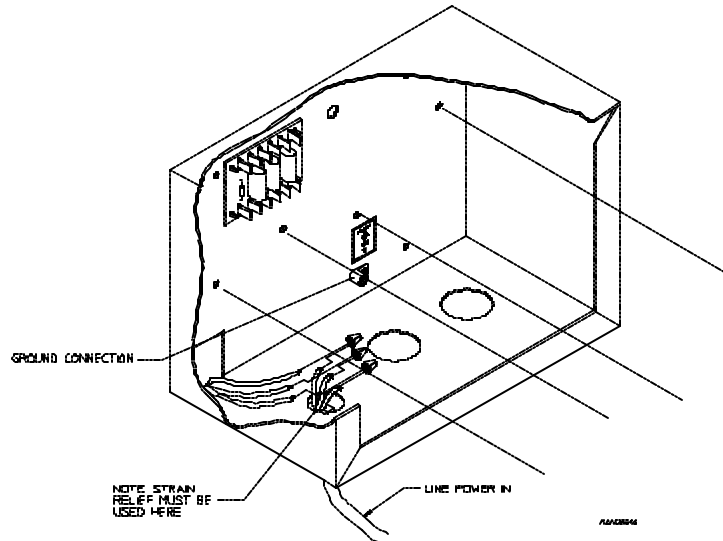

Providing local codes permit, power connections to the dryer can be made by the use of a flexible underwriters laboratory listed cord and pigtail (wire size **must conform** to rating of the dryer), or the dryer can be hard wired directly to the service breaker. In **ALL** cases, a strain relief **must be** used where the wires enter the dryer electrical service (relay) box.

#### a. Gas Models and Steam Models Dryers

These electrical connections are made at the terminal block located in the electric service/relay box at the rear, upper left hand corner of the dryer. To gain access into this service box, the service cover (upper back guard) **must be** removed.

#### b. Electric Model Dryers

For electric model dryers made to operate at 208 VAC, 230 VAC, or 240 VAC, the electrical input connection is made into the terminal block located at the upper rear of the dryer. For electric model dryers made to operate at 380 VAC, 416 VAC, 440 VAC, or 480 VAC, the electrical input connection is made to the oven relay located at the upper rear of the dryer. Input connection wiring **must be** sized properly to handle the dryer's current draw. This information is printed on the dryer's data label which is affixed to the rear, upper right hand corner of the dryer.

**NOTE:** A CIRCUIT SERVING EACH DRYER **MUST BE** PROVIDED.

#### 4. Grounding

Grounding (earth) connections **must be** provided and installed in accordance with state and local codes. In the absence of the codes, grounding **must conform** to applicable requirements of the National Electric Code ANSI/NFPA NO.70 LATEST EDITION, or in CANADA, the Canadian Electrical Codes Parts 1 and 2 CSA C22.1-1990 or LATEST EDITION. The ground connection may be to a proven earth ground at the location service panel.

**NOTE:** A grounding connection (terminal lug) is provided in the dryer's electrical service and relay box at the rear, upper left hand corner of the dryer.

For added personal safety, when possible, it is suggested that a separate ground wire (sized per local codes) be connected from the ground connection of the dryer to a grounded cold water pipe. **DO NOT** ground to a gas or hot water pipe. The grounded cold water pipe must have metal to metal connections all the way to electrical ground. If there are any nonmetallic interruptions, such as a meter, pump, plastic, rubber, or other insulating connectors, they **must be** jumped out with no. 4 copper wire and securely clamped to bare metal at both ends.

**IMPORTANT:** For personal safety and proper operation, the dryer **must be** grounded. For proper operation of the microprocessor (computer), an earth (zero) ground **is required**.

**NOTE:** Grounding via metallic electrical conduit (pipe) *is not recommended*.



## G. GAS INFORMATION

It is your responsibility to have **ALL** plumbing connections made by a qualified professional to assure that the gas plumbing installation is adequate and conforms with local and state regulations or codes. In the absence of such codes, **ALL** plumbing connections, materials, and workmanship **must conform** to the applicable requirements of the National Fuel Gas Code ANSI Z223.1-LATEST EDITION or Canadian Standards: CAN/CGA-B149.1-M91(Natural Gas) or CAN/CGA-B149.2-M91(LP Gas).

**IMPORTANT:** Failure to comply with these codes or ordinances, and/or the requirements stipulated in this manual, can result in PERSONAL INJURY and IMPROPER OPERATION of the dryer.

The dryer and its individual shut-off valves **must be** disconnected from the gas supply piping system during any pressure testing of that system at test pressures in excess of 1/2 psig (3.5 kPa). The dryer **must be** isolated from the gas supply piping system by closing its individual manual shut-off valve during any pressure test of the gas supply system at test pressures equal to or less than 1/2 psig (3.5 kPa).

**IMPORTANT:** Failure to isolate or disconnect the dryer from supply as noted can cause irreparable damage to the gas valve and will VOID THE WARRANTY.

**WARNING: FIRE or EXPLOSION COULD RESULT.**

### 1. Gas Supply

The gas dryer installation **must meet** the American National Standard...National Fuel Gas Code ANSI Z223.1-LATEST EDITION, as well as local codes and ordinances and **must be** done by a qualified professional.

**NOTE:** Undersized gas piping will result in ignition problems, slow drying, increased use of energy, and can create a safety hazard.

The dryer **must be** connected to the type of heat/gas indicated on the dryer label affixed behind the right control box door. If this information does not agree with the type of gas available, **DO NOT operate the dryer**. Contact the distributor who sold the dryer or the **ADC** factory.

**IMPORTANT:** Any burner changes or conversions **must be** made by a qualified professional.

The input ratings shown on the dryer data label are for elevations up to 2,000 feet, unless elevation requirements of over 2,000 feet were specified at the time the dryer order was placed with the factory. The adjustment or conversion of dryers in the field for elevations over 2,000 feet are made by changing each burner orifice. If this conversion is necessary, contact the distributor who sold the dryer or contact the **ADC** factory.

2. Technical Gas Data

a. Gas Specifications

<b>TYPE OF GAS</b>		
	NATURAL	LIQUID PROPANE
MANIFOLD PRESSURE*	3.5 inches W.C.	10.5 inches W.C.
INLINE PRESSURE	6.0 to 12.0 inches W.C.	10.5 inches W.C.

\* Measured at gas valve pressure tap when the gas valve is on.

b. Gas Connections:

Inlet connection ----- 1-inch N.P.T.  
 Inlet supply size ----- 1-inch N.P.T. (minimum)  
 Btu/hr input (per dryer) ----- 343,000

1) Natural Gas

Regulation is controlled by the dryer's gas valve's internal regulator. Incoming supply pressure **must be** consistent between a minimum of 6 inches and a maximum of 12 inches water column pressure.

2) Liquid Propane (L.P.) Gas

Dryers made for use with L.P. gas have the gas valve's internal pressure regulator blocked open so that the gas pressure **must be** regulated upstream of the dryer. The pressure measured at each gas valve pressure tap must be a consistent 10.5 inches water column. There is no regulator or regulation provided in an L.P. dryer. The water column pressure **must be** regulated at the source (L.P. tank) or an external regulator **must be** added to each dryer.

		<b>TYPE OF GAS</b>						L.P. Conversion Kit Part Number
Model Number	BTU Per Hour Rating	NATURAL			LIQUID PROPANE			
		Qty.	D.M.S.*	Part Number	Qty.	D.M.S.*	Part Number	
ADG-115D	343,000	3	#8	140837	3	#31	140818	880876

\* D.M.S. (Drill Material Size) equivalents are as follows:

Natural Gas ..... #8 = .1990"  
 Liquid Propane Gas ..... #31 = .1200"

### 3. Piping and Connections

**ALL** components and materials **must conform** to National Fuel or Canadian gas code specifications. It is **Important** that gas pressure regulators meet applicable pressure requirements and that gas meters be rated for the total amount of all the appliance Btu's being supplied.

The dryer is provided with a 1-inch N.P.T. inlet pipe connection extending out the back area of the burner box. The minimum pipe size connection (supply line) to the dryer is 1-inch N.P.T. For ease of servicing, the gas supply line of each dryer **must have** its own shut-off valve.

The size of the main gas supply line (header) will vary depending on the distance this line travels from the gas meter or, in the case of L.P. gas, the supply tank, other gas-operated appliances on the same supply line, etc. Specific information regarding supply line size **should be** determined by the gas supplier.

**NOTE:** Undersized gas supply piping can create a low or inconsistent pressure which will result in erratic operation of the burner ignition system.

Consistent gas pressure is essential at **ALL** gas connections. It is recommended that a 1-inch pipe gas loop be installed in the supply line serving a bank of dryers. An in-line pressure regulator must be installed in the gas supply line (header) if the (natural) gas pressure exceeds 12 inches of water column (W.C.) pressure.

**IMPORTANT:** A water column (W.C.) pressure of 3.5 inches for natural gas and 10.5 inches for L.P. dryers is required at the gas valve pressure tap of each dryer for proper and safe operation.

A 1/8-inch N.P.T. plugged tap, accessible for a test gauge connection, must be installed in the main gas supply line immediately upstream of each dryer.

**IMPORTANT:** Pipe joint compounds that resist the action of natural and L.P. gases **must be** used.

**IMPORTANT:** Test **ALL** connections for leaks by brushing on a soapy water solution (liquid detergent works well).

**WARNING:** **NEVER TEST FOR GAS LEAKS WITH A FLAME!!!**

**ALL** components and materials **must conform** to National Fuel or Canadian gas code specifications. It is important that gas pressure regulators meet applicable pressure requirements, and that gas meters be rated for the total amount of appliance Btu's being supplied.

**IMPORTANT:** The dryer and its individual shut-off valve **must be** disconnected from the gas supply piping system during any pressure testing of that system at test pressures in excess of 1/2 psig (3.5kPa).

**NOTE:** The dryer **must be** isolated from the gas supply piping system by closing its individual manual shut-off valve during any pressure testing of the gas supply piping system at test pressures equal to or less than 1/2 psig (3.5kPa).

TYPICAL NATURAL GAS INSTALLATION

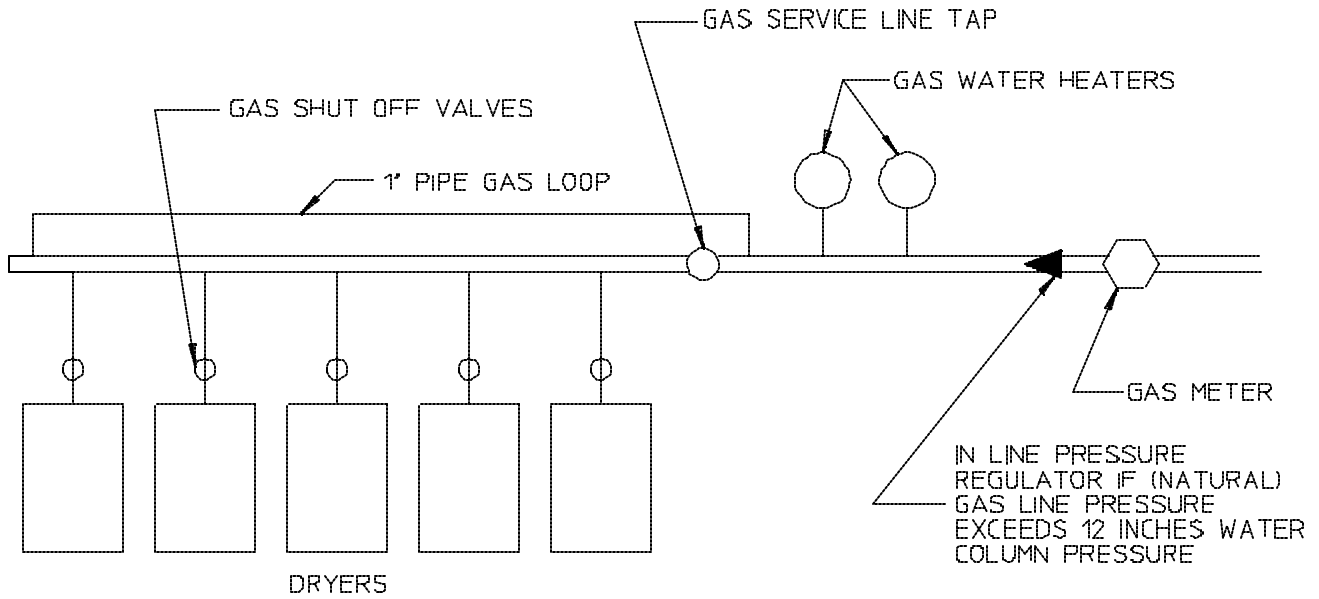

TYPICAL L.P. GAS INSTALLATION

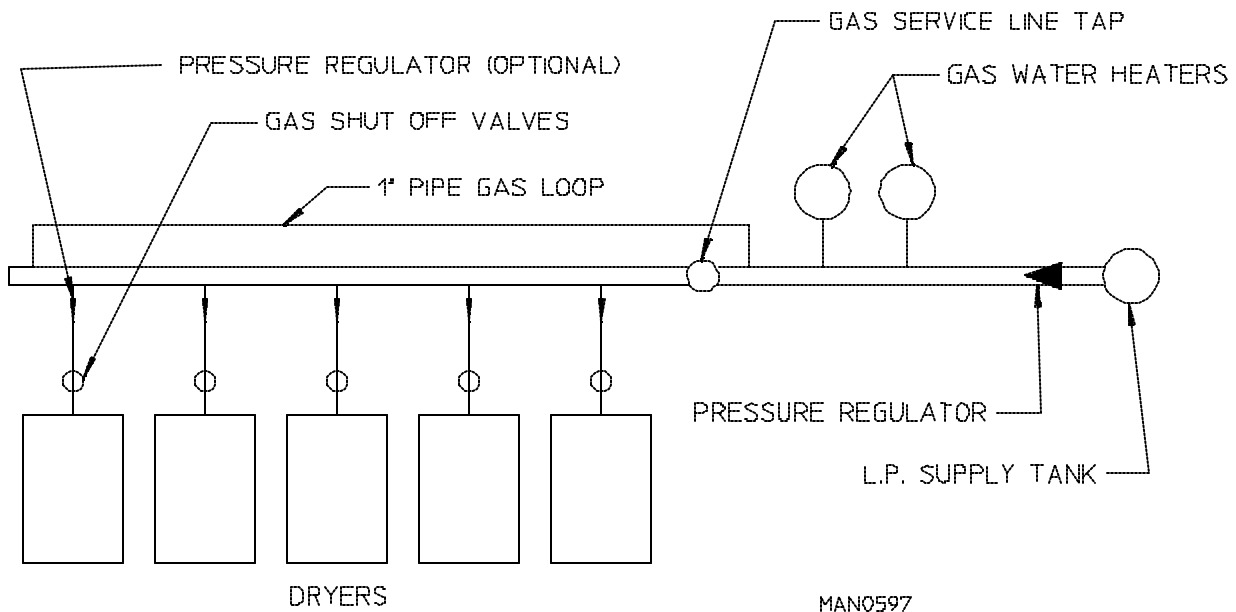

MAN0597

## H. STEAM INFORMATION

It is your responsibility to have **ALL** steam plumbing connections made by a qualified professional to assure that the installation is adequate and conforms with local and state regulations or codes.

**IMPORTANT:** Failure to comply with the requirements stipulated in this manual can result in component failure which will VOID THE WARRANTY.

**NOTE:** The ADS-115 is manufactured with a pneumatic (piston) damper system which requires an external supply of clean, dry, regulated air (80 PSI  $\pm$  10 PSI). Refer to **Steam Damper Air System Connections**, Section H, item 3.

### 1. Steam Coil PH Level

The normal PH level for copper type steam coils **must be** maintained between a value of 8.5 to 9.5. For steel type steam coils the PH level **must be** maintained between a value of 9.5 to 10.5. These limits are set to limit the acid attack of the steam coils.

**IMPORTANT:** Coil failure due to improper PH level will VOID THE WARRANTY.

### 2. Steam Requirements - High Pressure

Inlet ----- 1-1/4" supply line connection -- qty. one (1) at top manifold.

Return ----- 1-1/4" return line connection --- qty. one (1) at bottom manifold.

<b>OPERATING STEAM PRESSURE</b>	
MAXIMUM	125 psig
MINIMUM	100 psig*
HEAT INPUT (Normal Load)	12 Bhp
CONSUMPTION (Approximate)	410 lbs/hr

### 3. Installation Instructions

To insure that an adequate supply of steam is provided, be sure that the steam supply and steam return lines are sized and laid out as stipulated in this manual. Inadequate steam supply and steam return lines are sized and laid out as stipulated in this manual. Inadequate steam supply and steam return lines or improper steam plumbing will result in poor performance and can cause component failure. Clean, dry, regulated steam **must be** provided to the dryer.

**IMPORTANT:** Steam coil failure due to water hammer by wet steam will VOID THE WARRANTY.

- a. The pressure of the condensate in the steam supply will cause water hammer and subsequent heat exchanger (steam coil) failure. The steam supply connection into the main supply line **must be** made within a minimum 12-inch riser. This will prevent any condensate from draining towards the dryer.
- b. The steam supply piping to the dryer **must include** a 12-inch rise along with a drip trap and check valve. This will prevent any condensate from entering the steam coil.
- c. Flexible hoses or couplings **must be** used. The dryer vibrates slightly when it runs and this will cause the steam coil connections to crack if they are hard piped to the supply and return mains.
- d. Shut-off valves for each dryer **should be** installed in the supply, return, and drip trap return lines. This will allow the dryer to be isolated from the supply and return mains if the dryer needs maintenance work.
- e. Install an inverted bucket steam trap and check valve for each unit at least 12 inches below steam coil as close to the coil as possible.
  - 1) A trap with a capacity of 1,200 pounds of condensate per hour at 125 PSI is needed for each unit.
- f. A 3/4-inch vacuum breaker **should be** installed for each unit in the piping. This will prevent the condensing steam from causing a vacuum inside the coil and possibly damaging the coil.
- g. The supply and return lines **should be** insulated. This will save energy and provide for safety of the operator and maintenance personnel.
- h. Water pockets in the supply line, caused by low points, will provide wet steam to the coil possibly causing coil damage. **ALL** horizontal runs of steam supply piping **should be** pitched 1/4-inch for every one (1) foot back towards the steam supply header causing any condensate in the line to drain to the header. Install a bypass trap in any low point to eliminate wet steam.

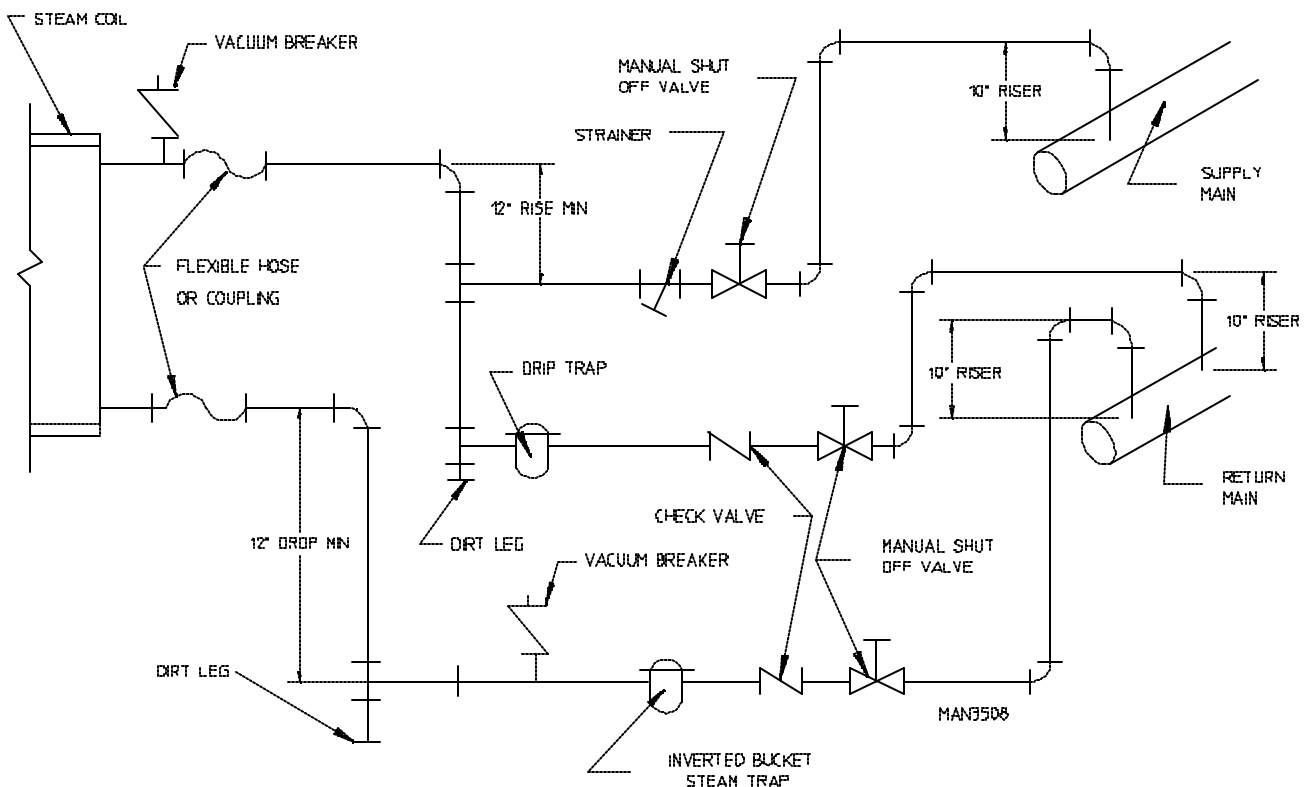

### 3. STEAM DAMPER AIR SYSTEM CONNECTIONS

The ADS-115 is manufactured with a pneumatic (piston) damper system which requires an external supply of compressed air. The air connection is made to the steam damper solenoid valve which is located at the rear inner top area of the dryer just above the electric service relay box.

#### a. Air Requirements

COMPRESSED AIR SUPPLY	AIR PRESSURE
NORMAL	80 psi
MAXIMUM	70 psi
MINIMUM	90 psi

#### b. Air Connection

Air connection to system --- 1/8-inch N.P.T.

c. No air regulation or filtration is provided with the dryer. External regulation and filtration of 80 PSI **must be** provided. It is suggested that a regulator and filter gauge arrangement be added to the compressed air line just before the dryer connection. This is necessary to insure that correct and clean air pressure is achieved.

### 4. Steam Damper System Operation

The ADS-115 steam damper, as shown in the **top illustration on page 36**, allows the coil to stay constantly charged eliminating repeated expansion and contraction. When the damper is opened, the air immediately passes through the already hot coil, providing instant heat to start the drying process. When the damper is closed, ambient air is drawn directly into the basket (tumbler), allowing a rapid cool down.

Diagram 1 -- shows the damper in the heating (open) mode, allowing heat into the basket (tumbler).

Diagram 2 -- shows the damper in the cool down (closed) mode, pulling ambient air directly into the basket (tumbler) without passing through the coils.

<p><b>NOTE:</b> With the dryer off or with no air supply, the damper is in the cool down mode as shown in <b>Diagram 2. (on page 36)</b></p>
--

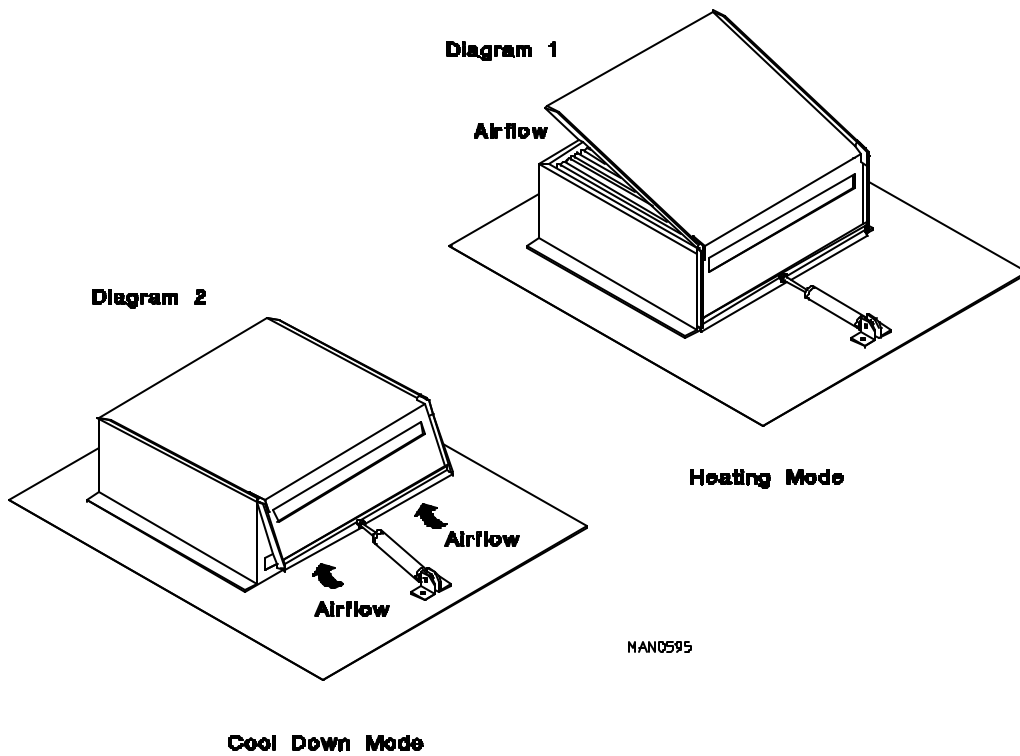

5. Steam Damper Air Piston (Air Control) Operation Adjustment

Although the damper operation was tested and adjusted prior to shipping at 80 PSI, steam damper operation **must be** checked before the dryer is put into operation. Refer to [page 37](#) for instructions to check system damper operation. If damper air adjustment is necessary, locate flow control valve and make necessary adjustments as noted below.

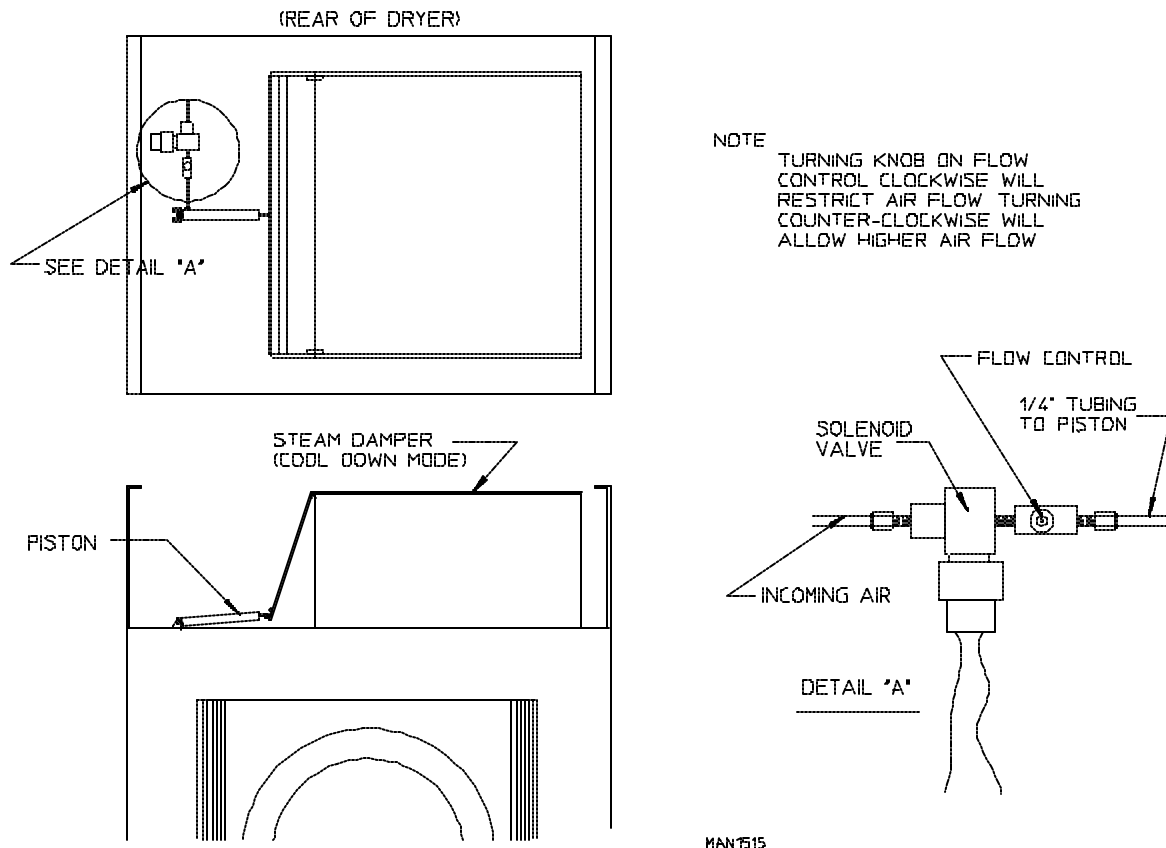

MAN1515



## I. PREPARATION FOR OPERATION AND START-UP

The following items **should be** checked before attempting to operate the dryer:

1. Read **ALL** "CAUTION," "WARNING," and "DIRECTION" labels attached to the dryer.
2. Check incoming supply voltage to be sure that it is the same as indicated on the dryer data label affixed to the back of the dryer at the upper right hand corner. In case of 208 VAC or 230/240 VAC, the supply voltage **must match** the electric service **exactly**.
3. **GAS MODELS** - check to assure that the dryer is connected to the type of heat or gas indicated on the dryer data label.
4. **GAS MODELS** - the sail switch damper assembly was installed and adjusted at the factory prior to shipping. However, each sail switch adjustment **must be** checked to assure that this important safety control is functioning.
5. Check to be sure drive belts between idler pulley and motor pulley have been reconnected.
6. **GAS MODELS** - be sure that **ALL** gas shut-off valves are in the open position.
7. Be sure **ALL** back panels (guards) and electric box covers have been replaced.
8. Check **ALL** service doors to assure that they are closed and secured in place.
9. Be sure lint drawer is securely in place.

**NOTE: LINT DRAWER *MUST BE* ALL THE WAY IN PLACE TO ACTIVATE SAFETY SWITCH OTHERWISE THE DRYER WILL NOT START.**

10. Rotate the basket (tumbler) by hand to be sure it moves freely.
11. Check bolts, nuts, screws, terminals, and fittings for security.
12. STEAM MODELS - check to insure air supply (80 PSI) is on to the dryer.
13. STEAM MODELS - check to insure **ALL** steam shut-off valves are open.
14. STEAM MODELS - check steam damper operation.
15. Check tumbler bearing set screws to insure they are **ALL** tight.

## J. PREOPERATIONAL TEST

**ALL** dryers are thoroughly tested and inspected before leaving the factory. However, a preoperational test **should be** performed before the dryer is publicly used. It is possible that adjustments have changed in transit or due to marginal location (installation) conditions.

1. Turn on electric power to the dryer.
2. Make sure the main door is closed and the lint drawer is securely in place.
3. Microprocessor (computer) system operational test -- to start dryer...
  - a. Display will read "FILL."
  - b. Press the "E" (preprogrammed) cycle key on the touch pad of the keyboard.
  - c. L.E.D. display will quickly read ... "Ld30," "Lc04," and "F180" (unless special programs requested). These codes mean that the dryer is in the timed mode and will operate with heat of 180° F (Fahrenheit) for 30 minutes drying time and have a 4-minute cool down period.
  - d. Dryer will now start and the L.E.D. display will read "Dr30" (dry mode for 30 minutes) and count down in minutes.

**NOTE:** The dryer can be stopped at any time by opening main door or by pressing the "CLEAR/STOP" key. To restart the dryer, press the "ENTER/START" key or preprogrammed cycle key (i.e., "E").

**NOTE:** Pressing touch pad key "A," "B," "C," "D," and "F," will also start the dryer. The six (6) pre-programmed drying cycles ("A" through "F") have been stored in the microprocessor (computer's) memory. Refer to the computer programming manual supplied with dryer for these preprogrammed cycles.

4. Check to insure that the basket (tumbler) starts in the clockwise (CW) direction. Additionally, check the direction of the blower motor impellor (fan) to insure that impellor (blower/fan) rotates in the clockwise (CW) direction as viewed from the front. If it is, the phasing is correct. If the phasing is incorrect, reverse two (2) of the leads at L1, L2, or L3 of the power supply connections made to the dryer.

**IMPORTANT:** Dryer blower motor impellor and fan as viewed from the front **must turn** in the clockwise (CW) direction, otherwise dryer efficiency will drastically be reduced and premature component failure can result.

## 5. HEAT CIRCUIT OPERATIONAL TEST

### a. Gas Models

- 1) When the dryer is first started (during initial start-up), the burner has a tendency not to ignite on the first attempt. This is because the gas supply piping is filled with air, so it may take a few minutes for this air to be purged from the lines.
- 2) The dryer is equipped with a direct spark ignition (DSI) system which has internal diagnostics. If ignition is not established after the first attempt, the heat circuit DSI module will lock out until it is manually reset. To reset the DSI system, open and close main door and restart dryer (press the "ENTER/START" key).

**NOTE:** During the purging period, check to be sure that **ALL** gas shut-off valves are open.

- 3) Once ignition is established, a gas pressure test **should be** taken at the gas valve pressure tap of each dryer to assure that the water column pressure is correct and consistent.

**NOTE:** Water column (W.C.) pressure requirements (measured at the gas valve pressure tap)...

NATURAL GAS --- 3.5 INCHES W.C.  
L.P. GAS ----- 10.5 INCHES W.C.

**IMPORTANT:** There is no regulator provided in an L.P. dryer. The water column pressure **must be** regulated at the source (L.P. tank) or an external regulator **must be** added to each dryer.

### b. Electric Models

- 1) Check the oven contactors to insure that the electric oven is cycling properly.

### c. Steam Models

- 1) Check to insure that steam damper is functioning properly.
  - a) The steam damper **should not** "slam" (open/closed) when it reaches the end of (piston) travel. Additionally, the steam damper **should not** bind or stop during travel. If either of these conditions occur, the flow control **must be** adjusted. Refer to the bottom illustration on **page 36** for air adjustment instructions.

6. Make a complete operational check of **ALL** safety-related circuits (i.e., lint drawer switch, and sail switch on gas models).

**NOTE:** To check for proper sail switch operation, open the main door and while holding main door switch plunger in, start dryer. Dryer should start but heat circuit *should not* be activated (on). If heat (burner) does activate, shut dryer off and make necessary adjustments.

7. A reversing basket (tumbler) dryer **should never** be operated with less than a 60 lb. load (dry weight). The size of the load will affect the coast-down and dwell (stop) times. The basket (tumbler) must come to a complete stop before starting in opposite direction.

a. Microprocessor (computer) Dryer Models

- 1) Spin and stop times *are not adjustable* in the Automatic Mode and have been preprogrammed into the microprocessor controller (computer) for 120-second spin time and a 5-second dwell (stop) time.
- 2) Spin and stop times *are adjustable* in the Manual (timed) Mode.

b. Dual Timer Dryer Models

- 1) Spin and stop times *are adjustable* at the reversing timer.

**IMPORTANT:** The dryer basket (tumbler) is treated with a protective coating. **ADC** suggests tumbling old clothes or material in the basket (tumbler), using a mild detergent to remove the protective coating.

8. Each dryer **should be** operated through one complete cycle to assure that no further adjustments are necessary and that **ALL** components are functioning properly.

9. Make a complete operational check of **ALL** operating controls.

a. Microprocessor controller (computer) programs and selections...

- 1) Each microprocessor controller (computer) has been preprogrammed by the factory with the most commonly used parameter (program) selections. If computer program changes are required, refer to the computer programming manual which was shipped with the dryer.

b. Dual timer dryers check...

- 1) Heating Timer
- 2) Cool Down Timer
- 3) Temperature Selection Switch

# SECTION IV

## SERVICE AND PARTS INFORMATION

### A. SERVICE

1. Service **must be** performed by a qualified trained technician, service agency, or gas supplier. If service is required, contact the distributor from whom the **ADC** equipment was purchased. If the distributor cannot be contacted or is unknown, contact the **ADC** Service Department for a distributor in your area.

**NOTE:** When contacting the **ADC** Service Department, be sure to give them the correct **model number** and **serial number** so that your inquiry is handled in an expeditious manner.

### B. PARTS

1. Replacement parts **should be** purchased from the distributor from whom the **ADC** equipment was purchased. If the distributor **cannot** be contacted or is unknown, contact the **ADC** Parts Department for a distributor in your area. Parts may also be purchased directly from the factory by calling the **ADC** Parts Department at (508) 678-9000 or you may FAX in your order at (508) 678-9447.

**NOTE:** When ordering replacement parts from the **ADC** dealer or the **ADC** factory be sure to give them the correct **model number** and **serial number** so that your parts order can be processed in an expeditious manner.

# SECTION V

## WARRANTY INFORMATION

### A. RETURNING WARRANTY CARDS

1. Before any dryer leaves the **ADC** factory test area, a warranty card (**ADC** Part No. 112254) is placed on the back side of the main door glass. These warranty cards are intended to serve the customer where we record the individual installation date and warranty information to better serve you should you file a warranty claim.
  - a. If a warranty card (**ADC** Part No. 112254) did not come with your dryer, contact the **ADC** Warranty Department or **ADC** Service Department at (508) 678-9000.

**IMPORTANT:** A separate warranty card *must be* completed and returned for each individual dryer.

**NOTE:** Be sure to include the installation date when returning the warranty cards.

### B. WARRANTY

For a copy of the **ADC** commercial warranty covering your particular dryers, contact the **ADC** distributor from whom you purchased the equipment and request dryer warranty form **ADC** Part No. 450199. If the distributor **cannot** be contacted or is unknown, warranty information can be obtained from the factory by contacting the **ADC** Warranty Department at (508) 678-9000.

**NOTE:** Whenever contacting the **ADC** factory for warranty or warranty information, be sure to have the dryer's **model number** and **serial number** available so that your inquiry can be handled in an expeditious manner.

### C. RETURNING WARRANTY PARTS

**ALL** dryer or parts warranty claims or inquiries **should be** addressed to the **ADC** Warranty Parts Department. To expedite processing, the following procedures **must be** followed:

1. No parts are to be returned to **ADC** without prior written authorization ("Return Material Authorization") from the factory.

**NOTE:** An R.M.A. ("Return Material Authorization") is valid for only sixty (60) days from date of issue.

- a. The R.M.A. issued by the factory, as well as any other correspondence pertaining to the returned parts, **must be** included inside the package with the failed merchandise.

2. Each part **must be** tagged with the following information:
  - a. **Model number** and **serial number** of the dryer from which part was removed.
  - b. Nature of failure (be specific).
  - c. Date of dryer installation.
  - d. Date of part failure.
  - e. Specify whether the parts being returned is for a replacement, a credit, or a refund.

**NOTE:** If a part is marked for a credit or a refund, the invoice number covering the purchase of the replacement part **must be** provided.

**NOTE:** Warranty tags (ADC Part No. 450064) are available at "no charge" from ADC upon request.

3. The company returning the parts must clearly note the complete company name and address on the outside of the package.
4. **ALL** returns **must be** properly packaged to insure that they are not damaged in transit. *Damage claims are the responsibility of the shipper.*

**IMPORTANT:** **NO** replacements, credits or refunds **will be** issued for merchandise damaged in transit.

5. **ALL** returns **should be** shipped to the ADC factory in such a manner that they are insured and a proof of delivery can be obtained by the sender.
6. **Shipping charges are not the responsibility of ADC. ALL returns should be "prepaid" to the factory. Any "C.O.D." or "COLLECT" returns will not be accepted.**

**IMPORTANT:** **NO** replacements, credits, or refunds will be issued if the claim **cannot** be processed due to insufficient information. The party filing the claim will be notified in writing, either by "FAX" or "CERTIFIED MAIL - Return Receipt Requested", as to the information necessary to process claim. If a reply is not received by the ADC Warranty Department within thirty (30) days from the FAX or letter date, then no replacement, credit, or refund will be issued, and the merchandise **will be discarded**.

# SECTION VI

## ROUTINE MAINTENANCE

### A. CLEANING

A program or schedule **should be** established for periodic inspection, cleaning, and removal of lint from various areas of the dryer, as well as throughout the duct work system. The frequency of cleaning can best be determined from experience at each location. Maximum operating efficiency is dependent upon proper air circulation. The accumulation of lint can restrict this air flow. If the guidelines in this section are met, an ADC dryer will provide many years of efficient, trouble-free, and - most importantly - safe operation.

**WARNING: LINT FROM MOST FABRICS IS HIGHLY COMBUSTIBLE. THE ACCUMULATION OF LINT CAN CREATE A POTENTIAL FIRE HAZARD.**

**WARNING: KEEP DRYER AREA CLEAR AND FREE FROM COMBUSTIBLE MATERIALS, GASOLINE, and OTHER FLAMMABLE VAPORS and LIQUIDS.**

**NOTE:** Suggested time intervals shown are for average usage which is considered six (6) to eight (8) operational (running) hours per day.

**Clean the lint drawer or screen every third or fourth load.**

**NOTE:** Frequency can best be determined at each location.

### SUGGESTED CLEANING SCHEDULE

#### *DAILY (beginning of each work shift)*

Clean lint from screen.

Inspect lint screen and replace if torn.

#### *WEEKLY*

Clean lint accumulation from lint chamber, thermostat, and microprocessor temperature sensor (sensor bracket) area.

**WARNING: TO AVOID THE HAZARD OF ELECTRICAL SHOCK, DISCONTINUE ELECTRICAL SUPPLY TO THE DRYER.**



## ***STEAM DRYERS***

Clean the steam coil fins. We suggest using compressed air and a vacuum cleaner with brush attachment.

**WARNING:** A When cleaning steam coil fins, be careful not to bend the fins. If fins are bent, straighten by using a fin comb which is available from local air-conditioning supply houses.

### ***90 DAYS***

Remove lint from around basket (tumbler), drive motors, and surrounding areas.

Remove lint from gas valve burner area with a dusting brush or vacuum cleaner attachment.

Clean any lint that may have collected in and around the blower motor casing openings.

**IMPORTANT:** TO PREVENT DAMAGE, AVOID CLEANING OR TOUCHING IGNITOR and FLAME-PROBE ASSEMBLY

Remove lint accumulation from inside control box and at the rear area behind control box.

### ***6 MONTHS***

Inspect and remove lint accumulation in customer furnished exhaust duct work system and from dryers internal exhaust ducting.

**WARNING: THE ACCUMULATION OF LINT IN THE EXHAUST DUCT WORK CAN CREATE A POTENTIAL FIRE HAZARD.**

**WARNING: *DO NOT* OBSTRUCT THE FLOW OF COMBUSTION and VENTILATION AIR. CHECK CUSTOMER FURNISHED BACK DRAFTED DAMPERS IN EXHAUST DUCT WORK. INSPECT and REMOVE ANY LINT ACCUMULATION WHICH CAN CAUSE DAMPER TO BIND OR STICK.**

**NOTE:** A back draft damper that is sticking partially closed can result in slow drying and shutdown of the heat circuit safety switches or thermostats.

**NOTE:** When cleaning dryer cabinets, avoid using harsh abrasives. A product intended for the cleaning of appliances is recommended.

## B. ADJUSTMENTS

### *7 Days After Installation and Every 6 Months Thereafter*

Inspect bolts, nuts, screws (bearing set screws), nonpermanent gas connections (unions, shut-off valves, orifices, and grounding connections). Motor and drive belts **should be** examined. Cracked or seriously frayed belts **should be** replaced. Tighten loose V-belts when necessary. Complete operational check of controls and valves. Complete operational check of **ALL** safety devices (door switch, lint drawer switch, sail switch, burner and hi-limit thermostats).

## C. LUBRICATION

Impellor (fan/blower) shaft bearings should be lubricated every (3) months.

The motor bearings, idler bearings, and tumbler bearings are permanently lubricated.  
**NO LUBRICATION IS NECESSARY.**

# SECTION VII

## TROUBLESHOOTING

**IMPORTANT:** YOU MUST DISCONNECT and LOCKOUT THE ELECTRIC SUPPLY and THE GAS SUPPLY or THE STEAM SUPPLY BEFORE ANY COVERS or GUARDS ARE REMOVED FROM THE MACHINE TO ALLOW ACCESS FOR CLEANING, ADJUSTING, INSTALLATION, or TESTING OF ANY EQUIPMENT per OSHA (Occupational Safety and Health Administration) STANDARDS.

The information provided will help isolate the most probable components associated with the difficulty described. The experienced technician realizes, however, that a loose connection or broken or shorted wire may be at fault where electrical components are concerned ... and not necessarily the suspected component itself.

Electrical parts **should always be** checked for failure before being returned to the factory.

**IMPORTANT:** When replacing blown fuses, the replacement *must be* of the exact rating as the fuse being replaced. The information provided *should not be* misconstrued as a hand-book for use by an untrained person making repairs.

**WARNING:** ALL SERVICE and TROUBLESHOOTING **SHOULD BE** PERFORMED BY A QUALIFIED PROFESSIONAL OR SERVICE AGENCY.

**WARNING:** WHILE MAKING REPAIRS, OBSERVE ALL SAFETY PRECAUTIONS DISPLAYED ON THE DRYER or SPECIFIED IN THIS MANUAL.

### **A. No L.E.D. (light emitting diode) display...**

1. Service panel fuse blown or tripped breaker.
2. Blown control circuit L1 or L2 fuse.
3. Failed microprocessor controller (computer).

### **B. Drive motor not operating (does not start)...**

1. Failed drive motor contactor (relay).
2. Failed arc suppressor (A.S.) board.
3. Failed drive motor.
4. Failed microprocessor controller (computer).

**C. Drive motor (reversing) operates in one direction only...stops and restarts in same direction...**

1. Failed drive motor contactor (relay).
2. Failed arc suppressor (A.S.) board.
3. Failed microprocessor controller (computer).

**D. Drive motor operates okay for a few minutes, and then stops and will not restart...**

1. Motor is overheating and tripping out on internal overload protector ...
  - a. Motor air vents clogged with lint.
  - b. Low voltage to the motor.
  - c. Failed motor.
  - d. Basket (tumbler) is binding...check for obstruction.
  - e. Failed idler bearings or tumbler bearings.

**E. Blower motor not operating (does not start)...**

1. Failed blower motor contactor (relay).
3. Failed arc suppressor (A.S.) board.
4. Failed motor.
5. Failed microprocessor controller (computer).

**F. Blower motor operates okay for a few minutes, then stops and will not restart...**

1. Motor is overheating and tripping out on internal overload protector ...
  - a. Motor air vents clogged with lint.
  - b. Low voltage to the motor.
  - c. Failed motor.
  - d. Failed (out of balance) impellor (fan/blower).

**G. Both drive motor and blower motor not operating (do not start)...microprocessor controller (computer) motor indicator dots are on...**

1. Failed arc suppressor (A.S.) board.
2. Failed microprocessor controller (computer).

**H. Both drive motor and blower motor run a few minutes and then stop...microprocessor controller (computer) display continues to read time or percent of extraction and all indicator dots are off...**

1. Fault in main door switch circuit ...
  - a. Failed main door switch.
  - b. Main door switch out of adjustment.
  - c. Loose connection in door switch circuit.

2. Fault in lint drawer switch circuit...
  - a. Lint drawer switch out of proper adjustment.
  - b. Loose connection in the lint drawer switch circuit.

**I. Microprocessor (computer) display reads "dSFL"...**

1. Fault in microprocessor heat sensing circuit ...
  - a. Blown 1/8-amp ("dSFL") fuse on microprocessor controller (computer).
  - b. Failed microprocessor temperature sensor.
  - c. Failed microprocessor controller (computer).
  - d. Broken wire or connection somewhere between the microprocessor controller (computer) and the microprocessor temperature sensor.

**J. Microprocessor controller (computer) display reads "door"...**

1. Fault (open circuit) in main door or lint drawer switch circuit ...
  - a. Lint drawer is not closed all the way.
  - b. Lint drawer switch out of proper adjustment.
  - c. Failed lint drawer switch.
  - d. Failed main door switch.
  - e. Broken connection or wire in main door or lint drawer circuit.
  - f. Failed 24 VAC Transformer.

**K. Microprocessor controller (computer) will not accept any keyboard entries, i.e., L.E.D. display reads "FILL" and when keyboard entries are selected, the L.E.D. display continues to read "FILL"...**

1. Failed keyboard label (touchpad) assembly.
2. Failed microprocessor controller (computer).

**L. Microprocessor controller will only accept certain keyboard entries...**

1. Failed keyboard label (touchpad) assembly.
2. Failed microprocessor controller (computer).

**M. Microprocessor controller (computer) locks up and L.E.D. (light emitting diode) display reads erroneous messages or only partial segments...**

1. Transient power voltage (spikes)...disconnect power to dryer, wait one (1) minute, and reestablish power to dryer. If problem is still evident ...
  - a. Failed microprocessor controller (computer).
  - b. Failed keyboard label (touchpad) assembly.

**N. Dryer stops during a cycle and L.E.D. (light emitting diode) display returns to "FILL"...**

1. Fault in microprocessor heat sensor circuit ...
  - a. Loose connection in wires between temperature sensor and microprocessor controller (computer).
2. Loose connection somewhere in main power circuit to microprocessor controller (computer).

**O. Gas heating unit is not operating (no heat)...no spark at burner area when dryer is first started, and heat indicator dot is on...**

1. Fault in sail switch circuit ...
  - a. Sail switch is out of adjustment or has failed.
  - b. Sail switch damper is not closing or is fluttering ...
    - 1) Lint drawer or screen is dirty.
    - 2) Restriction in exhaust.
2. Fault in burner hi-limit circuit or thermostat.
3. Fault in lint chamber sensor bracket hi-heat protector thermostat.
4. Failed Direct Spark Ignition (DSI) module (burner control).
5. Failed DSI ignitor or flame-probe assembly.
6. Failed microprocessor controller (computer).

**P. No heat (for GAS MODEL ONLY)...ignitor sparks, burner goes on and off right away...**

1. Direct Spark Ignition (DSI) ignitor or flame-probe out of adjustment...reposition closer to the flame area.
2. Sail switch is fluttering ...
  - a. Lint screen dirty.
  - b. Restriction in exhaust duct work.
3. Insufficient make-up air.
4. Failed DSI ignitor or flame-probe assembly.
5. Failed DSI module (burner control).
6. Failed gas valve.

**Q. No heat (for STEAM MODELS ONLY)...**

1. Fault in lint chamber sensor bracket hi-heat (limit) protector thermostat.
2. Failed microprocessor controller (computer).
3. No (external) compressed air to steam damper (80 PSI required).
4. Failed steam damper 24 VAC pneumatic solenoid switch.
5. Failed steam damper piston.
6. Steam damper stuck closed.
7. Air flow control valve restricting incoming compressed air.

**R. No heat (for ELECTRIC MODELS ONLY)...**

1. Fault in sail switch circuit...
  - a. sail switch out of adjustment or faulty (failed).
  - b. sail switch is not closing or fluttering...
    - 1) Check impellor (fan/blower) motor and rotation direction.
    - 2) Restriction in the location exhaust system.
2. Failed oven hi-limit.
3. Failed lint compartment 225° safety thermostat.
4. Failed oven contactor (relay).
5. Failed microprocessor controller (computer).

## **S. Dryer operates but is taking too long to dry...**

1. Exhaust duct work run too long or is undersized...back pressure **cannot** exceed 0.3 inches Water Column (W.C.).
2. Restriction in exhaust ...
  - a. Customer furnished exhaust back draft damper is sticking partially closed.
  - b. Restriction in duct work...check duct work from dryer all the way to the outdoors.
3. Low and/or inconsistent gas pressure (*for GAS MODELS ONLY*).
4. Insufficient make-up air.
5. Poor air or gas mixture at burner...yellow or poor flame pattern; adjust gas burner air adjustment shutters (*for GAS MODELS ONLY*).
6. Lint screen not being cleaned on a regular basis or often enough.
7. Extractors (washers) not performing properly.
8. Sail switch is fluttering...restriction in exhaust (*for GAS MODELS ONLY*).
9. Failed microprocessor controller (computer)...temperature calibration is inaccurate.
10. Failed microprocessor temperature sensor calibration is inaccurate.
11. Failed burner hi-limit (*for GAS MODELS ONLY*).
12. Failed lint chamber hi-heat protector thermostat.
13. Steam damper system not functioning properly (*for STEAM MODELS ONLY*)...
  - a. Steam damper sticking closed.
  - b. Leak in the pneumatic system.
  - c. Flow control incorrectly set.

## **T. Condensation on main door glass...**

1. Too long, undersized, or improperly installed duct work.
2. Dryer connected to common exhaust duct with another dryer and no back draft damper was installed in customer furnished duct work.
3. Customer furnished back draft damper in duct work is sticking in partially closed position.



#### **U. Dryer or scraping noise at basket (tumbler) area...**

1. Check for object caught in basket (tumbler) or wrapper area.
2. Basket (tumbler) is out of proper alignment ...
  - a. Check both vertical and lateral alignment.
  - b. Check gap between front panel and basket (tumbler) front...set screws may have come loose, and basket (tumbler) walked forward or backwards.
3. Loose basket (tumbler) tie rod.
4. Failed basket (tumbler) support.

#### **V. Excessive noise or vibration...**

1. Dryer not leveled properly.
2. Impellor (fan/blower) out of balance ...
  - a. Excessive lint build up on impellor (fan/blower).
  - b. Failed impellor (fan/blower).
3. Loose basket (tumbler) tie rod.
4. Basket (tumbler) out of adjustment, or adjustment bolts (hardware) are loose.
5. Failed basket (tumbler) support.
6. Loose motor mount.
7. Failed idler or tumbler bearings.
8. V-belts either too tight or too loose.

# SECTION VII

## PROCEDURE FOR FUNCTIONAL CHECK OF REPLACEMENT COMPONENTS

### 1. Microprocessor (computer) Board

- a. Upon completing installation of the replacement microprocessor (computer) board, reestablish power to the dryer.
- b. Start the drying cycle.
- c. Verify that the motors and the heat indicator dots, in the microprocessor (computer) L.E.D. (light emitting diode) display are on. (Refer to the illustration below.)

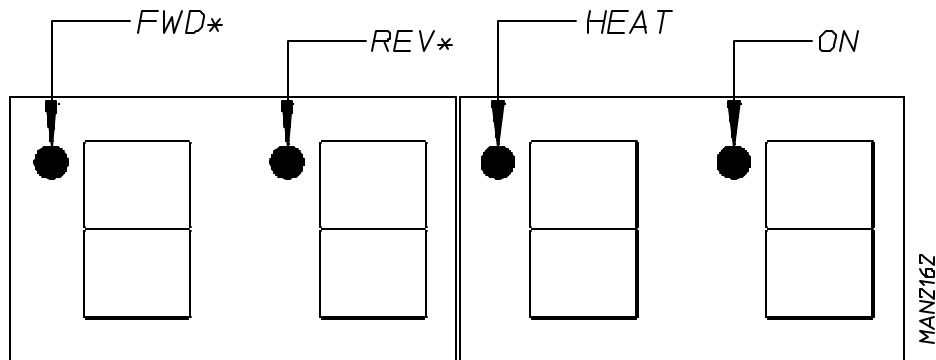

\*OPL (NON-COIN) REVERSING MODELS ONLY

- d. Verify that motors, heat, and door indicator lights on the back side of the microprocessor (computer) board are lit. (Refer to the illustration below.)

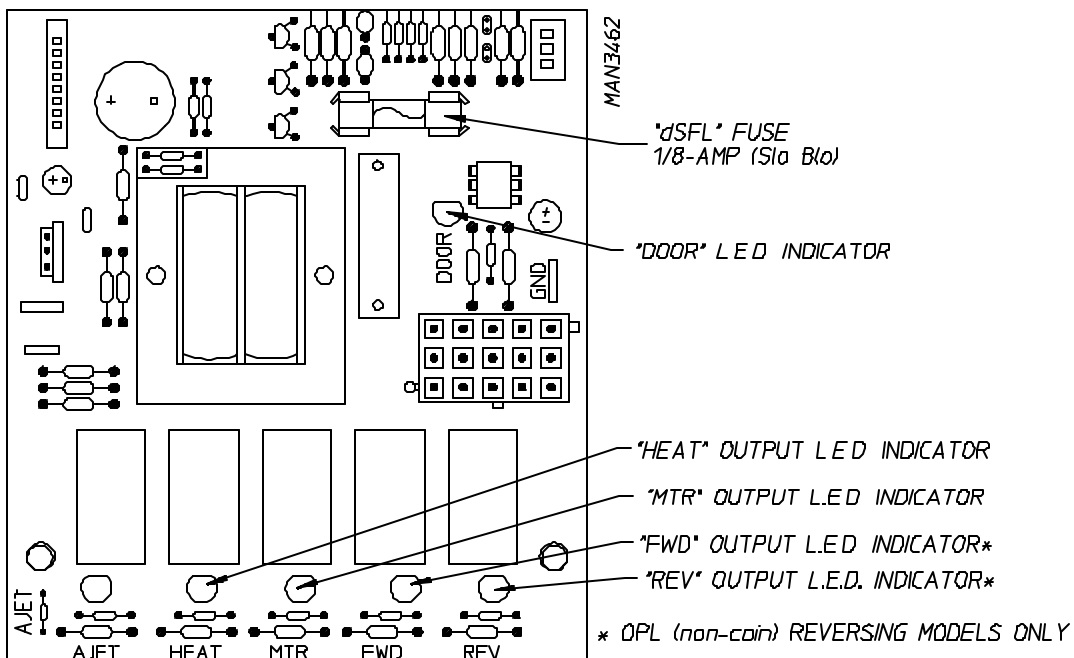

- e. Open main door. The dryer **must stop** and **ALL** output indicator lights on the back side of the microprocessor (computer) board **must go out**.
- f. Try to restart the dryer with the main door open.
- g. The microprocessor (computer) board's L.E.D. display **must read "DOOR."**
- h. Close the main door and restart the dryer.
- i. Functional check of microprocessor (computer) board is complete.

## 2. Direct Spark Ignition (DSI) System

- a. Upon completing installation of the replacement Direct Spark Ignition (DSI) module, reestablish power to the dryer.
- b. Start the drying cycle.
- c. The ignition (DSI) module's L.E.D. indicator will light "red" for up to approximately 1.5 seconds (pre-purge time).
- d. The module's indicator light will then turn "green." The gas valve will be energized and the ignitor probe will spark for approximately 8 seconds. The burner flame **should now be** established.
- e. With the burner flame on, remove the flame sensor wire from the FS terminal of the DSI module.
- f. The burner flame **must shut off** and the ignition module **must lock out** with the DSI module's indicator light "red."
- g. Stop the drying cycle, with the flame sensor wire still removed, restart the drying cycle.
- h. The ignition module **must proceed** through the pre-purge, with the indicator light "red," the ignition trial time of approximately 8 seconds, with the indicator light "green," and then proceed to lock out with the indicator light "red."
- i. Functional check of the Direct Spark Ignition (DSI) Module is complete.

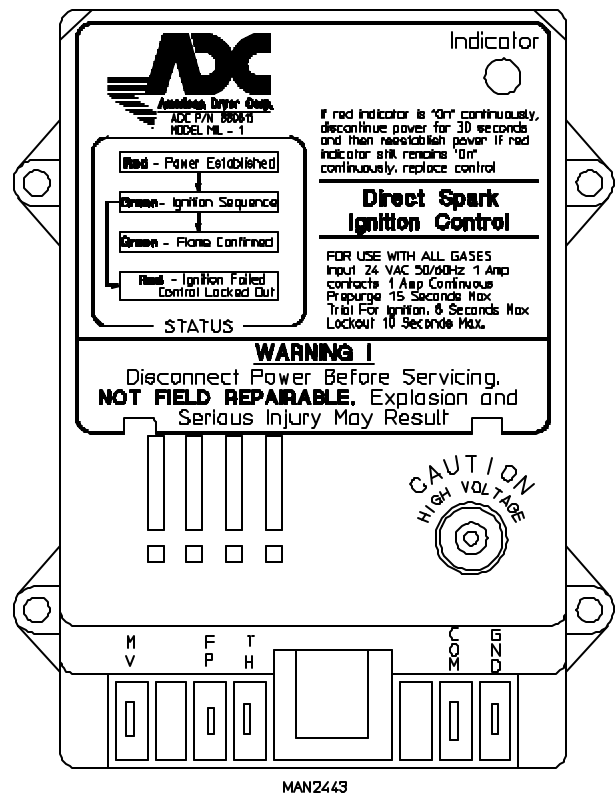

**ADC 112133**    **1-** 08/25/93-10    **2\*** 02/15/94-100    **3\*** 11/15/94-100  
**4\*** 03/24/95-100    **5\*** 12/21/95-100    **6\*** 06/10/96-100  
**7\*** 02/11/97-100    **8\*** 10/23/97-50    **9\*** 02/26/98-50  
**10\*** 06/23/98-50    **11-** 08/17/98-100    **12\*** 05/11/99-35  
**13** 06/30/99-100

