

AD-310

(with Tilting Options)

Installation/Operator's Manual

WARNING: For your safety the information in this manual must be followed to minimize the risk of fire or explosion or to prevent property damage, personal injury or death.

Do not store or use gasoline or other flammable vapor and liquids in the vicinity of this or any other appliance.

WHAT DO YOU DO IF YOU SMELL GAS

- * Do not try to light any appliance.
- * Do not touch any electrical switch; do not use any phone in your building.
- * Clear the room, building or area of all occupants.
- * Immediately call your gas supplier from a neighbor's phone. Follow the gas supplier's instructions.
- * If you cannot reach your gas supplier, call the fire department.

Installation and service must be performed by a qualified installer, service agency or the gas supplier.



For replacement parts, contact the distributor from which the dryer was purchased or

American Dryer Corporation

88 Currant Road

Fall River MA 02720-4781

Telephone: (508) 678-9000 / Fax: (508) 678-9447

E-mail: service@amdry.com

Retain This Manual In A Safe Place For Future Reference

American Dryer Corporation products embody advanced concepts in engineering, design, and safety. If this product is properly maintained, it will provide many years of safe, efficient, and trouble-free operation.

ONLY properly licensed technicians should service this equipment.

OBSERVE ALL SAFETY PRECAUTIONS displayed on the equipment or specified in the installation/operator's manual included with the dryer.

WARNING: UNDER NO CIRCUMSTANCES should the door switch or the heat circuit devices ever be disabled.

WARNING: The dryer *must never* be operated with any of the back guards, outer tops, or service panels removed. PERSONAL INJURY or FIRE COULD RESULT.

We have tried to make this manual as complete as possible and hope you will find it useful. **ADC** reserves the right to make changes from time to time, without notice or obligation, in prices, specifications, colors, and material, and to change or discontinue models.

Important

For your convenience, log the following information:

DATE OF PURCHASE _____ MODEL NO. **AD-310 TILTING**

DISTRIBUTORS NAME _____

Serial Number(s) _____

Replacement parts can be obtained from your distributor or the **ADC** factory. When ordering replacement parts from the factory, you can FAX your order to **ADC** at (508) 678-9447 or telephone your orders directly to the **ADC** Parts Department at (508) 678-9000. Please specify the dryer **model number** and **serial number** in addition to the **description** and **part number**, so that your order is processed accurately and promptly.

The illustrations on the following pages may not depict your particular dryer exactly. The illustrations are a composite of the various dryer models. Be sure to check the descriptions of the parts thoroughly before ordering.

“IMPORTANT NOTE TO PURCHASER”

Information must be obtained from your local gas supplier on the instructions to be followed if the user smells gas. These instructions must be posted in a prominent location near the dryer.

IMPORTANT

YOU MUST DISCONNECT and LOCKOUT THE ELECTRIC SUPPLY and THE GAS SUPPLY or THE STEAM SUPPLY BEFORE ANY COVERS or GUARDS ARE REMOVED FROM THE MACHINE TO ALLOW ACCESS FOR CLEANING, ADJUSTING, INSTALLATION, or TESTING OF ANY EQUIPMENT per OSHA (Occupational Safety and Health Administration) STANDARDS.

CAUTION

LABEL ALL WIRES PRIOR TO DISCONNECTION WHEN SERVICING CONTROLS. WIRING ERRORS CAN CAUSE IMPROPER AND DANGEROUS OPERATION.

VERIFY PROPER OPERATION AFTER SERVICING.

CAUTION

DRYER(S) SHOULD NEVER BE LEFT UNATTENDED WHILE IN OPERATION.

WARNING

CHILDREN SHOULD NOT BE ALLOWED TO PLAY ON OR NEAR THE DRYER(S).

CHILDREN SHOULD BE SUPERVISED IF NEAR DRYER(S) IN OPERATION.

WARNING

The dryer must never be operated with any of the back guards, outer tops, or service panels removed. PERSONAL INJURY or FIRE COULD RESULT.

FOR YOUR SAFETY

DO NOT STORE OR USE GASOLINE OR OTHER FLAMMABLE VAPOR AND LIQUIDS IN THE VICINITY OF THIS OR ANY OTHER APPLIANCE.

DO NOT DRY MOP HEADS IN THE DRYER.

DO NOT USE DRYER IN THE PRESENCE OF DRY CLEANING FUMES.

IMPORTANT

PLEASE OBSERVE ALL SAFETY PRECAUTIONS displayed on the equipment and/or specified in the installation/operator's manual included with the dryer.

Dryer(s) **must not** be installed or stored in an area where it will be exposed to water and/or weather.

The wiring diagram for the dryer is located in the front electrical control box area.

Table of Contents

SECTION I

IMPORTANT INFORMATION

A. RECEIVING and HANDLING	3
B. SAFETY PRECAUTIONS	4

SECTION II

SPECIFICATIONS/DIMENSIONS and COMPONENT IDENTIFICATION

A. SPECIFICATIONS (Gas and Steam Models)	6
ADS-310 Tilting 1-Door/1-Way Tilt STEAM MODEL	7
ADG-310 Tilting 1-Door/1-Way Tilt GAS MODEL	7
ADS-310 Tilting 1-Door/2-Way Tilt STEAM MODEL	8
ADG-310 Tilting 1-Door/2-Way Tilt GAS MODEL	8
ADS-310 Tilting 2-Door/1-Way Tilt STEAM MODEL	9
ADG-310 Tilting 2-Door/1-Way Tilt GAS MODEL	9

SECTION III

INSTALLATION PROCEDURES

A. REASSEMBLY OF DRYER	10
1. Reassembly Instructions (<i>for Gas Dryer</i>) Shipped In <i>Two Pieces</i> ADG-310 1-Door/Forward Tilt	11
2. Reassembly Instructions (<i>for Gas Dryer</i>) Shipped In <i>Two Pieces</i> ADG-310 1-Door/2-Way Tilt	14
3. Reassembly Instructions (<i>for Gas Dryer</i>) Shipped In <i>Two Pieces</i> ADG-310 2-Door/Rear Tilt (Pass Thru)	17
4. Reassembly Instructions (<i>for Steam Dryer</i>) Shipped In <i>Two Pieces</i> ADS-310 1-Door/Forward Tilt	20
5. Reassembly Instructions (<i>for Steam Dryer</i>) Shipped In <i>Two Pieces</i> ADS-310 1-Door/2-Way Tilt	23
6. Reassembly Instructions (<i>for Steam Dryer</i>) Shipped In <i>Two Pieces</i> ADS-310 2-Door/Rear Tilt (Pass Thru)	26
B. LOCATION REQUIREMENTS	29
C. FRESH AIR SUPPLY REQUIREMENTS	30
D. EXHAUST REQUIREMENTS	31
E. COMPRESSED AIR SUPPLY SYSTEM	38
F. ELECTRICAL INFORMATION	40
G. GAS INFORMATION	43
H. STEAM INFORMATION	47
I. WATER SUPPLY CONNECTION FOR OPTIONAL SPRINKLER SYSTEM	51
J. PREOPERATIONAL TESTS	52
K. PREPARATION FOR OPERATION/START-UP	54
L. SHUT DOWN INSTRUCTIONS	55

SECTION IV	
SERVICE / PARTS INFORMATION	
A. SERVICE	56
B. PARTS	56
SECTION V	
WARRANTY INFORMATION	
A. RETURNING WARRANTY CARD(S)	57
B. WARRANTY	57
C. RETURNING WARRANTY PART(S)	57
SECTION VI	
ROUTINE MAINTENANCE	
A. CLEANING	59
B. ADJUSTMENTS	61
SECTION VII	
COMPONENT SYSTEM DESCRIPTIONS	
A. TUMBLER DRIVE SYSTEM	62
B. TUMBLER	63
C. AIR BLOWER DRIVE SYSTEM	63
D. SAFETY DEVICES	63
E. STEAM DAMPER ACTUATOR SYSTEM	65
SECTION VIII	
TROUBLESHOOTING	
	66
SECTION IX	
PROCEDURE FOR FUNCTIONAL CHECK OF REPLACEMENT COMONENTS	
	74

SECTION I

IMPORTANT INFORMATION

A. RECEIVING and HANDLING

The dryer is shipped in a protective stretch wrap cover with protective cardboard corners and top cover (or optional box) as a means of preventing damage in transit. Upon delivery, the dryer and/or packaging, and wooden skid **should be** visually inspected for shipping damage. If any damage whatsoever is noticed, inspect further before delivering carrier leaves.

Dryers damaged in shipment:

1. **ALL** dryers **should be** inspected upon receipt and before they are signed for.
2. If there is suspected damage or actual damage, the trucker's receipt **should be** so noted.
3. If the dryer is damaged beyond repair, it **should be** refused. Those dryers which were not damaged in a damaged shipment **should be** accepted, but the number received and the number refused **must be** noted on the receipt.
4. If you determine that the dryer was damaged after the trucker has left your location, you should call the delivering carrier's freight terminal immediately and file a claim. The freight company considers this concealed damage. This type of freight claim is very difficult to get paid and becomes extremely difficult when more than a day or two passes after the freight was delivered. It is your responsibility to file freight claims. Dryer/parts damaged in transit **cannot** be claimed under warranty.
5. Freight claims are the responsibility of the consignee, and **ALL** claims **must be** filed at the receiving end. **ADC** assumes no responsibility for freight claims or damages.
6. If you need assistance in handling the situation, please contact the **ADC** Traffic Manager at (508) 678-9000.

IMPORTANT: The tumbler section of the dryer **must be** transported and handled in an upright position at all times.

B. SAFETY PRECAUTIONS

WARNING: For your safety, the information in this manual *must be* followed to minimize the risk of fire or explosion or to prevent property damage, personal injury, or loss of life.

WARNING: The dryer must never be operated with any of the back guards, outer tops, or service panels removed. PERSONAL INJURY or FIRE COULD RESULT.

1. **DO NOT** store or use gasoline or other flammable vapors and liquids in the vicinity of this or any other appliance.
2. Purchaser/user should consult the local gas supplier for proper instructions to be followed in the event the user smells gas. The instructions **should be** posted in a prominent location.
3. WHAT TO DO IF YOU SMELL GAS..
 - a. **DO NOT** try to light any appliance.
 - b. **DO NOT** touch any electrical switch.
 - c. **DO NOT** use any phone in your building.
 - d. Clear the room, building, or area of **ALL** occupants.
 - e. Immediately call your gas supplier from a neighbor's phone. Follow the gas supplier's instructions.
 - f. If you **cannot** reach your gas supplier, call the fire department.
4. Installation and service **must be** performed by a qualified installer, service agency, or gas supplier.
5. Dryer(s) **must be** exhausted to the outdoors.
6. Although **ADC** produces a very versatile machine, there are some articles that, due to fabric composition or cleaning method, **should not** be dried in it.

WARNING: Dry only water-washed fabrics. **DO NOT** dry articles spotted or washed in dry cleaning solvents, a combustible detergent, or "all purpose" cleaner.
EXPLOSION COULD RESULT.

WARNING: DO NOT dry rags or articles coated or contaminated with gasoline, kerosene, oil, paint, wax. **EXPLOSION COULD RESULT.**

WARNING: DO NOT dry mop heads. Contamination by wax or flammable solvents will create a fire hazard.

WARNING: *DO NOT* use heat for drying articles that contain plastic, foam, sponge rubber, or similarly textured rubber materials. Drying in a heated basket (tumbler) may damage plastics or rubber and also may be a fire hazard.

7. A program **should be** established for the inspection and cleaning of lint in the heating unit area, exhaust duct work, and inside the dryer. The frequency of inspection and cleaning can best be determined from experience at each location.

WARNING: The collection of lint in the burner area and exhaust duct work can create a potential fire hazard.

8. For personal safety, the dryer **must be** electrically grounded in accordance with local codes and/or the National Electric Code ANSI/NFPA NO. 70-LATEST EDITION.

NOTE: Failure to do so will VOID THE WARRANTY.

9. **UNDER NO CIRCUMSTANCES** should the dryer door switches, lint door switch, heat safety circuit ever be disabled.

WARNING: PERSONAL INJURY or FIRE COULD RESULT.

10. This dryer is not to be used in the presence of dry cleaning solvents or fumes.
11. Remove articles from the dryer as soon as the drying cycle has been completed.

WARNING: Articles left in the dryer after the drying and cooling cycles have been completed can create a fire hazard.

12. **DO NOT** operate steam dryers with more than 125 PSI steam pressure. Excessive steam pressure can damage steam coil and/or harm personnel.
13. Replace leaking flexible hoses or other steam fixtures immediately. **DO NOT** operate the dryer with leaking flexible hoses. **PERSONAL INJURY MAY RESULT.**
14. READ and FOLLOW ALL CAUTION and DIRECTION LABELS ATTACHED TO THE DRYER.

WARNING: YOU MUST DISCONNECT and LOCKOUT THE ELECTRIC SUPPLY and THE GAS SUPPLY or THE STEAM SUPPLY BEFORE ANY COVERS or GUARDS ARE REMOVED FROM THE MACHINE TO ALLOW ACCESS FOR CLEANING, ADJUSTING, INSTALLATION, or TESTING OF ANY EQUIPMENT per OSHA (Occupational Safety and Health Administration) STANDARDS.

SECTION II

SPECIFICATIONS/DIMENSIONS and COMPONENT IDENTIFICATION

A. SPECIFICATIONS (GAS and STEAM Models)

Maximum Capacity (Dry Weight)		310 lbs.	141 kg		
Basket Diameter		62-1/2"	158.75 cm		
Basket Depth		60"	152.4 cm		
Basket Volume		106.5 cu. ft.	3.02 cu. m.		
Drive Motor		5 HP	3.73 kw		
Door Opening (Diameter)		36-3/4" w x 43" h	93.3 cm x 109.2 cm		
Door Sill Height - Level		36-1/2"	92.71 cm		
Compressed Air		80 PSI	5.63 kg/cu.m.		
Compressed Air Connection		3/8" F.P.T.	.953 cm		
Gas*	Voltage Available		208-600v / 3Ø / 3, 4w 50/60Hz		
	Blower Motor		15 HP	11.25 kw	
	Heat Input		1,125,000 btu/hr	283,500 kcal/hr	
	Approx. Weight (Uncrated)		5,100 lbs.	2,313 kg	
	Airflow		6,500 cfm	182.2 cmm	
	Inlet Pipe Size		1-1/2"	3.81 cm	
Steam*	Voltage Available		208-600v / 3Ø / 3, 4w 50/60Hz		
	Blower Motor		25 HP	18.75 kw	
	Approx. Weight (Uncrated)		5,600 lbs.	2,545.5 kg	
	Airflow		8,500 cfm	240.7 cmm	
	Steam Consumption		Boiler HP Normal Load		
	1,153 lbs/hr	524 kg/hr	35		
	Operating Steam Pressure		Steam Supply	Steam Return	
	125 psi max	8.79 kg/sq cm	2"	5.08 cm	1-1/4" 3.18 cm

Shaded areas are stated in metric equivalents.

* Dryers **must be** provided with a clean, dry, regulated 80 PSI (+/- 10 psi) air supply (equivalent volume = 11 cfh).

NOTE: ADC RESERVES THE RIGHT TO MAKE CHANGES IN SPECIFICATIONS AT ANY TIME, WITHOUT NOTICE or OBLIGATION.

**AD-310 TILTING*
1 DOOR/1 WAY TILT
STEAM MODEL**

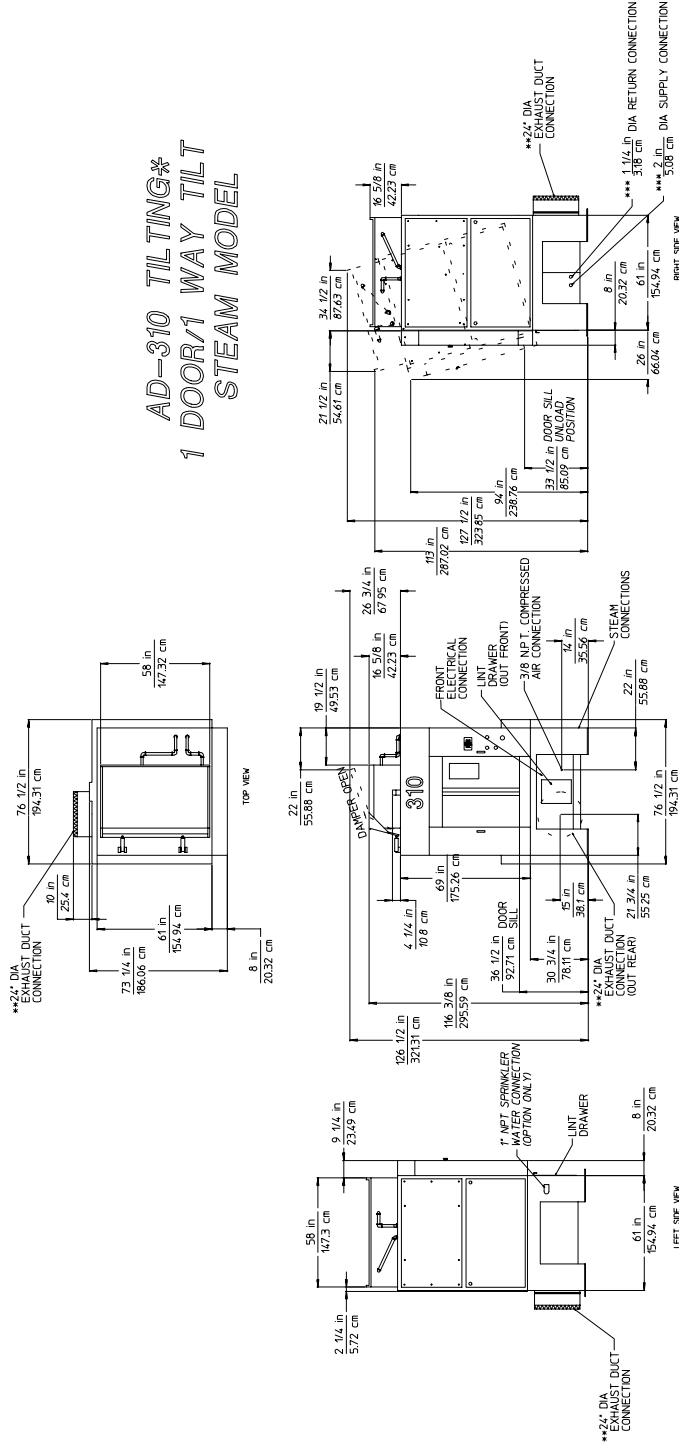

SPEC127

**AD-310 TILTING*
1 DOOR/1 WAY TILT
GAS MODEL**

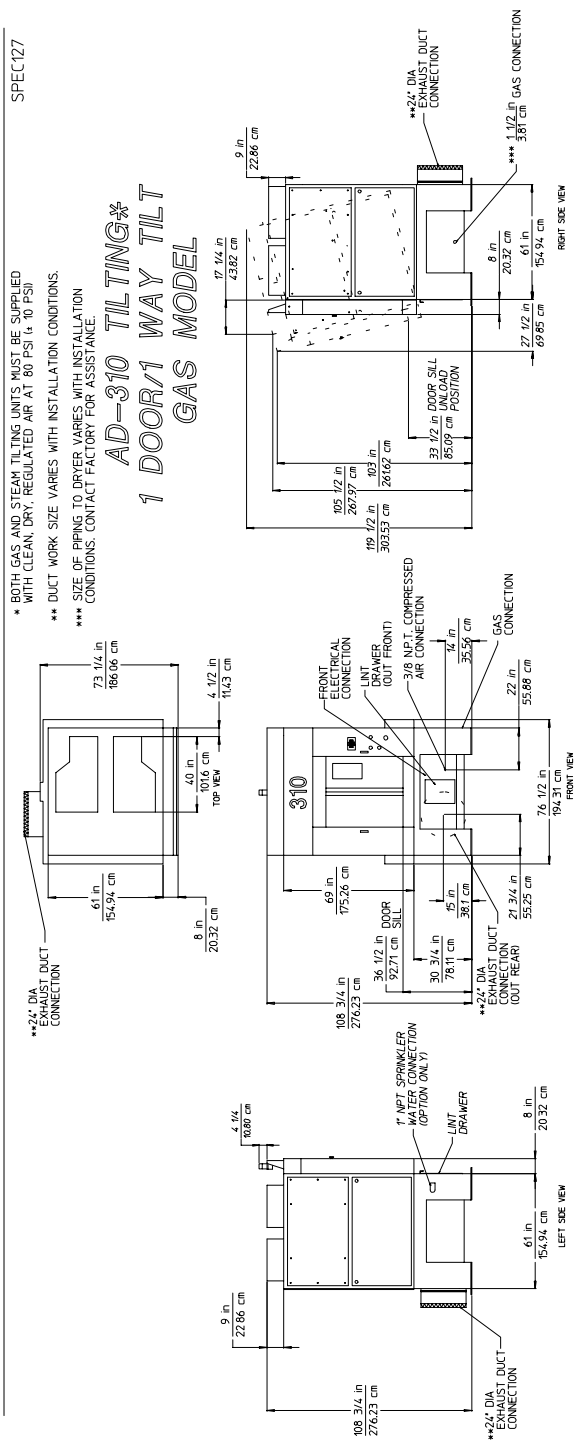

* BOTH GAS AND STEAM TILTING UNITS MUST BE SUPPLIED WITH CLEAN, DRY, REGULATED AIR AT 80 PSI (4.10 PSI)
 ** DUCT WORK SIZE VARIES WITH INSTALLATION CONDITIONS.
 *** SIZE OF PIPING TO DRYER VARIES WITH INSTALLATION CONDITIONS. CONTACT FACTORY FOR ASSISTANCE.

AD-310 TILTING* 1 DOOR/2 WAY TILT STEAM MODEL

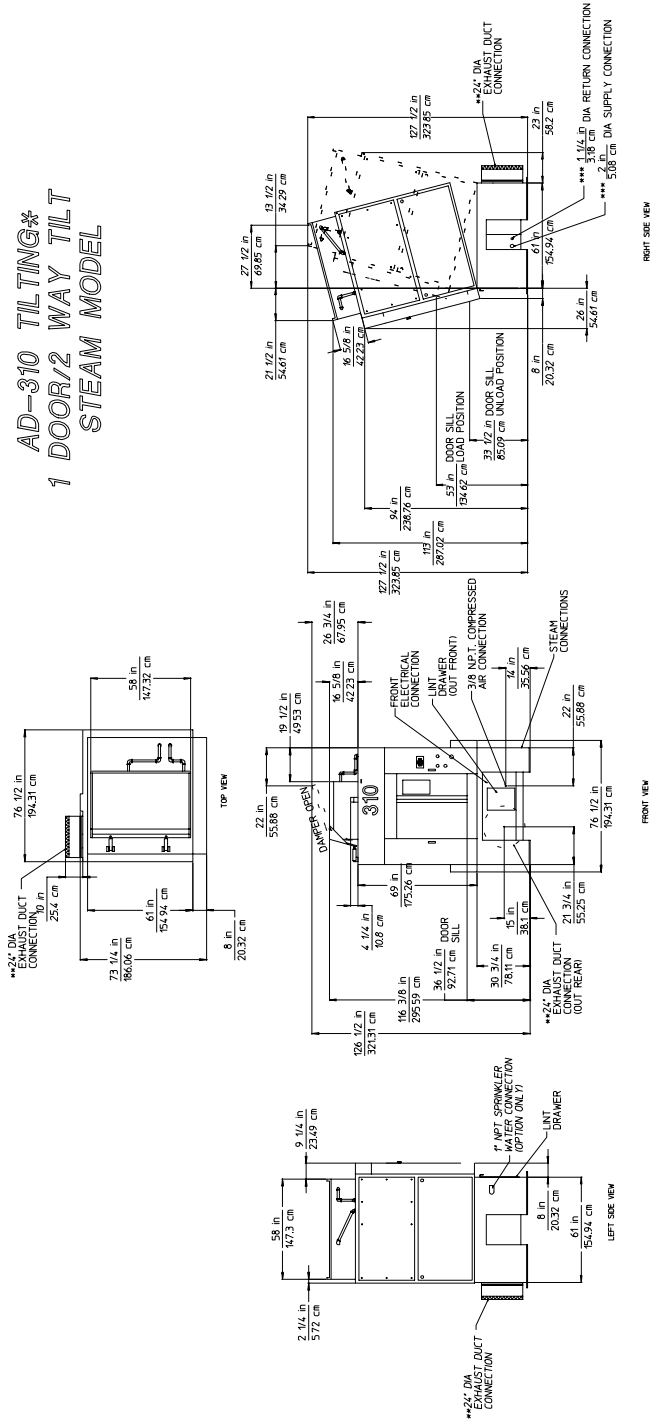

SPEC126

* BOTH GAS AND STEAM TILTING UNITS MUST BE SUPPLIED WITH CLEAN DRY REGULATED AIR AT 80 PSI ± 10 PSI.
** DUCT WORK SIZE VARIES WITH INSTALLATION CONDITIONS.
*** SIZE OF PIPING TO DRYER VARIES WITH INSTALLATION CONDITIONS. CONTACT FACTORY FOR ASSISTANCE.

AD-310 TILTING* 1 DOOR/2 WAY TILT GAS MODEL

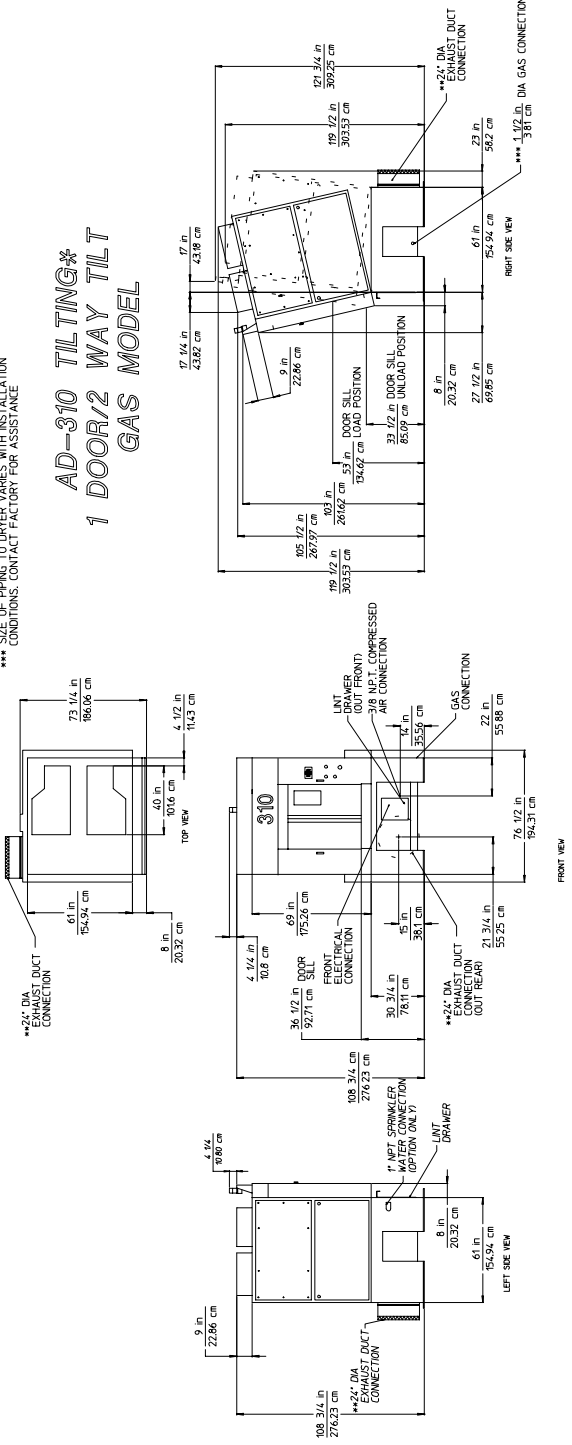

**AD-310 TILTING*
2 DOOR/1 WAY TILT
STEAM MODEL**

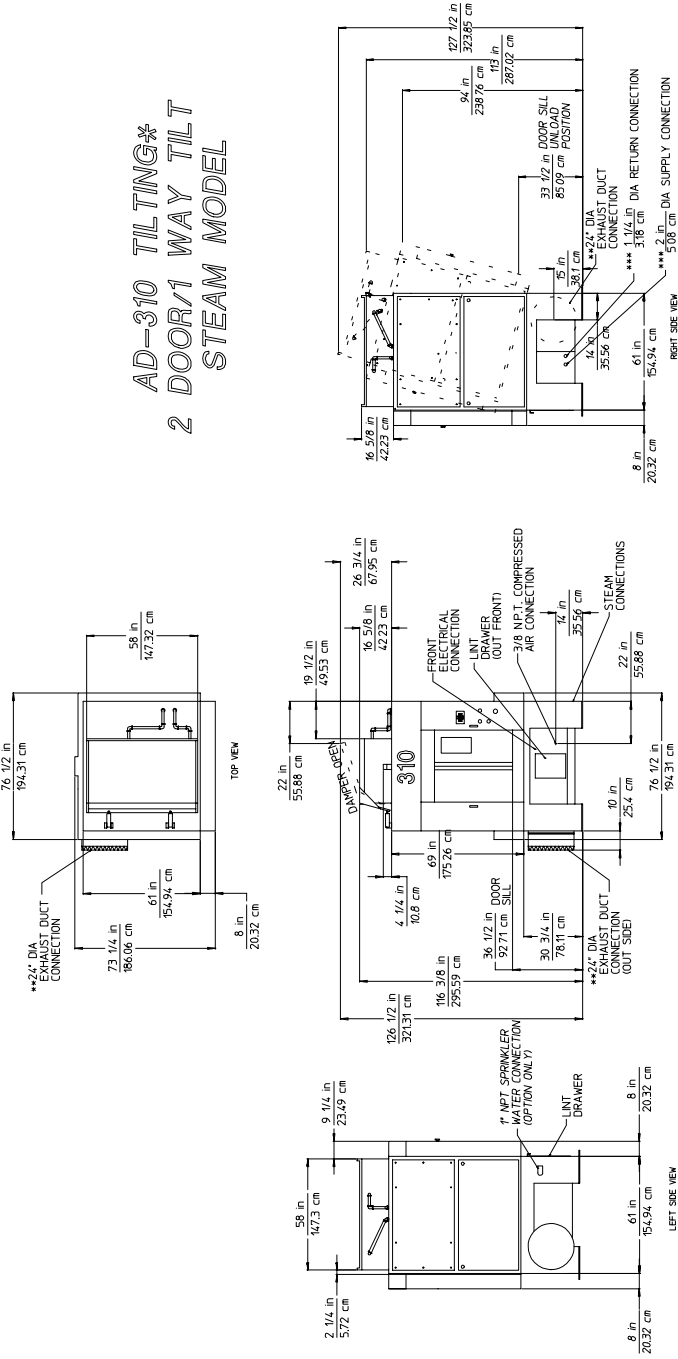

SPEC124

- * BOTH GAS AND STEAM TILTING UNITS MUST BE SUPPLIED WITH CLEAN, DRY, REGULATED AIR AT 80 PSI (4.10 MPa)
- ** DUCT WORK SIZE VARIES WITH INSTALLATION CONDITIONS.
- *** SIZE OF PIPING TO DRYER VARIES WITH INSTALLATION CONDITIONS. CONTACT FACTORY FOR ASSISTANCE.

**AD-310 TILTING*
2 DOOR/1 WAY TILT
GAS MODEL**

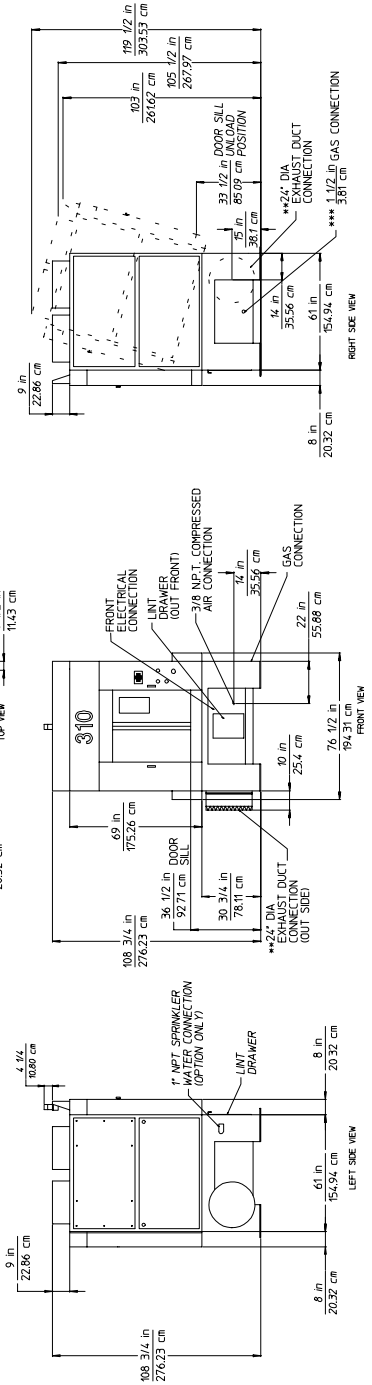

SECTION III

INSTALLATION PROCEDURES

Installation in a proper location **should be** performed by competent technicians in accordance with local and state codes. In the absence of these codes, the installation **must conform** to applicable AMERICAN NATIONAL STANDARDS: ANSI.Z223.1-LATEST EDITION (National Fuel Gas Code) and/or ANSI/NFPA NO. 70-LATEST EDITION (National Electric Code)

A. REASSEMBLY OF DRYER

IMPORTANT: Always keep the tumbler (basket) section of the dryer in an upright position when moving it.

The AD-310 dryer may be shipped one of two ways; as a complete unit fully assembled and ready for hookup or with the tumbler (basket) section separated from the base. If the dryer is shipped in two (2) pieces, the tumbler (basket) section will have to be lifted onto the base. Use cables through the eye bolts on top of the tumbler section, or use a fork lift for the lifting process.

The AD-310 Tilting dryer is made in many loading and unloading options. Please refer to the reassembly instructions on the following pages for your particular style of dryer.

If a steam dryer is shipped in two (2) pieces, the steam coil may have been removed from the top of the tumbler (basket) section and shipped with the base. If this is the case, lift the steam coil on to the top of the tumbler section with the steam pipe connections facing towards the right side of the dryer and bolt the coil to the top of the dryer with the 1/4" hardware supplied. There are three (3) panels that cover the front, right side, and rear of the steam coil. Fasten these in position also. Reconnect the steam and condensate pipe unions to the coil. These pipes run down to the flex hoses in the base.

1. Reassembly Instructions For Gas Dryer Shipped In Two Pieces

ADG-310 1-Door / Forward Tilt

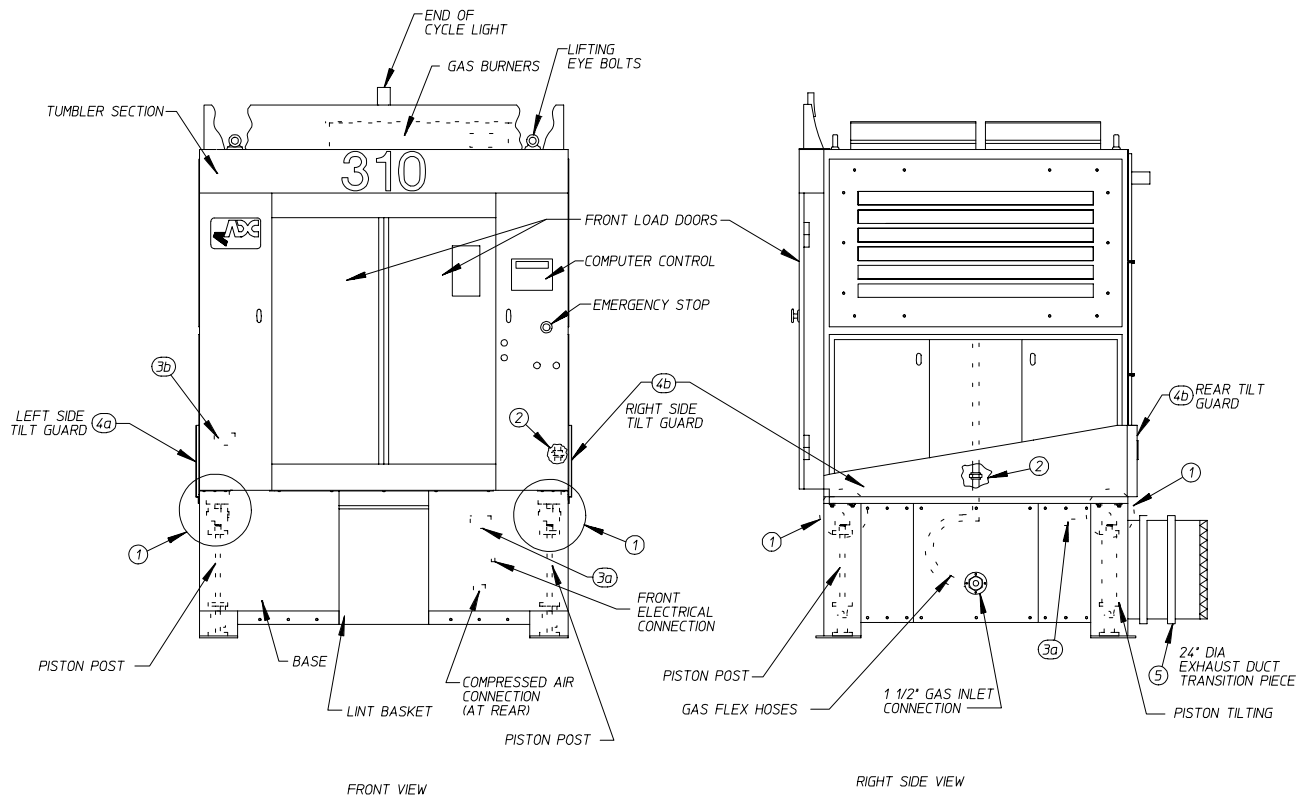

MAN2774

TILTING POST
RECONNECTION VIEW ①

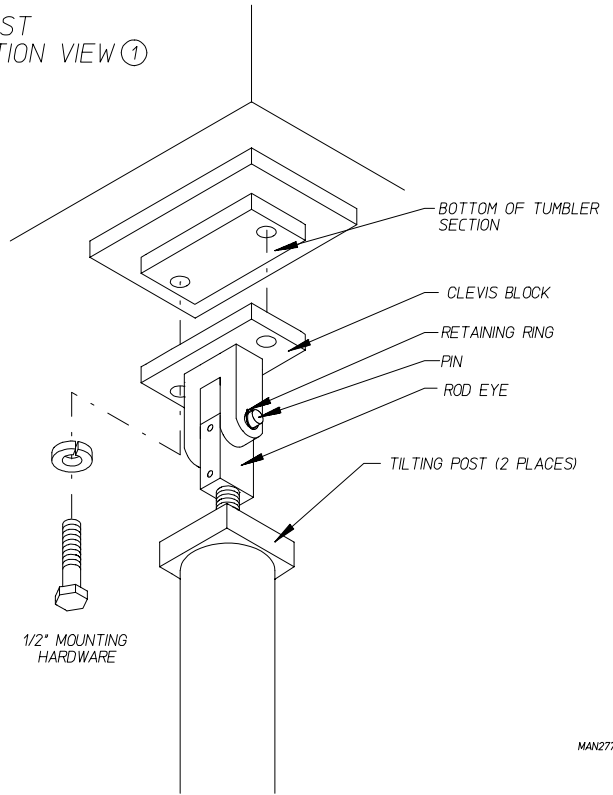

MAN2771

ADG-310 1-Door / Forward Tilt

GAS FLEX HOSE
UNION RECONNECTION
VIEW ②

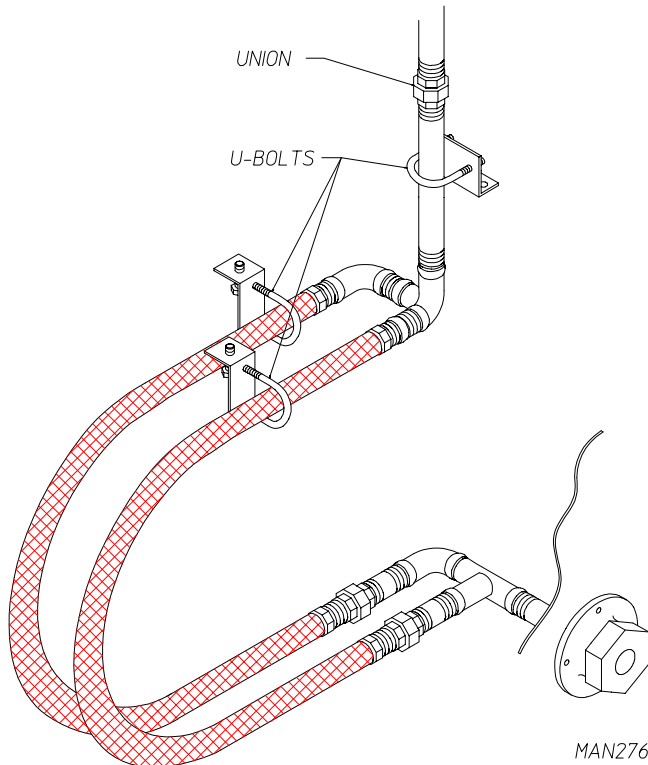

MAN2769

a. Reassembly For 1-Door / Forward Tilt Gas Dryers:

Lift the tumbler (basket) section onto the base.

- 1) Forward Tilt dryers have two (2) tilting pistons in the rear of the base. On the top of each piston is a clevis block. Use the four (4) 1/2" diameter x 1-1/8" long hex head bolts with lock washers to secure each piston clevis block to the bottom of the tumbler section. (Refer to the [top] **View 1** on the previous page [[page 12](#)].)
- 2) The flexible gas hose union is disconnected when the dryer is shipped in two (2) pieces. The flexible gas hoses are located in the right side of the base. Insert the flexible hoses with the union half up through the hole on the bottom of the tumbler section and retighten the union. The flex hoses must not be kinked. (Refer to [bottom] **View 2** on the previous page [[page 12](#)].)
- 3) There are two (2) electrical reconnections:
 - a) A plug and cable is located in the right side of the base. This must be lifted up and reconnected into the mating socket located at the bottom of the right tumbler section.
 - b) The tumbler section power cable **must be** lifted up from the base and reconnected into the junction box next to the tumbler drive motor in the left side of the tumbler section.

Make sure both reconnected cables have enough slack in them to allow the dryer to tilt freely in both directions.

- 4) Reattach the tilt guard panels:
 - a) Use 1/4" self-tapping screws to secure the right side and left side tilt guards.
 - b) Use 1/4" self-tapping screws to secure the rear tilt guards on the rear of the base. Also secure both outside edges of the rear tilt guard to each side guard using sheet metal screws.
- 5) Secure the 24" diameter exhaust duct transition piece to the dryer's rectangular exhaust duct with the 1/4-20 self-tapping screws supplied with the dryer. The exhaust duct exits from the rear of the base.
- 6) On dryers equipped with an automatic (piston operated) load door, reconnect the two (2) poly flow air lines that run from the base up to the door pistons.

2. Reassembly Instructions For Gas Dryer Shipped In Two Pieces

ADG-310 1-Door / 2-Way Tilt

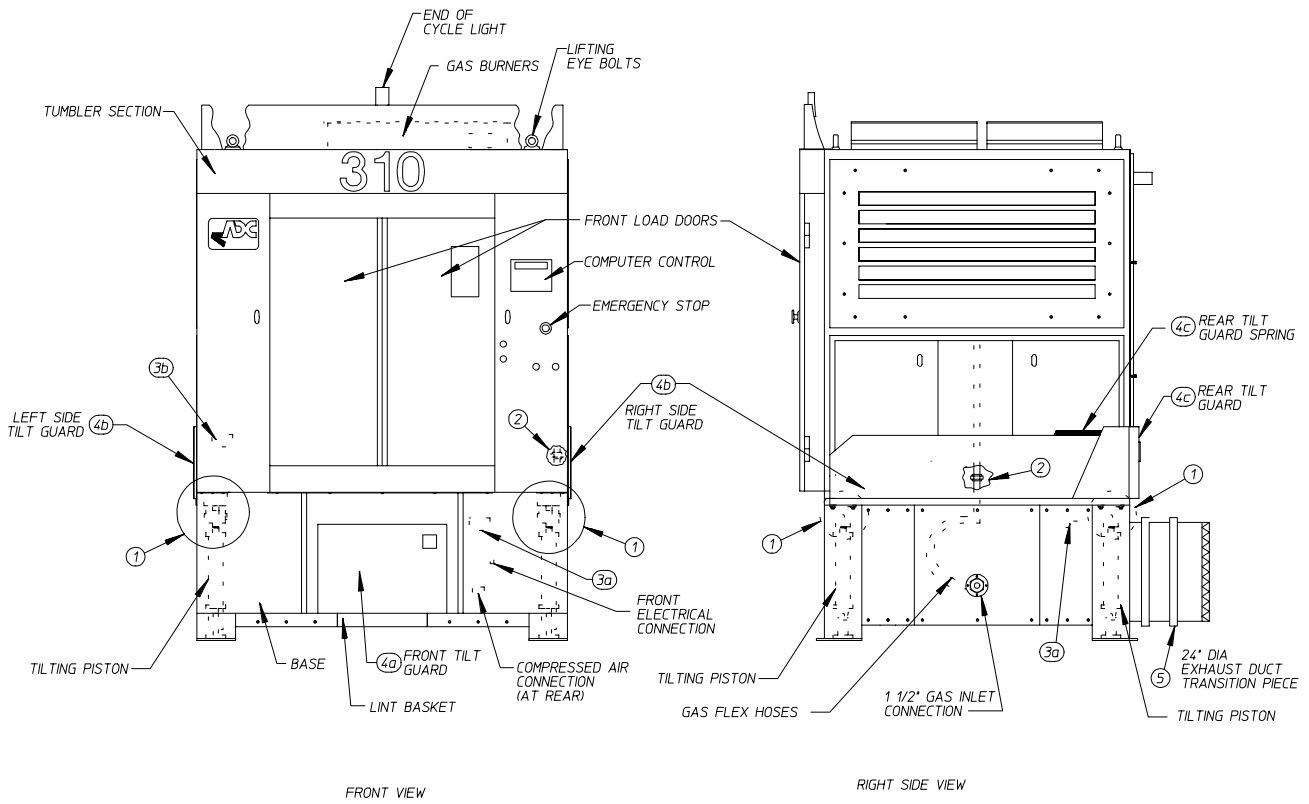

MAN2773

TILTING POST
RECONNECTION VIEW ①

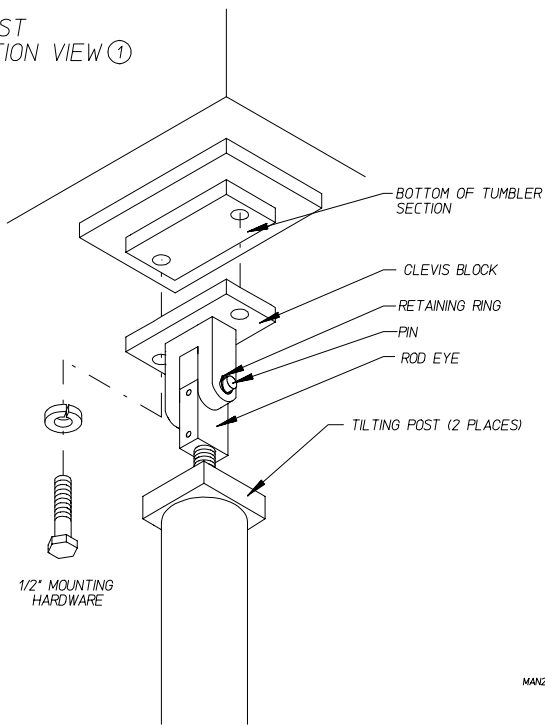

MAN2771

GAS FLEX HOSE
UNION RECONNECTION
VIEW ②

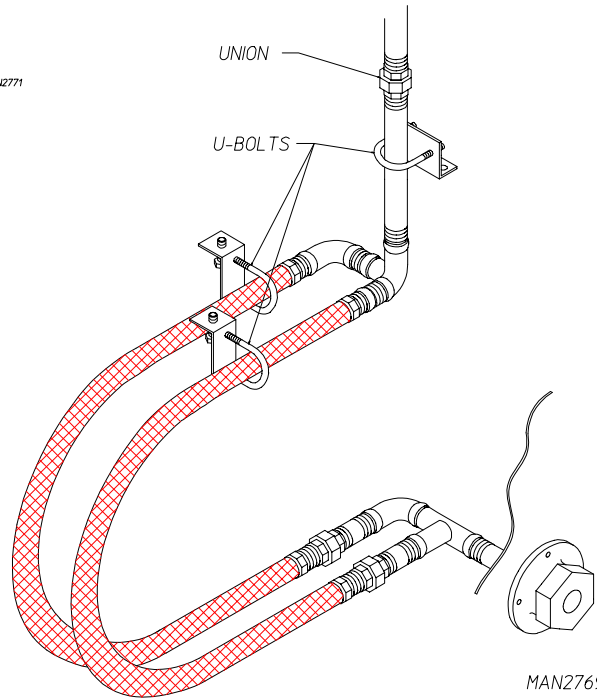

ADG-310 1-Door / 2-Way Tilt

VIEW ③

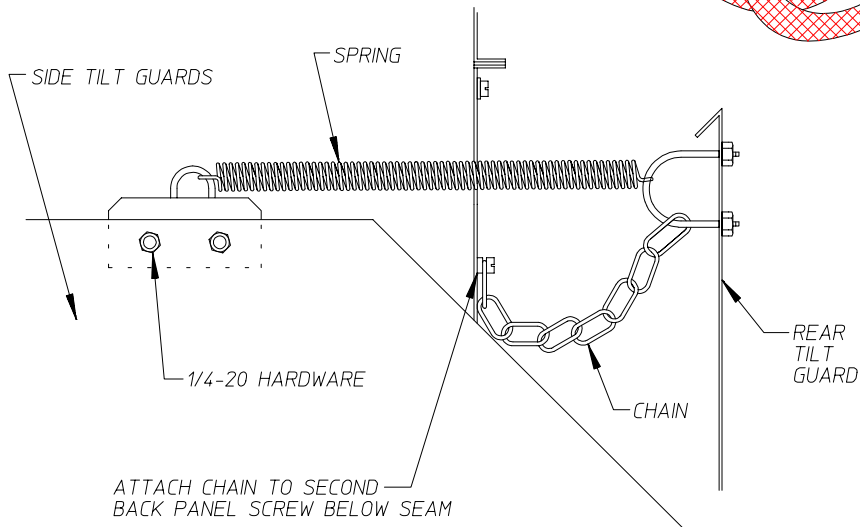

MAN2247

a. Reassembly For 1-Door / 2-Way Tilt Gas Dryers:

Lift the tumbler (basket) section onto the base.

- 1) 2-Way Tilt dryers have four (4) tilting pistons in the base, one (1) on each corner. On the top of each piston is a clevis block. Use the four (4) 1/2" diameter x 1-1/8" long hex head bolts with lock washers to secure each piston clevis block to the bottom of the tumbler section. (Refer to the [top] **View 1** on the previous page [[page 15](#)].)
- 2) The flexible gas hose union is disconnected when the dryer is shipped in two (2) pieces. The flexible gas hoses are located in the right side of the base. Insert the flexible hoses with the union half up through the hole on the bottom of the tumbler section and retighten the union. The flex hoses must not be kinked. (Refer to [bottom] **View 2** on the previous page [[page 15](#)].)
- 3) There are two (2) electrical reconnections:
 - a) A plug and cable is located in the right side of the base. This **must be** lifted up and reconnected into the mating socket located at the bottom of the right tumbler section.
 - b) The drive motor wires **must be** lifted up from the base and reconnected into the junction box next to the tumbler drive motor in the left side of the tumbler section.

Make sure both reconnected cables have enough slack in them to allow the dryer to tilt freely in both directions.

- 4) Reattach the tilt guard panels:
 - a) Use 1/4-20 x 3/8" hex head bolts with lock washers to bolt the top of the front tilt guard up into the bottom of the front of the tumbler section.
 - b) Use 1/4" self-tapping screws to secure the side tilt guards on the top sides of the base.
 - c) Use 1/4" self-tapping screws to secure the rear tilt guards on the rear of the base.

Reconnect the spring and claw assembly which connects the rear tilt guard to each side tilt guard. (Refer to [bottom] View 4c on the previous page [[page 15](#)].) This spring keeps the rear tilt guard close to the dryer's back as the dryer is tilted forward and back.

- d) Reconnect both chains to the back panel.
- 5) Secure the 24" diameter exhaust duct transition piece to the dryer's rectangular exhaust duct with the 1/4-20 self-tapping screws supplied with the dryer. The exhaust duct exits from the rear of the base.
- 6) On dryers equipped with an automatic (piston operated) load door, reconnect the two (2) poly flow air lines that run from the base up to the door pistons.

3. Reassembly Instructions For Gas Dryer Shipped In Two Pieces

ADG-310 2-Door / Rear Tilt (Pass Thru)

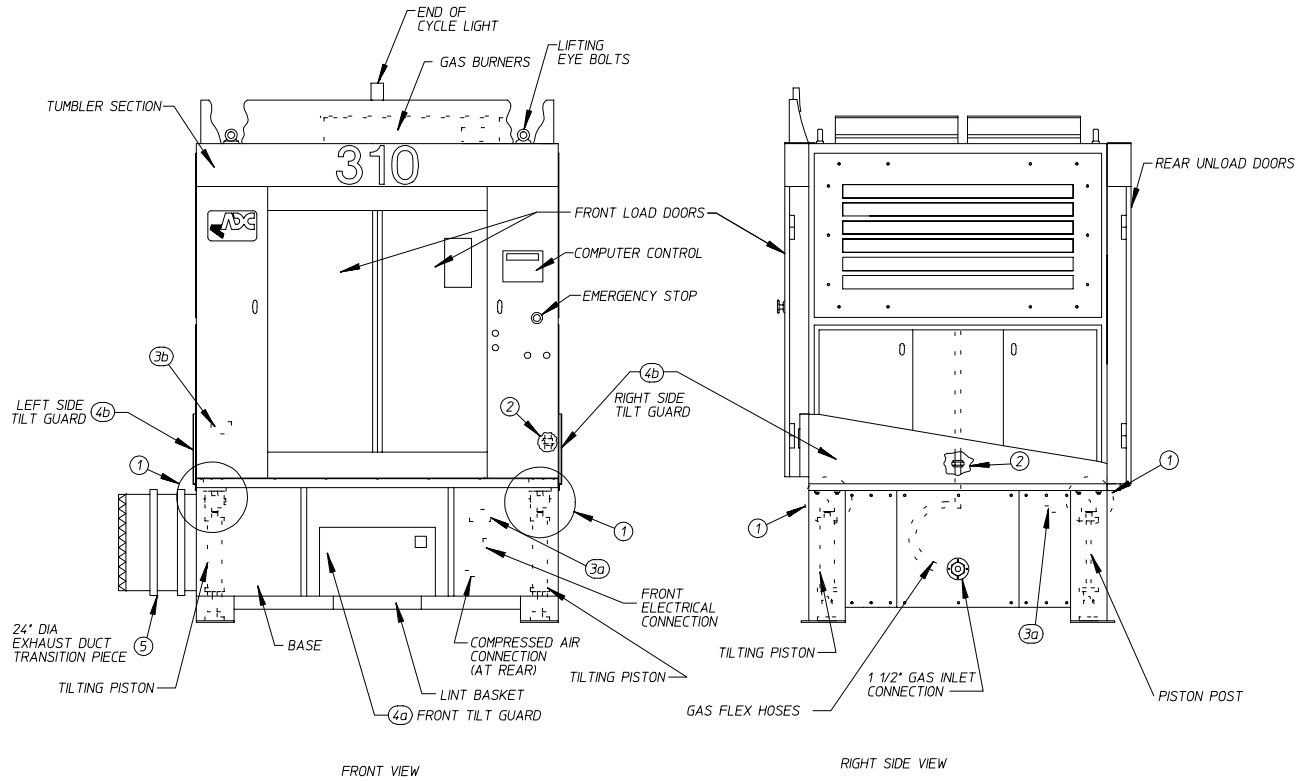

MAN2775

TILTING POST
RECONNECTION VIEW ①

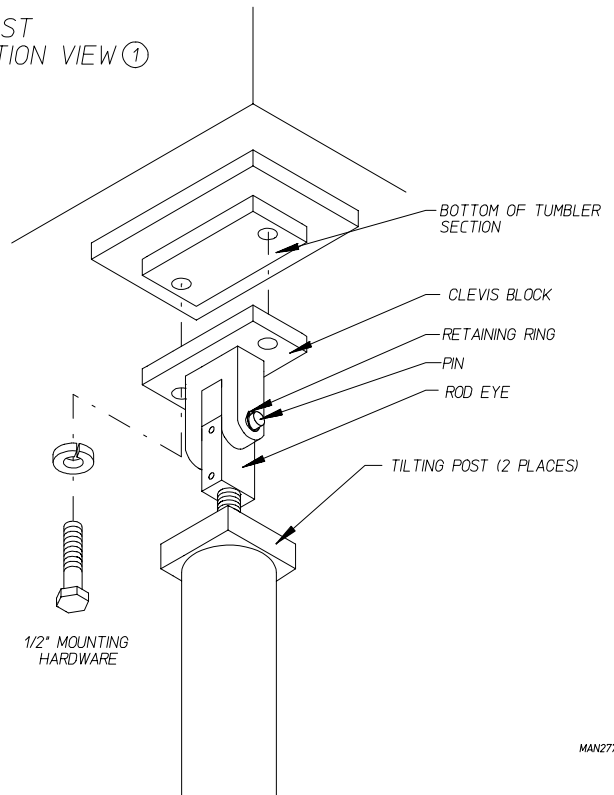

MAN2771

**ADG-310 2-Door / Rear Tilt
(Pass Thru)**

GAS FLEX HOSE
UNION RECONNECTION
VIEW ②

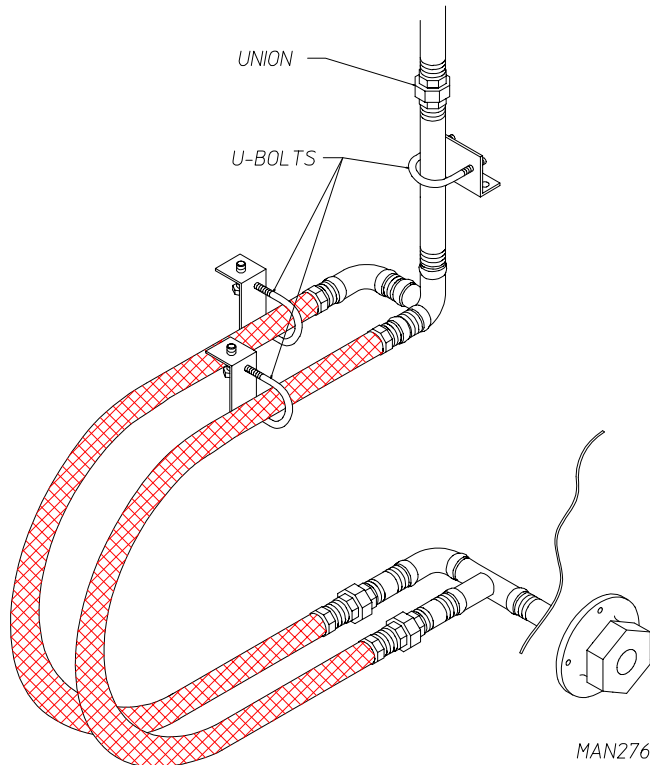

MAN2769

a. Reassembly For 2-Door / Rear Tilt (Pass Thru) Gas Dryers:

Lift the tumbler (basket) section onto the base.

- 1) Rear Tilt dryers have two (2) tilting pistons. The two (2) pistons are in the front corners of the base and there are two (2) piston posts in the rear corners of the base. On the top of both tilting pistons and both piston posts are clevis blocks. Use the four (4) 1/2" diameter x 1-1/8" long hex head bolts with lock washers to secure each clevis block to the bottom of the tumbler section. (Refer to the [top] **View 1** on the previous page [**page 18**].)
- 2) The flexible gas hoses are located in the right side of the base. Insert the flexible hoses with the union half up through the hole on the bottom of the tumbler section and retighten the union. The flex hoses **must not** be kinked. (Refer to [bottom] **View 2** on the previous page [**page 18**].)
- 3) There are two (2) electrical reconnections:
 - a) A plug and cable is located in the right side of the base. This **must be** lifted up and reconnected into the mating socket located at the bottom of the right tumbler section.
 - b) The tumbler section power cable **must be** lifted up from the base and reconnected into the junction box next to the tumbler drive motor in the left side of the tumbler section.

Make sure both reconnected cables have enough slack in them to allow the dryer to tilt freely in both directions.

- 4) Reattach the tilt guard panels:
 - a) Use 1/4-20 x 3/8" hex head bolts with lock washers to bolt the top of the front tilt guard up into the bottom of the front of the tumbler section.
 - b) Use 1/4" self-tapping screws to secure the right side and left side tilt guards.
- 5) Secure the 24" diameter exhaust duct transition piece to the dryer's rectangular exhaust duct with the 1/4-20 self-tapping screws supplied with the dryer. The exhaust duct exits from the left side of the base.
- 6) On dryers equipped with two (2) automatic (piston operated) load and unload doors, reconnect the poly flow air lines that run from the base up to each set of door pistons.

4. Reassembly Instructions For Steam Dryer Shipped In Two Pieces

ADS-310 1-Door / Forward Tilt

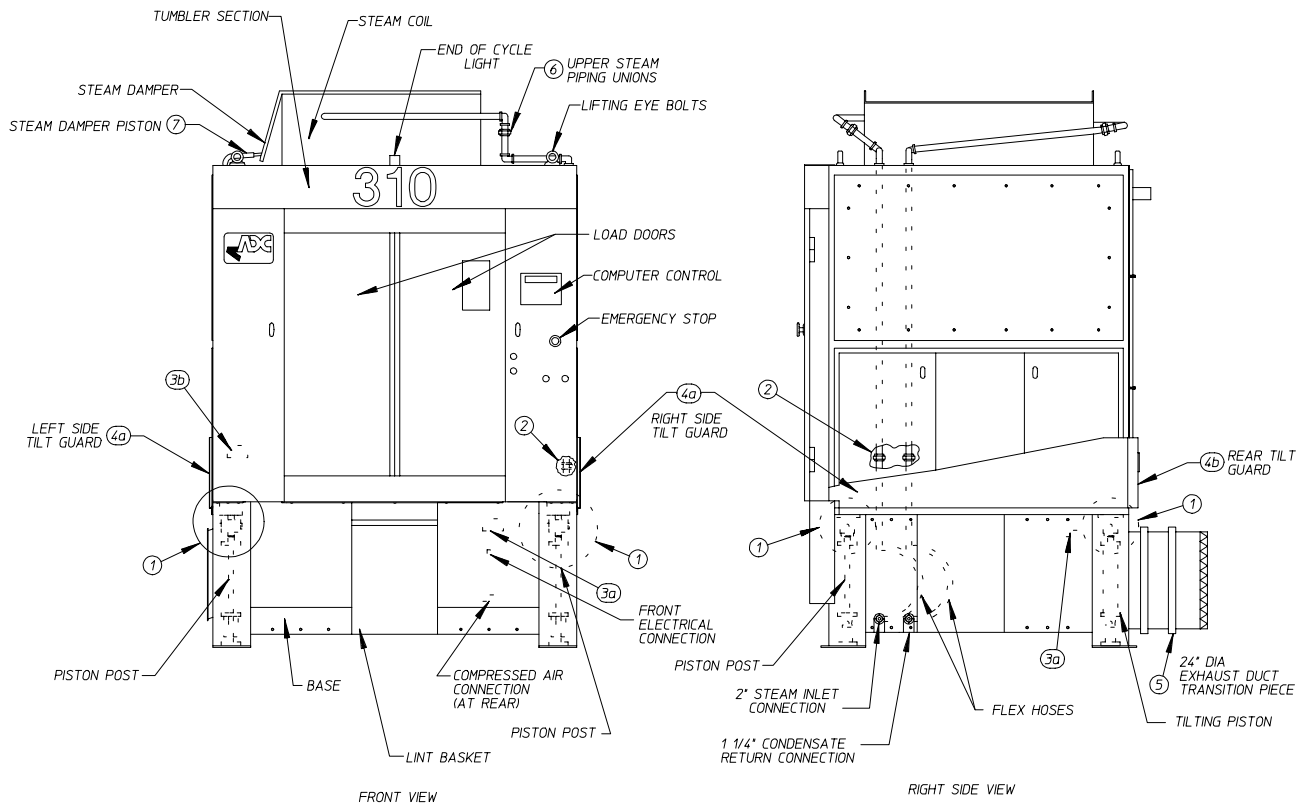

MAN2777

TILTING POST
RECONNECTION VIEW ①

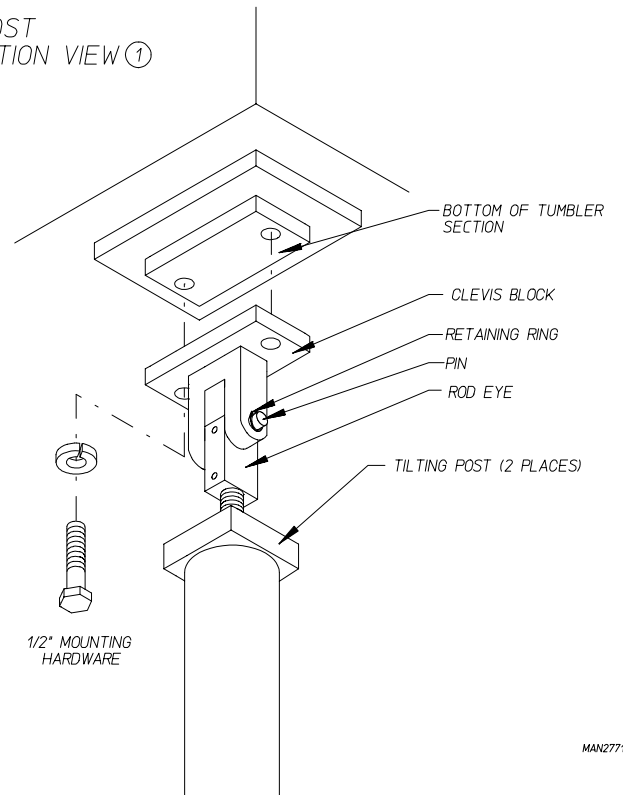

MAN2771

ADS-310 1-Door / Forward Tilt

STEAM FLEX HOSE UNION RECONNECTION
VIEW ②

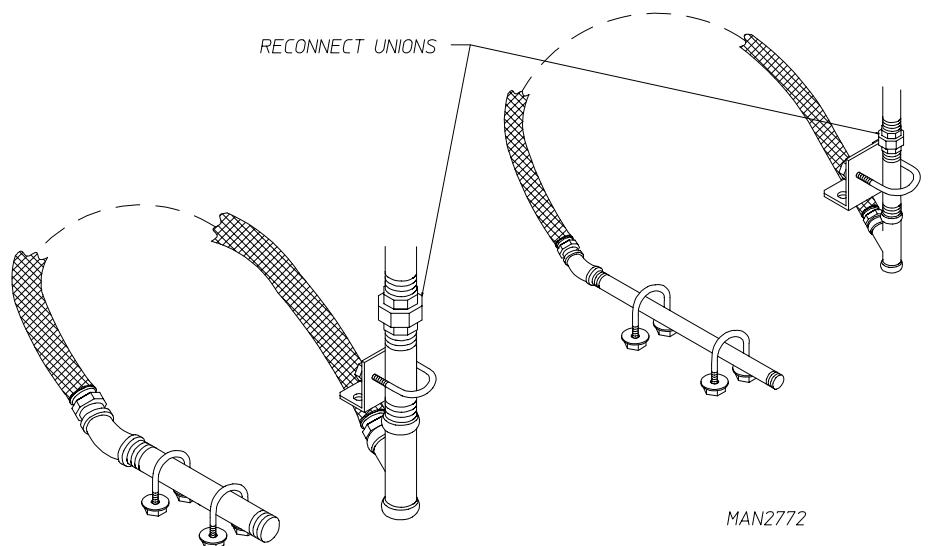

MAN2772

a. Reassembly For 1-Door / Forward Tilt Steam Dryers:

Lift the tumbler (basket) section onto the base.

- 1) Rear Tilt dryers have two (2) tilting pistons. The two (2) pistons are in the front corners of the base and there are two (2) piston posts in the rear corners of the base. On the top of both tilting pistons and both piston posts are clevis blocks. Use the four (4) 1/2" diameter x 1-1/8" long hex head bolts with lock washers to secure each clevis block to the bottom of the tumbler section. (Refer to the [top] **View 1** on the previous page [[page 21](#)].)
- 2) Both the 2" steam supply line and the 1-1/4" condensate return line flexible hose unions are disconnected when the dryer is shipped in two (2) pieces. The flexible hoses are located in the right side of the base. Insert both flexible hose union halves up through the holes on the bottom of the tumbler section and retighten the unions. The flex hoses must not be kinked. (Refer to [bottom] **View 2** on the previous page [[page 21](#)].)
- 3) There are two (2) electrical reconnections:
 - a) A plug and cable is located in the right side of the base. This **must be** lifted up and reconnected into the mating socket located at the bottom of the right tumbler section.
 - b) The tumbler section power cable **must be** lifted up from the base and reconnected into the junction box next to the tumbler drive motor in the left side of the tumbler section.

Make sure both reconnected cables have enough slack in them to allow the dryer to tilt freely in both directions.
- 4) Reattach the tilt guard panels:
 - a) Use 1/4" self-tapping screws to secure the right side and left side tilt guards.
 - b) Use 1/4" self-tapping screws to secure the rear tilt guards on the rear of the base. Also secure both outside edges of the rear tilt guard to each side guard using sheet metal screws.
- 5) Secure the 24" diameter exhaust duct transition piece to the dryer's rectangular exhaust duct with the 1/4-20 self-tapping screws supplied with the dryer. The exhaust duct exits from the left side of the base.
- 6) On dryers equipped with an automatic (piston operated) load door, reconnect the (2) poly flow air lines that run from the base up to the door pistons.
- 7) Reconnect the 1/4" poly flow air line which runs from the base up to the steam damper solenoid valve, which is located on the top of the dryer.

5. Reassembly Instructions For Steam Dryer Shipped In Two Pieces

ADS-310 1-Door / 2-Way Tilt

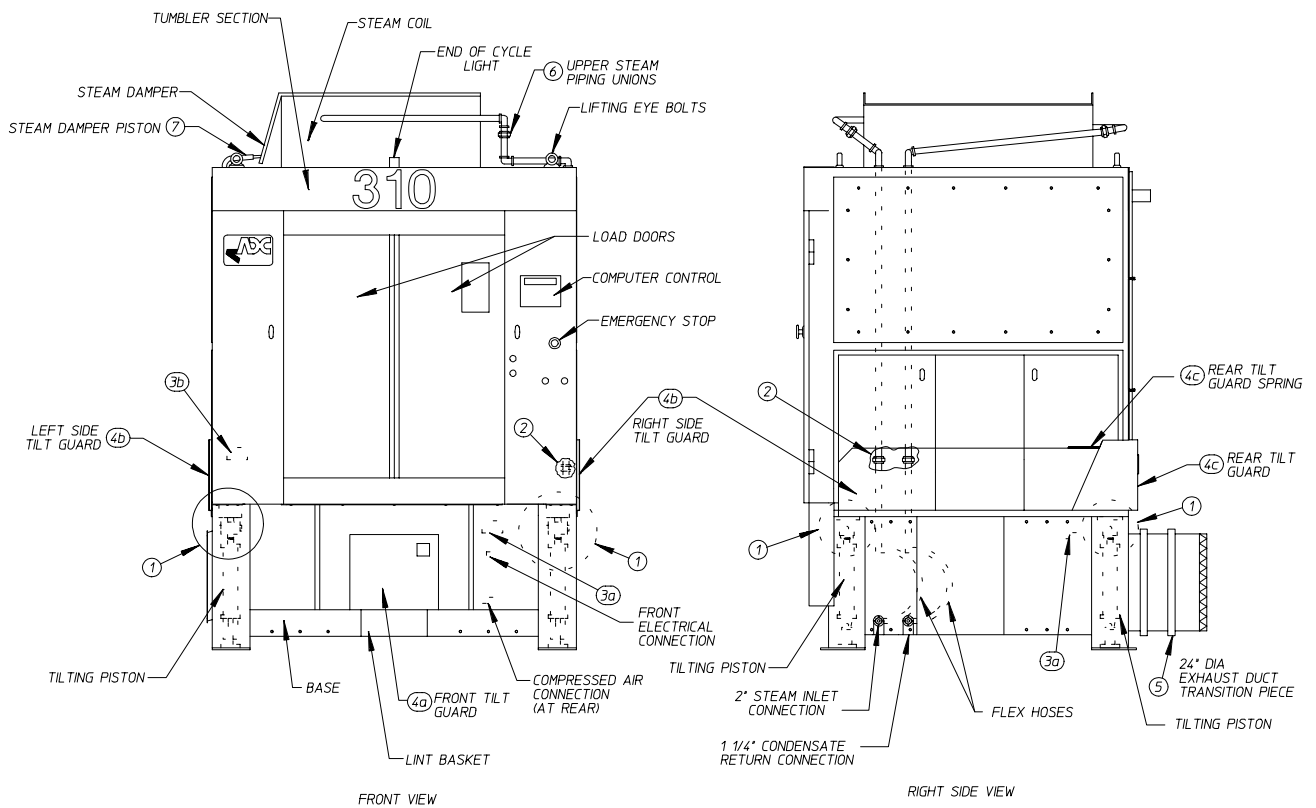

MAN2776

PISTON RECONNECTION
VIEW ①

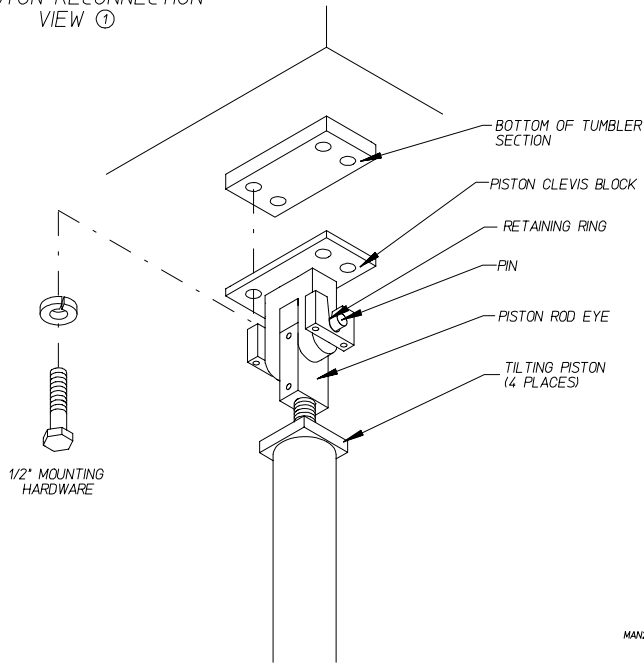

MAN2770

ADS-310 1-Door / 2-Way Tilt

STEAM FLEX HOSE UNION RECONNECTION
VIEW ②

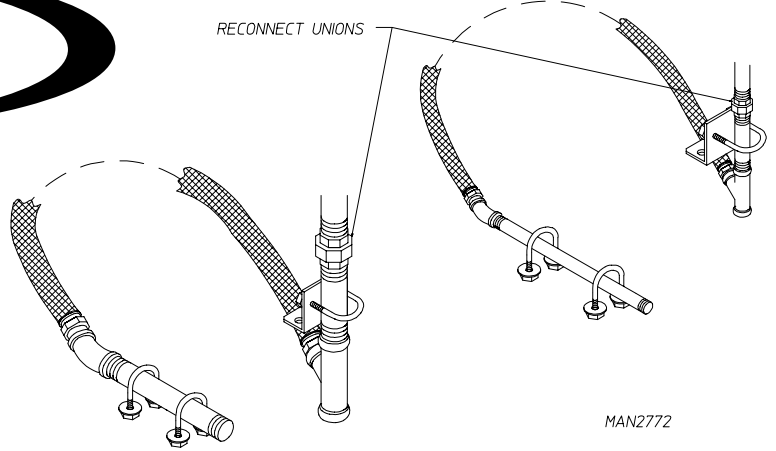

MAN2772

VIEW ③

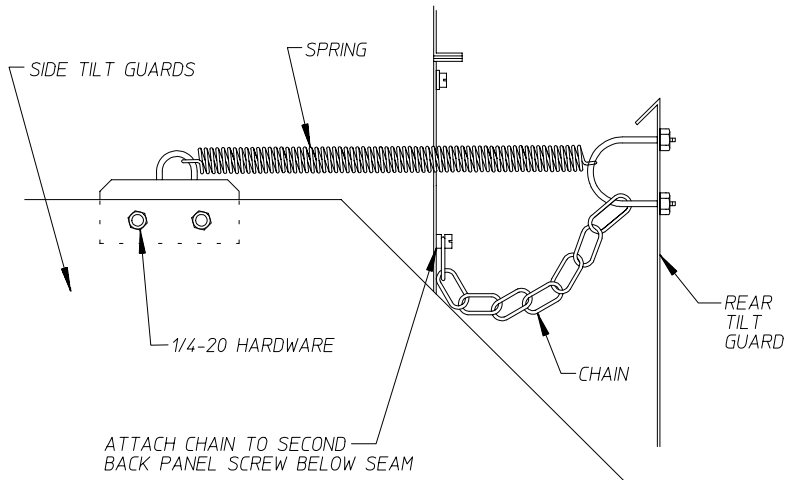

MAN2247

a. Reassembly For 1-Door / 2 Way Tilt Steam Dryers:

Lift the tumbler (basket) section onto the base.

- 1) 2-Way Tilt dryers have four (4) tilting pistons in the base, one (1) on each corner. On the top of each piston is a clevis block. Use the four (4) 1/2" diameter x 1-1/8" long hex head bolts with lock washers to secure each piston clevis block to the bottom of the tumbler section. (Refer to the [top] **View 1** on the previous page [[page 24](#)].)
- 2) Both the 2" steam supply line and the 1-1/4" condensate return line flexible hose unions are disconnected when the dryer is shipped in two (2) pieces. The flexible hoses are located in the right side of the base. Insert both flexible hose union halves up through the holes on the bottom of the tumbler section and retighten the unions. The flex hoses **must not** be kinked. (Refer to [center] **View 2** on the previous page [[page 24](#)].)
- 3) There are two (2) electrical reconnections:
 - a) A plug and cable is located in the right side of the base. This **must be** lifted up and reconnected into the mating socket located at the bottom of the right tumbler section.
 - b) The tumbler section power cable **must be** lifted up from the base and reconnected into the junction box next to the tumbler drive motor in the left side of the tumbler section.

Make sure both reconnected cables have enough slack in them to allow the dryer to tilt freely in both directions.

- 4) Reattach the tilt guard panels:
 - a) Use 1/4-20 x 3/8" hex head bolts with lock washers to bolt the top of the front tilt guard up into the bottom of the front of the tumbler section..
 - b) Use 1/4" self-tapping screws to secure the side tilt guards on the top sides of the base.
 - c) Use 1/4" self-tapping screws to secure the rear tilt guards on the rear of the base.

Reconnect the spring and claw assembly which connects the rear tilt guard to each side tilt guard. (Refer to [bottom] **View 4c** on the previous page [[page 24](#)].) This spring keeps the rear tilt guard close to the dryers' back as the dryer is tilted forward and back.

- d) Reconnect both chains to the back panel.
- 5) Secure the 24" diameter exhaust duct transition piece to the dryer's rectangular exhaust duct with the 1/4-20 self-tapping screws supplied with the dryer. The exhaust duct exits from the left side of the base.
- 6) On dryers equipped with an automatic (piston operated) load door, reconnect the (2) poly flow air lines that run from the base up to the door pistons.
- 7) Reconnect the 1/4" poly flow air line which runs from the base up to the steam damper solenoid valve, which is located on the top of the dryer.

3. Reassembly Instructions For Steam Dryer Shipped In Two Pieces

ADS-310 2-Door / Rear Tilt (Pass Thru)

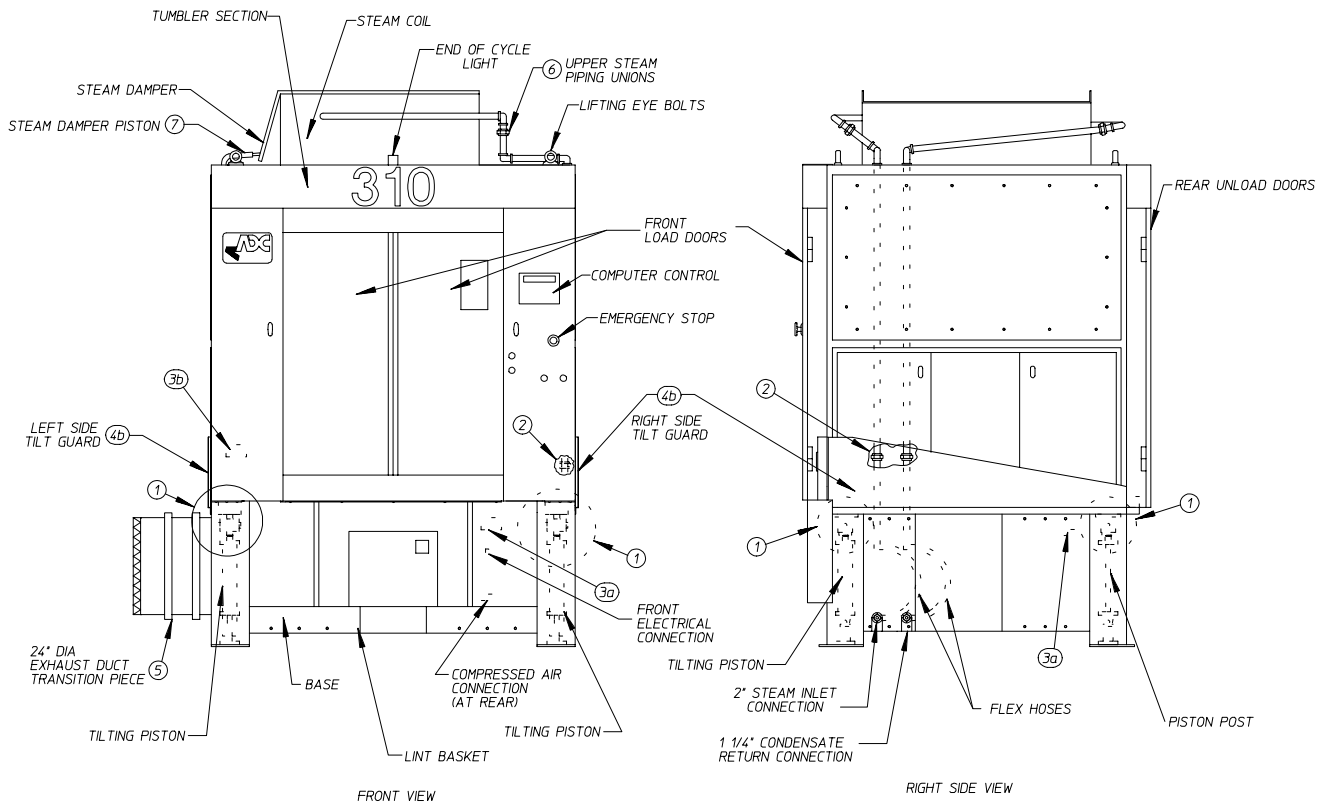

MAN2778

TILTING POST
RECONNECTION VIEW ①

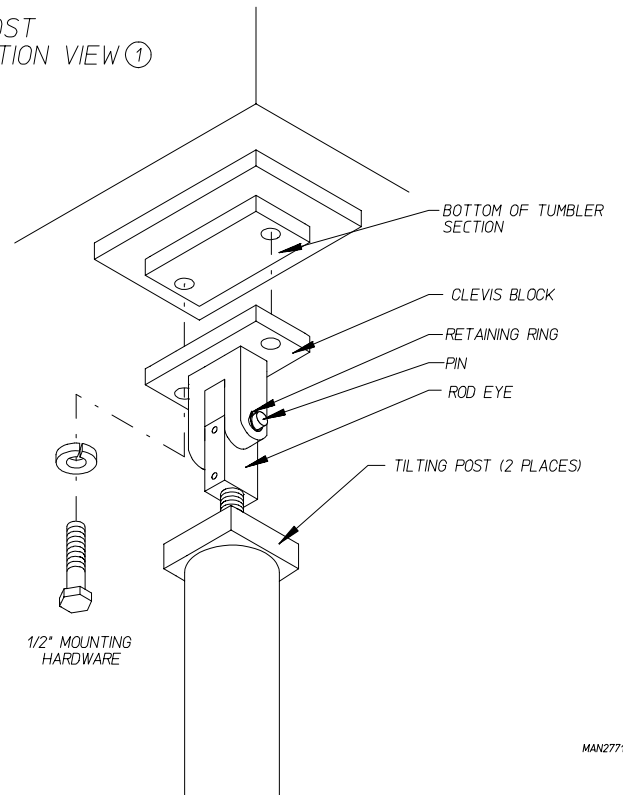

MAN2771

**ADS-310 2-Door / Rear Tilt
(Pass Thru)**

STEAM FLEX HOSE UNION RECONNECTION
VIEW ②

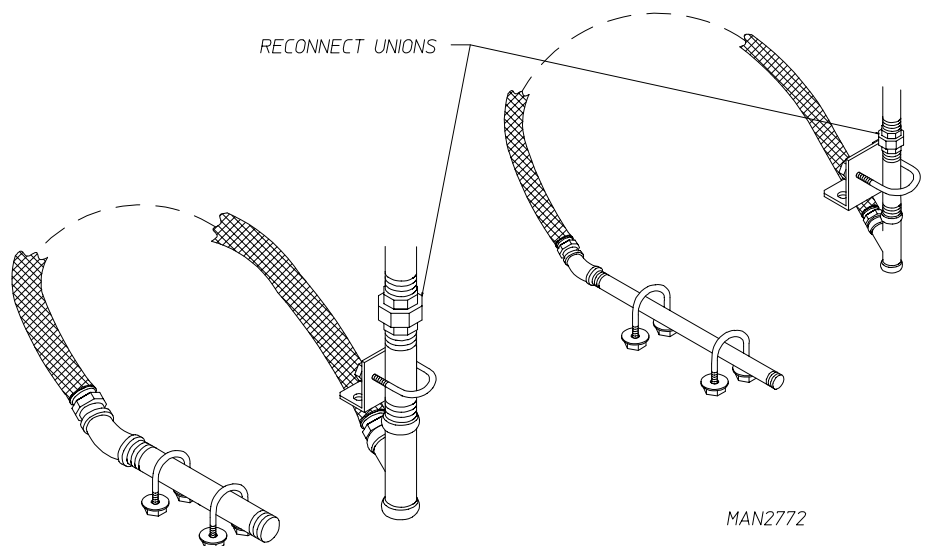

MAN2772

a. Reassembly For 2-Door / Rear Tilt (Pass Thru) Steam Dryers:

Lift the tumbler (basket) section onto the base.

- 1) Rear Tilt dryers have two (2) tilting pistons. The two (2) pistons are in the front corners of the base and there are two (2) piston posts in the rear corners of the base. On the top of both tilting pistons and both piston posts are clevis blocks. Use the four (4) 1/2" diameter x 1-1/8" long hex head bolts with lock washers to secure each clevis block to the bottom of the tumbler section. (Refer to the [top] **View 1** on the previous page [[page 27](#)].)
- 2) Both the 2" steam supply line and the 1-1/4" condensate return line flexible hose unions are disconnected when the dryer is shipped in two (2) pieces. The flexible hoses are located in the right side of the base. Insert both flexible hose union halves up through the holes on the bottom of the tumbler section and retighten the unions. The flex hoses **must not** be kinked. (Refer to [bottom] **View 2** on the previous page [[page 27](#)].)
- 3) There are two (2) electrical reconnections:
 - a) A plug and cable is located in the right side of the base. This **must be** lifted up and reconnected into the mating socket located at the bottom of the right tumbler section.
 - b) The tumbler section power cable **must be** lifted up from the base and reconnected into the junction box next to the tumbler drive motor in the left side of the tumbler section.

Make sure both reconnected cables have enough slack in them to allow the dryer to tilt freely in both directions.
- 4) Reattach the tilt guard panels:
 - a) Use 1/4-20 x 3/8" hex head bolts with lock washers to bolt the top of the front tilt guard up to the bottom of the front of the tumbler section.
 - b) Use 1/4" self-tapping screws to secure the right side and left side tilt guards.
- 5) Secure the 24" diameter exhaust duct transition piece to the dryer's rectangular exhaust duct with the 1/4-20 self-tapping screws supplied with the dryer. The exhaust duct exits from the rear of the base.
- 6) On dryers equipped with an automatic (piston operated) load door, reconnect the (2) poly flow air lines that run from the base up to the door pistons.
- 7) Reconnect the 1/4" poly flow air line which runs from the base up to the steam damper solenoid valve, which is located on the top of the dryer.

B. LOCATION REQUIREMENTS

The model AD-310 tilting dryer requires 18-inches of space on each side of the dryer for ease of maintenance. For an AD-310 Forward Tilting model, a 24-inch clearance behind the dryer is required; for an AD-310 Rear Tilting or an AD-310 2-Way Tilt model, a 36-inch clearance behind the dryer is required for servicing the dryer. Refer to the chart below for ceiling height requirements for each of the AD-310 Tilting dryer models.

The dryer **must be** leveled for proper operation. If shimming is required, put metal shims which are the same size as the base feet under the base feet. The dryer **must be** lagged to the floor.

AD-310 TILT CLEARANCE ALLOWANCE		
Dryer Style		Ceiling Height Requirement
Gas	ADG-310 1-Door / Forward Tilt	122-inches
	ADG-310 1-Door / 2-Way Tilt	126-inches
	ADG-310 2-Door / Rear Tilt	126-inches
Steam	ADS-310 1-Door / Forward Tilt	132-inches
	ADS-310 1-Door / 2-Way Tilt	132-inches
	ADS-310 2-Door / Rear Tilt	132-inches

WARNING: Dryer *should be* located where a minimum length of exhaust duct will be necessary.

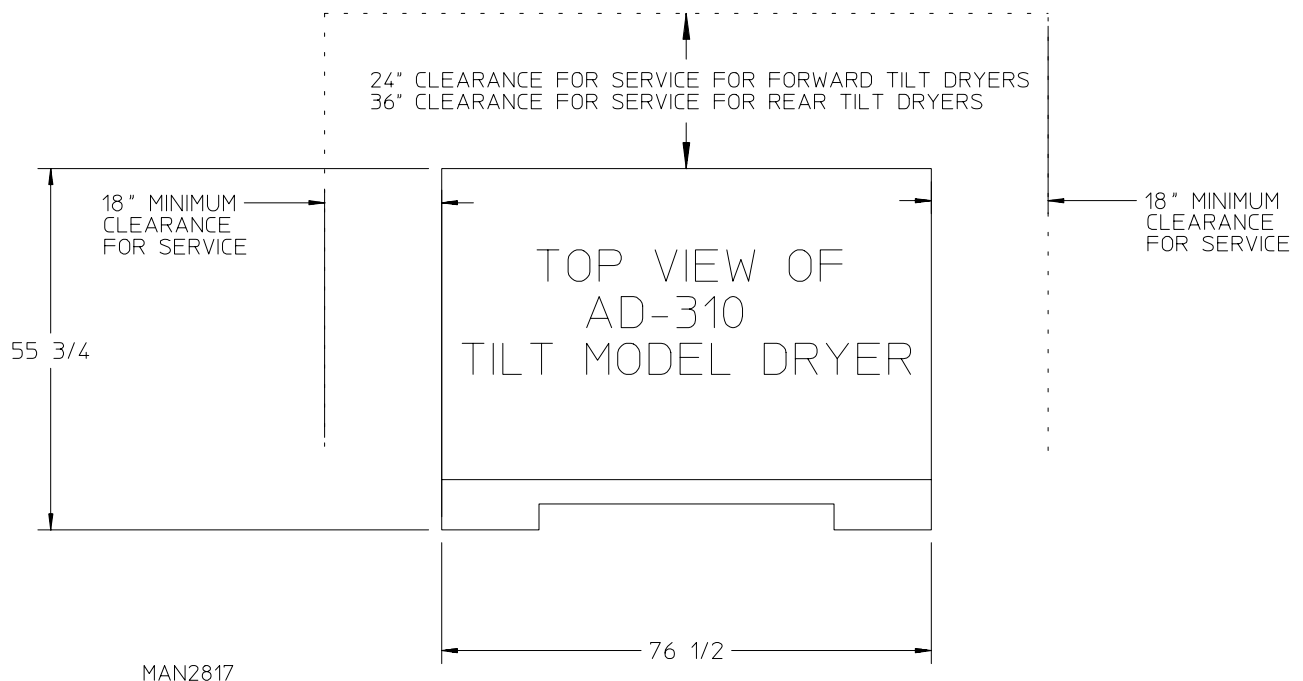

C. FRESH AIR SUPPLY REQUIREMENTS

When the dryer is operating, it draws in room air, heats it, passes this air through the basket (tumbler), and exhausts it out of the building. Therefore, the room air **must be** continually replenished from the outdoors. If the make-up air is inadequate, drying time and drying efficiency will be adversely affected. Ignition problems and sail switch "fluttering" problems may result, as well as premature motor failure from overheating.

Air supply (make-up air) **must be** given careful consideration to assure proper performance of each dryer. An unrestricted source of air is necessary for each dryer. An airflow of 6,500 cfm (cubic feet per minute) **must be** supplied to each gas dryer and 8,500 cfm for each steam dryer. As a general rule, an unrestricted air entrance from the outdoors (atmosphere) of a minimum of six (6) square feet is required for each gas dryer and a minimum of eight (8) square feet for each steam dryer.

To compensate for the use of registers or louvers used over the openings, this make-up air area **must be** increased by approximately thirty-three percent (33%). Make-up air openings **should not** be located in an area directly near where exhaust vents exit the building.

It is not necessary to have a separate make-up air opening for each dryer. Common make-up air openings are acceptable. However, they **must be** set up in such a manner that the make-up air is distributed equally to **ALL** the dryers.

Allowances **must be** made for remote or constricting passageways or where dryers are located at excessive altitudes or predominantly low pressure areas.

IMPORTANT: Make-up air *must be* provided from a source free of dry cleaning solvent fumes. Make-up air that is contaminated by dry cleaning solvent fumes will result in irreparable damage to the motors and other dryer components.

NOTE: Component failure due to dry cleaning solvent fumes will VOID THE WARRANTY.

D. EXHAUST REQUIREMENTS

NOTE: For one door AD-310 dryers, the 24-inch diameter exhaust duct exits from the rear of the base. For two door dryers, the 24-inch diameter exhaust duct exits from the left side of the base.

1. GENERAL EXHAUST DUCT WORK INFORMATION

Exhaust duct work **should be** designed and installed by a qualified professional. Improperly sized duct work will create excessive back pressure which results in slow drying, increased use of energy, overheating of the dryer, and shutdown of the burner by the airflow (sail) switches, burner hi-limits, or basket (tumbler) hi-heat thermostats.

CAUTION: DRYER ***MUST BE*** EXHAUSTED TO THE OUTDOORS.

CAUTION: IMPROPERLY SIZED OR INSTALLED EXHAUST DUCT WORK CAN CREATE A POTENTIAL FIRE HAZARD.

NOTE: When a dryer is exhausted separately, it is recommended that a back draft damper be installed.

NOTE: THE AD-310 ***MUST BE*** INDEPENDENTLY EXHAUSTED. COMMON DUCT WORK IS NOT ACCEPTABLE.

The exhaust duct work **should be** laid out in such a way that the duct work travels as directly as possible to the outdoors with as few turns as possible. Single or independent dryer venting is recommended.

The shape of the duct work is not critical so long as the minimum cross section area is provided. It is suggested that the use of 90° turns in ducting be avoided; use 30° and/or 45° angles instead. The radius of the elbows should preferably be 1-1/2 times the diameter of the duct.

ALL duct work **should be** smooth inside with no projections from sheet metal screws or other obstructions which will collect lint. When adding ducts, the ducts to be added should overlap the duct to which it is connected. **ALL** duct work joints **must be** taped to prevent moisture and lint from escaping into the building. Additionally, inspection doors **should be** installed at strategic points in the exhaust duct work for periodic inspection and clean-out of lint from the duct work.

The internal dimensions of the dryer's rectangular exhaust vent duct work is 8-1/2" by 21" (20.6 cm x 53.5 cm). A transition piece to 24-inches (61 cm) diameter round is supplied. The location's exhaust duct **must be** at least 24-inches (61 cm) in diameter or, for a rectangular duct, have a cross-sectional area of 452 square inches (2,740 sq.cm.). With the minimum size requirement (24-inch round duct or 452 square inch square duct) the duct work from the dryer to the outside exhaust outlet for a horizontal run with no more than one (1) elbow **must not** exceed 43 feet (refer to the **illustration below**). For locations with more than one (1) elbow, the minimum exhaust size **must be** 28-inches. For a 28-inch round duct (615 square inch duct) the horizontal or vertical duct total run **must not** exceed 29 feet which includes the use of no more than three (3) elbows (refer to the **illustration on page 33** and on **page 34**). Should more than the maximum number of elbows be used or if the run exceeds the maximum limits noted, a professional HVAC firm **should be** consulted for proper venting information.

IMPORTANT: For extended duct work runs or where more than the specified number of elbows are used, a professional HVAC firm *should be* contacted for proper venting information.

NOTE: For extended duct work runs, the cross sectional area of a duct can only be increased to an extent. In some cases the addition of a booster fan in the duct work may be necessary.

HORIZONTAL DRYER VENTING

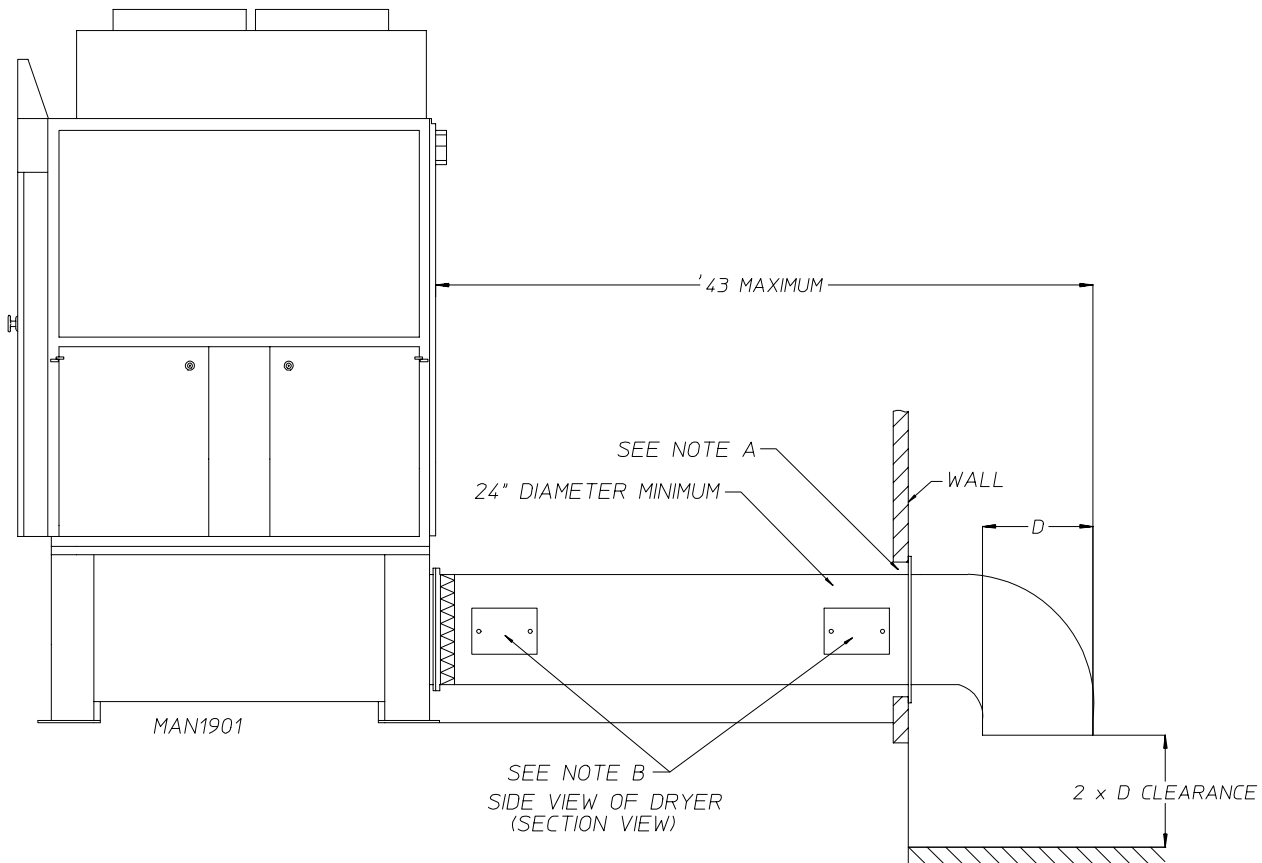

NOTE: "A"- OPENING MUST BE TWO (2) INCHES LARGER THAN DUCT (ALL THE WAY AROUND). THE DUCT MUST BE CENTERED WITHIN THIS OPENING.
 "B"- INSPECTION DOORS SHOULD BE INSTALLED AT STRATEGIC POINTS FOR PERIODIC INSPECTION AND CLEANING

VERTICAL DRYER VENTING

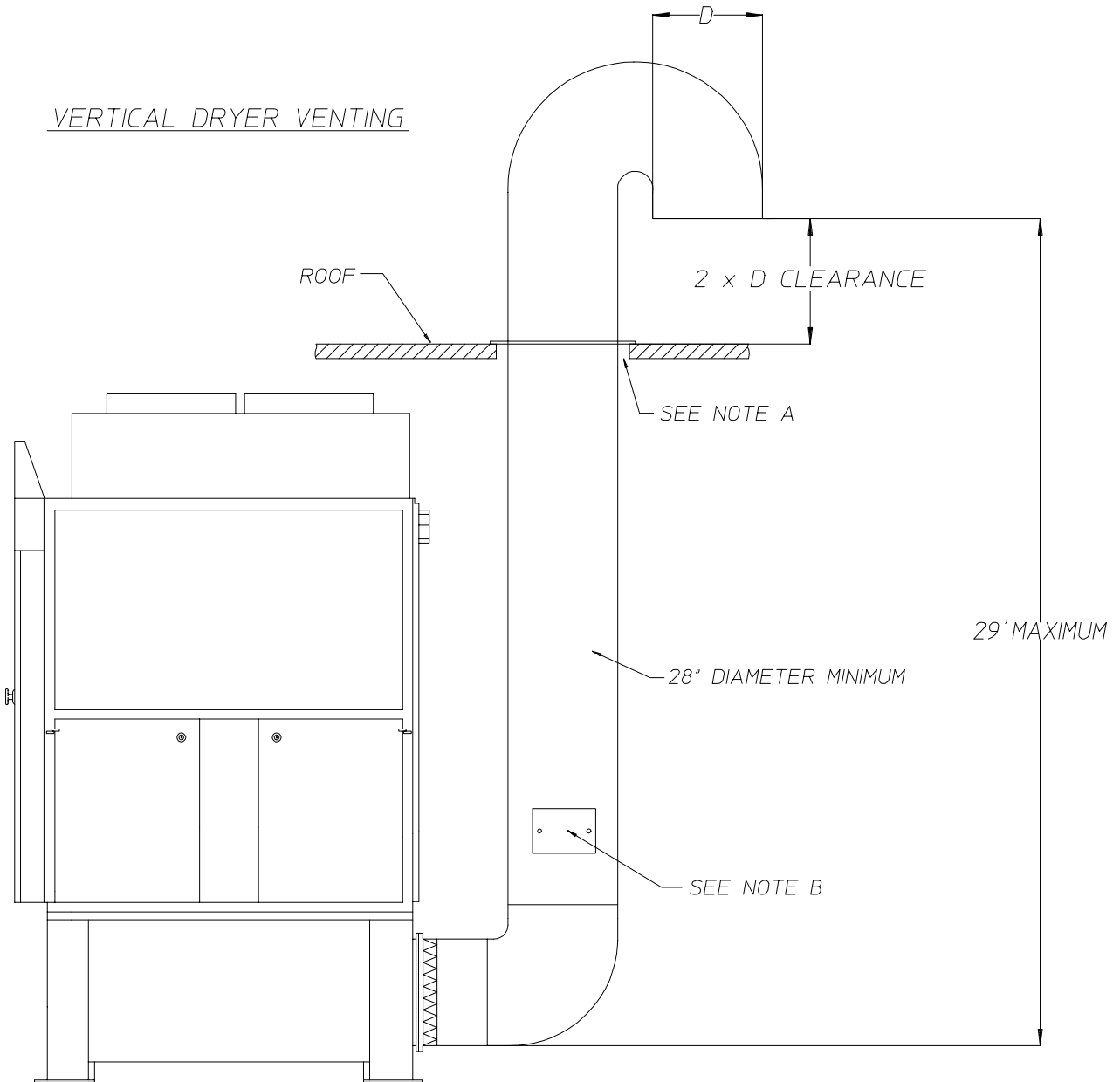

SIDE VIEW OF DRYER
(SECTION VIEW)

MAN1902

- NOTE: "A"- OPENING MUST BE TWO (2) INCHES LARGER THAN DUCT
(ALL THE WAY AROUND). THE DUCT MUST BE CENTERED
WITHIN THIS OPENING.
- "B"- INSPECTION DOORS SHOULD BE INSTALLED AT
STRATEGIC POINTS FOR PERIODIC INSPECTION
AND CLEANING

VERTICAL/HORIZONTAL DRYER VENTING

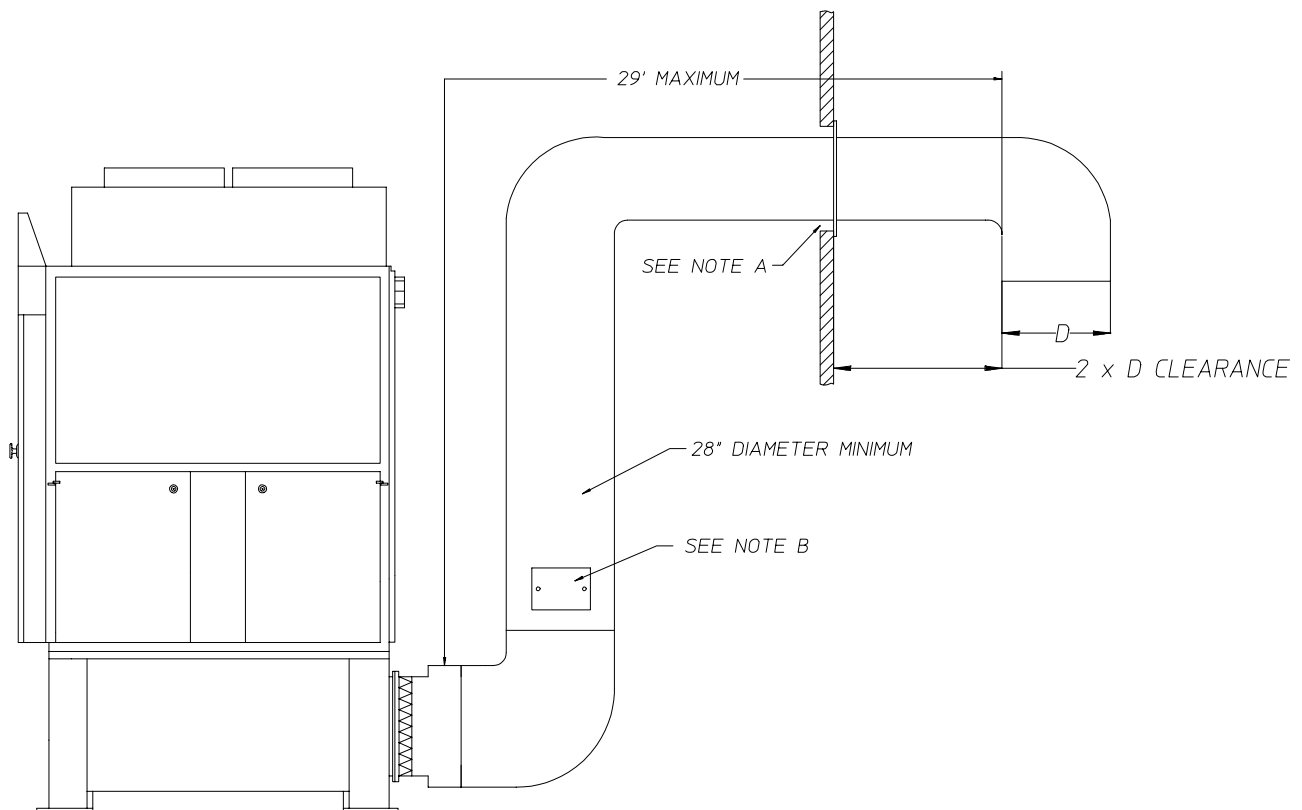

SIDE VIEW OF DRYER (SECTION VIEW) MAN1903

- NOTE: "A"- OPENING MUST BE TWO (2) INCHES LARGER THAN DUCT (ALL THE WAY AROUND). THE DUCT MUST BE CENTERED WITHIN THIS OPENING.
- "B"- INSPECTION DOORS SHOULD BE INSTALLED AT STRATEGIC POINTS FOR PERIODIC INSPECTION AND CLEANING

a. Outside Duct Work Protection

- 1) To protect the outside end of horizontal duct work from the weather, a 90° elbow bent downward **should be** installed where the exhaust exits the building. If the exhaust duct work travels vertically up through the roof, it **should be** protected from the weather by using a 180° turn to point the opening downward. In either case, allow at least twice the diameter of the duct between the duct opening and nearest obstruction.

IMPORTANT: *DO NOT* use screens, louvers, or caps on the outside of opening of exhaust duct work.

NOTE: Exhaust back pressure measured by a manometer at the dryer exhaust duct area **must not** exceed 0.3 inches of water column.

NOTE: Where the exhaust passes through a wall, ceiling, or roof made of combustible materials, the opening **must be** 2-inches larger (all the way around) than the duct. The duct **must be** centered within this opening.

VERTICAL DUCTING

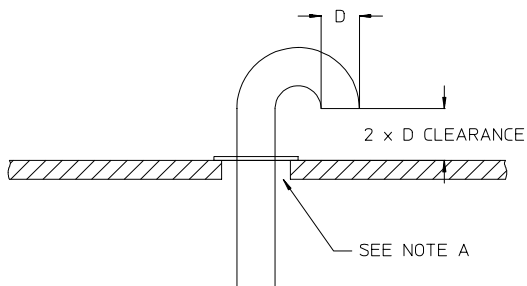

HORIZONTAL DUCTING

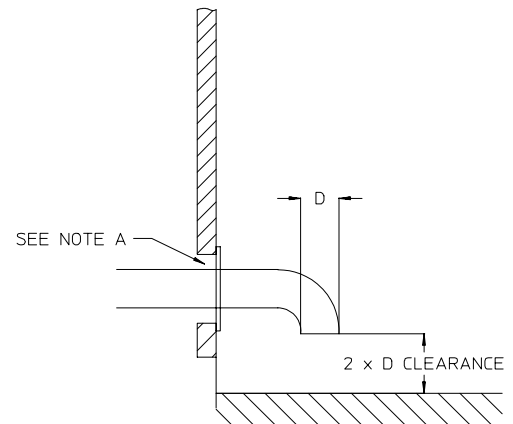

NOTE *A*: OPENING MUST BE TWO (2) INCHES LARGER THAN DUCT (ALL THE WAY AROUND). THE DUCT MUST BE CENTERED WITHIN THIS OPENING.

MAN0731

1. SINGLE DRYER VENTING

Where possible, it is suggested to provide a separate exhaust duct for each dryer. The exhaust duct **should be** laid out in such a way that the duct work travels as directly as possible to the outdoors with as few turns as possible. It is suggested that the use of 90° turns in ducting be avoided; use 30° and/or 45° angles instead. The shape of the exhaust duct work is not critical so long as the minimum cross section area is provided.

IMPORTANT: Minimum duct size for the dryer is 24-inches for a round duct or 22" x 22" for a square duct. Duct size **must not** be reduced anywhere downstream of the dryer.

IMPORTANT: Exhaust back pressure measured by a manometer at each basket (tumbler) exhaust duct area **should not** exceed 0.3 inches of water column.

It is suggested that the duct work from each dryer not exceed (30) feet with no more than two (2) elbows (excluding dryer connections and outside exhaust outlets). If the duct work exceeds thirty (30) feet or has numerous elbows, the cross section area of the duct work must be increased in proportion to the length and number of elbows in it. In calculating duct size, the cross section area of a square or rectangular duct must be increased by twenty (20) percent for each additional twenty (20) feet. The diameter of a round exhaust duct should be increased ten (10) percent for each additional fifteen (15) feet. Each 90° elbow is equivalent to an additional forty-five (45) feet, and each 45° elbow is equivalent to an additional twenty-three (23) feet.

SINGLE DRYER VENTING

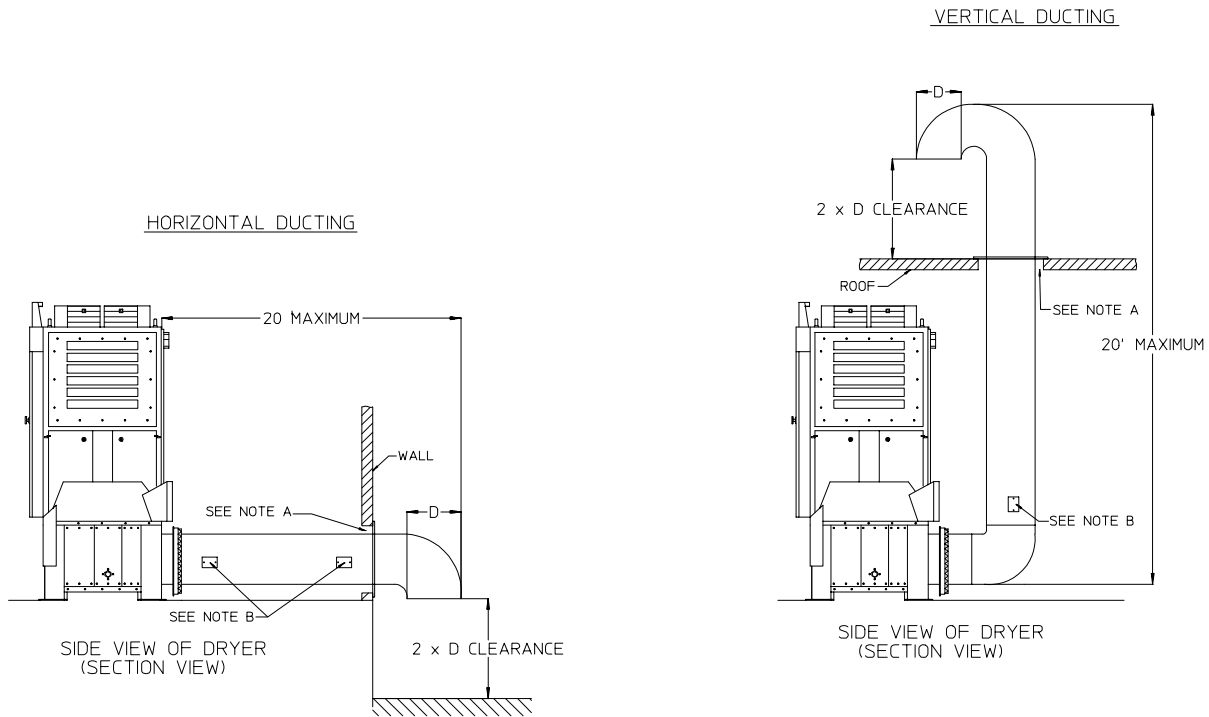

NOTE: "A"- OPENING MUST BE TWO (2) INCHES LARGER THAN DUCT (ALL THE WAY AROUND). THE DUCT MUST BE CENTERED WITHIN THIS OPENING.
 "B"- INSPECTION DOORS SHOULD BE INSTALLED AT STRATEGIC POINTS FOR PERIODIC INSPECTION AND CLEANING

MAN2621

IMPORTANT: For extended duct work runs, the cross section area of the duct can only be increased to an extent. Maximum proportional duct work runs **cannot** exceed twenty (20) feet more than the original limitations of thirty (30) feet with two (2) elbows. When the duct work approaches the maximum limits as noted in this manual, a professional heating venting air conditioning (HVAC) firm **should be** consulted for proper venting information.

ALL duct work **should be** smooth inside with no projections from sheet metal screws or other obstructions which will collect lint. When adding ducts, the duct to be added should overlap the duct to which it is to be connected. **ALL** duct work joints **must be** taped to prevent moisture and lint from escaping into the building. Inspection doors **should be** installed at strategic points in the exhaust duct work for periodic inspection and clean-out of lint from the duct work.

NOTE: Where the exhaust duct passes through a wall, ceiling, or roof made of combustible materials, the opening **must be** 2-inches larger (all the way around) than the duct. The duct **must be** centered within this opening.

a. Outside Duct Work Protection

- 1) To protect the outside end of horizontal duct work from the weather, a 90° elbow bent downward **should be** installed where the exhaust exits the building. If the exhaust duct work travels vertically up through the roof, it **should be** protected from the weather by using a 180° turn to point the opening downward. In either case, allow at least twice the diameter of the duct between the duct opening and nearest obstruction.

IMPORTANT: **DO NOT** use screens, louvers, or caps on the outside of opening of exhaust duct work.

E. COMPRESSED AIR SUPPLY SYSTEM

The compressed air system of the AD-310 Tilting dryer consists of a number of pneumatic pistons located throughout the dryer. The pistons are actuated by solenoid and flow control valves that are under computer control. The pneumatic pistons are used to:

- Tilt the Dryer For Loading and Unloading.
- Open and Close The Load and Unload Doors
(for AD-310 dryer models equipped with Automatic Doors).
- Operate The Steam Coil Damper (for ADS-310 Steam Heated Models ONLY).

1. Filter / Regulator / Gauge Assembly

The compressed air supply to the dryer is connected into the 3/8" F.P.T. fitting of the filter/regulator/gauge (F/R/G) assembly which is located at the bottom rear of the right side of the base.

The F/R/G assembly performs three (3) essential functions. The filter removes most solids and liquid particles from the compressed air stream and traps them in its bowl where this waste can be readily removed through the drain valve at the bottom of the bowl.

The filter bowl should be cleaned monthly.

The regulator will maintain a nearly constant outlet air pressure so that the dryer's air pistons will function normally despite upstream air pressure variations. After the compressed air is connected into the F/R/G assembly, adjust the regulator knob so that the gauge needle reads 80 psi.

2. Tilting-Piston Solenoid Valves

A two-way-tilt dryer has two (2) of these solenoid valves...one to control the front set of tilting pistons and a second to control the rear set of tilting pistons. A one-way-tilt dryer has only one (1) solenoid valve.

Each valve has five (5) 3/8" F.P.T. ports and two (2) electric solenoid operators, one on each side of the valve.

To tilt the dryer forward, a 24 volt signal is applied to the rear pistons solenoid connector "12" and no voltage is applied to the solenoid connector "14". The internal spool in the valve will move and 80 psi of air will enter the bottom port of the rear tilting pistons, extending the rear tilting piston rods and tilting the dryer forward for unloading. The top piston ports are bled to the atmosphere.

To level the dryer, the voltage signals are reversed. No voltage is applied to the "12" solenoid, and 24 volts is applied to the "14" solenoid. The valve spool will now move so that 80 psi of air is applied at the top piston ports, while the bottom piston ports are bled to the atmosphere. The piston rod will now retract, leveling the dryer. On rear tilt dryers, the front tilting piston solenoid valve acts in the same manner.

The tilting piston valves are 5 port / 3 piston valves. If no voltage is applied to both the "12" and "14" solenoids, all five (5) valve ports are blocked. This means that, if the dryer is tilting or leveling and power to the dryer is shut off, the pistons will lock in position, holding the dryer in a partially tilted position.

The dryer can be made to tilt faster or slower by adjusting the tilting pistons 3/8" flow control valves which are located on the pneumatic control panel.

The tilting piston valves and flow control valves are located on the pneumatic plate in the rear of the dryers' base.

3. Internal / External Pilot Air Supply

On two-way-tilt dryers, a pneumatic safety circuit is incorporated to prevent both front and rear tilting pistons from extending their rods at the same time. When 24 volts is supplied to the "12" side of the front tilting piston solenoid valve coil, the round internal spool in the core of the solenoid will move, allowing 80 psi air to flow into the bottom ports of the front tilting pistons, while the top ports are bled to the atmosphere. In addition to this 24 volt electrical signal, the spool also requires a 30 psi supply of compressed air to change its position. This pilot air can either be supplied internally, tapped off the 80 psi air supply connected to port no. 1 through holes in the body of the solenoid valve or it can be supplied externally through the 1/8" F.P.T. connection located on either end of the solenoid valve. If no pilot air is supplied to the solenoid valve, then the spool **cannot** move, even with voltage supplied to the solenoid valve.

This can be used to prevent both sets of tilting options from extending their rods at the same time. When the front tilting piston rods are extended, 80 psi air is connected to the bottom piston ports, while the top piston ports are bled to the atmosphere. So, by tapping the external pilot air supply to the rear tilting piston solenoid valve off the air line to the front tilting piston top port, whenever the front tilting piston rods are extended, then there is no pilot pressure available to the rear tilting piston solenoid valve so that its spool **cannot** move and the rear tilting piston rods **cannot** extend even if a 24 volt signal is sent to its "12" side solenoid valve coil.

The external pilot air supply to the front tilting piston is tapped off of the rear tilting piston top port air line so that whenever the rear piston rods are extended, there is no pilot air supplied to the front tilting piston solenoid valve and the front tilting piston rods **cannot** extend. On the solenoid valve supplied on the dryer, the "12" side valve is externally piloted, while the "14" side valve is internally piloted.

A valve can easily be checked for internal or external piloting by removing the two (2) screws which hold the solenoid operator onto the valve. For an internal pilot, the "o" ring **should be** positioned over the internal pilot supply port. This allows internal pilot air to be supplied to the valve spool. For external pilot, the solid sealing disc **must be** positioned on top of the internal port.

4. OPTIONAL Automatic (Piston Operated) Load / Unload Doors

If the dryer is equipped with the Automatic Door OPTION then the loading doors are operated by two (2) pneumatic pistons located above the load doors. On two (2) door dryers, the unloading doors on the back of the dryer will also be controlled by two (2) pistons, located above the unload doors.

The 24 volt solenoid valve operators controlling the door pistons are located on the pneumatic plate in the rear of the dryer's base. These solenoid valves are configured so that if power to the dryer is shut off, the door piston's ports are bled to the atmosphere so that the doors can be opened and closed by hand.

5. OPTIONAL Sprinkler Valve

The sprinkler water flow is controlled by a pneumatically operated water valve, which is located in the left side of the base. This water valve is controlled by a 3 port/2 position, 24 volt - double solenoid valve which is located at the top of the dryer's pneumatic plate. If no voltage is applied to both solenoids then all three (3) ports are blocked. This means that if the sprinkler is activated and power to the dryer is then shut off, the sprinkler will stay on, until the manual water valve is closed or until the dryer's internal temperature drops below the sprinkler set point temperature and the sprinkler reset button is physically pushed.

F. ELECTRICAL INFORMATION

1. Electrical Requirements

It is your responsibility to have **ALL** electrical connections made by a properly licensed and competent electrician to assure that the electrical installation is adequate and conforms with local and state regulations or codes. In the absence of such codes, **ALL** electric connections, materials, and workmanship **must conform** to the applicable requirements of the National Electric Code ANSI/NFPA NO. 70-LATEST EDITION.

IMPORTANT: Failure to comply with these codes or ordinances, and/or the requirements stipulated in this manual can result in personal injury or component failure.

NOTE: Component failure due to improper installation **VOIDS THE WARRANTY.**

Each dryer **should be** connected to an independently protected branch circuit. The dryer **must be** connected with copper wire **ONLY**. **DO NOT use aluminum wire which could cause a fire hazard.** The copper conductor wire/cable **must be** of proper ampacity and insulation in accordance with electric codes for making **ALL** service connections.

NOTE: The use of aluminum wire will **VOID THE WARRANTY.**

The electrical input power connections are made into the base electrical junction box located in the right front portion of the dryer's base.

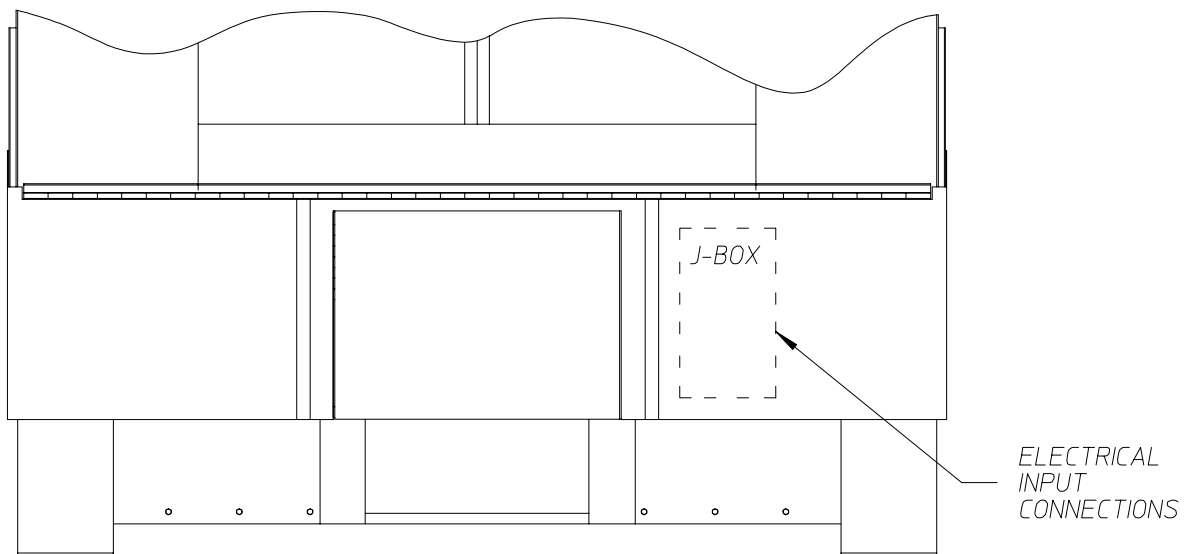

FRONT VIEW OF
AD - 310 BASE

MAN2779

1. Electrical Service Specifications

AD-310
Gas 15 HP Blower Motor / 5 HP Drive Motor
Steam 25 HP Blower Motor / 5 HP Drive Motor

IMPORTANT: 208 VAC and 230/240 VAC are not the same. When ordering, specify exact voltage.

- NOTES:** A. Fuse ratings are dual element-time delay-current limiting, class RK1 or RK5 **ONLY**.
 B. Circuit breakers are thermal magnetic (industrial) type **ONLY**. For others, calculate/verify correct breaker size according to appliance amp draw rating and type of breaker used.
 C. Circuit breakers for 3 dryers **must be** 3-pole type.

SERVICE VOLTAGE	PHASE WIRE SERVICE		APPROX. AMP DRAW		MINIMUM WIRE SIZE*		FUSING		CIRCUIT BREAKER	
			Gas	Steam	Gas	Steam	Dual Element Time Delay		Gas	Steam
							Gas	Steam		
208	3Ø	3/4	56	80	#4	#3	80	100	90	110
230	3Ø	3/4	51	71	#6	#3	80	100	90	110
380	3Ø	3/4	31	44	#8	#6	50	60	60	90
416	3Ø	3/4	29	40	#8	#6	50	60	60	80
460/480	3Ø	3/4	27	37	#8	#6	50	60	60	80

IMPORTANT: THE DRYER MUST BE CONNECTED TO THE ELECTRIC SUPPLY SHOWN ON THE DATA LABEL THAT IS AFFIXED TO THE BACK PANEL OF THE MAIN ELECTRICAL CABINET.

WARNING: 208 VAC and 230/240 VAC ARE NOT THE SAME. Any damage done to dryer components due to improper voltage connections will automatically VOID THE WARRANTY.

NOTE: ADC reserves the right to make any changes in specifications at any time, without notice or obligation.

3. Electrical Connections

NOTE: A wiring diagram is included with each dryer and is located in the blueprint pocket inside the left side control cabinet.

The main electrical input connections to the dryer are the 3-phase (3Ø) power leads (L1, L2, and L3), GROUND, and in the case of 4 wire service, the Neutral. These electrical connections are made at the power distribution block located in the base front electrical enclosure.

If the dryer has an optional sprinkler circuit then a separate single-phase (1Ø) source **must be** supplied to the sprinkler circuit at the name plate voltage. These connections are made at the power distribution block located in the base front electrical enclosure.

The main electrical (3-phase [3Ø]) connections (L1, L2, and L3) and the optional (single-phase [1]) connection **must be** provided and installed in accordance with state and local codes. In the absence of these codes, grounding **must conform** to applicable requirements of the National Electric Code ANSI/NFPA NO. 70-LATEST EDITION. In ALL cases, a strain relief must be used where the wire(s) enter the dryer electrical service (relay) box.

NOTE: A CIRCUIT SERVING EACH DRYER MUST BE PROVIDED.

4. Main Grounding

Grounding (earth) connections **must be** provided and installed in accordance with state and local codes. In the absence of these codes, grounding **must conform** to applicable requirements of the National Electric Code ANSI/NFPA NO. 70-LATEST EDITION. The ground connection may be to a proven earth ground at the location service panel.

NOTE: A grounding connection (terminal lug) is provided in the dryer in the Base Electrical Junction Box.

For added personal safety, when possible, it is suggested that a separate ground wire (sized per local codes) be connected from the ground connection of the dryer to a cold water pipe. **DO NOT** ground to a gas or hot water pipe. The grounded cold water pipe **must have** metal to metal connections all the way to electrical ground. If there are any nonmetallic interruptions, such as a meter, pump, plastic, rubber, or other insulating connectors, they **must be** jumped out with no. 4 copper wire and securely clamped to bare metal at both ends.

IMPORTANT: For personal safety and proper operation, the dryer **must be** grounded. For proper operation of the microprocessor (computer), an earth (zero) ground is required.

NOTE: Grounding via metallic electrical conduit (pipe) **is not** recommended.

G. GAS INFORMATION

It is your responsibility to have **ALL** plumbing connections made by a qualified professional to assure that the gas plumbing installation is adequate and conforms with local and state regulations or codes. In the absence of such codes, **ALL** plumbing connections, materials, and workmanship **must conform** to the applicable requirements of the National Fuel Gas Code ANSI Z223.1-LATEST EDITION.

IMPORTANT: Failure to comply with these codes or ordinances, and/or the requirements stipulated in this manual, can result in personal injury and improper operation of the dryer.

The dryer and its individual shut-off valves must be disconnected from the gas supply piping system during any pressure testing of that system at test pressures in excess of 1/2 psig (3.5 kPa). The dryer must be isolated from the gas supply piping system by closing its individual manual shut-off valve during any pressure test of the gas supply system at test pressures equal to or less than 1/2 psig (3.5 kPa).

IMPORTANT: Failure to isolate or disconnect dryer from supply as noted can cause irreparable damage to the gas valve **VOIDING THE WARRANTY**.

WARNING: FIRE or EXPLOSION COULD RESULT.

1. Gas Supply

The gas dryer installation **must meet** the American National Standard...National Fuel Gas Code ANSI Z223.1-LATEST EDITION, as well as local codes and ordinances and **must be** done by a qualified professional.

NOTE: Undersized gas piping will result in ignition problems, slow drying, increased use of energy, and can create a safety hazard.

The dryer **must be** connected to the type of heat/gas indicated on the dryer label affixed behind the right control box door. If this information does not agree with the type of gas available, **DO NOT operate the dryer**. Contact the distributor who sold the dryer or the **ADC** factory.

IMPORTANT: Any burner changes or conversions **must be** made by a qualified professional.

The input ratings shown on the dryer data label are for elevations up to 2,000 feet, unless elevation requirements over 2,000 feet were specified at the time the dryer order was placed with the factory. The adjustment or conversion of the dryers in the field for elevations over 2,000 feet are made by changing each burner orifice. If this conversion is necessary, contact the distributor who sold the dryer or contact the **ADC** factory.

2. Technical Gas Data

a. Gas Specifications

Type of Gas		
	Natural	Liquid Propane
Manifold Pressure*	3.5-4.0 inches W.C.	10.5 - 11.0 inches W.C.
Inline Pressure	6.0 to 12.0 inches W.C.	11.0 inches W.C.

* Measured at gas valve pressure taps when the gas valves are on.

b. Gas Connections:

Run a 1-1/2" pipe from the main gas header to the dryer. There is a 1-1/2" gas pipe connection at the bottom right side of the dryer's base.

Inlet connection ----- 1-1/2-inch N.P.T.

Btu/hr input (per dryer) ----- 1,125,000

1) Natural Gas

Pressure regulation is controlled by both gas valve's internal regulators. Incoming supply pressure **must be** consistent between a minimum of 6.0 inches water column (W.C.) and a maximum of 12.0 inches water column (W.C.).

2) Liquid Propane (L.P.) Gas

Dryers made for use with liquid propane (L.P.) gas have both of their gas valve's internal pressure regulators blocked open so that the gas pressure **must be** regulated upstream of the dryer. The pressure measured at each gas valve pressure tap must be a consistent 11.0 inches water column (W.C.). There is no regulator or regulation provided in an L.P. gas dryer. The water column **must be** regulated at the source (L.P. tank) or external regulator/regulation **must be** added to each dryer.

3. Piping/Connections

ALL components/materials **must conform** to National Fuel Gas Code Specifications. It is important that gas pressure regulators meet applicable pressure requirements and that gas meters be rated for the total amount of **ALL** the appliance BTU's being supplied.

The dryer is provided with a 1-1/2-inch N.P.T. inlet pipe connection located at the right side of the base of the dryer. For ease of servicing, the gas supply line of each dryer **must have** its own shut-off valve.

The size of the main gas supply line (header) will vary depending on the distance this line travels from the gas meter or, in the case of L.P. gas, the supply tank, other gas-operated appliances on the same supply line, etc. Specific information regarding supply line size **should be** determined by the gas supplier.

NOTE: Undersized gas supply piping can create a low or inconsistent pressure which will result in erratic operation of the burner ignition system.

TYPICAL NATURAL GAS INSTALLATION

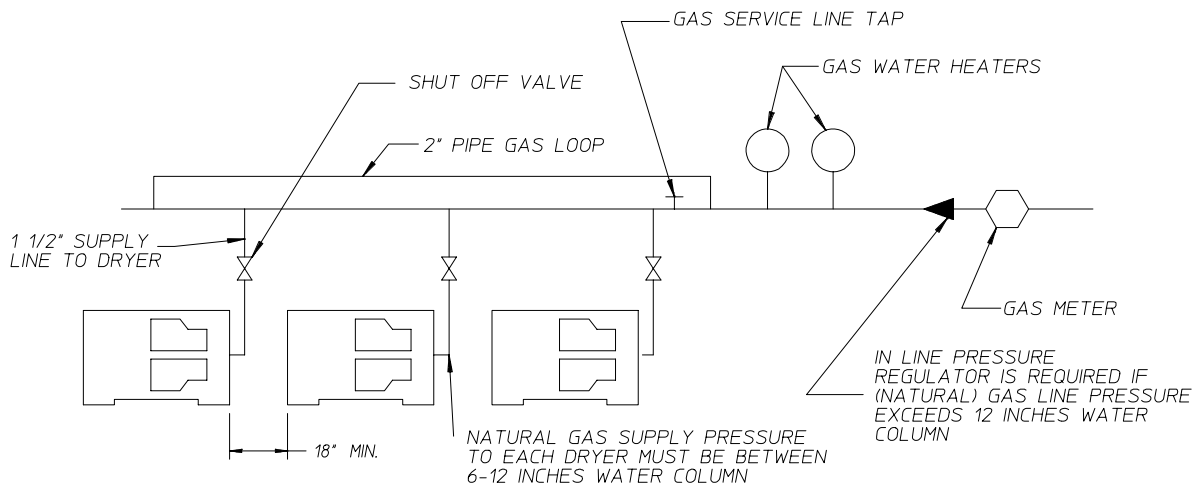

TYPICAL L.P. GAS INSTALLATION

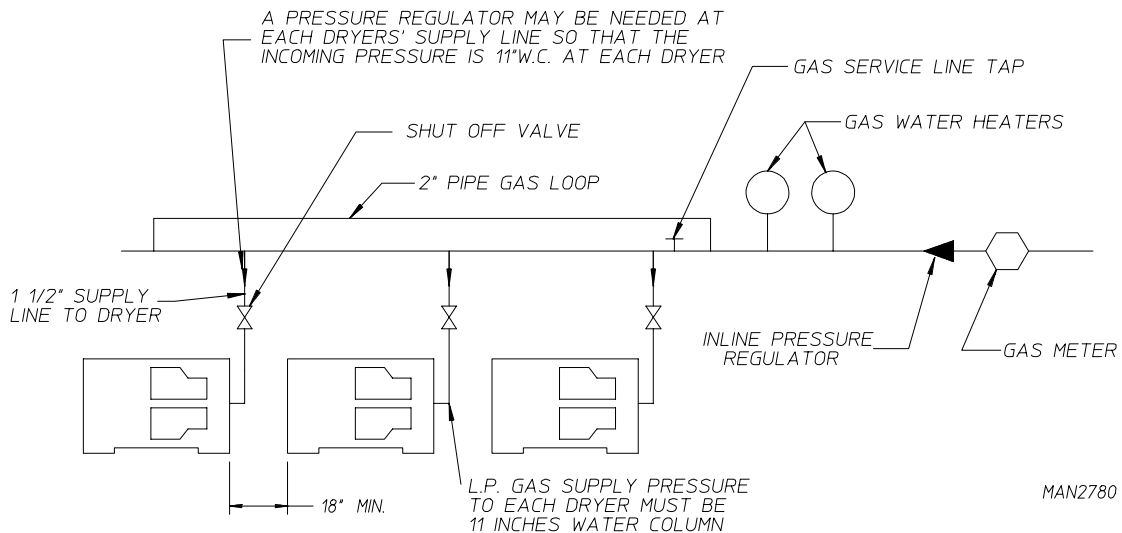

MAN2780

Consistent gas pressure is essential at **ALL** gas connections. It is recommended that a 2-inch pipe gas loop be installed in the supply line serving a bank of dryers. An in-line pressure regulator **must be** installed in the gas supply line (header) if the (natural) gas pressure exceeds 12.0 inches of water column pressure.

IMPORTANT: A water column pressure of 4.0 inches for natural gas and 11.0 inches for L.P. dryers is required at the gas valve pressure tap of each dryer for proper and safe operation.

A 1/8-inch N.P.T. plugged tap, accessible for a test gauge connection, **must be** installed in the main gas supply line immediately upstream of each dryer.

IMPORTANT: Pipe joint compounds that resist the action of natural and L.P. gases **must be** used.

IMPORTANT: Test **ALL** connections for leaks by brushing on a soapy water solution (liquid detergent works well).

WARNING: NEVER TEST FOR GAS LEAKS WITH A FLAME!!!

ALL components/materials **must conform** to National Fuel Gas Code Specifications ANSI Z223.1-LATEST EDITION. It is important that gas pressure regulators meet applicable pressure requirements, and that gas meters be rated for the total amount of **ALL** the appliance BTU's being supplied.

IMPORTANT: The dryer and its individual shut-off valve **must be** disconnected from the gas supply piping system during any pressure testing of that system at test pressures in excess of 1/2 psig (3.5kPa).

NOTE: The dryer **must be** isolated from the gas supply piping system by closing its individual manual shut-off valve during any pressure testing of the gas supply piping system at test pressures equal to or less than 1/2 psig (3.5kPa).

H. STEAM INFORMATION

It is your responsibility to have **ALL** steam plumbing connections made by a qualified professional to assure that the installation is adequate and conforms with local and state regulations or codes.

IMPORTANT: Failure to comply with the requirements stipulated in this manual can result in component failure which will VOID THE WARRANTY.

NOTE: The ADS-310 is manufactured with a pneumatic (piston) damper system which requires an external supply of clean, dry, regulated air (80 psi +/- 10 psi).

1. STEAM COIL PH LEVEL

The normal PH level for copper type steam coils must be maintained between a value of 8.5 to 9.5. For steel type steam coils the PH level must be maintained between a value of 9.5 to 10.5. These limits are set to limit the acid attack of the steam coils.

IMPORTANT: Coil failure due to improper PH level will VOID THE WARRANTY.

2. STEAM REQUIREMENTS - High Pressure

Inlet ----- 2" supply line connection
Return ----- 1-1/4" return line connection

Operating Steam Pressure -- High Pressure		
Maximum	125 psig	8.79 kg/sq cm
Minimum	100 psig	7.03 kg/sq cm
Heat Input (Normal Load)	35 Bhp	
Consumption (approximate)	890 lbs/hr	404.5 kg/hr

Shaded areas are in metric equivalents.

3. INSTALLATION INSTRUCTIONS

To insure that an adequate supply of steam is provided, be sure that the steam supply and steam return lines are sized and laid out as stipulated in this manual. Inadequate steam supply and steam return lines or improper steam plumbing will result in poor performance and can cause component failure. Clean, dry, regulated steam **must be** provided to the dryer.

IMPORTANT: Steam coil failure due to water hammer by wet steam will ...
VOID THE WARRANTY.

- a. The presence of the condensate in the steam supply will cause water hammer and subsequent heat exchanger (steam coil) failure. The steam supply connection into the main supply line **must be** made with a minimum 10-inch riser. This will prevent any condensate from draining towards the dryer.
- b. The steam supply piping to the dryer **must include** a 12-inch rise along with a drip trap and check valve. This will prevent any condensate from entering the steam coil.
- c. Flexible hoses or couplings **must be** used. The dryer vibrates slightly when it runs and this will cause the steam coil connections to crack if they are hard piped to the supply and return mains.
- d. Shut-off valves for each dryer **should be** installed in the supply, return, and drip trap return lines. This will allow the dryer to be isolated from the supply and return mains if the dryer needs maintenance work.
- e. Install an inverted bucket steam trap and check valve for each unit at least 12-inches below steam coil as close to the coil as possible.
- f. The supply and return lines **should be** insulated. This will save energy and provide for safety of the operator and maintenance personnel.
- g. Water pockets in the supply line, caused by low points, will provide wet steam to the coil possibly causing coil damage. **ALL** horizontal runs of steam supply piping **should be** pitched 1/4-inch for every one (1) foot back towards the steam supply header causing any condensate in the line to drain to the header. Install a bypass trap in any low point to eliminate wet steam.

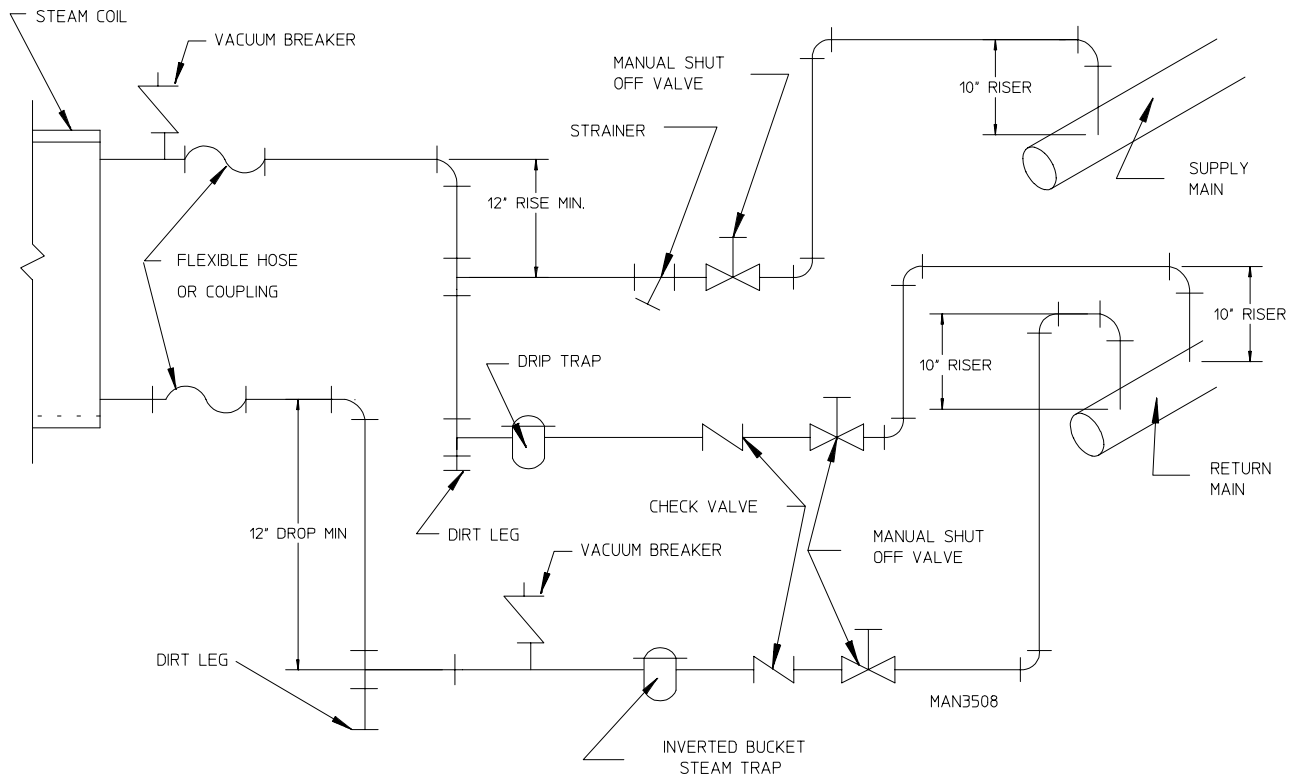

4. STEAM DAMPER AIR SYSTEM CONNECTIONS

The ADS-310 is manufactured with a pneumatic (piston) damper system which requires an external supply of compressed air. The air connection is made at the left hand side on top of the dryer.

a. Air Requirements

Compressed Air Supply	Air Pressure
Normal	80 PSI
Minimum Supply	70 PSI
Maximum Supply	90 PSI

b. Air Connection

Air connection to system --- 1/8-inch F.P.T.

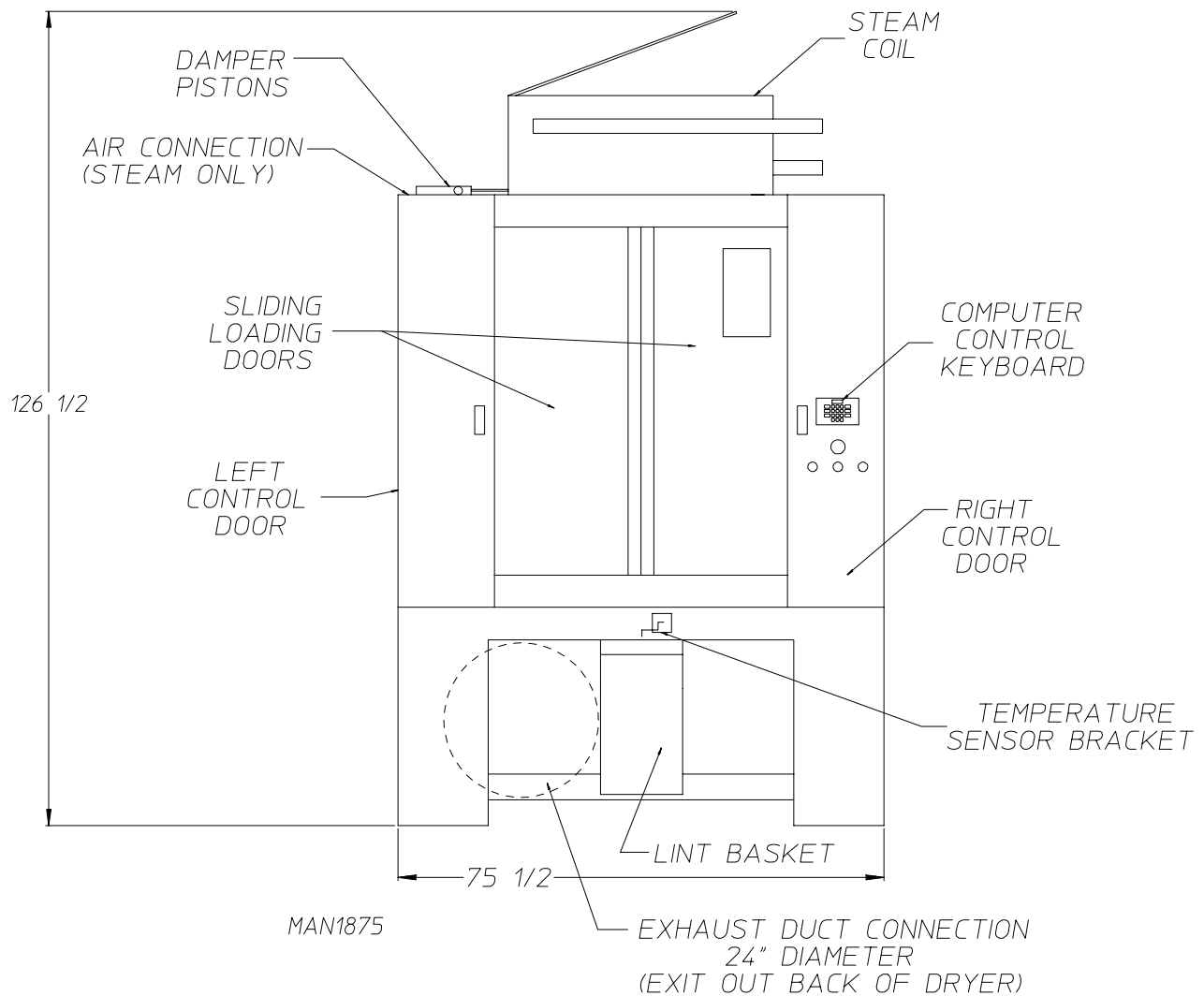

c. No air regulation or filtration is provided with the dryer. External regulation/filtration of 80 psi **must be** provided. It is suggested that a regulator/filter gauge arrangement be added to the compressed air line just before the dryer connection. This is necessary to insure that correct and clean air pressure is achieved.

5. STEAM DAMPER SYSTEM OPERATION

The ADS-310 steam damper, as shown in the **illustration below**, allows the coil to stay constantly charged eliminating repeated expansion and contraction. When the damper is opened, the air immediately passes through the already hot coil, providing instant heat to start the drying process. When the damper is closed, ambient air is drawn directly into the basket (tumbler), allowing a rapid cool down.

Diagram 1 --shows the damper in the heating (open) mode, allowing heat into the basket (tumbler).

Diagram 2 --shows the damper in the cool down (closed) mode, pulling ambient air directly into the basket (tumbler) without passing through the coils.

NOTE: With the dryer off or with no air supply, the damper is in the cool down mode as shown in **Diagram 2**.

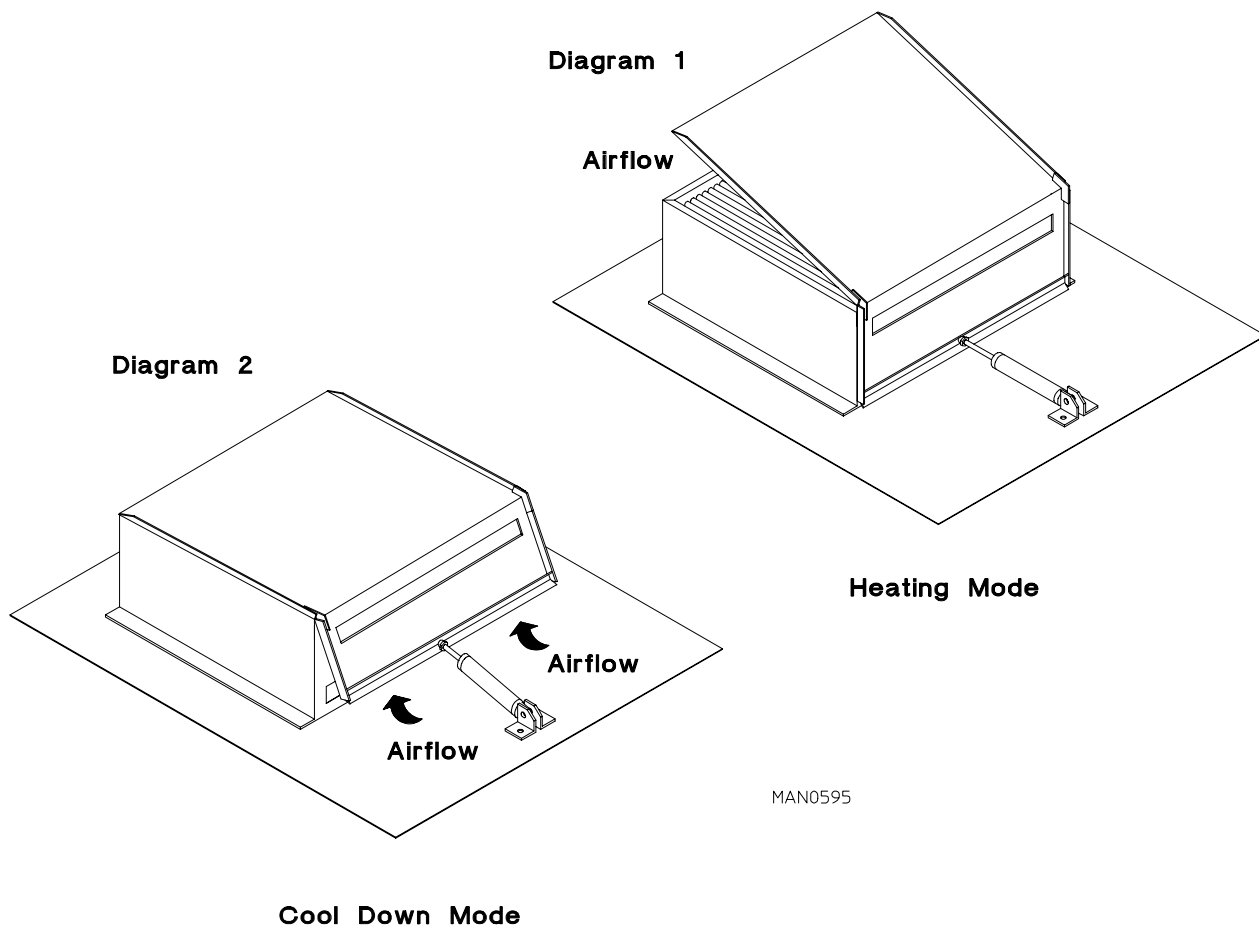

MAN0595

6. STEAM DAMPER AIR PISTON (Flow Control) OPERATION ADJUSTMENT

Steam damper operation was tested and adjusted prior to shipping at 80 PSI. If steam damper adjustment is necessary, locate the flow control valve and make the necessary adjustments as noted below.

NOTE: Adjust both flow control valves equally, so that both pistons operate at the same time.

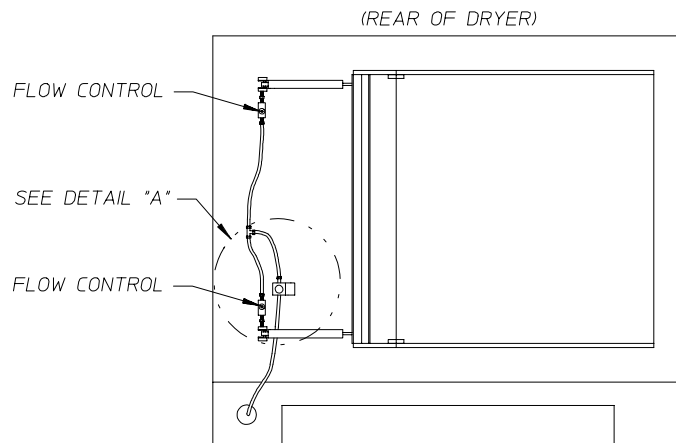

NOTE:
TURNING KNOB ON FLOW CONTROL CLOCKWISE WILL RESTRICT AIR FLOW. TURNING KNOB COUNTER-CLOCKWISE WILL ALLOW HIGHER AIR FLOW.

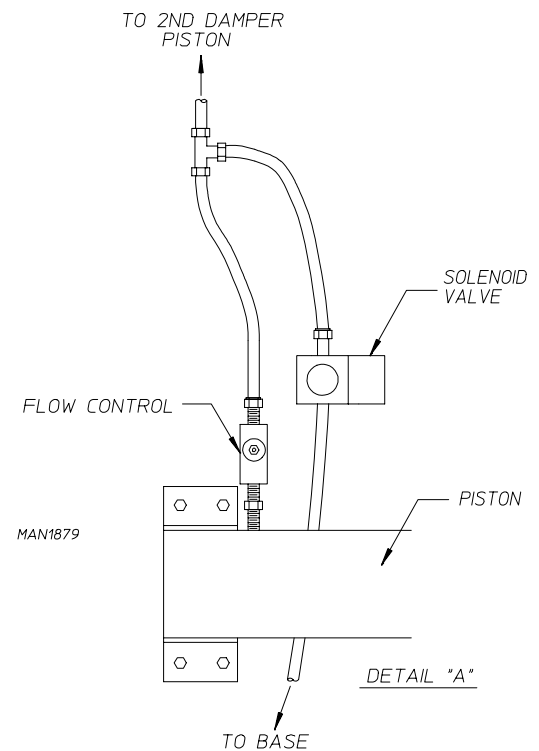
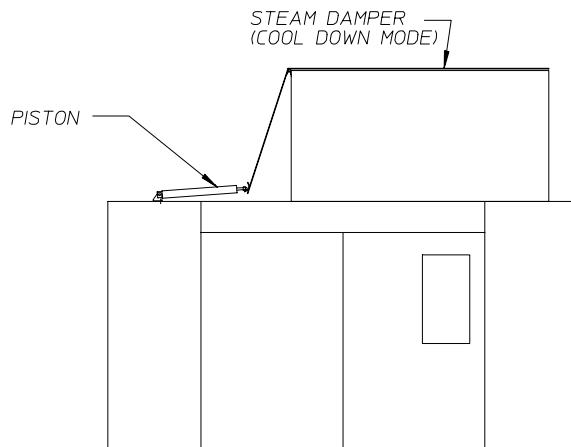

I. WATER SUPPLY CONNECTION FOR OPTIONAL SPRINKLER SYSTEM

If the dryer is equipped with the optional sprinkler system, a water supply of approximately 40 psi; must be connected into the 1" N.P.T. sprinkler shut-off valve located on the left side of the dryer's base.

J. PREOPERATIONAL TESTS

ALL dryers are thoroughly tested and inspected before leaving the factory. However, a preoperational test **should be** performed before the dryer is publicly used. It is possible that adjustments have changed in transit or due to marginal location (installation) conditions.

1. Turn on electric power to the dryer.
2. Make sure loading doors are closed and the lint drawer is closed.
3. Microprocessor (computer) system operational test -- to start the dryer;
 - a. Display will read "FILL."
 - b. Press "E" (preprogrammed) cycle key on the touch pad of the keyboard.
 - c. Display will quickly read..."Ld30", "Lc04", and "F180" (unless special programs requested). These codes mean that the dryer is in the timed mode and will operate with heat of 180° F (Fahrenheit) for 30 minutes drying time and have a 4 minute cool down period.
 - d. Dryer will now start, and the L.E.D. display will read "Dr30" (dry mode for 30 minutes) and count downwards in minutes.

NOTE: Dryer can be stopped at any time by opening the main door or by pressing the "CLEAR/STOP" key. To restart the dryer, press the "ENTER/START" key or a preprogrammed cycle key (i.e., "E").

NOTE: Pressing touch pad key "A", "B", "C", "D", and "F" will also start the dryer. The six preprogrammed drying cycles ("A" thru "F") have been stored in the microprocessor (computer's) memory. Refer to the Programming Manual supplied with the dryer for these preprogrammed cycles.

4. Check to insure that the tumbler (basket) starts in the clockwise (CW) direction. Additionally, check the direction of the blower motor to insure that it rotates in the counterclockwise (CCW) direction as viewed from the left side of the dryer. If it does, the phasing is correct. If the phasing is incorrect, reverse two (2) of the leads at L1, L2, or L3 of the power supply connections made to the dryer.

IMPORTANT: Dryer blower motor and impellor/fan shaft as viewed from the left side of the dryer **must turn** in the counterclockwise (CCW) direction, otherwise the dryer efficiency will be drastically reduced, and premature component failure can result.

5. Heat Circuit Operational Test

a. Gas Models

1. When the dryer is first started (during initial start-up), the burners have a tendency not to ignite on the first attempt. This is because the gas supply piping is filled with air, so the dryer may have to be stopped and restarted several times for this air to be purged from the lines.

2. The dryer has two (2) burner boxes and each burner box has its own Direct Spark Ignition (DSI) Module and Spark Ignition/Flame-Probe Assembly. If ignition is not established after the first attempt, the heat circuit DSI Module will *lock out* until it is manually reset. To reset the DSI system, open and close the loading doors and restart the dryer (press the "ENTER/START" key).

If one burner lights and the other does not, then the system will shut both burners off and the "**HEATER FAULT LIGHT**" on the right front control door will light up.

NOTE: During the purging period, verify that ALL gas shut-off valves are open.

3. Once ignition is established, a gas pressure test **should be** taken at each gas valve pressure tap of the dryer to assure that the water column pressure is correct and consistent.

NOTE: Water column pressure requirements (measured at both gas valve pressure taps)...

NATURAL GAS ----- 4.0 INCHES W.C.
L.P. GAS ----- 11.0 INCHES W.C.

IMPORTANT: There is no regulator provided in an L.P. dryer. The water column (W.C.) pressure **must be** regulated at the source (L.P. tank), or an external regulator **must be** added to each dryer.

b. Steam Models

- 1) Check to insure that the steam damper is functioning properly.

6. Make a complete operational check of ALL safety-related circuits (i.e., lint drawer switch and sail switches on Gas Models).
7. A reversing tumbler **should never be** operated with less than a 100-pound load (dry weight). The size of the load will affect the coast-down and dwell (stop) times. The tumbler must come to a complete stop before starting in the opposite direction. For automatic (mode) cycle only, the spin and stop times **are not** adjustable and have been preprogrammed into the microprocessor controller (computer) for a 2-minute spin time and a 5-second dwell (stop) time).

IMPORTANT: The dryer tumbler (basket) is treated with a protective coating. **ADC** suggests tumbling old clothes or material in the tumbler (basket) using a mild detergent to remove the protective coating.

8. Each dryer **should be** operated through one (1) complete cycle to assure that no further adjustments are necessary and that ALL components are functioning properly.
9. Microprocessor (computer) programs/selections...
 - a. Each microprocessor controller (computer) has been preprogrammed by the factory with the most commonly used parameter selections. If computer program changes are required, refer to the Computer Programming Manual which was shipped with the dryer.

K. PREPARATION FOR OPERATION / START-UP

The following items **should be** checked before attempting to operate the dryer:

1. Read **ALL** "CAUTION," "WARNING," and "DIRECTION" labels attached to the dryer.
2. Check incoming supply voltage to be sure that it is the same as indicated on the dryer data label affixed behind the right control box door. In the case of 208 VAC or 230/240 VAC, for dryers with sprinkler option, verify 1Ø voltage is correct. The supply voltage **must match** the electric service **exactly**.
3. **GAS MODELS** - check to assure that the dryer is connected to the type of heat/gas indicated on the dryer data label.
4. **GAS MODELS** - the sail switch damper assembly was installed and adjusted at the factory prior to shipping. However, each sail switch adjustment **must be** checked to assure that this important safety control is functioning.
5. **GAS MODELS** - be sure that **ALL** gas shut-off valves are in the open position.
6. Be sure **ALL** side and base panels are on the dryer.
7. Check **ALL** service doors to assure that they are closed and secure.
8. Be sure lint drawer is securely in place.

NOTE: LINT DRAWER MUST BE ALL THE WAY IN PLACE TO ACTIVATE SAFETY SWITCH OTHERWISE THE DRYER WILL NOT START.

9. Rotate the basket (tumbler/drum) by hand to be sure it moves freely.
10. Check bolts, nuts, screws, terminals, and fittings for security.
11. Check to insure air supply (80 psi) is connected to the dryer.
12. **STEAM MODELS** - check to insure **ALL** steam shut-off valves are open.

L. SHUT DOWN INSTRUCTIONS

If the dryer is to be shut down (taken out of service) for a period of time, the following **MUST BE** performed;

1. Discontinue power to the dryer either at the external disconnect switch or the circuit breaker.
2. Discontinue the heat supply:
 - a. **GAS MODELS** ... discontinue the gas supply.
 - 1) **SHUT OFF** external gas supply shut-off valve.
 - 2) **SHUT OFF** internal gas supply shut-off valve located in the gas valve burner area.
 - b. **STEAM MODELS** ... discontinue steam supply.
 - 1) **SHUT OFF** external (location furnished) shut-off valve.
 - 2) **SHUT OFF** internal steam valves in the supply lines and the return lines.

SECTION IV

SERVICE/PARTS INFORMATION

A. SERVICE

1. Service **must be** performed by a qualified trained technician, service agency, or gas supplier. If service is required, contact the distributor from whom the **ADC** equipment was purchased. If the distributor cannot be contacted or is unknown, contact the **ADC** Service Department for a distributor in your area.

NOTE: When contacting the **ADC** Service Department, be sure to give them the correct **model number** and **serial number** so that your inquiry is handled in an expeditious manner.

B. PARTS

1. Replacement parts **should be** purchased from the distributor from whom the **ADC** equipment was purchased. If the distributor **cannot** be contacted or is unknown, contact the **ADC** Parts Department for a distributor in your area. Parts may also be purchased directly from the factory by calling the **ADC** Parts Department at (508) 678-9010 or you may FAX in your order at (508) 678-9447.

NOTE: When ordering replacement parts from the **ADC** dealer or the **ADC** factory be sure to give them the correct **model number** and **serial number** so that your parts order can be processed in an expeditious manner.

SECTION V

WARRANTY INFORMATION

A. RETURNING WARRANTY CARD(S)

1. Before any dryer leaves the **ADC** factory test area, a warranty card (**ADC** Part No. 112254) is placed on the back side of the main door glass. These warranty cards are intended to serve the customer where we record the individual installation date and warranty information to better serve you should you file a warranty claim.
 - a. If a warranty card (**ADC** Part No. 112254) did not come with your dryer, contact the **ADC** Warranty Department or **ADC** Service Department at (508) 678-9000.

IMPORTANT: A separate warranty card **must be** completed and returned for each individual dryer.

NOTE: Be sure to include the installation date when returning the warranty card(s).

B. WARRANTY

For a copy of the **ADC** commercial warranty covering your particular dryer(s), contact the **ADC** distributor from whom you purchased the equipment and request dryer warranty form **ADC** Part No. 450199. If the distributor **cannot** be contacted or is unknown, warranty information can be obtained from the factory by contacting the **ADC** Warranty Department at (508) 678-9000.

NOTE: Whenever contacting the **ADC** factory for warranty or warranty information, be sure to have the dryer's **model number** and **serial number** available so that your inquiry can be handled in an expeditious manner.

C. RETURNING WARRANTY PARTS

ALL dryer or parts warranty claims or inquiries **should be** addressed to the **ADC** Warranty Parts Department. To expedite processing, the following procedures **must be** followed:

1. No parts are to be returned to **ADC** without prior written authorization ("Return Material Authorization") from the factory.

NOTE: An R.M.A. ("Return Material Authorization") is valid for only sixty (60) days from date of issue.

- a. The R.M.A. issued by the factory, as well as any other correspondence pertaining to the returned part(s), **must be** included inside the package with the failed merchandise.

2. Each part **must be** tagged with the following information:
 - a. **Model number** and **serial number** of the dryer from which part was removed.
 - b. Nature of failure (be specific).
 - c. Date of dryer installation.
 - d. Date of part failure.
 - e. Specify whether the part(s) being returned is for a replacement, a credit, or a refund.

NOTE: If a part is marked for a credit or a refund, the invoice number covering the purchase of the replacement part **must be** provided.

NOTE: Warranty tags (ADC Part No. 450064) are available at "no charge" from ADC upon request.

3. The company returning the part(s) must clearly note the complete company name and address on the outside of the package.
4. **ALL** returns **must be** properly packaged to insure that they are not damaged in transit. *Damage claims are the responsibility of the shipper.*

IMPORTANT: No replacements, credits or refunds will be issued for merchandise damaged in transit.

5. **ALL** returns **should be** shipped to the ADC factory in such a manner that they are insured and a proof of delivery can be obtained by the sender.
6. **Shipping charges are not the responsibility of ADC. ALL returns should be "prepaid" to the factory. Any "C.O.D." or "COLLECT" returns will not be accepted.**

IMPORTANT: **No** replacements, credits, or refunds will be issued if the claim *cannot* be processed due to insufficient information. The party filing the claim will be notified in writing, either by "FAX" or "CERTIFIED MAIL - Return Receipt Requested", as to the information necessary to process claim. If a reply is not received by the ADC Warranty Department within thirty (30) days from the FAX/letter date, then no replacement, credit, or refund will be issued, and the merchandise **will be** discarded.

SECTION VI

ROUTINE MAINTENANCE

A. CLEANING

A program and/or schedule **should be** established for periodic inspection, cleaning, and removal of lint from various areas of the dryer, as well as throughout the duct work system. The frequency of cleaning can best be determined from experience at each location. Maximum operating efficiency is dependent upon proper air circulation. The accumulation of lint can restrict this air flow. If the guidelines in this section are met, an ADC dryer will provide many years of efficient, trouble-free, and - most importantly - safe operation.

WARNING: LINT FROM MOST FABRICS IS HIGHLY COMBUSTIBLE. THE ACCUMULATION OF LINT CAN CREATE A POTENTIAL FIRE HAZARD.

WARNING: KEEP DRYER AREA CLEAR AND FREE FROM COMBUSTIBLE MATERIALS, GASOLINE, and OTHER FLAMMABLE VAPORS and LIQUIDS.

NOTE: Suggested time intervals shown are for average usage which is considered six (6) to eight (8) operational (running) hours per day.

CLEANING SCHEDULE

EVERY THIRD or FOURTH LOAD

Clean the lint basket. A clogged lint basket will cause poor dryer performance. The lint basket is located in the lint drawer in the base of the dryer. Pull out the lint drawer, brush the lint off the lint basket, and remove the lint. Inspect lint screen and replace if torn.

NOTE: Frequency can best be determined at each location.

WEEKLY

Open the hinged panels on each side of the tumbler section and remove any lint accumulation, from the tumbler drive motor, drive shafts, gear reducer, V-belts, drive wheels, and drive shaft bearings.

Slide the lint basket all the way out of the dryer and clean any lint accumulation off of the temperature sensor bracket, which is located above the lint basket.

WARNING: TO AVOID THE HAZARD OF ELECTRICAL SHOCK, DISCONTINUE ELECTRICAL SUPPLY TO THE DRYER.

MONTHLY

Empty the compressed air filter bowl.

EVERY 3 MONTHS

Re-grease the two (2) 1-3/8-inch bearings that support the impellor/fan shaft. Use Shell Alvania #3 grease or its equivalent. Impellor/fan shaft bearings must be lubricated.

Check to make sure that the set screws on the impellor/fan shaft bearing are tight.

Apply a high-temperature grease to the four (4) 1-1/2" diameter tumbler drive shaft pillow block bearings. (Use Shell Alvania #3 grease or equivalent.)

Retighten set screws in the collars of the four (4) 1-1/2" diameter tumbler drive shaft bearings.

Clean lint accumulation from the gas valve/burner area at the top of the dryer, the fan (impellor) motor, and the fan (impellor) bearings located in the dryer base.

NOTE: To prevent damage, avoid cleaning and/or touching ignitor/flame-probe assembly.

EVERY 6 MONTHS

Remove the gear oil in the tumbler drive shaft gear reducer. Replace with 1.4 liters of Mobil oil DTE HH5G (I.S.O. viscosity grade 460) or equivalent.

Check the fan (impellor) and drive motor V-belts for tightness and wear. Retighten and replace if required.

STEAM MODELS - clean the steam coil fins. We suggest using compressed air and a vacuum cleaner with brush attachment.

NOTE: When cleaning steam coil fins, be careful not to bend the fins. If fins are bent, straighten by using a fin comb which is available from local air-conditioning supply house.

Inspect and remove lint accumulation in customer furnished exhaust duct work system and from dryers internal exhaust ducting.

NOTE: THE ACCUMULATION OF LINT IN THE EXHAUST DUCT WORK CAN CREATE A POTENTIAL FIRE HAZARD.

NOTE: *DO NOT* OBSTRUCT THE FLOW OF COMBUSTION and VENTILATION AIR. CHECK CUSTOMER FURNISHED BACK DRAFT DAMPERS IN THE EXHAUST DUCT WORK. INSPECT and REMOVE ANY LINT ACCUMULATION WHICH CAN CAUSE THE DAMPER TO BIND or STICK.

NOTE: When cleaning the dryer cabinet(s), avoid using harsh abrasives. A product intended for the cleaning of appliances is recommended.

B. ADJUSTMENTS

7 DAYS AFTER INSTALLATION and EVERY 6 MONTHS THEREAFTER

Inspect bolts, nuts, screws (bearing set screws), non-permanent gas connections (unions, shut-off valves, orifices, and grounding connections). Motor and drive belts **should be** examined. Cracked or seriously frayed belts **should be** replaced. Tighten loose V-belts when necessary. Complete operational check of controls and valves. Complete operational check of **ALL** safety devices (door switch, lint drawer switch, sail switch, burner and hi-limit thermostats).

30 DAYS AFTER INSTALLATION

SHUT OFF ALL POWER TO THE DRYER. Verify that the electrical connections to the motor contactors and overloads are tight. This is done to accommodate the compression of the wires over time.

SECTION VII

COMPONENT SYSTEM DESCRIPTIONS

A. TUMBLER DRIVE SYSTEM

The tumbler is supported and driven by four (4) 11-inch diameter drive wheels. Two (2) of these wheels are attached to a 1-1/2" diameter idler shaft, while the other two (2) are attached to a 1-1/2" diameter drive shaft. Each of the wheels is fastened to the shafts by a trantorque keyless locking bushing. The trantorque is made up of three (3) pieces; an inner collar, an outer sleeve, and a locking nut. The inner and outer elements have matching opposing tapers. As a result, when the nut is tightened, the trantorque contracts onto the shaft and expands into the drive wheel hub locking the wheel onto the shaft. No key is required.

The idler shaft and drive shaft are each supported by two (2) 1-1/2" diameter pillow block bearings. These bearings sit on slotted support channels and can be moved inward or outward by the adjustment bolts to raise or lower the tumbler.

The drive system consists of a shaft mounted gear reducer, two (2) V-belts, and a 5 HP drive motor. Belt tension can be adjusted by tightening or loosening the gear reducer turn buckle.

AD - 310 TUMBLER DRIVE SYSTEM

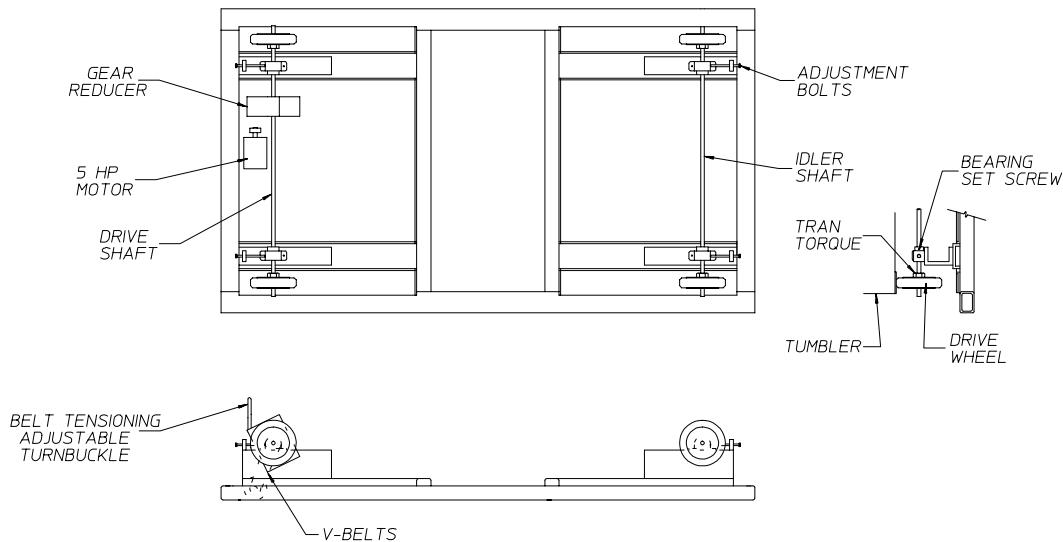

WHEN REPLACING A DRIVE WHEEL:

1. ALWAYS CHANGE BOTH WHEELS ON A SHAFT.
2. MARK POSITION OF BEARINGS ON SUPPORTS. THIS WILL MAKE REASSEMBLY OF SHAFT AND CENTERING OF TUMBLER EASIER.
3. SHOVE BLOCKS OF WOOD UNDER TUMBLER TO TAKE IT'S WEIGHT OFF OF DRIVE WHEELS.
4. REMOVE BEARING HOLD DOWN BOLTS AND ADJUSTMENT BOLTS.
5. SLIDE COMPLETE SHAFT ASSEMBLY OUT OF SIDE OF DRYER.

B. TUMBLER

The tumbler is made of 14-gauge stainless steel perforated panels, four (4) stainless steel ribs, and two (2) outer tumbler rings made of rolled steel angle iron that has been turned on a lathe for smoothness. The tumbler is a completely welded assembly so the perforated panels are not removable.

C. AIR BLOWER DRIVE SYSTEM

The impellor (fan) used in the AD-310 dryer is a 18-1/2" diameter squirrel cage impellor (fan) wheel. It spins in a counterclockwise (CCW) direction looking at the back of the blower housing.

The impellor (fan) shaft is mounted in two (2) pillow block bearing, and the shaft is driven by two (2) B-section V-belts connected to the blower motor.

The blower motor is mounted on an adjustable base. The motor position can be easily adjusted so that proper tension can be maintained on the V-belts.

D. SAFETY DEVICES

1. Load/Unload Door Switches

There are two (2) of these switches located above the main loading doors. These switches ensure that the doors are closed before the dryer can start and ensures that the doors are fully open before the dryer will tilt. If the dryer is started when the load doors are open, the microprocessor controller (computer) L.E.D. display will show "door."

2. Lint Basket Switch

This switch ensures that the lint basket is closed before the dryer can start. This switch is located at the front of the dryer at the right side of the lint basket. If the lint basket is open when the dryer is started, the microprocessor controller (computer) L.E.D. display will show "door."

3. Tumbler Hi-Limit Safety Thermostat

This disc temperature switch has a setting of 225° F. It is located below the tumbler on the temperature sensor bracket, along side the computer (microprocessor) sensor, and is an automatic reset type switch. Access to this switch is gained by sliding/pulling the lint basket completely out of the dryer.

This switch backs up the computer (microprocessor) sensor and in case of a computer (microprocessor) malfunction will prevent the tumbler's temperature from becoming excessive. If this switch trips, the gas flow to the burner boxes will be shut down; however, the tumbler will still rotate.

4. Burner Box Hi-Limit Safety Thermostats (for Gas Dryers ONLY)

These disc temperature switches have a setting of 330° F. They are located on the right side of each burner box, and they are an automatic reset type of switch. These switches ensure that there is proper air flow through the burner box. Upon a low airflow condition, which may be caused by a clogged lint screen, excessively long or blocked exhaust duct, or improper make-up air, the temperature in the burner boxes will increase tripping these switches. This will shut off the gas flow to the burner boxes; however, the tumbler will still rotate.

5. Sail Switches (*for Gas Dryers ONLY*)

These sail switches are located in the front and back of the burner boxes. A sail switch consists of a round damper plate on a lever arm which is in contact with an electric switch. When the air blower comes on, it draws air through the gas burners. This creates a negative pressure inside the burner boxes. This negative pressure pulls in the round damper and activates the sail switches. If there is an improper (low) airflow through the dryer, the sail switch dampers *will not* pull in, preventing the heat from coming on.

Low airflow through the dryer will be caused by overly long or a blockage in the exhaust ducting, lack of make-up air, or a clogged lint screen.

E. STEAM DAMPER ACTUATOR SYSTEM

The system consists of a hinged damper plate, two (2) pneumatic pistons (each with its' own air flow needle valve) to control the speed of both pistons actuation, and a 24 volt solenoid valve.

On a call for heat, a 24 volt signal is applied to the 3-way/2-position solenoid valve. This signal switches the valve so that compressed air is sent to the pistons. The piston rods extend, pushing the hinged steam damper plate to the opened position. This allows room air to be drawn through the hot steam coil and then through the basket (tumbler).

When the temperature set point has been reached, the 24 volt signal is removed from the solenoid valve, so that the solenoid valve blocks the air supply to the pistons, and the air in the pistons is bled to the atmosphere. The springs in the pistons now retract the piston rods, closing the steam damper: The steam damper plate now covers the steam coil and allows room air to bypass the coil before entering the basket (tumbler) for a rapid cool down.

The steam damper plate should open and close slowly and smoothly. The speed can be modulated by adjusting both needle valve knobs. Turning the knob clockwise (CW) restricts the compressed air flow and slows down the steam damper movement. Counterclockwise (CCW) adjustment speeds up the steam damper motion. Upon completion of adjustment, tighten the needle valve's locking nut.

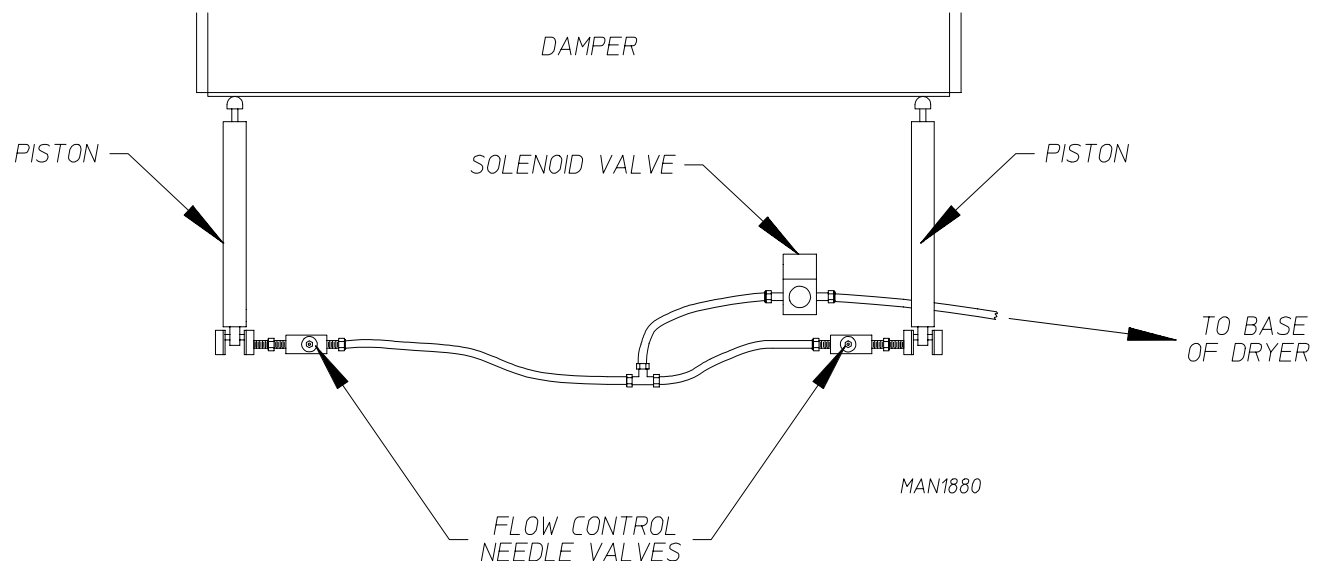

NOTE: TURNING KNOB ON FLOW CONTROL CLOCKWISE WILL RESTRICT AIR FLOW. TURNING KNOB COUNTERCLOCKWISE WILL ALLOW HIGHER AIR FLOW.

SECTION VIII

TROUBLESHOOTING

IMPORTANT: YOU MUST DISCONNECT and LOCKOUT THE ELECTRIC SUPPLY and THE GAS SUPPLY or THE STEAM SUPPLY BEFORE ANY COVERS or GUARDS ARE REMOVED FROM THE MACHINE TO ALLOW ACCESS FOR CLEANING, ADJUSTING, INSTALLATION, or TESTING OF ANY EQUIPMENT per OSHA (Occupational Safety and Health Administration) STANDARDS.

The information provided will help isolate the most probable component(s) associated with the difficulty described. The experienced technician realizes, however, that a loose connection or broken/ shorted wire may be at fault where electrical components are concerned ... and not necessarily the suspected component itself. Electrical parts **should always be** checked for failure before being returned to the factory. The information provided **should not be** misconstrued as a handbook for use by an untrained person making repairs.

IMPORTANT: When replacing blown fuses, the replacement *must be* of the exact rating as the fuse being replaced.

WARNING: ALL SERVICE and TROUBLESHOOTING **SHOULD BE** PERFORMED BY A QUALIFIED PROFESSIONAL OR SERVICE AGENCY.

WARNING: WHILE MAKING REPAIRS, OBSERVE ALL SAFETY PRECAUTIONS DISPLAYED ON THE DRYER or SPECIFIED IN THIS MANUAL.

A. No Display

1. Emergency stop button pushed in.
2. Service panel fuses blown or tripped breaker.
3. Blown F1 (fuse 1) or F2 (fuse 2) on left hand control panel.
4. Blown F4 (fuse 4) or F5 (fuse 5) on right hand control panel.
5. Failed microprocessor controller (computer).
6. Optional sprinkler circuit emergency relay not engaged...
 - a. Service panel fuse blown or tripped breaker.
 - b. Sprinkler circuit is activated.

NOTE: Sprinkler *must have* power for dryer to operate.

B. Drive motor not operating (does not start) ...

*** Microprocessor controller (computer) relay output indicator (either forward "FWD" or reverse "REV") is on.**

1. Blown drive motor contactor fuse(s)/overload(s).
2. Failed drive motor contactor.
3. Failed drive motor.

*** Microprocessor controller (computer) relay output indicator (neither forward "FWD" or reverse "REV") is on.**

1. Failed microprocessor controller (computer).

C. Drive motor operates in one direction only ... stops and restarts in same direction ...

*** Appropriate microprocessor controller (computer) relay output indicator is on.**

1. Failed reversing contactor (relay).

*** Appropriate microprocessor controller (computer) relay output indicator is off.**

1. Failed microprocessor controller (computer).

D. Drive motor operates okay for a few minutes, and then either repeatedly or occasionally trips the overload protector ...

<p>NOTE: When the Overload Protector Trips, the Microprocessor Controller (computer) L.E.D. Display Will Read "door".</p>
--

1. Motor is overheating...
 - a. Motor air vents clogged with lint.
 - b. Low voltage to the motor.
 - c. Failed motor.
 - d. Basket (tumbler) is binding ... check for obstruction.
 - e. Failed gear reducer or tumbler bearings.
 - f. V-belts are too tight.
 - g. Dryer has an oversized load.
2. Failed overload protector.

E. Impellor (fan) motor is not operating (does not start) ...

* **Microprocessor controller (computer) "MTR" relay output indicator is on.**

1. Failed blower (impellor/fan) motor fuse(s) / overload(s).
2. Failed blower (impellor/fan) motor contactor (relay)..
3. Failed blower (impellor/fan) motor.
4. Sail switch engaged prior to start of dry cycle.

* **Microprocessor controller (computer) "MTR" relay output indicator is off.**

1. Failed microprocessor controller (computer).

F. Blower (fan/impellor) motor operates okay for a few minutes, then either repeatedly or occasionally trips the overload protector...

NOTE: When the Overload Protector Trips, the Microprocessor Controller (computer) L.E.D. Display Will Read "door".

1. Motor is overheating...
 - a. Motor air vents clogged with lint.
 - b. Low voltage to the motor.
 - c. Failed motor.
 - d. Tumbler (basket) is binding...check for an obstruction.
 - e. Failed gear reducer or tumbler bearings.
 - f. V-belts are too tight.
2. Failed overload protector.

G. Both drive motor and blower (impellor/fan) motor not operating (do not start) ... microprocessor controller (computer) motor indicator dots and the "MTR" relay output and forward "FWD" or reverse "REV" L.E.D. indicators are on.

1. Blown drive motor and blower (fan/impellor) motor fuse(s) / overload(s).
2. Failed motors (both blower [fan/impellor] and drive).

H. Both drive motor and blower (fan/impellor) motor not operating (do not start) ... microprocessor controller (computer) L.E.D. motor indicator dots and the "door" L.E.D. indicator are on but relay output L.E.D. indicators are off (microprocessor controller [computer] L.E.D. display does not read "door")...

1. Failed microprocessor controller (computer).

I. Microprocessor controller (computer) L.E.D. display reads "dSFL" continuously and the buzzer (tone) sounds every thirty (30) seconds...

1. Fault in microprocessor heat sensing circuit ...
 - a. Failed microprocessor temperature sensor.
 - b. Blown 1/8-amp ("dSFL") fuse on microprocessor controller (computer).
 - c. Failed microprocessor controller (computer).
 - d. Broken wire or connection somewhere between the microprocessor controller (computer) and the microprocessor temperature sensor.

J. Microprocessor controller (computer) L.E.D. display reads "door" and the microprocessor controller "DOOR" L.E.D. indicator is off..

1. Fault (open circuit) in main door/lint drawer switch circuit...
 - a. Lint drawer not closed all the way.
 - b. Lint drawer switch is out of proper adjustment.
 - c. Failed lint drawer switch.
 - d. One (1) of the main door switches has failed.
 - e. One (1) of the main door switch contact magnets is either missing or is broken.
 - f. Failed door switch relay.
 - g. Broken wire/connection in main door or lint drawer switch circuit.
 - h. Drive motor and/or blower (fan/impellor) motor thermal overload reset has tripped.
2. Failed 24 VAC step down transformer.
3. Master control relay (MCR) not engaged.
4. Blown 24 VAC control circuit fuse (fuse 3 [F3]).

K. Microprocessor controller (computer) L.E.D. display reads "door" and the microprocessor controller "door" L.E.D. indicator is on...

1. Failed microprocessor controller (computer).

L. Microprocessor controller (computer) will not accept any keyboard (touchpad) entries, (i.e., L.E.D. display reads "FILL" and when keyboard[touchpad] entries are selected, the L.E.D. display continues to read "FILL")...

1. Dryer is not in level position.
2. Broken connection between level switches.
3. Level switches need to be adjusted.
4. Failed keyboard label (touchpad) assembly.
5. Failed microprocessor controller (computer).
6. Dryer has a "Heater Fault".
7. Selector switch not in "Dry" position.

M. Microprocessor controller (computer) will only accept certain keyboard (touchpad) entries...

1. Failed keyboard label (touchpad) assembly.
2. Failed microprocessor controller (computer).

N. Microprocessor controller (computer) locks up and L.E.D. display reads erroneous message(s) or only partial segments ...

1. Transient power voltage (spikes)...disconnect power to dryer, wait one (1) minute, and reestablish power to dryer. If problem is still evident ...
 - a. Failed microprocessor controller (computer).
 - b. Failed keyboard label (touchpad) assembly.

O. Dryer stops during a cycle, microprocessor controller (computer) buzzer (tone) sounds for 5-seconds, L.E.D. display reads "dSFL," for approximately 30-seconds, and then returns to "FILL" ...

1. Loose connection somewhere between the microprocessor controller (computer) and the microprocessor temperature sensor.

P. Dryer stops during a cycle, microprocessor controller (computer) buzzer (tone) sounds for 5-seconds, and then the microprocessor controller (computer) L.E.D. display returns to FILL" ...

1. Loose connection somewhere in the main power circuit to the microprocessor controller (computer).

Q. Microprocessor controller (computer) L.E.D. display reads "SEFL"...

1. Rotational sensor circuit (option) failure...fault somewhere in basket (tumbler) rotation or circuit ...
 - a. Basket (tumbler) not rotating ...
 - 1) Broken tumbler (basket) drive V-belt(s).
 - 2) Failure in drive motor circuit...refer to **Section B**, **Section C**, and/or **Section D** on *page 70*.
 - b. Failed rotational sensor.
 - c. Broken wire or connection between sensor and microprocessor controller (computer).
 - d. Magnet missing or gap too large.

R. Microprocessor controller (computer) L.E.D. display reads "Hot"...

1. Possible overheating condition...microprocessor controller (computer) has sensed a temperature which has exceeded 220° F.

"Hot" display will not clear until temperature sensed has dropped to 220° F or lower and the microprocessor controller (computer) is manually reset by pressing the "CLEAR/STOP" key.

S. No heat (for STEAM MODELS ONLY) ...both microprocessor controller (computer) L.E.D. heat indicator dot and the "HEAT" relay output L.E.D. are on...

1. Fault in 225° hi-heat (limit) switch circuit or thermostat.
2. No (external) compressed air to steam damper...80 PSI required.
3. Failed steam damper 24 VAC pneumatic solenoid valve.
4. Failed steam damper pistons.
5. Steam damper stuck closed.

T. Dryer operates but is taking too long to dry...

1. Exhaust duct work run is too long or is undersized...back pressure **cannot** exceed .3 inches water column (W.C.).
2. Restriction in duct work...check duct from the dryer all the way to the outdoors.
3. Low and/or inconsistent gas pressure (*for GAS MODELS ONLY*).
4. Insufficient make-up air.

5. Poor air/gas mixture at burner - yellow or poor flame pattern ... adjust gas burner air adjustment shutters (*for GAS MODELS ONLY*).
6. Lint drawer/screen is not being cleaned on a regular basis or often enough.
7. Extractors (washer) not performing properly.
8. Sail switch is fluttering ... restriction in exhaust (*for GAS MODELS ONLY*).
9. Failed microprocessor controller (computer) ... temperature calibration is inaccurate.
10. Failed microprocessor temperature sensor ... calibration is inaccurate.
11. Failed burner hi-limit (*for GAS MODELS ONLY*).
12. Failed 225° hi-limit (thermostat).
13. Steam damper system is not functioning properly (*for STEAM DRYER ONLY*)...
 - a. Steam damper sticking closed.
 - b. Leak in pneumatic system.
14. Undersized load, dryer requires a minimum load size of approximately 125 lbs for maximum drying efficiency.

U. Dryer stops during cycle, microprocessor controller (computer) displays "FILL" and keypad is locked out with heater fault reset button flashing.

1. Dryer is in heater fault...
 - a. Only one of the burners are igniting..
 - 1) Defective gas valve.
 - 2) Bad direct spark ignition module (D.S.I.).
 - b. Gas valve status relays have a broken connection between relays and gas valves or relays and programmable logic controller (PLC).
 - c. Broken connection between programmable logic controller (PLC) to heat or status relay.

V. Excessive noise and/or vibration...

1. Dryer not leveled properly.
2. Impellor (fan/blower) out of balance...
 - a. Excessive lint build up on impellor (fan/blower) ... check air jet.
 - b. Failed impellor (fan/blower).
3. Loose motor mount.
4. Failed idler bearings and/or tumbler bearings.
5. V-belt(s) either too tight or too loose.
6. Tumbler (basket) drive wheels are worn or are loose.
7. Set screws of the tumbler drive shaft bearings are loose.
8. Failed motor bearing.
9. Drive wheel trantorque is loose.

W. Dryer will not tilt...

1. No (external) compressed air to pneumatic switches ... 80 PSI required (11 cf/h).
 - a. Tilting to unload - 1-door ...
 - 1) Dryer will not tilt unless front doors are completely open ...
 - a) No door open signal.
 - b) Defective proximity switch.
 - b. Tilting to unload - 2-doors ...
 - 1) Dryer will not tilt to unload unless front doors are closed.
2. Lint drawer is open.

X. Dryer will not level from a tilt to load position...

1. Lint drawer is open.
2. Defective lint drawer switch.
3. Broken connection between the lint drawer switch and the lint drawer closed relay.

SECTION IX

PROCEDURE FOR FUNCTIONAL CHECK OF REPLACEMENT COMPONENTS

1. Microprocessor (computer) Board

- a. Upon completing installation of the replacement microprocessor (computer) board, reestablish power to the dryer.
- b. Start the drying cycle.
- c. Verify that the motor(s) and the heat indicator dots, in the microprocessor (computer) L.E.D. display are on. (Refer to the illustration below.)

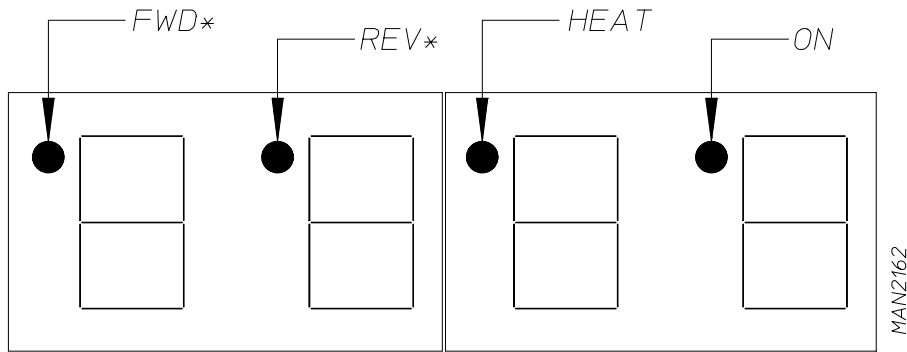

*OPL (NON-COIN) REVERSING MODELS ONLY.

- d. Verify that motor(s) heat, and door indicator lights on the back side of the microprocessor (computer board) are lit. (Refer to illustration below.)

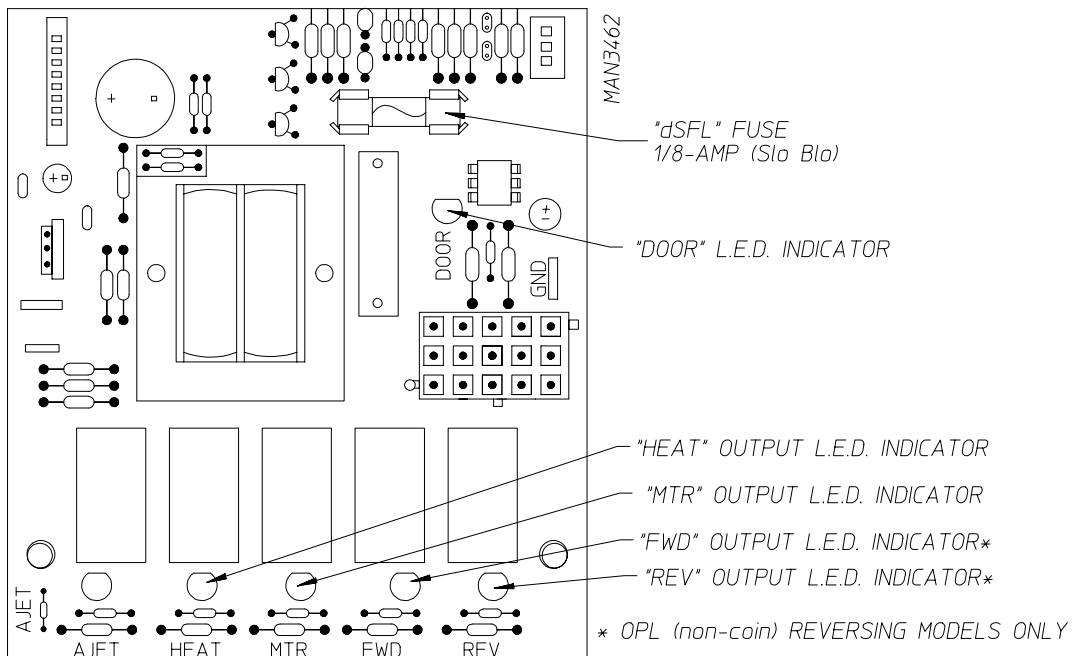

- e. Open main door. The dryer **must stop** and **ALL** output indicator lights on the back side of the microprocessor (computer) board **must go out**.
- f. Try to restart the dryer with the main door open.
- g. The microprocessor (computer) board's L.E.D. display **must read "DOOR."**
- h. Close the main door and restart the dryer.
- i. Functional check of microprocessor (computer) board is complete.

2. Direct Spark Ignition (DSI) System

- a. Upon completing installation of the replacement Direct Spark Ignition (DSI) module, reestablish power to the dryer.
- b. Start the drying cycle.
- c. The ignition (DSI) module's L.E.D. indicator will light "red" for up to approximately 1.5 seconds (pre-purge time).
- d. The module's indicator light will then turn "green." The gas valve will be energized and the ignitor probe will spark for approximately 8 seconds. The burner flame should now be established.
- e. With the burner flame on, remove the flame sensor wire from the FS terminal of the DSI module.
- f. The burner flame **must shut off** and the ignition module **must lock out** with the DSI module's indicator light "red".
- g. Stop the drying cycle, with the flame sensor wire still removed, restart the drying cycle.
- h. The ignition module must proceed through the pre-purge, with the indicator light "red", the ignition trial time of approximately 8 seconds, with the indicator light "green", and then proceed to lock out with the indicator light "red".
- i. Functional check of the Direct Spark Ignition (DSI) Module is complete.
 - 1) Replace the flame sensor wire from the FS terminal to the DSI module.

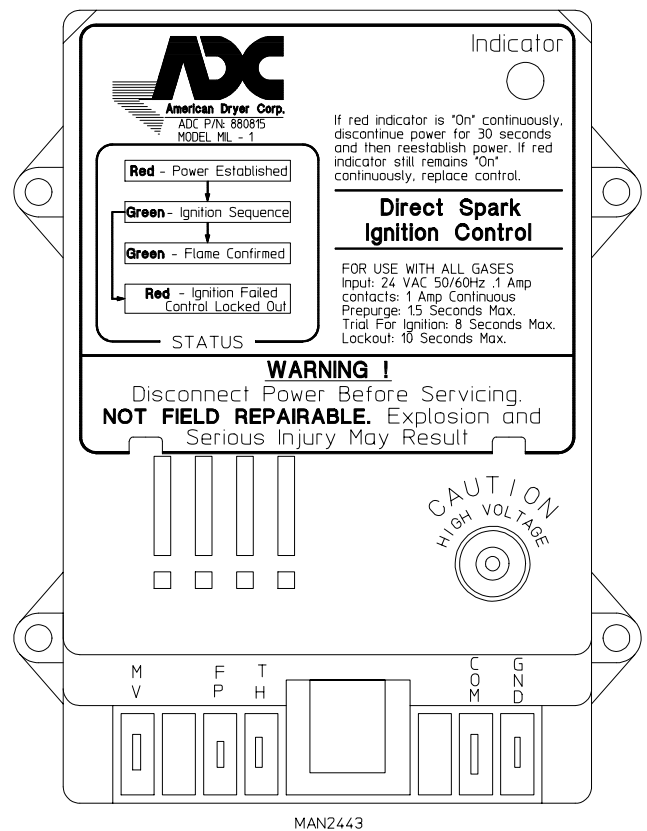

ADC 112191

1- 07/26/96-25
4* 06/20/97-25
7* 07/16/98-25

2* 02/04/97-27
5* 12/24/97-25

3- 06/02/97-2
6- 05/29/98-5

