

ADG-464

Installation/Operator's Manual

WARNING: For your safety the information in this manual must be followed to minimize the risk of fire or explosion or to prevent property damage, personal injury or death.

—Do not store or use gasoline or other flammable vapor and liquids in the vicinity of this or any other appliance.

—WHAT DO YOU DO IF YOU SMELL GAS

- * Do not try to light any appliance.
- * Do not touch any electrical switch; do not use any phone in your building.
- * Clear the room, building or area of all occupants.
- * Immediately call your gas supplier from a neighbor's phone. Follow the gas supplier's instructions.
- * If you cannot reach your gas supplier, call the fire department.

—Installation and service must be performed by a qualified installer, service agency or the gas supplier.

AVERTISSEMENT: Assurez-vous de bien suivre les instructions données dans cette notice pour réduire au minimum le risque d'incendie ou d'explosion ou pour éviter tout dommage matériel, toute blessure ou la mort.

—Ne pas entreposer ni utiliser d'essence ni d'autres vapeurs ou liquides inflammables dans le voisinage de cet appareil ou de tout autre appareil.

—QUE FAIRE SI VOUS SENTEZ UNE ODEUR DE GAZ:

- * Ne pas tenter d'allumer d'appareil.
- * Ne touchez à aucun interrupteur. Ne pas vous servir des téléphones se trouvant dans le bâtiment où vous vous trouvez..
- * Évacuez la pièce, le bâtiment ou la zone.
- * Appelez immédiatement votre fournisseur de gaz depuis un voisin. Suivez les instructions du fournisseur.
- * Si vous ne pouvez rejoindre le fournisseur de gaz, appelez le service des incendies.

—L'installation et l'entretien doivent être assurés par un installateur ou un service d'entretien qualifié ou par le fournisseur de gaz.



For replacement parts, contact the reseller from which the dryer was purchased or

American Dryer Corporation

88 Currant Road

Fall River MA 02720-4781

Telephone: (508) 678-9000 / Fax: (508) 678-9447

E-mail: techsupport@amdry.com

www.amdry.com

Retain This Manual In A Safe Place For Future Reference

American Dryer Corporation products embody advanced concepts in engineering, design, and safety. If this product is properly maintained, it will provide many years of safe, efficient, and trouble-free operation.

ONLY qualified technicians should service this equipment.

OBSERVE ALL SAFETY PRECAUTIONS displayed on the equipment or specified in the installation manual included with the dryer.

The following “**FOR YOUR SAFETY**” caution **must be** posted near the dryer in a prominent location.

FOR YOUR SAFETY

Do not store or use gasoline or other flammable vapors or liquids in the vicinity of this or any other appliance.

POUR VOTRE SÉCURITÉ

Ne pas entreposer ni utiliser d'essence ni d'autres vapeurs ou liquides inflammables dans le voisinage de cet appareil ou de tout autre appareil.

We have tried to make this manual as complete as possible and hope you will find it useful. **ADC** reserves the right to make changes from time to time, without notice or obligation, in prices, specifications, colors, and material, and to change or discontinue models. The illustrations included in this manual may not depict your particular dryer **exactly**.

Important

For your convenience, log the following information:

DATE OF PURCHASE _____ **MODEL NO.** _____ **ADG-464**

RESELLER'S NAME _____

Serial Number(s) _____

Replacement parts can be obtained from your reseller or the **ADC** factory. When ordering replacement parts from the factory, you can **FAX** your order to **ADC** at (508) 678-9447 or telephone your order directly to the **ADC** Parts Department at (508) 678-9000. Please specify the dryer **model number** and **serial number** in addition to the **description** and **part number**, so that your order is processed accurately and promptly.

“IMPORTANT NOTE TO PURCHASER”

Information **must be** obtained from your local gas supplier on the instructions to be followed if the user smells gas. These instructions **must be** posted in a prominent location near the dryer.

IMPORTANT

YOU MUST DISCONNECT and LOCKOUT THE ELECTRIC SUPPLY and THE STEAM SUPPLY BEFORE ANY COVERS or GUARDS ARE REMOVED FROM THE MACHINE TO ALLOW ACCESS FOR CLEANING, ADJUSTING, INSTALLATION, or TESTING OF ANY EQUIPMENT per OSHA (Occupational Safety and Health Administration) STANDARDS.

“Caution: Label all wires prior to disconnection when servicing controls. Wiring errors can cause improper operation.”

«Attention: Lors des opérations d’entretien des commandes étiqueter tous fils avant de les déconnecter. Toute erreur de câblage peut être une source de danger et de panne.»

CAUTION

DRYERS SHOULD NEVER BE LEFT UNATTENDED WHILE IN OPERATION.

WARNING

**CHILDREN SHOULD NOT BE ALLOWED TO PLAY ON OR NEAR THE DRYERS.
CHILDREN SHOULD BE SUPERVISED IF NEAR DRYERS IN OPERATION.**

FOR YOUR SAFETY

DO NOT DRY MOP HEADS IN THE DRYER.

DO NOT USE DRYER IN THE PRESENCE OF DRY CLEANING FUMES.

WARNING

UNDER NO CIRCUMSTANCES should the door switch or the heat circuit devices ever be disabled.

WARNING

The dryer must never be operated with any of the back guards, outer tops, or service panels removed. **PERSONAL INJURY or FIRE COULD RESULT.**

WARNING

DRYER MUST NEVER BE OPERATED WITHOUT THE LINT FILTER (SCREEN) IN PLACE, EVEN IF AN EXTERNAL LINT COLLECTION SYSTEM IS USED.

IMPORTANT

PLEASE OBSERVE ALL SAFETY PRECAUTIONS displayed on the equipment or specified in the installation/operator's manual included with the dryer.

Dryers **must not** be installed or stored in an area where it will be exposed to water or weather.

The wiring diagram for the dryer is located in the front electrical control box area.

Table of Contents

SECTION I

Important Information	3
A. Receiving and Handling	3
B. Safety Precaution	4

SECTION II

Specifications/Dimensions	6
A. Specification	6
B. Dimensions	7

SECTION III

Installation Procedures	8
A. Reassembly of Dryer	8
B. Location Requirement	11
C. Internal Air, Electrical and Water Connections	12
D. External Supply Connections	19
E. Electrical Requirements	22
F. Fresh Air Supply Requirements	25

SECTION IV

Pre Start-up	26
A. Preparation for Operation	26

SECTION V

Routine Maintenance	27
A. Cleaning	27

SECTION VI

Component System Descriptions	29
A. Tumbler Support and Drive System	29
B. Main Air Blower and Heat Reclaimer System	32
C. Compressed Air System	34
D. Gas Burner and Ignition System.....	37
E. Safety Devices	46

SECTION VII

Service and Parts Information 48
A. Service 48
B. Parts 48

SECTION VIII

Warranty

Information..... 49
A. Returning Warranty Cards 49
B. Parts 49
C. Returning Warranty Parts 49

SECTION IX

Troubleshooting 51
Troubleshooting TOC 51

SECTION I

IMPORTANT INFORMATION

A. RECEIVING and HANDLING

The dryer is shipped in a protective stretch wrap cover with protective cardboard corners and top cover (or optional box) as a means of preventing damage in transit. Upon delivery, the dryer and packaging, and wooden skid **should be** visually inspected for shipping damage. If any damage whatsoever is noticed, inspect further before delivering carrier leaves.

Dryers damaged in shipment.

1. **ALL** dryers **should be** inspected upon receipt and before they are signed for.
2. If there is suspected damage or actual damage, the trucker's receipt **should be** so noted.
3. If the dryer is damaged beyond repair, it **should be** refused. Those dryers which were not damaged in a shipment **should be** accepted, but the number received and the number refused **must be** noted on the receipt.
4. If you determine that the dryer was damaged after the trucker has left your location, you should call the delivering carrier's freight terminal immediately and file a claim. The freight company considers this concealed damage. This type of freight claim is very difficult to get paid and becomes extremely difficult when more than a day or two passes after the freight was delivered. It is your responsibility to file freight claims. Dryer or parts damaged in transit **cannot** be claimed under warranty.
5. Freight claims are the responsibility of the consignee, and **ALL** claims **must be** filed at the receiving end. **ADC** assumes no responsibility for freight claims or damages.
6. If you need assistance in handling the situation, please contact the **ADC** Traffic Manager at (508) 678-9000.

IMPORTANT: The tumbler section of the dryer **must be** transported and handled in an upright position at all times.

B. SAFETY PRECAUTIONS

WARNING: For your safety, the information in this manual *must be* followed to minimize the risk of fire or explosion or to prevent property damage, personal injury, or loss of life.

WARNING: The dryer must never be operated with any of the back guards, outer tops, or service panels removed. **PERSONAL INJURY or FIRE COULD RESULT.**

1. **DO NOT** store or use gasoline or other flammable vapors and liquids in the vicinity of this or any other appliance.
2. Purchaser or user should consult the local supplier for proper instructions to be followed in the event the user smells gas. The instructions **should be** posted in a prominent location.
3. WHAT TO DO IF YOU SMELL GAS ...
 - a. **DO NOT** try to light any appliance.
 - b. **DO NOT** touch any electrical switch.
 - c. **DO NOT** use any phone in your building.
 - d. Clear the room, building or area of **ALL** occupants.
 - e. Immediately call your gas supplier from a neighbor's phone. Follow the gas suppliers' instructions.
 - f. If you **cannot** reach your gas supplier, call the fire department.
4. Installation and service **must be** performed by a qualified installer, service agency or gas supplier.
5. Dryers **must be** exhausted to the outdoors.
6. Although **ADC** produces a very versatile machine, there are some articles that, due to fabric composition or cleaning method, **should not** be dried in it.

WARNING: Dry only water-washed fabrics. **DO NOT** dry articles spotted or washed in dry cleaning solvents, a combustible detergent or "all purpose" cleaner.
EXPLOSION COULD RESULT.

WARNING: **DO NOT** dry rags or articles coated or contaminated with gasoline, kerosene, oil, paint or wax.
EXPLOSION COULD RESULT.

WARNING: **DO NOT** dry mop heads. Contamination by wax or flammable solvents will create a fire hazard.

WARNING: **DO NOT** use heat for drying articles that contain plastic, foam, sponge rubber or similarly textured rubber materials. Drying in a heated basket (tumbler) may damage plastics or rubber and also may be a fire hazard.

7. A program **should be** established for the inspection and cleaning of lint in the burner area, exhaust duct work, and inside the dryer. The frequency of inspection and cleaning can best be determined from experience at each location.

WARNING: The collection of lint in the burner area and exhaust duct work can create a potential fire hazard.

8. For personal safety, the dryer **must be** electrically grounded in accordance with local codes and/or the NATIONAL ELECTRIC CODE ANSI/NFPA NO. 70-LATEST EDITION, or in Canada, the CANADIAN ELECTRICAL CODES PARTS 1 & 2 CSA C22.1-1990 or LATEST EDITION.

NOTE: Failure to do so will VOID THE WARRANTY.

9. **UNDER NO CIRCUMSTANCES** should the dryer door switches, lint drawer switches, heat safety circuit, or tilt switches ever be disabled.

WARNING: PERSONAL INJURY or FIRE COULD RESULT.

10. This dryer is not to be used in the presence of dry cleaning solvents or fumes.

11. Remove articles from the dryer as soon as the dryer cycle has been completed.

WARNING: Articles left in the dryer after the drying and cooling cycles have been completed can create a fire hazard.

12. **READ and FOLLOW ALL CAUTION and DIRECTION LABELS ATTACHED TO THE DRYER.**

WARNING: YOU MUST DISCONNECT and LOCKOUT THE ELECTRICAL SUPPLY and THE GAS SUPPLY BEFORE ANY COVERS or GUARDS ARE REMOVED FROM THE MACHINE TO ALLOW ACCESS FOR CLEANING, ADJUSTING, INSTALLATION OR TESTING OF ANY EQUIPMENT per OSHA (Occupational Safety and Health Administration) STANDARDS.

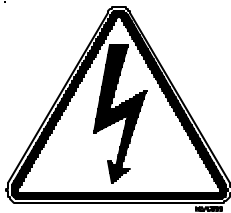

The lightning flash with an arrow head within an equilateral triangle, is intended to alert the user to the presence of non-insulated “dangerous voltage” within the products enclosure that may be sufficient in magnitude to constitute a risk of electrical shock to any person.



The Exclamation point “!” within an equilateral triangle is intended to alert the user to the presence of important operating and maintenance (servicing) instructions in the literature accompanying the appliance.

SECTION II

SPECIFICATIONS/DIMENSIONS

A. SPECIFICATIONS

MAXIMUM CAPACITY (DRY WEIGHT)	460 LBS.	208.66 KG
TOTAL WEIGHT	9,550 LBS.	4,331.8 KG
TOTAL SHIPPING WEIGHT	9,800 LBS.	4,445.21 KG
TILT HEIGHT	137-1/4"	348.6 CM
OPERATING HEIGHT	114-1/2"	290.83 CM
FULL TILT DEPTH	117-1/2"	298.45 CM
OPERATING DEPTH	95"	241.3 CM
WIDTH	122"	309.88 CM
TILT LOAD (REAR TILT)	15°	
TILT UNLOAD (FRONT TILT)	15°	
UNLOADING HEIGHT FROM FLOOR	43-3/4"	111.12 CM
LOADING HEIGHT FROM FLOOR	65-5/8"	166.69 CM
DOOR OPENING	53-1/4" x 49"	135.26 CM x 124.46 CM
TUMBLER (BASKET) DIAMETER	69-1/8"	175.58 CM
TUMBLER (BASKET) DEPTH	80-5/16"	203.99 CM
TUMBLER (BASKET) VOLUME	175 CU. FT.	4.96 CU. M
MINIMUM LOAD SIZE	250 LBS.	113.4 KG
MAXIMUM LOAD SIZE	460 LBS.	208.66 KG
BURNER TYPE	ON/OFF	
HEAT INPUT*	2,800,000 BTU/HR.	705,588 KCAL/HR.
BLOWER MOTOR	25 HP	18.64 KW
TUMBLER (BASKET) MOTORS	(2) 5 HP	(2) 5.6 KW
BURNER BLOWER MOTOR	1-1/2 HP	1.12 KW
BLOWER MAXIMUM AIRFLOW	13,000 CFM	368 CM. M
MAXIMUM DUCT BACK PRESSURE	1.25" (W.C.)	3.1 MBAR
MINIMUM DUCT PRESSURE	24"	60.96 CM
COMPRESSED AIR PRESSURE REQUIRED	80 PSI (± 10 PSI)	5.63 KG/CM (±.70)
COMPRESSED AIR VOLUME REQUIRED	20 CF/HR	.57 CM/HR
COMPRESSED CONNECTION	3/8" N.P.T.	.95

Shaded areas are stated in metric equivalents.

* Gas pressure into the dryer **cannot** exceed 13" water column (W.C.) -32.34 m bar-. If the gas pressure is higher than 13" W.C., (32.34 m bar) an external regular **must be** installed.

NOTE: ADC reserves the right to make changes in specifications at any time, without notice or obligation.

B. DIMENSIONS

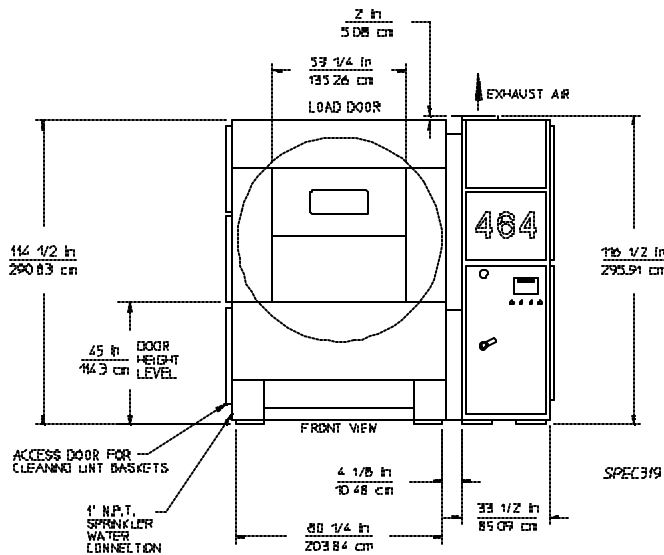
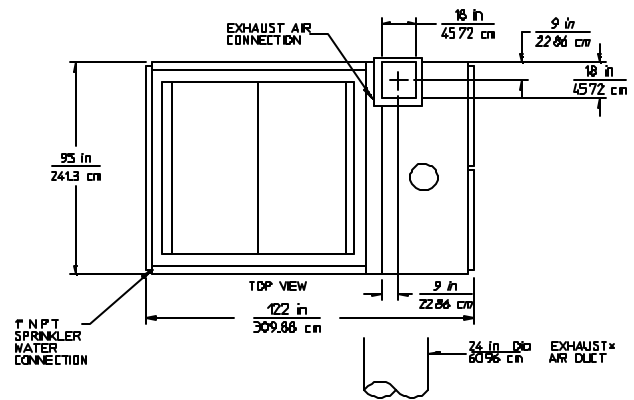

*DUCT WORK MUST BE A MINIMUM OF 24" DIAMETER (609.6 mm) DUCT WORK SIZE VARIES WITH INSTALLATION CONDITIONS



NOTE: ADC reserves the right to make changes in specifications at any time, without notice or obligation.

SECTION III

INSTALLATION PROCEDURES

Installation **should be** performed by competent technicians in accordance with local and state codes. In the absence of these codes, the installation **must conform** to applicable AMERICAN NATIONAL STANDARDS: National Fuel Gas Code ANSI.Z223.1-LATEST EDITION or National Electric Code ANSI/NFPA NO. 70-LATEST EDITION or in Canada, the installation **must conform** to applicable Canadian Standards: CAN/CGA-B149.1-M91 (Natural Gas) or CAN/CGA-B149.2-M91 (L.P. Gas) or LATEST EDITION (for General Installation and Gas Plumbing) or Canadian Electrical Codes Parts 1 & 2 CSA C22.1-1990 or LATEST EDITION (for Electrical Connections)

A. REASSEMBLY OF DRYER

IMPORTANT: Always keep the tumbler (basket) section of the dryer in an upright position when moving it.

1. Reassembly Instructions for Dryer Shipped in Two (2) Pieces

In this method of shipment, the tumbler section and the tumbler base section are shipped as one unit and the heat console section is the second.

a. Reassemble Tumbler (Basket) and Tumbler (Basket) Base Section To The Heat Console Section

Move both pieces into position by lifting them with cables through the eyebolts located at the top of each of the two sections. These pieces may also be moved into place with a fork (lift) truck by lifting the pieces from underneath. The tumbler and tumbler base section weighs about 6,400 pounds (2,903 kg) and the heat console section weighs about 4,100 pounds (1,860 kg). Once the sections are in position, the seven (7) clearance holes on the tumbler (basket) base section (four [4] in the front and three [3] in the rear) **must be** aligned with the seven (7) #3/8-16 tapped holes in the heat console section. Use the three (3) #8-16 x 2" long bolts along with the tapered shims supplied to bolt the two sections together.

b. Reattach The Control Pendant Arm

Position the control pendant arm to the top front of the heat console section by aligning the clearance holes in the arm with the 1/4-20 tapped holes on the top of the heat console section. Use the 1/4-20 x 3" long bolts supplied with the machine to attach the arm to the console.

c. Reconnect The Internal Air, Electric Connections, and Water Connections (refer to **page 12 through page 19**)

2. Reassembly Instructions For Dryers Shipped In Three (3) Pieces

When the dryer is shipped in three pieces, the tumbler and the tumbler base sections are shipped as two (2) separate pieces. The heat console section is shipped as the third piece.

a. Reassemble The Tumbler (Basket) Base Section To The Heat Console Section

Move the heat console section into position by using cables through the eye bolts located at the top of the section or by using a fork truck and lifting the section from underneath. The tumbler (basket) base section is now moved into position with a fork (lift) truck. The seven (7) clearance holes located on the right side of the tumbler (basket) base section (four [4] holes in front and three [3] at the back of the section) **must be** aligned with the seven (7) 3/8-16 tapped holes on the left side of the heat console section. Use the 3/8-16 x 3" long bolts and the tapered shims supplied with the unit to bolt the section together.

b. Reassemble The Tumbler (Basket) Section Over The Tumbler (Basket) Base

Slowly lower the tumbler (basket) section over the tumbler base. The four (4) large slots located on the bottom of the tumbler (basket) section (one slot at each corner of the tumbler [basket] section) **must be** aligned with the top of the pistons in the tumbler base section. Use the four (4) 1-1/4-12 x 3-1/2" long bolts supplied with the unit to secure the tumbler (basket) section to the tumbler (basket) base section.

c. Reattach The Control Pendant Arm

Position the control pendant arm to the top front of the heat console section by aligning the clearance holes in the arm with the 1/4-20 tapped holes on the top of the heat console section. Use the 1/4-20 x 3" long bolts supplied with the machine to attach the arm to the console.

d. Reconnect The Internal Air, Electric Connections, and Water Connections (refer to **page 12 through page 19**).

3. Reassembly Instructions for Dryer Shipped in Four Pieces

In this method of shipment the tumbler section, tumbler (basket) base, lower heat console, and upper heat console are **ALL** shipped as separate sections.

a. Reassemble The Heat Console Section

Apply silicone (provided with unit) to the flanges of the lower heat console section. Lift the upper heat console section by use of cables through the eyebolts located on the top of the upper console section. Position the upper heat console over the lower heat console section. Use the 5/16-18 hardware provided with the machine to secure the sections together.

b. Reassemble The Tumbler (basket) Base Section To The Heat Console Section

Move the heat console section into position by using cables through the eyebolts located at the top of the section or by using a fork (lift) truck and lifting the section from underneath. The tumbler (basket) base section is now moved into position with a fork (lift) truck. The seven (7) clearance holes located on the right side of the tumbler (basket) base section (four [4] holes in the front and the three [3] at the back of the section) **must be** aligned with the seven 3/8-16 tapped holes on the left side of the heat console section. Use the 3/8-16 x 2" long bolts and the tapered shims supplied with the unit to bolt the sections together.

c. Reassemble The Tumbler (Basket) Section To The Tumbler (Basket) Base

Lift the tumbler (basket) section with a cable through the eye bolts on top of the section. Slowly lower the tumbler (basket) section over the tumbler base. The four (4) large slots located on the bottom of the tumbler (basket) section (one slot at each corner of the tumbler section) **must be** aligned with the tapped holes in the cylinder cleaves located at the top of the tumbler (basket) section. Use the four (4) 1-1/4-12 x 3-1/2' long bolts supplied with the unit to secure the tumbler (basket) section to the tumbler (basket) base section.

d. Reattach The Control Pendant Arm

Position the control pendant arm on the top front of the heat console section by aligning the clearance holes in the arm over the 1/4-20 tapped holes in the top of the heat console section. Use the 1/4-20 x 3" long bolts supplied with the unit to attach the arm to the console.

e. Reconnect The Internal Air, Electric Connections, and Water Connections (refer to **page 12 through page 19**).

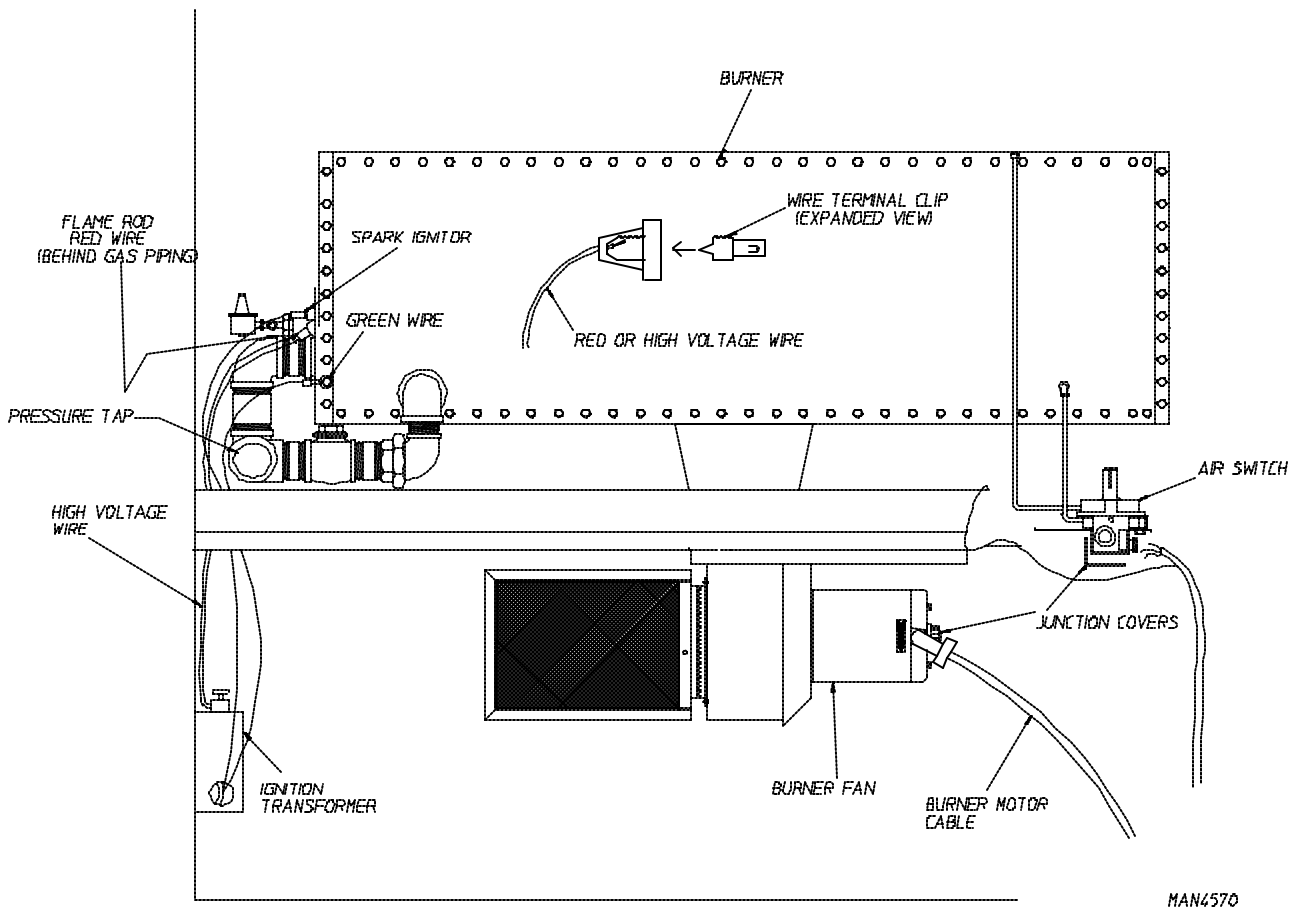

B. LOCATION REQUIREMENTS

The model ADG-464 dryer requires 36-inches (91.44 cm) of space on each side of the dryer and 36-inches (91.44 cm) of space behind the unit for ease of maintenance and tilting. The dryer **must be** leveled for proper operation. If shimming is required, put (24.13 cm) 9-1/2" x 9-1/2" (24.13 cm) metal shims under the base feet. The dryer **must be** lagged to the floor.

IMPORTANT: Dryer *should be* located where a minimum amount of exhaust duct will be necessary.

1. The dryer **must be** installed with a proper exhaust duct connecton to the outside.
2. The dryer **must be** installed with provisions for adequate combustion and make-up air supply.

CAUTION: This dryer produces combustible lint and *must be* exhausted to the outdoors. Every 6 months, inspect the exhaust ducting and remove any lint build up.

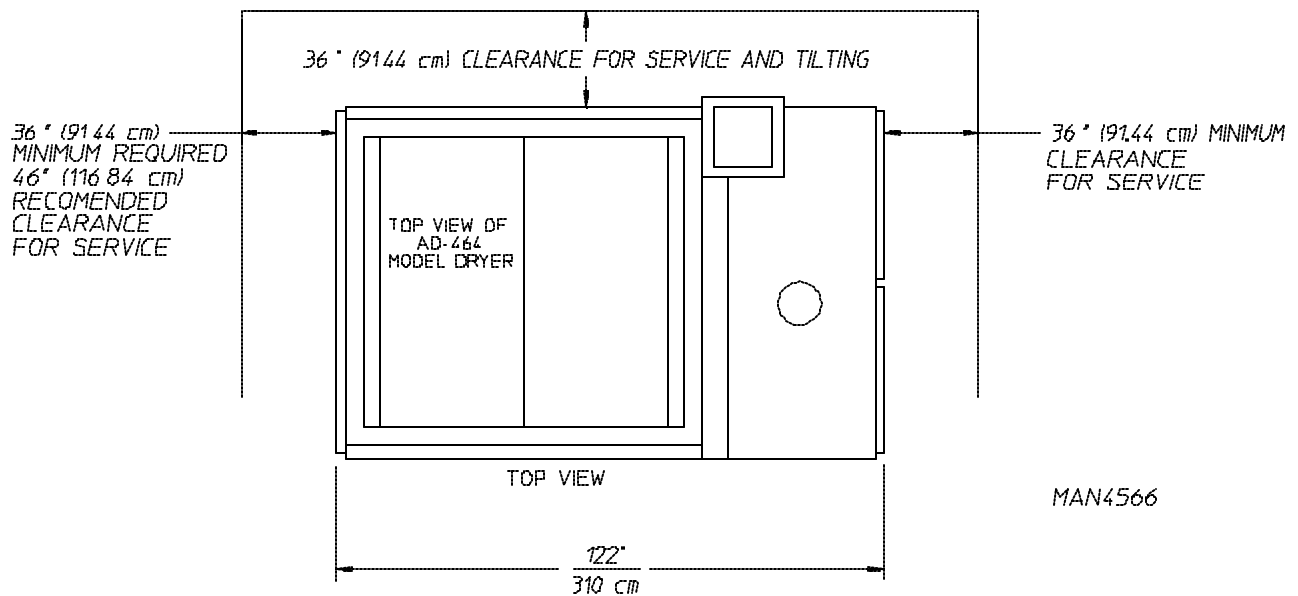

CLEARANCE ALLOWANCE

IMPORTANT MINIMUM CLEARANCE BETWEEN TOP OF DRYER AND NEAREST OBSTRUCTION MUST BE 36" (91.44 cm)

C. INTERNAL AIR, ELECTRIC and WATER CONNECTIONS

1. Air

a. Front Tilt Piston and Sprinkler lines

This connection is made at the front of the dryer in the area between the lower heat console section and the tumbler (basket) base section. To connect the sprinkler air line insert the 1/4" aluminum tubing into the 1/4" brass compression fitting and tighten the fitting nut. To connect the 3/8" poly-flo tubing to the corresponding brass fittings, match the marked number on the tube with the number on the brass fitting. After inserting the corresponding tubes into the brass fittings. Tighten the brass fitting nuts.

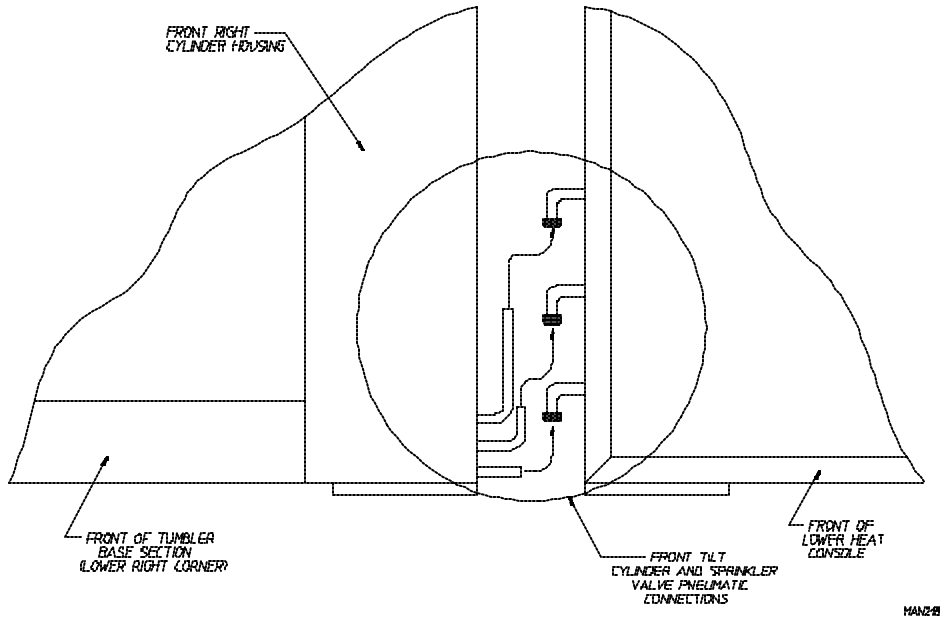

b. Rear Tilt Piston Lines

This connection is made at the rear of the dryer in the space between the lower heat console section and the tumbler (basket) base section. Insert the 3/8" poly-flo tube coming from the tumbler (basket) base section to the 3/8" brass fitting marked with the corresponding number. Do the same to the second tube and brass fitting. Tighten the brass fitting nuts.

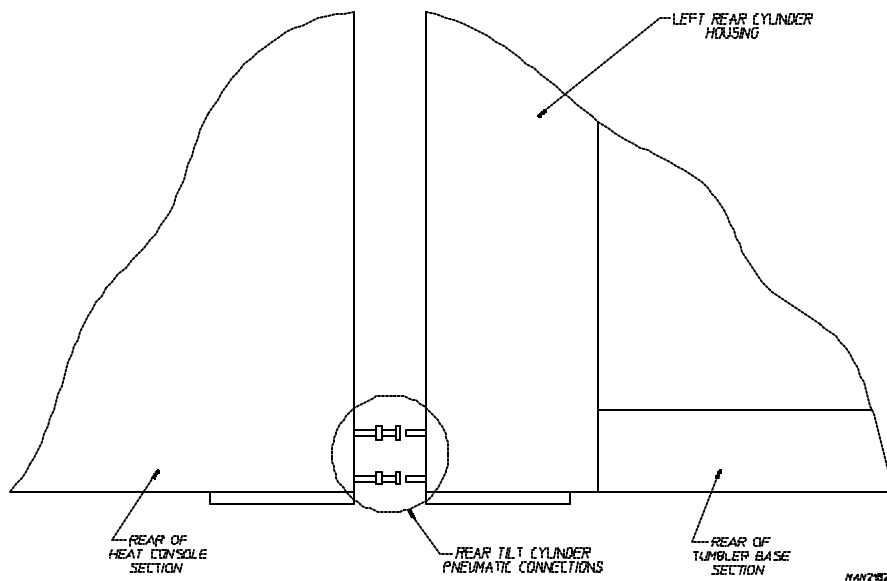

c. Load Door Piston Lines

The load door cylinder pneumatic connections are made in the lower heat console section, in the area behind the pneumatic panel. To connect the 1/4" poly-flo tubing into the corresponding needle valves, match the number on the line with the number on the needle valve. Insert **ALL** of the tubing (two [2] on a 1-Door model, four [4] on a 2-Door model) into their corresponding valves. Give a moderate pull on **ALL** of the air lines to make sure that the connection are complete.

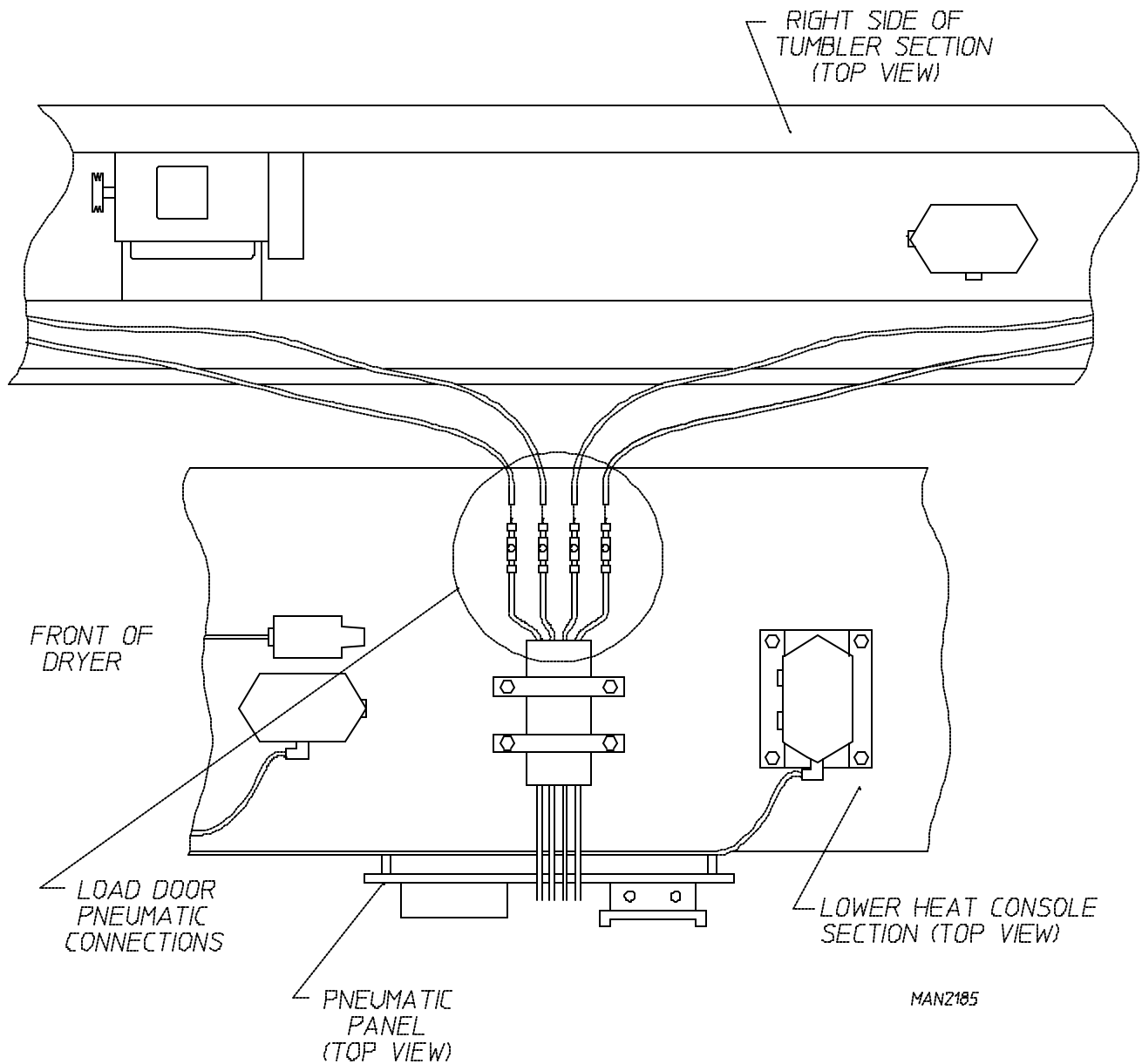

2. Electric

a. Burner Switch and Air Switch

These connections are made between the upper heat module and the lower heat module section. To connect the burner, there are three (3) wires that come from the ignition transformer through (2) holes on the bottom of the upper heat module. The green and red wires are fed through the hole closest to the doors and the high voltage wire gets put through the hole nearest the tumbler. The green wire has a ring terminal that gets mounted to the burner assembly. The red and high voltage wires need to have the provided connectors installed on the ends of the wires. Take stripped end of the wire and put it through the end of the black cap, then, tighten the metal end clip. The red wire goes on the flame probe behind the pilot line and the high voltage wire goes on the spark plug (spark plug closest to the front).

b. Burner Fan

The burner fan connections are made in the back of the burner fan motor. Remove the two (2) screws that hold the cover to the junction box of the motor. The burner fan cable with the four (4) conductors in it can be found next to the heat reclaimer piston. Connect the 90° end connector of the cable to the motor junction box with the lock nut. After the cable is mechanically fastened to the motor begin to connect the wires with the same color tape identifiers together. (**CAUTION: There may be more than two [2] connections at one junction**) with wire and PVC electrical tape.

The green wire is ground and gets connected to the ground lug in the motor. Replace the two (2) screws and the cover for the burner motor junction area.

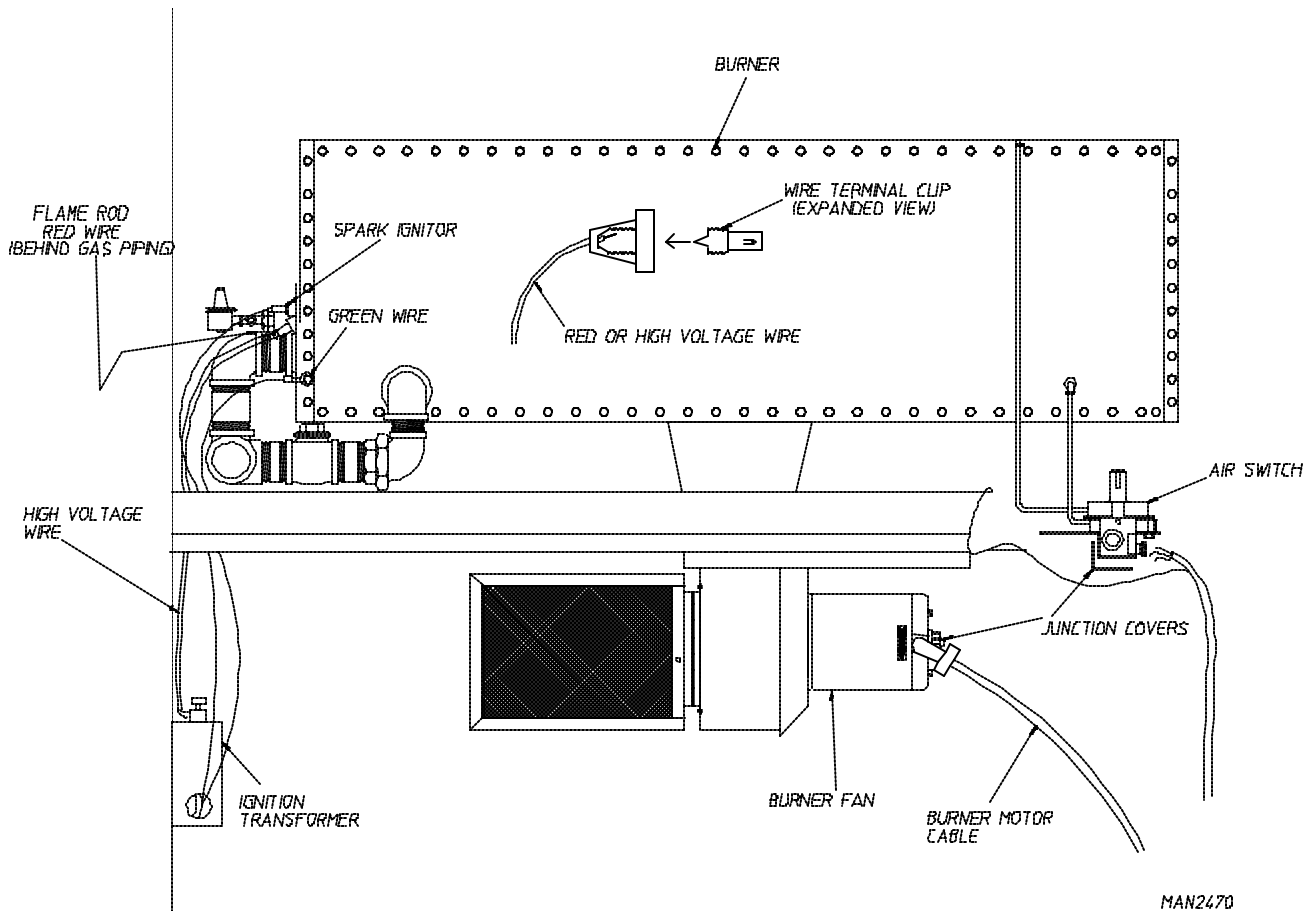

c. Tumbler (Basket) Motors

The disconnects for the two (2) tumbler (basket) motors are located in the lower heat console. The right drum (tumbler/basket) motor disconnect is located in the lower heat console on the upper shelf towards the left. The left drum (tumbler/basket) motor disconnect is located in the base of the lower heat console to the right. On both cables the mechanical connections **should be** made to the respective junction box. Remove the two (2) screws that hold down the cover of each junction box. Insert cable end in the junction box and fasten with lock nut. Then begin to connect the four (4) wires with the same color tape identifiers together with the four (4) wires already in the junction box. Make these connections with wire nuts and PVC electrical tape. Replace the cover and the cover (2) screws that hold down the cover to the junction box.

d. Temperature Probe, Base, and Tumbler (Basket) Disconnects

The disconnects are located in the lower heat console. The temperature probe disconnect is located on the upper shelf towards the left. The base disconnect and the tumbler (basket) disconnect are located on the base towards the right. Check identifying tapes to ensure proper assignments of connectors to the proper base. Check for proper keying and connect disconnect to the proper base. Engage hold downs on base and verify that the clamps are properly locked.

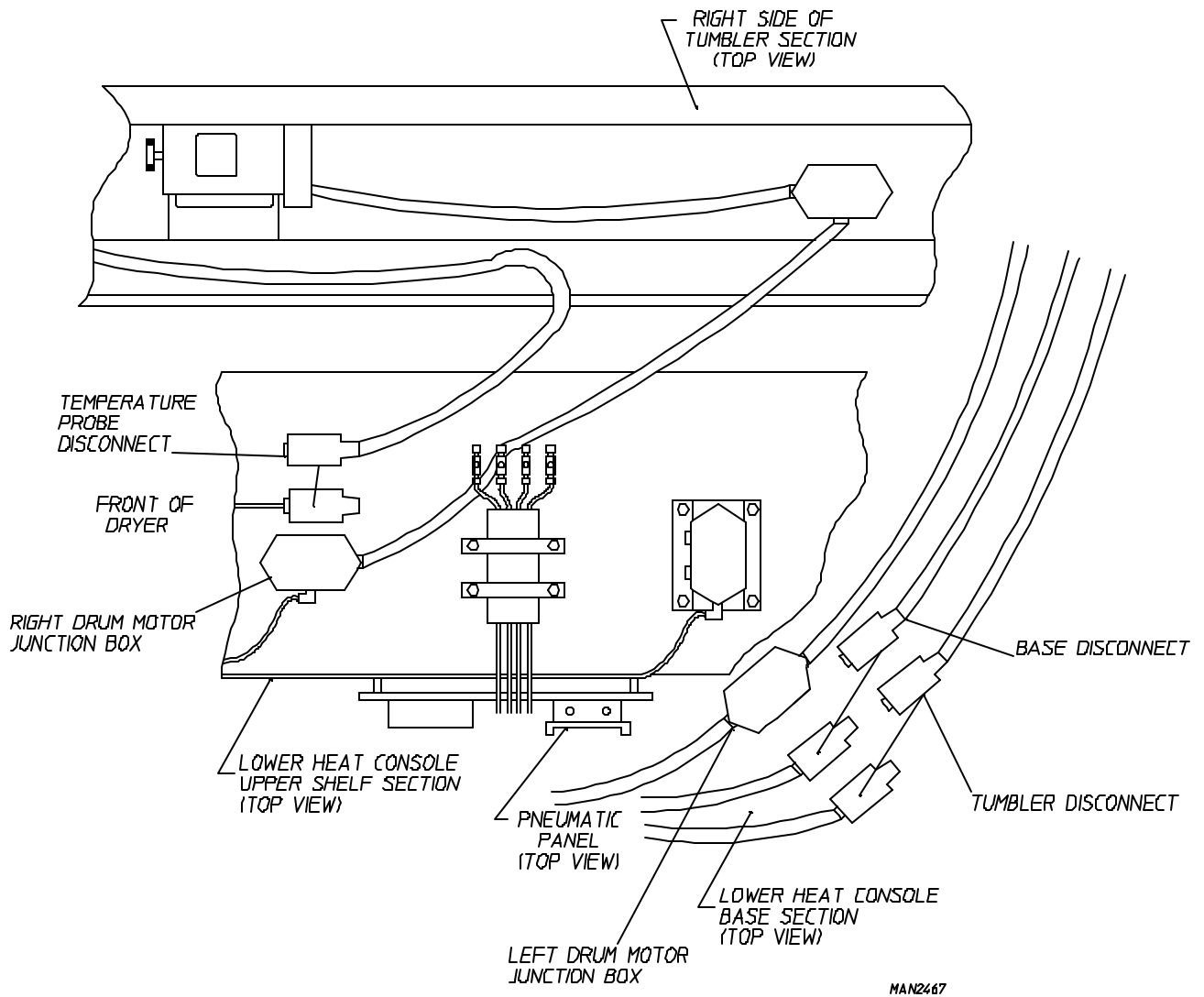

MAN2467

e. Annunciator, Pendant, Over-Burner, and RTD (Resistive Temperature Device) Cable

Remove the four (4) bolts that hold on the character (464) panel. Open the door to the main electrical enclosure, the female end of the RTD (Resistance Temperature Device) cable will be found there. Loosen the 1-inch lock nut and remove the modified hole seal. Put the female end of the RTD cable through the hole in the top of the electrical enclosure. Connect the male end and the female end of the RTD cable together, pull the cable up until the threads of the reducing bushing can be seen through the hole into where the character (464) panel was. Next, get the 1-inch lock nut on by a few threads, slip the modified hole seal under the lock nut holding the 45° cord grip connector, then tighten the 1-inch lock nut. Replace the character (464) panel and tighten the four (4) bolts.

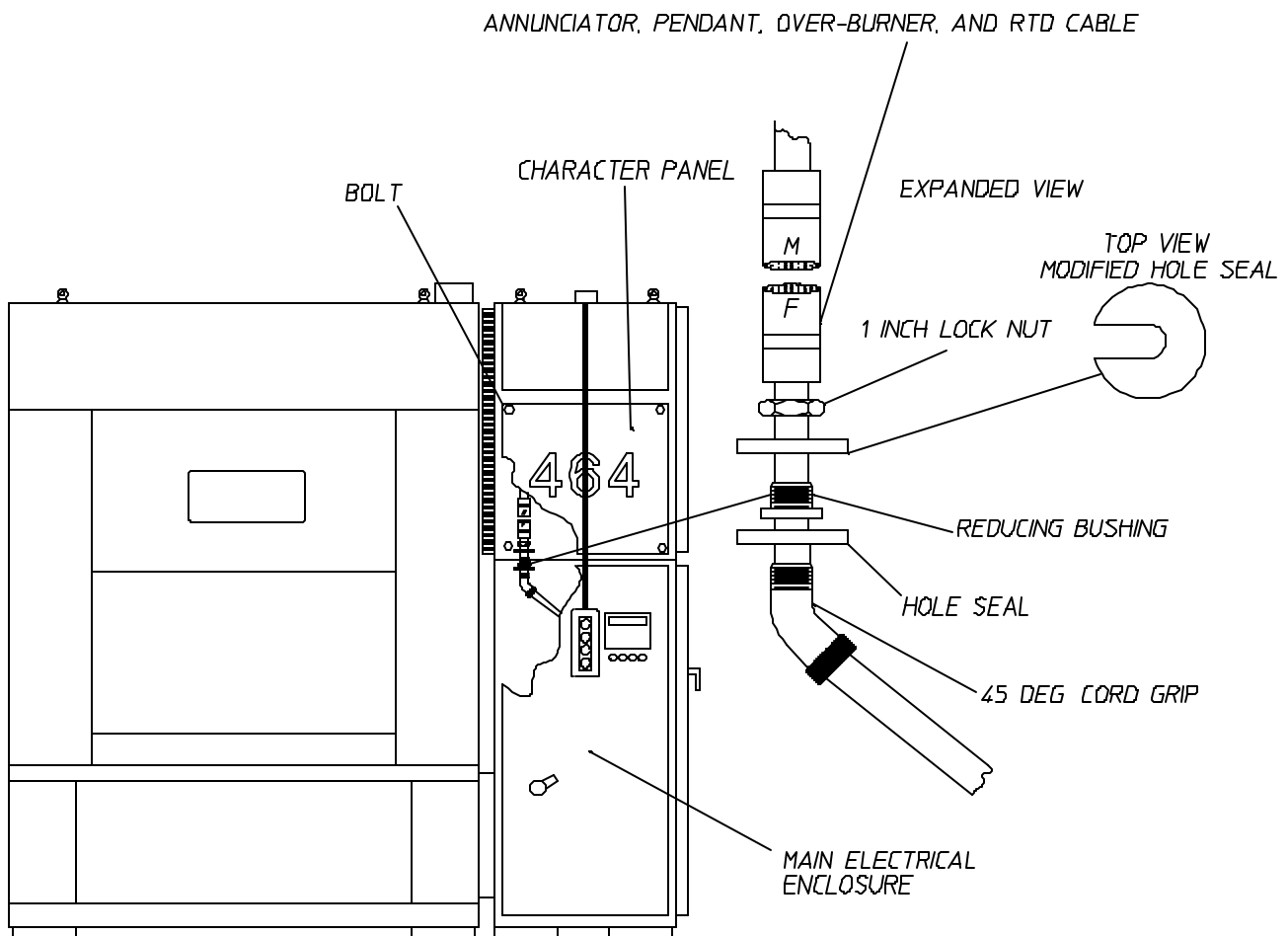

MAN2468

d. Pendant

On the top of the heat console section of the dryer near the pendant, there is a junction box with four (4) cables coming out of it. Two (2) of the cables from the junction box have connectors on the end, a 5-pin connector and an 11-pin connector. Coming out of the pendant **should be** two (2) cables, one with a 5-pin connector and the other with an 11-pin connector. Match up the four (4) cables into assigned pairs, check keying and connect the male and female connection together.

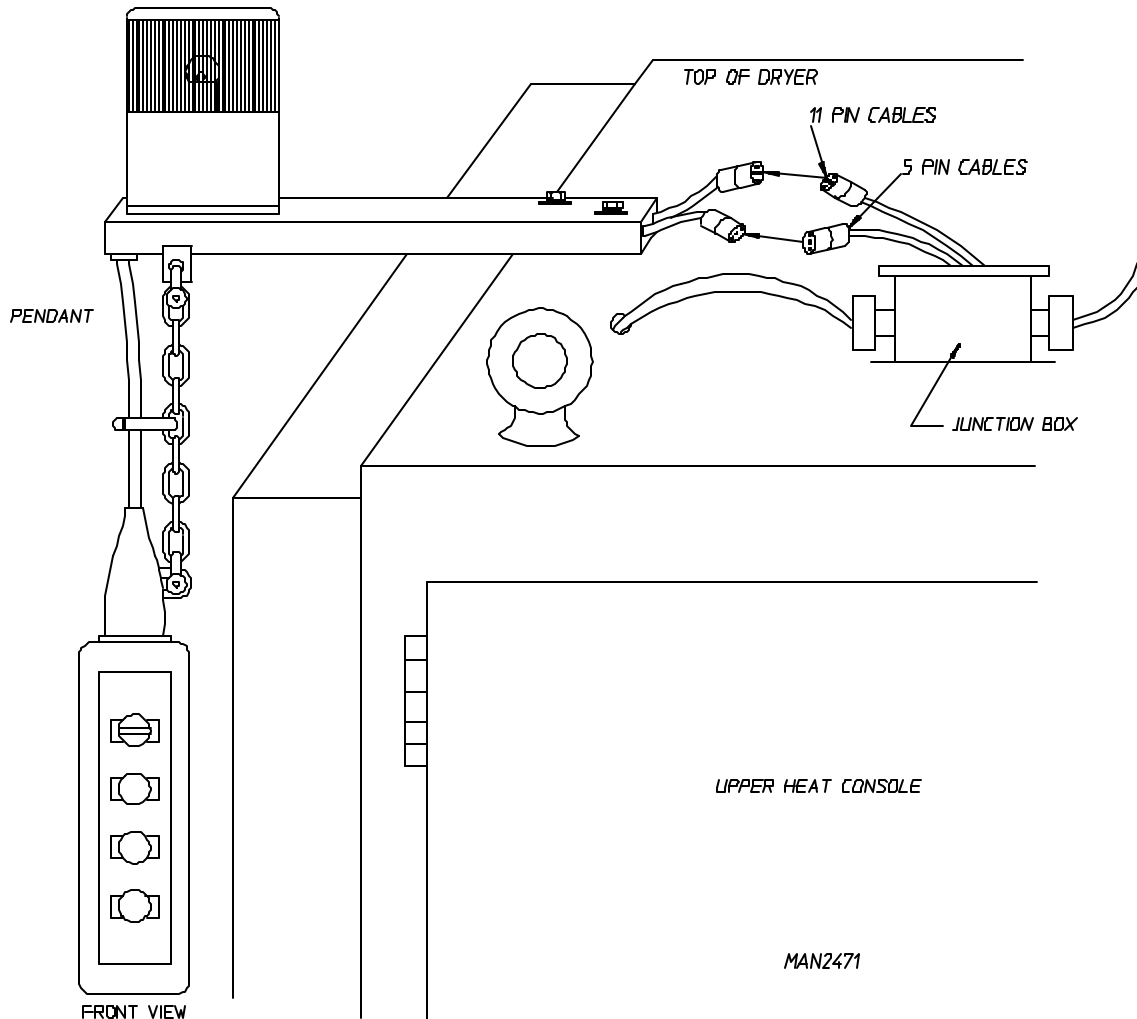

e. Tumbler Junction Box Disconnect

Remove the four (4) bolts that hold on the lower left side panel, then remove the panel. The safety panel is next to be removed. This is done by removing the six (6) bolts on the bottom of the safety panel where the tumbler (basket) section and the base meet. Reach into the feed through hole in the base of the tumbler (basket) section, there will be two (2) cables there. Pull both cables through the hole into the tumbler (basket) section. The cable with the connector on the end is for the tumbler (basket) junction box, the other cable is for the left drum motor. Leave that cable in the tumbler (basket) section (it will be covered in **Section f** [Left Drum Motor] on **page 18**). Check keying between the plug and tumbler (basket) junction box. Insert plug into connector on the junction box and engage locking clasps. Leave the lower left side panel and the safety panel off the machine until left drum motor is reconnected (refer to **Section f** [Left Drum Motor] on **page 18**).

f. Left Drum Motor

There are two (2) different ways that the left drum motor is connected with or without the motor disconnect junction box. The junction box is used when the connections to the left motor are made on the back side of the motor, nearest to the tumbler (basket). When connecting the motor, bring the left drum motor cable (refer to *Section e* [Tumbler Junction Box Disconnect] on [page 17](#)) and mechanically connect it to the junction box on the motor or the external junction box with the lock nut. There will be four (4) wires in the cable, match them with the PVC electrical tape. There **should be** one (1) green wire remaining, which is used for the ground connection. Replace the screws that go on the cover of the junction box. Bolt the safety panel back in place using the six (6) bolts removed in *Section e* (Tumbler Junction Box Disconnect) on [page 17](#), then bolt the lower left side panel back in to place using the four (4) bolts also removed in *Section e* (Tumbler Junction Box Disconnect) on [page 17](#).

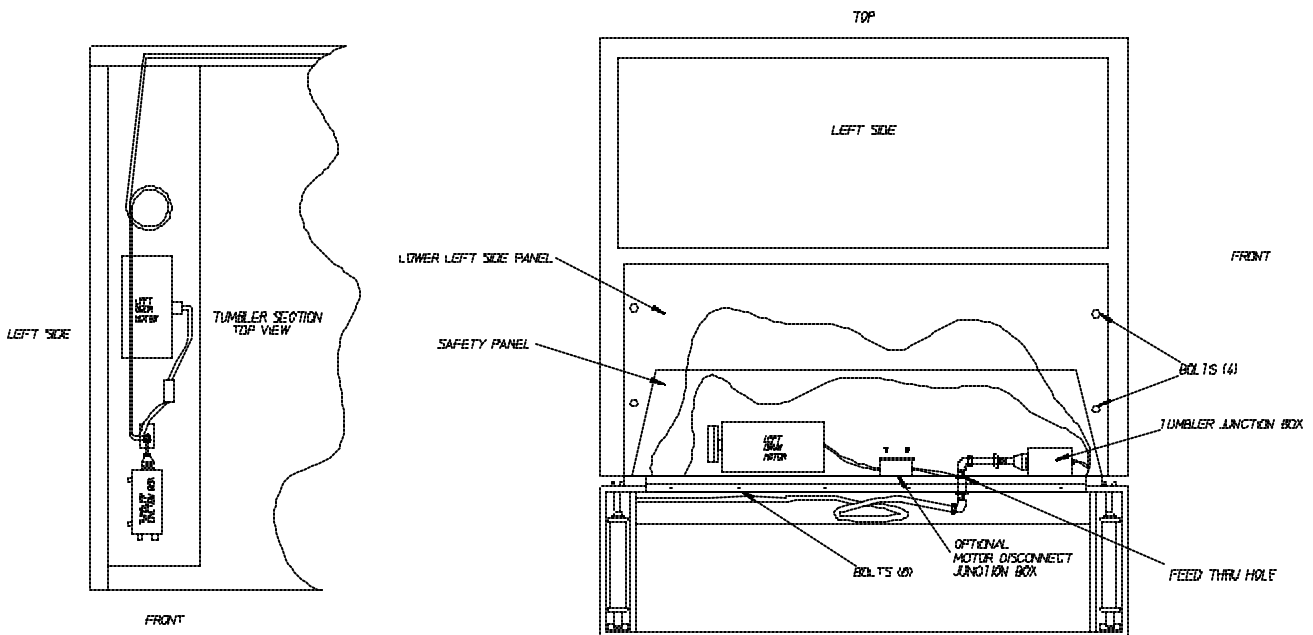

MAN2469

D. EXTERNAL SUPPLY CONNECTIONS

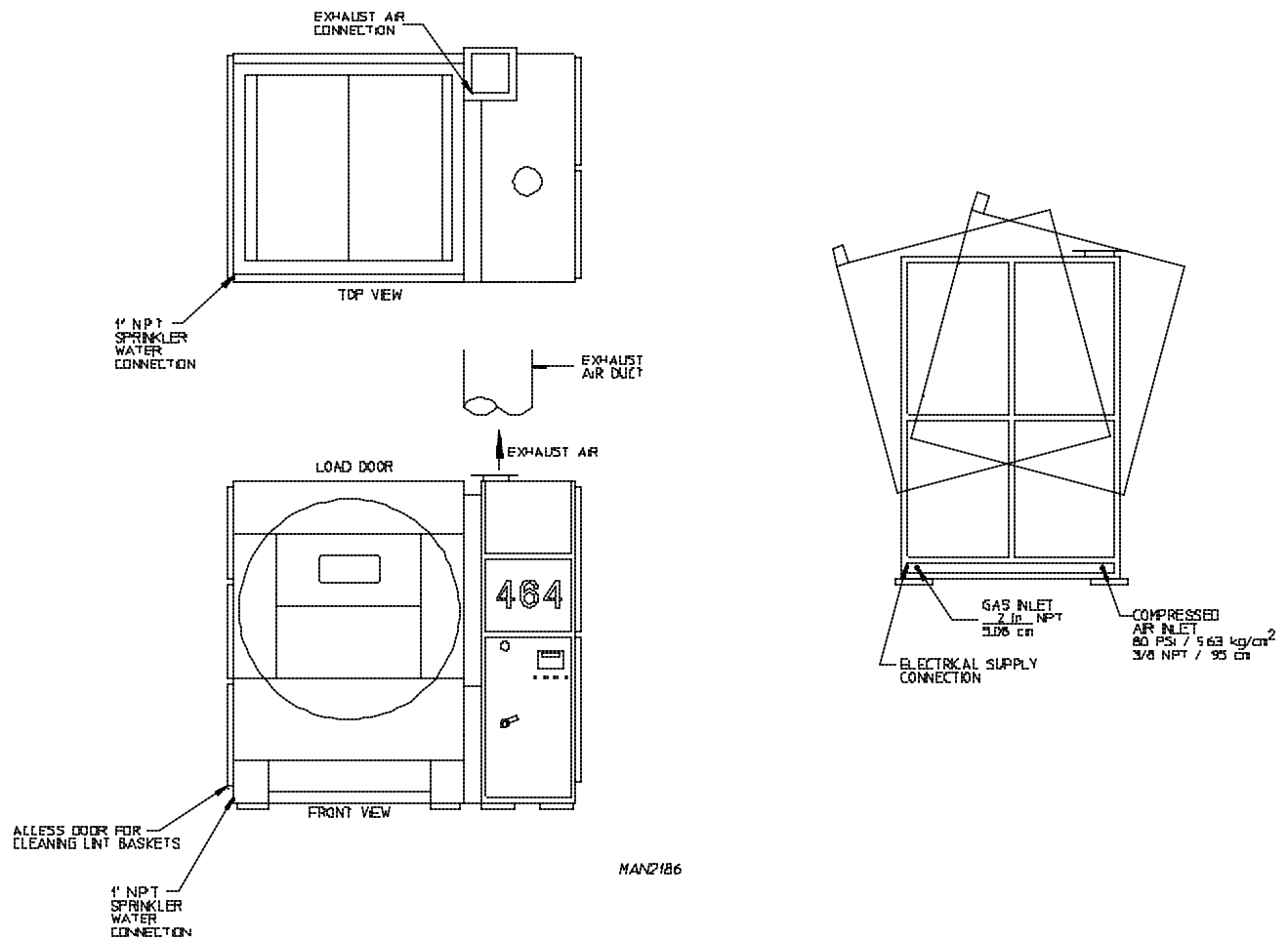

1. Optional Sprinkler Water Supply

A 40 PSI (2.75 bar) supply of water **must be** connected into the 1" N.P.T. sprinkler connection located on the left side of the tumbler (basket) base on dryer models with a sprinkler system.

2. Compressed Air Supply

A minimum of 20 cubic feet per hour (cfh) (.566 cu. m./hr) at 80 PSI (5.51 bar) of dry, clean and regulated compressed air **must be** supplied to the dryer.

The compressed air supply **must be** connected into the 3/8" F.P.T. fitting which is located in the rear corner of the lower heat console section.

3. Gas Piping

The gas connection to the dryer is made into the 2-inch F.P.T. shut-off valve located in the bottom front corner of the lower heat console.

The gas pressure supplied to the dryer **must be** between 7-inches (17.41 m bar) and 13-inches (32.34 m bar) water column (W.C.) for natural gas or between 10.5-inches (26.12 m bar) water column (W.C.) for L.P. (liquid propane) gas.

If the facilities gas pressure is higher than these values, an external pressure regulator **must be** installed prior to the dryer to reduce the gas pressure to within the appropriate range.

The dryer **must be** connected to either natural or L.P. (liquid propane) gas indicated on the dryer data label located on the inner right wall of the electric cabinet. If your gas supply does not match the type of gas for which the dryer was built, contact your distributor or the **ADC** factory.

1. The installation **must conform** with local codes or, in the absence of these local codes, with the *National Fuel Gas Code, ANSI Z223.1* or the *CAN.CGA-B149, Installation Codes*.
2. The dryer and its individual shutoff valve must be disconnected from the gas supply piping system during any pressure testing of that system at test pressures in excess of 1/2 psi (3.5 kPa.)

Pipe joint compounds that resist the action of natural and L.P. (liquid propane) gas **must be** used.

Test **ALL** pipe connections for leaks by brushing on a soapy water solution.

WARNING: NEVER TEST FOR LEAKS WITH A FLAME!!!

4. Exhaust Air Ducting

The dryer's exhaust air **must be** vented to the outdoors by the shortest route possible with the number of elbows kept to a minimum. The duct **should be** designed and installed by qualified technicians.

Improperly designed duct work reduce the airflow through the dryer, causing improper and unsafe drying conditions. The static pressure of the air in the duct work **must not exceed** 1.25-inch water column (3.1 millibar). The dryer exhaust 11,600 cfm (cubic feet per minute) - 328.5 cmm (cubic meters per minute) - of air during the drying cycle, 13,000 cfm (cubic feet per minute) - 368 (cubic meters per minute) - during cool down. Ducting **must be** sized for the 13,000 cfm 368 cmm (cubic feet per minute) of airflow.

The exhaust vent connection is located on top of the burner and heater section of the dryer. It has rectangle cross-section and is flanged.

A sheet metal transition piece is supplied to connect a 24-inch (60.96 cm) diameter exhaust duct to the dryers' exhaust vent connection. Care **must be** taken in locating this transition piece so that the tilting tumbler (basket) does not hit the transition piece.

The duct wire connecting the vent to the outdoors **must be** a minimum of 24-inches (60.96 cm) in diameter for a round duct or 625 square inches (15.87 square meters) for a rectangular duct (22-inches by 22-inches square duct [55.88 cm x 55.88 cm] would be sufficient).

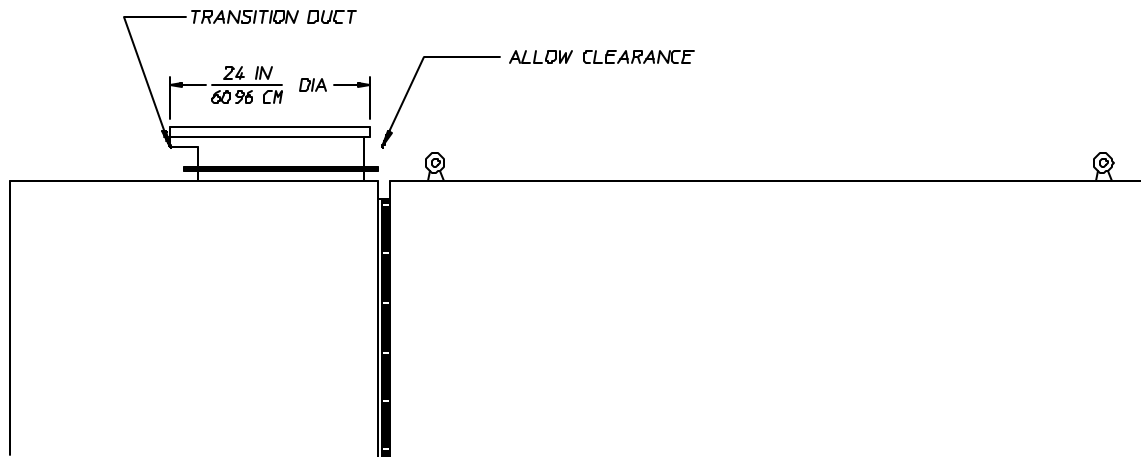

MAN4613

The duct work **must be** smooth on the inside with no projections from sheet metal screws or other obstructions which would collect lint. Inspection doors **must be** installed at strategic points in the duct work for periodic lint removal.

Use smooth sweeping elbows instead of sharp 90° elbows. The radius of an elbow **should be** at least 1-1/2 times the duct diameter.

When the exhaust duct goes through a combustible wall on a roof, leave a 2-inch (5.08 cm) clearance space between the exhaust ducting and the wall or roof.

When adding ducts, the duct that leaves the building **must be** protected from the weather. For horizontal ducting use a 90° turned downward. For vertical duct work use a 180° turned downward. In either case, allow at least twice the diameter of the duct between the duct opening and nearest obstruction. (If the duct is rectangular, leave twice the smallest face dimension.)

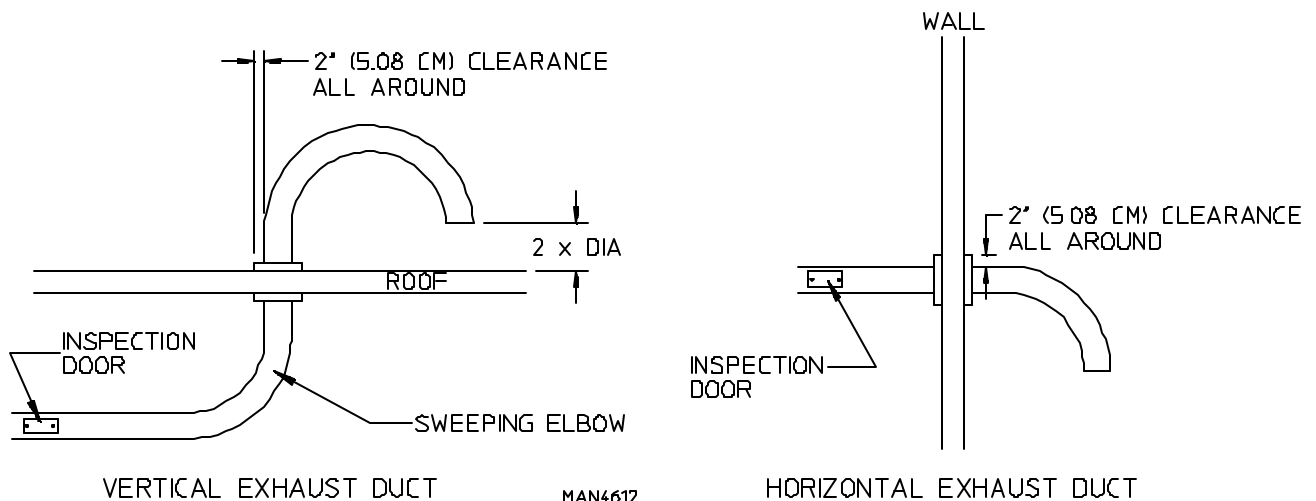

IMPORTANT: *DO NOT* use screen or caps on the outside opening of the exhaust duct work. Screens will clog with lint and caps will restrict the exhaust airflow.

E. ELECTRICAL REQUIREMENTS

1. Electrical Requirements

It is your responsibility to have **ALL** electrical connections made by a properly licensed and competent electrician to assure that the electrical installation is adequate and conforms with local and state regulations or codes. In the absence of such codes, **ALL** electric connections, materials and workmanship **must confirm** to the applicable requirements of the National Electrical Code ANSI/NFPA NO. 70-LATEST EDITION or in Canada, the CANADIAN ELECTRICAL CODES PARTS 1 & 2 CSA C22.1-1990 or LATEST EDITION.

IMPORTANT: Failure to comply with these codes or ordinances or requirements stipulated in this manual can result in personal injury or component failure.

NOTE: Component failure due to improper installation will VOID THE WARRANTY.

Each dryer **should be** connected to an independently protected branch circuit. *The dryer must be connected with copper wire ONLY. DO NOT use aluminum wire which could cause a fire hazard.* The copper conductor wire or cable **must be** of proper ampacity and insulation in accordance with electric codes for making **ALL** service connects

NOTE: The use of aluminum wire will VOID THE WARRANTY.

2. Electrical Service Specifications

ADG-464

ELECTRICAL SERVICE SPECIFICATIONS (PER DRYER)

IMPORTANT: 208 VAC AND 240 VAC **ARE NOT THE SAME**. When ordering, *specify exact voltage*.

NOTES:

- A. When fuses are used they **must be** dual element, time delay, current limiting, class RK1 or RK5 **ONLY**. Calculate/determine correct fuse value, by applying either local and/or National Electrical Codes to listed appliance amp draw data.
- B. Circuit breakers are thermal-magnetic (industrial) motor curve type **ONLY**. For others, calculate/verify correct breaker size according to appliance amp draw rating and type of breaker used.
- C. Circuit breakers for 3-phase (3Ø) dryers **must be** 3-pole type.

SERVICE VOLTAGE	PHASE	WIRE SERVICE	APPROX. AMP DRAW		MINIMUM WIRE SIZE	FUSING	CIRCUIT BREAKER
			60 Hz	50 Hz		Dual Element Time Delay	
208	3Ø	3/4	107	--	*	150	150
240	3Ø	3	104	109	*	150	150
380	3Ø	3/4	--	60	*	90	90
400	3Ø	3/4	--	60	*	90	90
416	3Ø	3/4	--	57	*	90	90
460	3Ø	3/4	52	--	*	80	80
480	3Ø	3/4	52	--	*	80	80

* AWG Stranded Wire Type...size wire as per National Electrical Code or local codes.

IMPORTANT: The dryer **must be** connected to the electric supply shown on the data label that is affixed to the right side of the main electrical enclosure. In the case of 208 VAC or 240 VAC, the supply voltage **must match** the electric service specifications of the data label *exactly*.

WARNING: 208 VAC and 240 VAC **ARE NOT THE SAME**. Any damage done to the dryer components due to improper voltage will automatically **VOID THE WARRANTY**.

IMPORTANT: For proper sprinkler and dryer operation, sprinkler **must be** powered by a “separate or dedicated” single-phase (1Ø) multi-wire branch circuit at dryer’s nameplate voltage.

NOTE: For 4-wire service, cap the neutral.

NOTE: Contact the factory for electrical information not listed.

NOTE: ADC reserves the right to make changes in specifications at any time, without notice or obligation.

3. Electrical Service

The electrical power is connected the dryer at the high voltage section of the control cabinet. On the ADG-464 dryer, this section is located at the bottom left of the main electrical enclosure.

The ADG-464 dryer **must be** supplied with two (2) independent input power lines. One is 3-phase (3 ϕ) electric service that feeds the dryer itself, and the other is 1 ϕ electric service that feeds the safety sprinkler system. *Both input lines must be independent of each other and individually protected by their individual fused disconnect.*

NOTE: The ADG-464 with sprinkler option **will not operate** without an independent power source fed to the Safety Sprinkler System.

Feed the electrical service cables to the dryer using the pre-punched knockouts at the bottom section of the electrical cabinet right wall.

Connect the ground wires directly to the ground lug located at the same approximate area.

NOTE: The sprinkler operates off of single-phase (1 ϕ) nameplate voltage of the dryer.

Before turning power on to the dryer, measure the supply voltage to ensure that it matches the dryer's specified input voltage. This input voltage is marked on the aluminum data plate located on the inner right wall of the electrical cabinet.

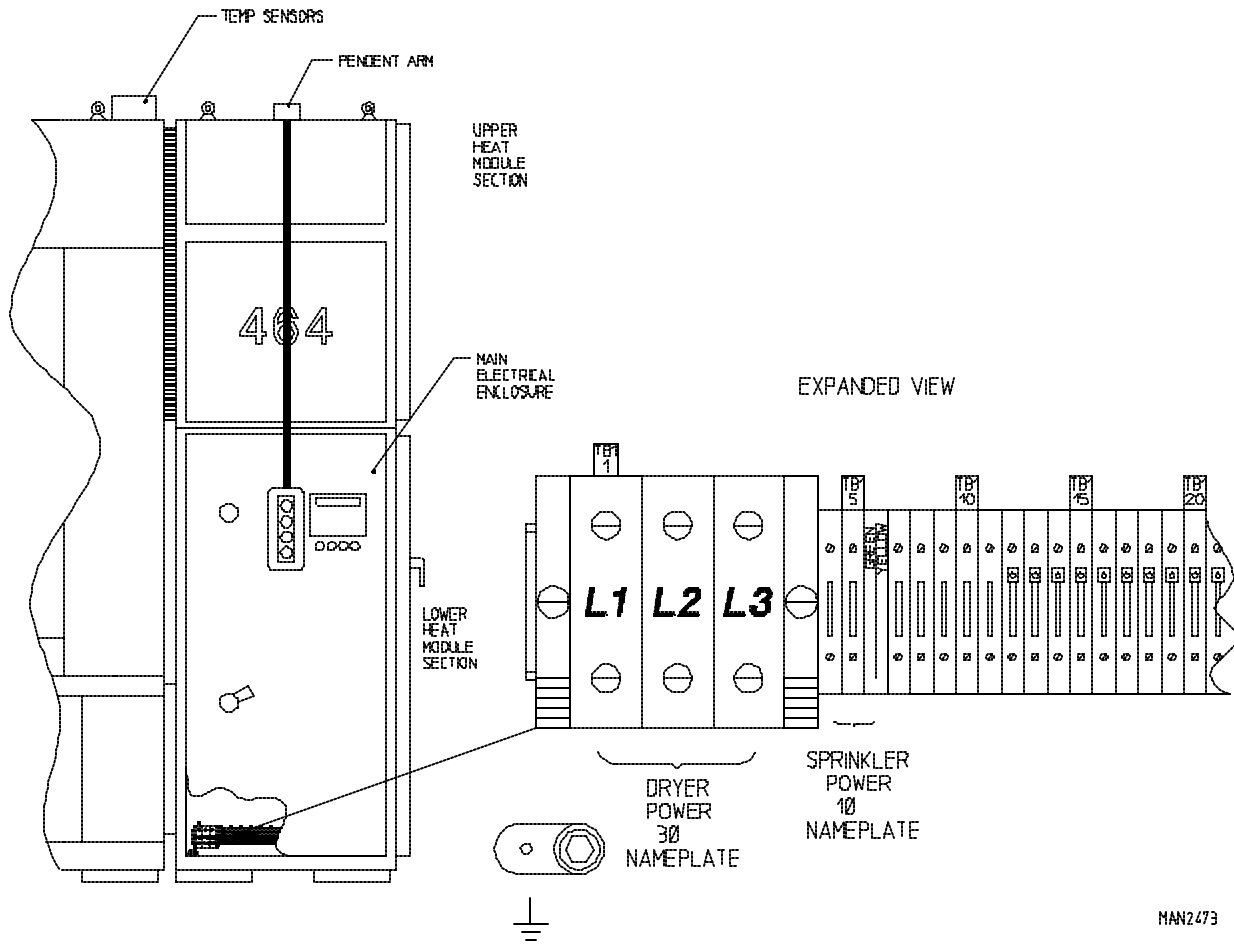

F. FRESH AIR SUPPLY REQUIREMENTS

When the dryer is operating, it draws in room air, heats this air through the tumbler (basket), and exhausts it out of the building. Therefore, the room air **must be** continually replenished from the outdoors. If makeup air is inadequate, drying time and efficiency will be adversely affected, and safety will be compromised. Premature component failure may result.

Air supply (make-up air) **must be** given careful consideration to assure proper performance of each dryer. An unrestricted source of air is necessary for each dryer. An airflow of 13,000 cfm per minute (368 cmm) (cubic meters per minute) **must be** supplied to each dryer. As a general rule, an unrestricted air entrance from the outdoors (atmosphere) of a minimum twenty (20) square feet (6.096 m²) is required for each dryer.

To compensate for the use of registers or louvres used over the openings, the makeup air area **must be** increased by approximately thirty-three percent (33%). Makeup air openings **should not** be located in an area directly near where exhaust vents exit the building.

Allowances **must be** made for remote or constricting passageways or where dryers are located at excessive altitude or predominantly low pressure areas. The dryer **must be** installed with provisions for adequate combustion and make-up air supply.

IMPORTANT: Makeup air *must be* provided from a source free of dry cleaning solvent fumes. Makeup air that is contaminated by dry cleaning solvent fumes will result in irreparable damage to the motors and other dryer components.

NOTE: Component failure due to dry cleaning solvent fumes will VOID THE WARRANTY.

SECTION IV

PRE START-UP

A. PREPARATION FOR OPERATION

1. The supply voltage **must match** the dryer voltage as stated on the aluminum dryer data label which is located on the inner right wall of the electrical cabinet.
2. A separate fused power supply **must be** connected into safety sprinkler circuit power connection.
3. Open **ALL** steam supply lines and condensate return line shut-off valves.
4. A compressed air supply of 80 PSI (5.51 bar) **must be** connected into the dryer's fitting located at the rear corner of the lower heat console section.
5. The dryer exhaust duct **must be** vented to the outdoors.
6. A water supply of 40 PSI (2.75 bar) **must be** connected into the 1-inch sprinkler pipe connection.
7. The dryer **must be** lagged to the floor and leveled for proper operation.
8. A fresh air supply from the outdoors of 13,000 cfm (368 cmm) **must be** available to the dryer.
9. **ALL** service doors **must be** closed and all access panels and tilt guards **must be** installed on the dryer.

SECTION V

ROUTINE MAINTENANCE

A. CLEANING

A program or schedule **should be** established for periodic inspection, cleaning, and removal of lint from various areas of the dryer, as well as throughout the duct work system. The frequency of this cleaning can best be determined from experience at each location. Maximum operating efficiency is dependent upon proper air circulation. The accumulation of lint can restrict this air flow. If the guidelines in this section are met, an ADC dryer will provide many years of efficient, trouble free and safe operation.

WARNING: LINT FROM MOST FABRICS IS HIGHLY COMBUSTIBLE. THE ACCUMULATION OF LINT CAN CREATE A POTENTIAL FIRE HAZARD.

WARNING: KEEP DRYER AREA CLEAR AND FREE FROM COMBUSTIBLE MATERIALS, GASOLINE AND OTHER FLAMMABLE VAPORS AND LIQUIDS.

NOTE: Suggested time intervals shown are for average usage which is considered six (6) to eight (8) operational (running) hours per day.

NOTE: Remove power from the machine before performing any maintenance in the machine (cleaning the lint drawers and both steam coil lint screens are the only exceptions).

IMPORTANT: Dryer produces combustible lint and *must be* exhausted to the outdoors. Every 6 months, inspect the exhaust ducting and remove any lint build up.

SUGGESTED CLEANING SCHEDULE

EVERY THIRD OR FOURTH LOAD

Clean lint accumulation for lint drawers.

Clean lint accumulation from the burner lint screens.

NOTE: The frequency of cleaning the lint screens can best be determined from experience at each location.

WEEKLY

Clean any lint accumulation from inside the heat console.

WARNING: TO AVOID THE HAZARD OF ELECTRICAL SHOCK, DISCONTINUE ELECTRICAL SUPPLY TO THE DRYER.

MONTHLY

Grease the four (4) tumbler shaft pillow bearings with DC-44 (Dow Corning) grease or equivalent. DC-44 is a lithium grease that conforms to NLGI Grade 2 and has a temperature range of 40° F (4.4° C) to 400° F (204.4° C).

Empty the compressed air filter bowl and add oil to the compressed air lubricator bowl. Use a petroleum based non-detergent lightweight oil, SAE 10/150SSU, which will readily break up into a mist, such as Mobil DTE Light Oil or equivalent. **DO NOT USE SYNTHETIC OILS.**

EVERY 90 DAYS

Clean any lint accumulation on main blower wheel.

Remove lint from around the tumbler drive motors and main blower (fan) motor.

Main blower (fan) shaft bearings **must be** lubricated. Use a #3 grease or equivalent.

EVERY 6 MONTHS

Remove the gear oil in both tumbler drive shaft gear reducers. Replace with 1.4 liters (in each gear reducer) of Mobil Oil DTE HH5G (I.S.O. viscosity grade 460) or equivalent.

Main blower fan and drive motor belts **should be** examined. Cracked or seriously frayed belts **should be** replaced. Tighten belts when necessary.

Inspect and remove lint accumulation in customer furnished exhaust duct work system.

Open access door on top of tumbler and remove lint accumulation from tumbler brush.

NOTE: THE ACCUMULATION OF LINT IN THE EXHAUST DUCT WORK CAN CREATE A POTENTIAL FIRE HAZARD.

NOTE: When cleaning the dryer cabinets, avoid using harsh abrasive. A product intended for the cleaning of appliances is recommended.

SECTION VI

COMPONENT SYSTEM DESCRIPTIONS

A. TUMBLER (BASKET) SUPPORT and DRIVE SYSTEM

IMPORTANT: Always keep the tumbler (basket) section of the dryer in an upright position when moving it.

1. Tumbler (Basket)

The tumbler is made of five (5) 14-gauge stainless steel perforated panels, five (5) stainless steel lifting ribs, and two (2) outer tumbler rings. The tumbler (basket) is a completely welded assembly so the perforated panels are not removable.

2. Tumbler (Basket) Support System

The tumbler (basket) sits on four (4) 11-inch diameter heavy-duty rubber roller wheels which supports and drives the tumbler. The rubber wheels are molded into each of four (4) steel hubs. The steel hubs are fastened to the 2-inch diameter drive shafts by taper lock bushings. Each drive shaft is supported by two (2) 2-inch diameter heavy duty roller bearings. The position of the tumbler (basket) is adjusted by moving these bearings in or out with the four (4) bearings adjustment bolts.

AD - 464 TUMBLER DRIVE SYSTEM

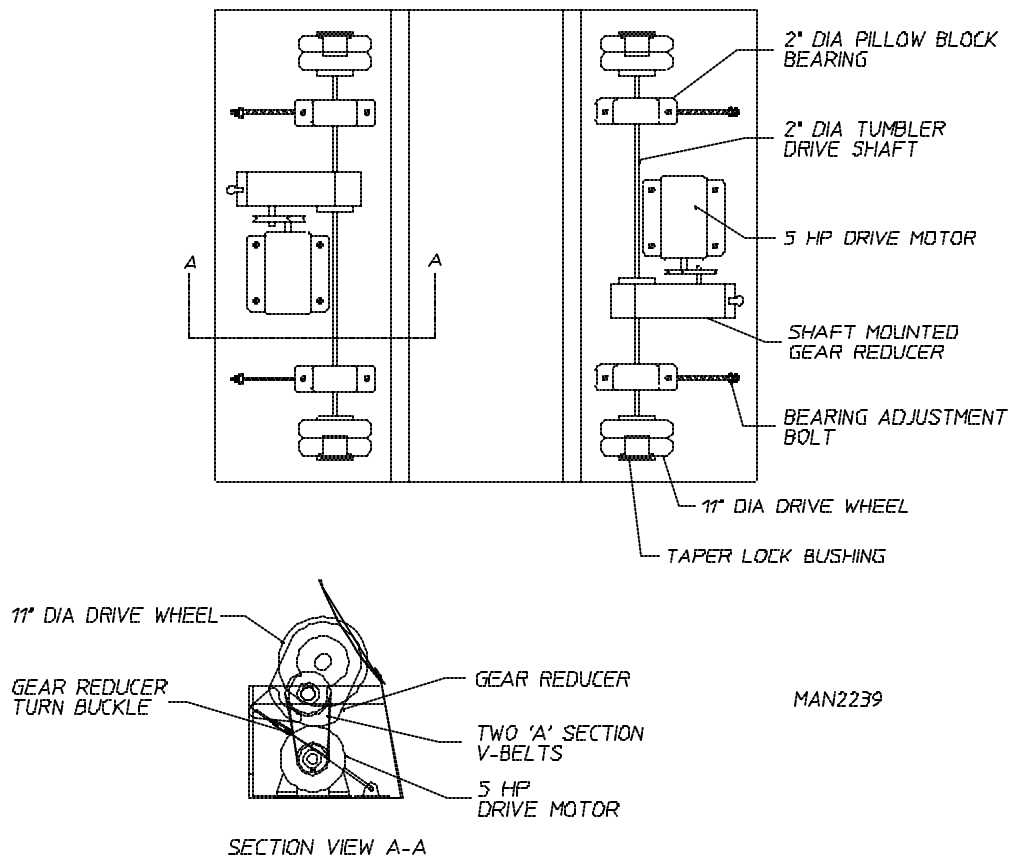

3. Tumbler and Basket Drive System

There are two (2) 5 HP tumbler drive motors. Each motor drives one of the 2-inch diameter tumbler drive shafts, and the motors spin simultaneously so that all four (4) sets drive wheels work together to spin the tumbler (basket).

Each motor is connected to the drive shaft by two (2) "A" section V-belts, driving a shaft-mounted (5.6 to 1 ratio) gear reducer. This produces a tumbler shaft speed of 200 RPM to 205 RPM and a tumbler (basket) speed of 31.5 RPM. Proper tension is maintained on the V-belts by tightening the gear reducer turnbuckle support. The oil in each gear reducer **must be** replaced every six (6) months by 1.4 liters of I.S.O. viscosity Grade 460 gear oil.

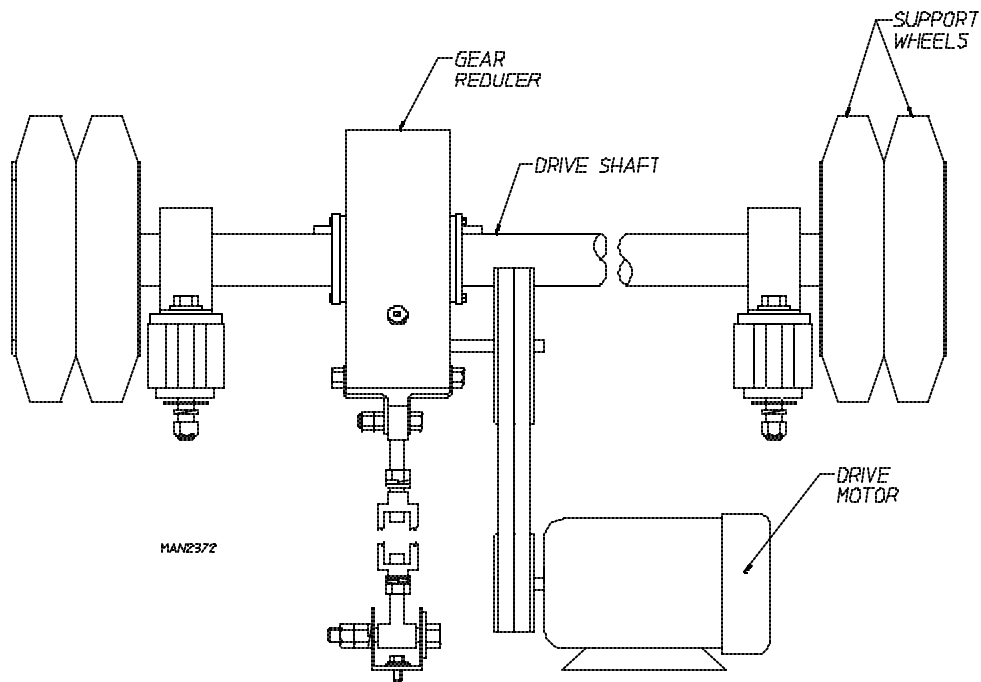

4. Servicing the Drive System

a. Removing a Drive Wheel

The drive wheels are removed through the front and back panels of the dryer, **not through the slides**. The front loading door and back loading door panels are hinged at the top. Remove the bolts holding these panels to tumbler section frame and swing the panel out. The two (2) 1/4-inch poly-flo tubes connected to the load door piston have to be removed to allow the panel to swing up far enough out to get access to the drive wheels. Likewise, the following electrical disconnections **must be** performed (refer to page 31).

1) Front Panel Electrical Connections:

a) Front Position Switch Disconnect Plug;

The front door position switch disconnect plug is located on the left side of the front doors. Disconnect this plug and feed the cable through the right hand side of the tumbler section.

b) Intake Temperature Probe Disconnect Plug;

The intake temperature probe disconnect plug is located in the burner and heater section, just above the 25 HP motor. Disconnect this plug and route through the hole located on the right of the front panel.

2) Rear Panel Electrical Connection Plug;

a) Rear Panel Controls Disconnect Plug;

The rear panel controls disconnect plug is located behind the rear panel controls. Disconnect this plug and feed through hole towards the left hand drum motor section.

b) Rear Door Position Switch Disconnect Plug;

The rear door position switch disconnect plug is located on the left side of the rear doors. Disconnect this plug and feed the cable through the right hand side of the tumbler section.

Put a block of wood under the tumbler; loosen and back out the tumbler shaft support bearings so that the drive wheel lines up with the large hole in the frame. The drive wheel taper lock bushing can now be loosened and removed through the hole in the frame, and the drive wheel pulled out of the dryer through this hole. Before backing out the tumbler shaft bearings mark their position on the frame to make reassembly easier.

5. Tumbler (Basket) Retaining Wheels

There are eight (8) 4-7/16 diameter retaining wheels which stabilize the tumbler's (basket's) position from front to back. Four (4) of these are mounted on the front panel of the dryer (two [2] on the left side and two [2] on the right side), and four (4) are mounted on the rear panel (two [2] on the left side and two [2] on the right side). Access to these wheels is obtained by removing the vertical front and rear panel covers.

B. MAIN AIR BLOWER and HEAT RECLAIMER SYSTEM

The fan which moves the exhaust air through the ADG-464 dryer is a 22-inch diameter, squirrel cage wheel that is driven at 1,100 rpm by a 25 HP motor. This fan moves a maximum of 13,000 cfm (368 cmm) air through the dryer.

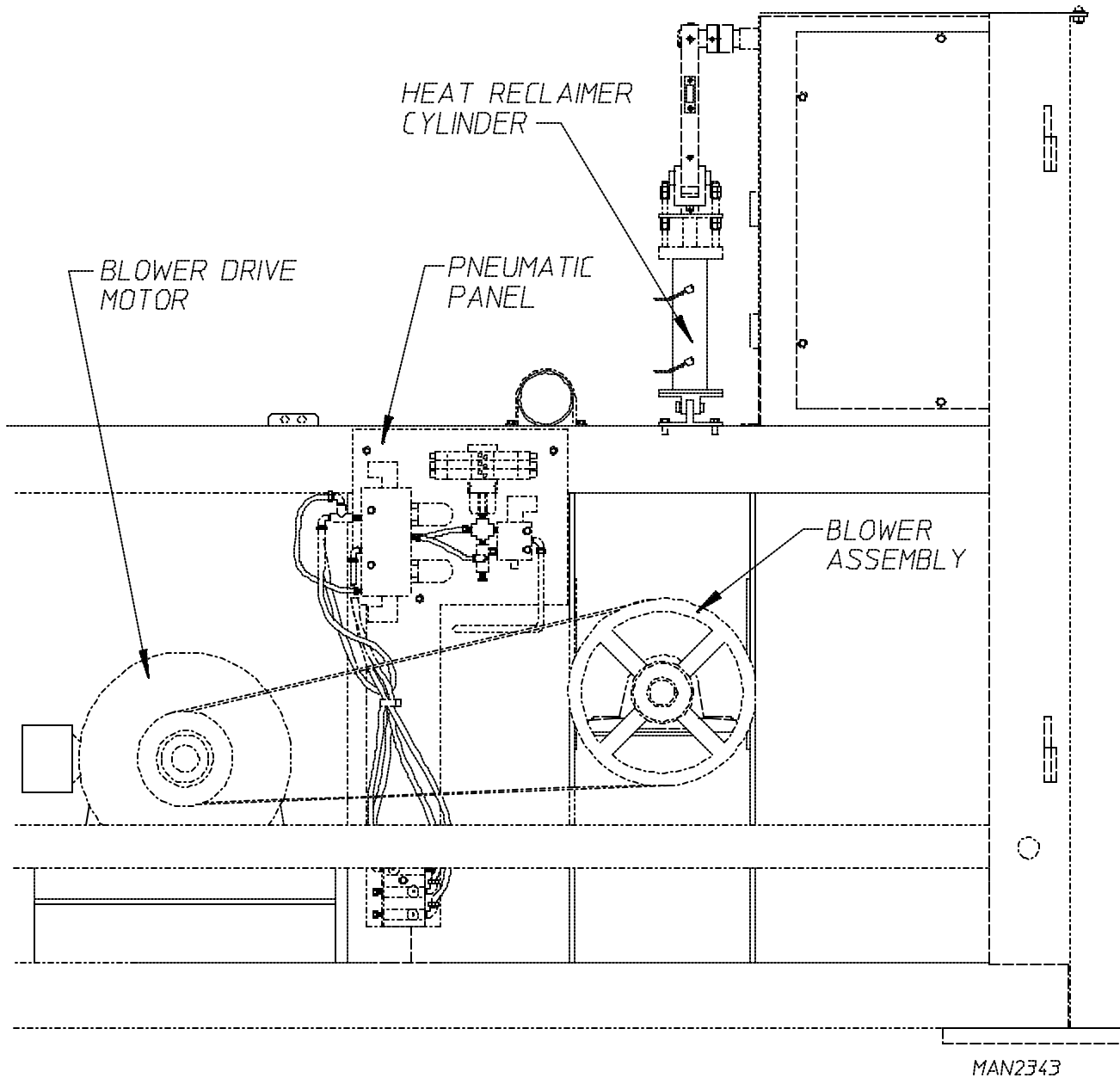

The dryer is equipped with a pneumatically operated heat reclaimer damper, which when opened, will recirculate approximately fifteen percent (15%) of the dryer's exhaust air.

The heat reclaimer damper is closed until ignition of flame has been established. Then, the damper piston is actuated, opening the dampers recirculating fifteen percent (15%) of the exhaust air back over the gas burner and into the tumbler (basket). The damper remains open for the rest of the drying cycle. On cool down, the damper closes, exhausting **ALL** of the 13,000 cfm (368 cmm) which ensures a fast cool down of the load.

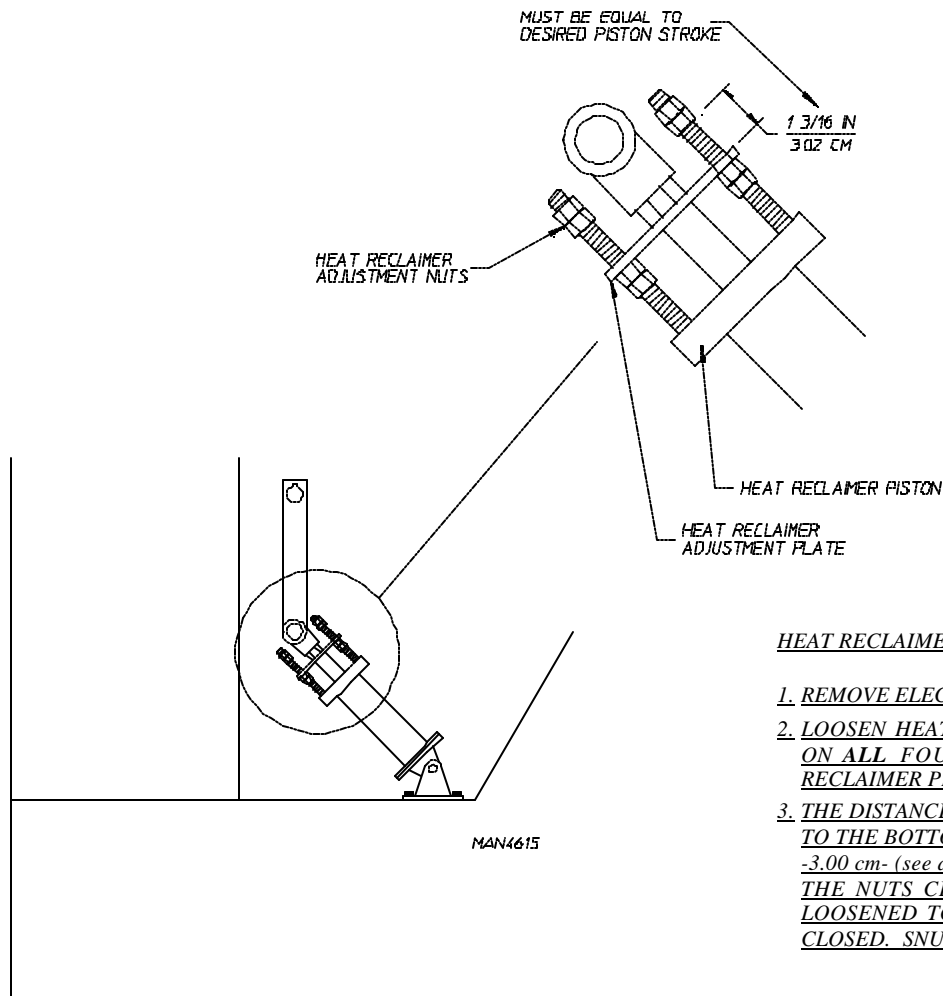

HEAT RECLAIMER ADJUSTMENT

1. REMOVE ELECTRICITY FROM THE UNIT.
2. LOOSEN HEAT RECLAIMER ADJUSTMENT NUTS ON ALL FOUR (4) CORNERS OF THE HEAT RECLAIMER PISTON.
3. THE DISTANCE BETWEEN THE TOP OF THE PLATE TO THE BOTTOM OF THE NUTS MUST BE 1-3/16" -3.00 cm- (see drawing below) IN ORDER TO OBTAIN THE NUTS CLOSEST TO THE PISTON MUST BE LOOSENED TO ONE PISTON WITH THE DAMPER CLOSED. SNUG THE NUTS UP TO THE PLATE.
4. TIGHTEN TOP HEAT RECLAIMER NUTS DOWN ONTO THE BOTTOM HEAT RECLAIMER NUTS.

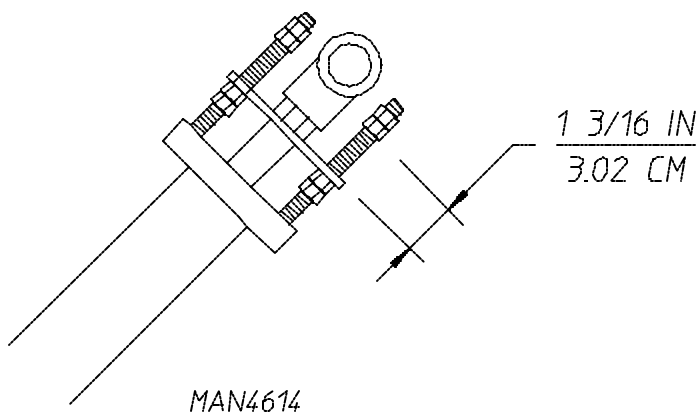

C. COMPRESSED AIR SYSTEM

The compressed air system of the ADG-464 dryer consists of a number of pneumatic pistons located throughout the dryer, an FRL (Filter/Regulator/Lubricator) assembly, and pneumatic control panel.

1. Air Pistons:

The pistons are actuated by solenoid and flow control valves that are under computer control. The pneumatic pistons are used to:

- Tilt the dryer for loading and unloading.
- Open and close load and unload doors.
- Operate heat reclaimer.
- Operate the cool down damper and the intake air damper.

2. Filter/Regulator/Lubricator (FRL) Assembly

The compressed air supply to the dryer is connected into the 3/8-inch F.P.T. fitting located on the rear corner of the lower heat console. This is connected to the FRL (Filter/Regulator/Lubricator) assembly which is located at the bottom rear of the lower heat console section.

The FRL (Filter/Regulator/Lubricator) assembly performs three (3) functions;

- a. The filter removes most solids and liquid particles from the compressed air stream and traps them in its bowl where this waste can be readily removed through the drain valve at the bottom of the bowl.

The filter bowl **should be** cleaned monthly.

CURRENT PRODUCTION

PAST PRODUCTION

- b. For dryers manufactured prior to February 26, 1997 ..

The lubricator injects a mist of oil into the compressed air stream so that the pistons and solenoid valves will function smoothly.

The oiling rate can be adjusted by turning the oil adjustment screw on top of the lubricator.

Oil is added to the bowl **should be** refilled on a monthly basis with any petroleum-based, non-detergent lightweight oil (SAE 10/150 SSU) which will readily break up into a mist. **DO NOT USE SYNTHETIC OIL or OILS CONTAINING ADDITIVES or SOLVENTS.**

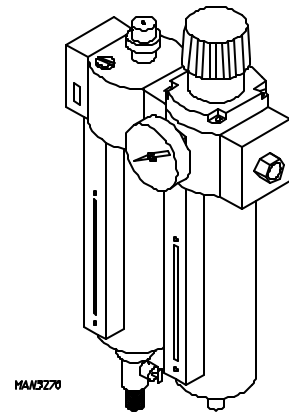
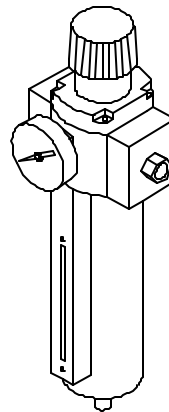

- c. The regulator will maintain a nearly constant outlet air pressure of 80 PSI (5.51 bar) so that the dryer's air pistons will function normally despite upstream air pressure variation.

NOTE: For complete operation and maintenance information on the Filter/Regulator/Lubricator (FRL) assembly, refer to the manufacturer data sheets accompanying this manual.

Dryers manufactured as of February 26, 1997 have their pneumatic components pre-lubricated.

3. Pneumatic Control Panel

The pneumatic control panel of a two-way tilt dryer has two (2) tilting solenoid valves, one to control the front set of tilting pistons and a second to control the rear set of tilting pistons. A 1-Way Tilt dryer has only one (1) tilting solenoid valve.

Each valve has five (5) 1/2-inch F.P.T. ports and two (2) electric solenoids, one on each side of the valve.

To tilt the dryer back, a 120 volt signal is applied to the front pistons solenoid connector #S5, and no voltage is applied to the solenoid connector #S8. The internal spool in the valve will move and 80 PSI (5.51 bar) of air will enter the bottom port of the front tilting pistons, extending the front tilting piston rods and tilting the dryer back for loading. The top piston ports are bled to the atmosphere. To level the dryer after loading, the voltage signals are reversed. No voltage is applied to the "S5" solenoid, and 120 volts are applied to the "S8" solenoid. The valve spool will now move so that 80 PSI (5.51 bar) of air is applied at the top piston ports, while the bottom piston ports are bled to the atmosphere. The piston rods will now retract, leveling the dryer. On 2-Way Tilt dryers, the rear tilting piston solenoid valve acts in the same manner.

The tilting piston valves are 3-position valves. This means that, if no voltage is applied to both positions "S5" and "S8" **ALL** five (5) valve ports are blocked. If the dryer is tilting or leveling and power to the dryer is shut off, the pistons will lock in position, holding the dryer in a partially tilted position.

The dryer can be made to tilt faster or slower by adjusting the pistons 3/8" flow control valves which are located on the pneumatic control panel.

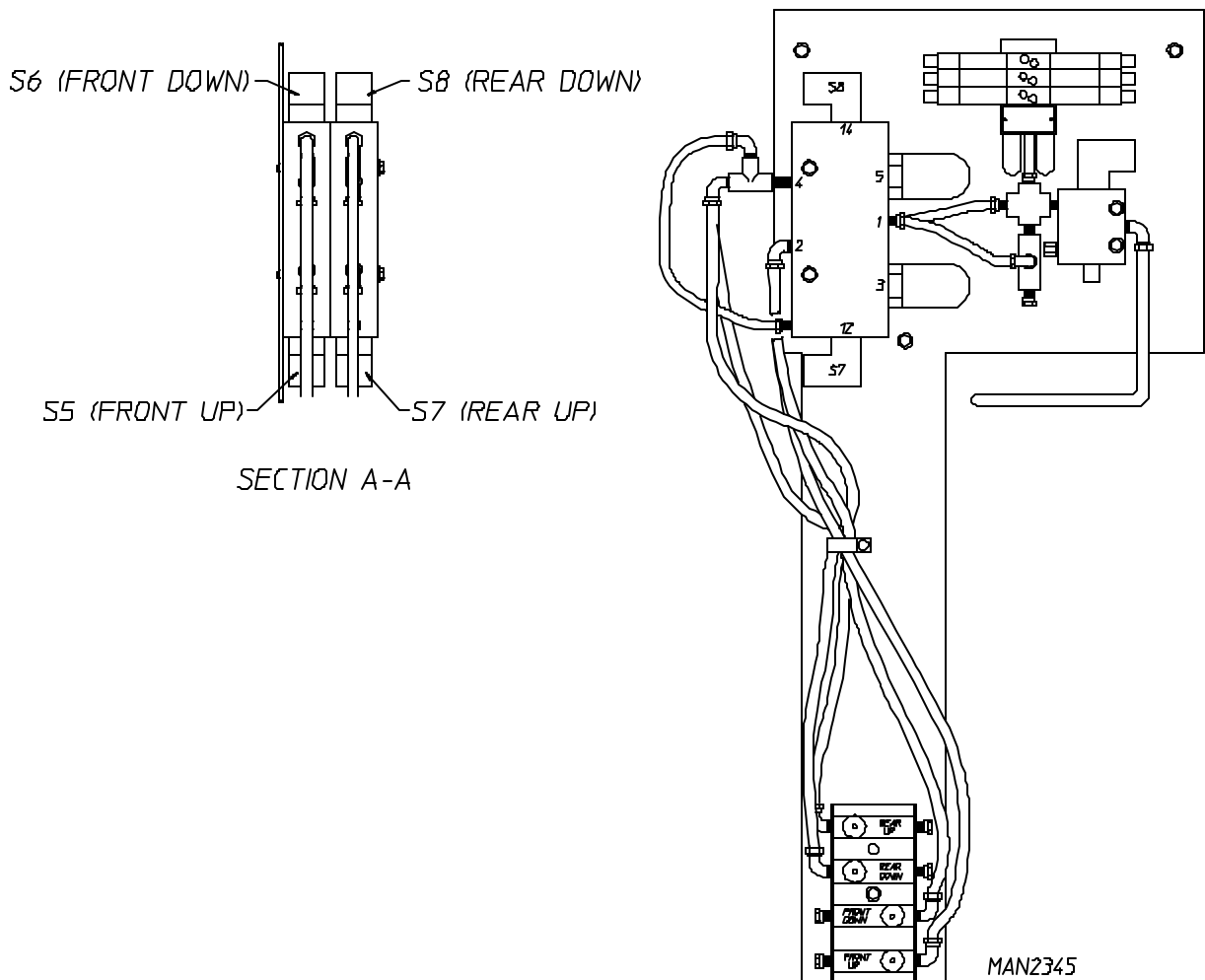

4. Internal and External Pilot Air Supply

On two-way tilt dryers, a pneumatic safety circuit is incorporated to prevent both front and rear tilting pistons from extending their rods at the same time. When 120 volts is supplied to the “S5” side of the front tilting piston solenoid valve coil, the round internal spool in the core of the solenoid will move, allowing 80 PSI (5.51 bar) air to flow into the bottom ports of the front tilting pistons, while the top ports of these pistons are bled to the atmosphere. In addition to this 120 volt electrical signal, the spool also requires a 30 PSI (2.06 bar) supply of compressed air to change its position. This pilot air can either be supplied internally, tapped off the 80 PSI (5.51 bar) air supply connected to port no.1 through holes in the body of the solenoid valve or it can be supplied externally through the 1/8-inch F.P.T. connection located on either end of the solenoid valve. If no pilot air is supplied to the solenoid valve. Then the spool **cannot** move, even with voltage supplied to the solenoid valve coil.

This can be used to prevent both sets of tilting pistons from extending their rods at the same time. When the front tilting piston rods are extended, 80 PSI (5.51 bar) air is connected to the bottom piston ports, while the top piston ports are bled to the atmosphere. So, by tapping the external pilot air supply to the rear tilting rods are extended, then there is no pilot pressure available to the rear tilting piston solenoid valve so that its spool **cannot** move and the rear tilting piston rods **cannot** extend if a 120 volt signal is sent to its “12” side solenoid valve coil.

The external pilot air supply to the front tilting piston is tapped off the rear tilting piston top port air line so that whenever the rear piston rods are extended, there is no pilot air supplied to the front tilting piston solenoid valve and the front tilting piston rods cannot extend. On the solenoid valve supplied on the dryer, the “12” side valve is externally piloted, while “14” side valve is internally piloted.

A valve can easily be checked for internal or external piloting by removing the two (2) screws which hold the solenoid operator onto the valve. For an internal pilot air to be supplied to the valve spool. For an external pilot, the solid sealing disc **must be** positioned on top of the internal port.

5. Loading Doors and Heat Reclaimer, Cool Down and Intake Air Damper

These solenoid valves are located in the 6-station manifold block on the pneumatic control panel. Each door piston is controlled by two (2) 2-port/2-position solenoid valve. The heat reclaimer is controlled by one (1) 2-port/2-position solenoid valves.

The three (3) pistons that control the heat reclaimer damper, cool down damper, and intake air damper are controlled by a single 3-way double acting solenoid valve.

To open the front loading door, a 120 volt signal is applied to “S1,” the coil of the valve that supplies air to the load door or the heat reclaimer’s bottom port. The valve will open, and 80 PSI (5.51 bar) of air is supplied to the bottom port of the piston. The piston rod will extend, and the door will open. No voltage is applied to “S2,” the coil of the valve that controls the air supply to the door pistons top port so that this line is bled to the atmosphere.

To close the front loading door or heat reclaimer damper, the voltage signals are reversed, and the loading door will close.

D. GAS BURNER and IGNITION SYSTEM

The ADG-464 dryer gas burner system operates an on/off gas rate sequences to accurately control the tumbler's (basket's) drying temperature. Maximum firing rate is 2,800,000 Btu/hr (705,588 kcal/hr).

Upon a call from heat, the dryer computer sends a 120 volt signal to the burner controller module (BCM) which initiates and controls the ignition sequences. The burner controller module (BCM) insures that **ALL** the safety switches are closed before turning on the combustion air burner fan, then checks to ensure that the burner fan air switch has closed. The pilot gas flame is then established, the flame rod (which sits in this pilot flame) comes in contact with the flame and signals the BCM. The main motorized gas valves open in sequence and full operational flame is achieved.

The burner controller module (BCM) has five (5) LED's (light emitting diodes) on its cover and two (2) neon's on the mounting base for ease of troubleshooting, as well as dip switches inside for ease of programming.

The burner controller module (BCM) controls **ALL** of the gas burner ignition components, except for the motorized gas valve. When the drying set point temperature is reached, the dryer's computer closes the top motorized gas valve, shutting off full flame.

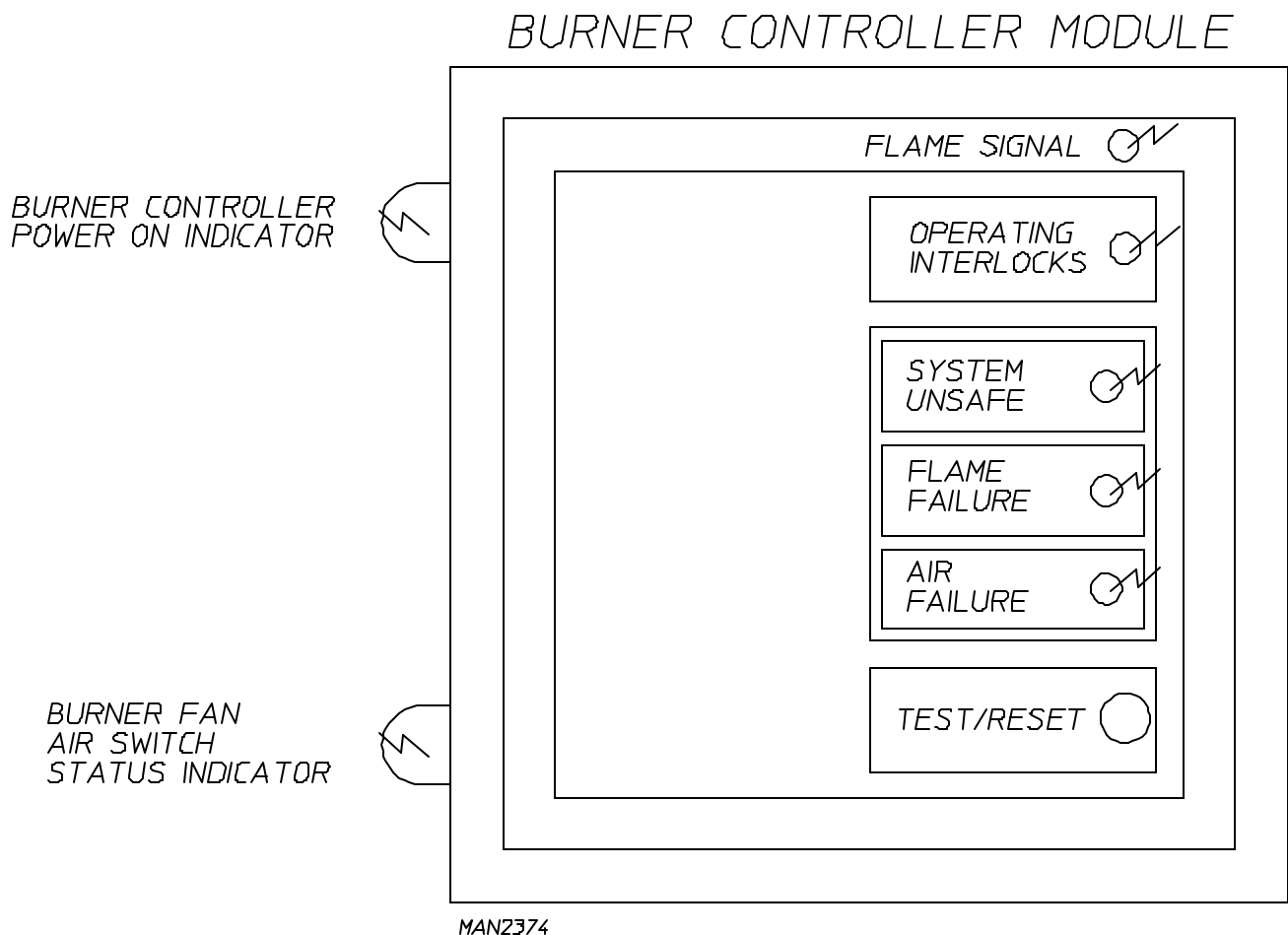

1. Major Burner Components

a. Burner Controller Module (BCM)

The BCM (burner controller module) provides effective burner flame safeguard control through adjustable purge and trial-for-ignition timing. The BCM insures that **ALL** dryer safety switch circuits are closed, delays ignition to allow the combustion chamber to vent, and insures that a healthy pilot flame is established before opening the main gas valves. Five (5) LED's (light emitting diodes) on the cover of the BCM allow for easy troubleshooting. Dip switches on the back of the module allow for easy programming.

1) Dip Switches Selections

- a) Loosen the two (2) screws on the burner control module cover and pull the module cover off of its base. The dip switches are on the back of the cover.

Switch #1 - Recycling Mode

With this switch in the "ON" position, the burner will recycle the ignition sequence once during each drying cycle after a burner fan air switch or main flame failure, but only if the failure occurs more than 35-seconds after ignition. If this switch is "OFF", the burner will lock out at once.

Switch #2 - Intermittent Pilot

This switch is "ON" for intermittent pilot or "OFF" for interrupted pilot. **ADC** utilizes intermittent pilot so that the pilot flame stays lit during the entire drying cycle. With interrupted pilot, the pilot flame would go out once the main flame is established. This is used mainly on oil burners lit by a gas pilot.

Switch #3 - Trail-for-Ignition (TFI) Time

When this switch is "ON" a trial-for-ignition TFI of ten (10) seconds is set. If it is in the "OFF" position, the (TFI) is 5-seconds. The trial for Ignition time is the length of time that the pilot is given to light. A 10-second TFI is best for the dryer.

Switch #4, Switch #5, Switch #6, Switch #7, Switch #8 - Purge Time

Switch #8 is in the "ON" position, and switch #4, switch #5, switch #6, and switch #7 are in the "OFF" position. This gives a purge time of 0-seconds.

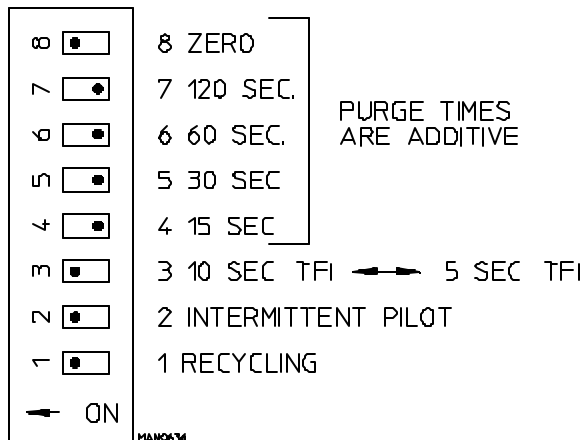

2) L.E.D. (light emitting diode) and Neon Displays of the BCM (Burner Controller Module)

a) Operating Interlock - L.E.D. (light emitting diode) is lit when:

ALL safety interlock switches are closed applying a 120 VAC signal to terminal #7 of the burner controller module (BCM).

b) Operating Interlock - L.E.D. (light emitting diode) is not lit when:

One or more safety interlock switches are open. If any safety interlocks switch is open the burner ignition sequence will not be attempted.

c) Air Failure - L.E.D. (light emitting diode) is lit if:

- Air switch is not closed within 10 seconds of start-up of blower
- Air switch is open during firing cycle.

d) System Unsafe - L.E.D. (light emitting diode) is lit if:

- A dryer safety device, connected in series with terminal #7, is opened. These safety devices include the door switches, tilt switches, tumbler (basket) stop motion detector, high temperature limit switches, airflow switches, and high or low gas pressure switch.
- A loose connection on the flame rod or spark plug.
- ALL purge time dip switches are in the off position.
- Flame is detected out of sequence.
- Inductance (H) is detected on sensor wires.
- Wiring fault on terminal #3, terminal #4, and terminal #5.
- Internal controller failure.
- Air switch closed before start-up.

e) Flame Signal - L.E.D. (light emitting diode) is lit when:

The flame rod is in contact with the pilot flame and the BCM (burner controller module) converts a microampere (μ) current between the flame rod and ground into a 3 volt DC to 11 volt DC signal that can be measured on the BCM. Insert one (1) probe of a DC volt meter into the flame signal port and put the other probe to ground. The meter will read out the 3 volt DC to 11 volt DC flame signal. If the flame signal L.E.D. (light emitting diode) flickers on and off, this is a result of a weak flame signal which can be caused by an intermittent wiring connection between the flame rod and the BCM, a faulty ground connection, bad ground of the dryer, weak pilot flame, and dirty or defective flame rod.

f) Burner Controller Power On Indicator - Neon is lit when;

Burner controller has its supply voltage of 120 VAC.

g) Burner for Air Switch Status Indicator - Neon is lit when;

Air switch is closed after start-up of the blower (fan) and the interlocks are ALL closed.

h) Burner Fan Air Switch Status Indicator - Neon is not lit;

- Air switch is not closed after start-up of burner fan.
- Door interlocks are open.
- Combustion burner screen is clogged.
- A door on the dryer is open.

i) Test and Reset Button

When this button is pushed in, the burner controller module (BCM) will halt the ignition sequence, once the pilot flame is established. This allows the pilot flame to be adjusted.

3) Flame Rod and Spark Plug

The pilot flame is lit by the spark plug, while flame sensing is done through the flame rod. The spark plug is energized when the pilot solenoid valve opens, igniting the pilot flame. The flame rod sits in the pilot flame and sends a 3 volt DC to 11 volt DC signal to the BCM (burner controller module) when it is in contact with the pilot flame. The pilot flame **should be** about the size of a tennis ball and should heat the flame rod so it is red hot.

4) Burner Fan System

The burner fan provides additional combustion air for proper gas combustion. The fan provides approximately 900 cfm (cubic feet per minute) - 274 cmm - of air through the burner box. The airflow is obtained when the air pressure is measured at the air pressure tap on the gas burner box approximately 1.25-inches W.C. (water column) -3.1 millibar-. The combustion air system is comprised of the components described on [page 41](#) and [page 42](#).

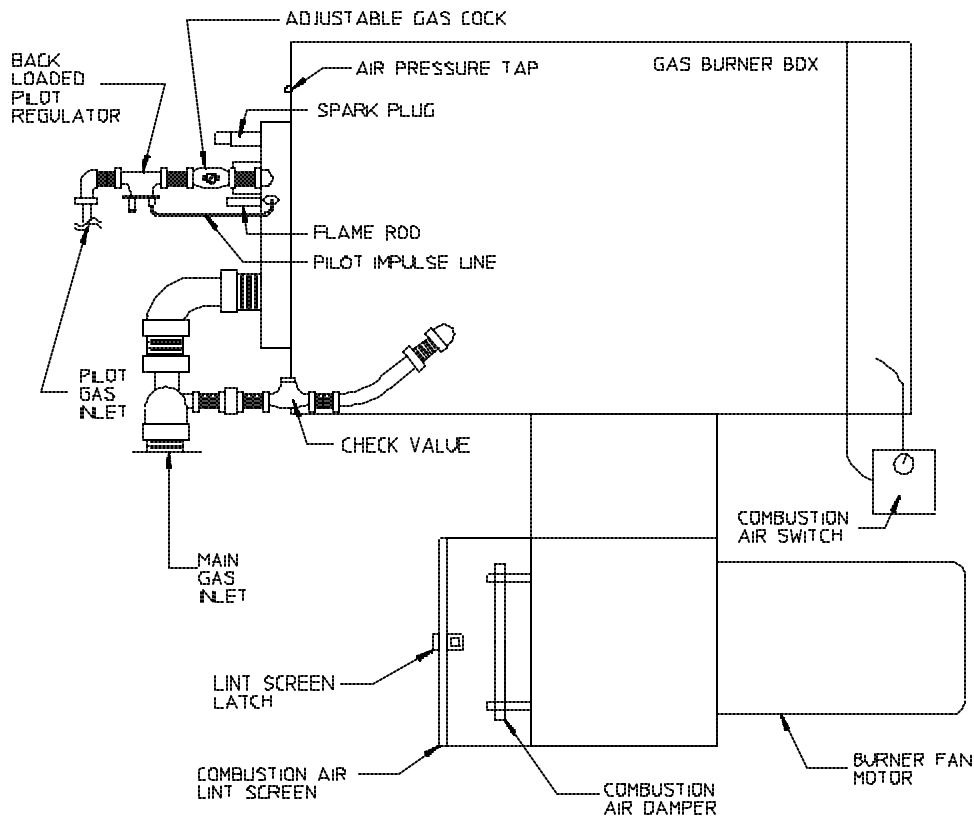

MANQ639

a) Burner Fan Air Switch

The differential in air pressure is measured by the burner fan air switch, which is located next to the burner fan motor. If the combustion air is inadequate, this switch will prevent ignition. The setting of this switch is adjustable, and it **should be** set at 12 to 15 millimeters (.4 - .6 inches water column [W.C.]) - .995 - 1.49 mbar.

b) Burner Fan and Motor

The combustion air is produced by a 6-1/4-inch (15.88 cm) squirrel cage fan which is attached to a 1-1/2 HP, 3,600 RPM motor. The motor **must spin** counterclockwise (CCW) as viewed from the rear of the motor.

c) Combustion Air Lint Filter

The combustion air lint filter is made of a fine mesh stainless steel screen which **must be** cleaned regularly. This screen prevents any lint from entering the burner box.

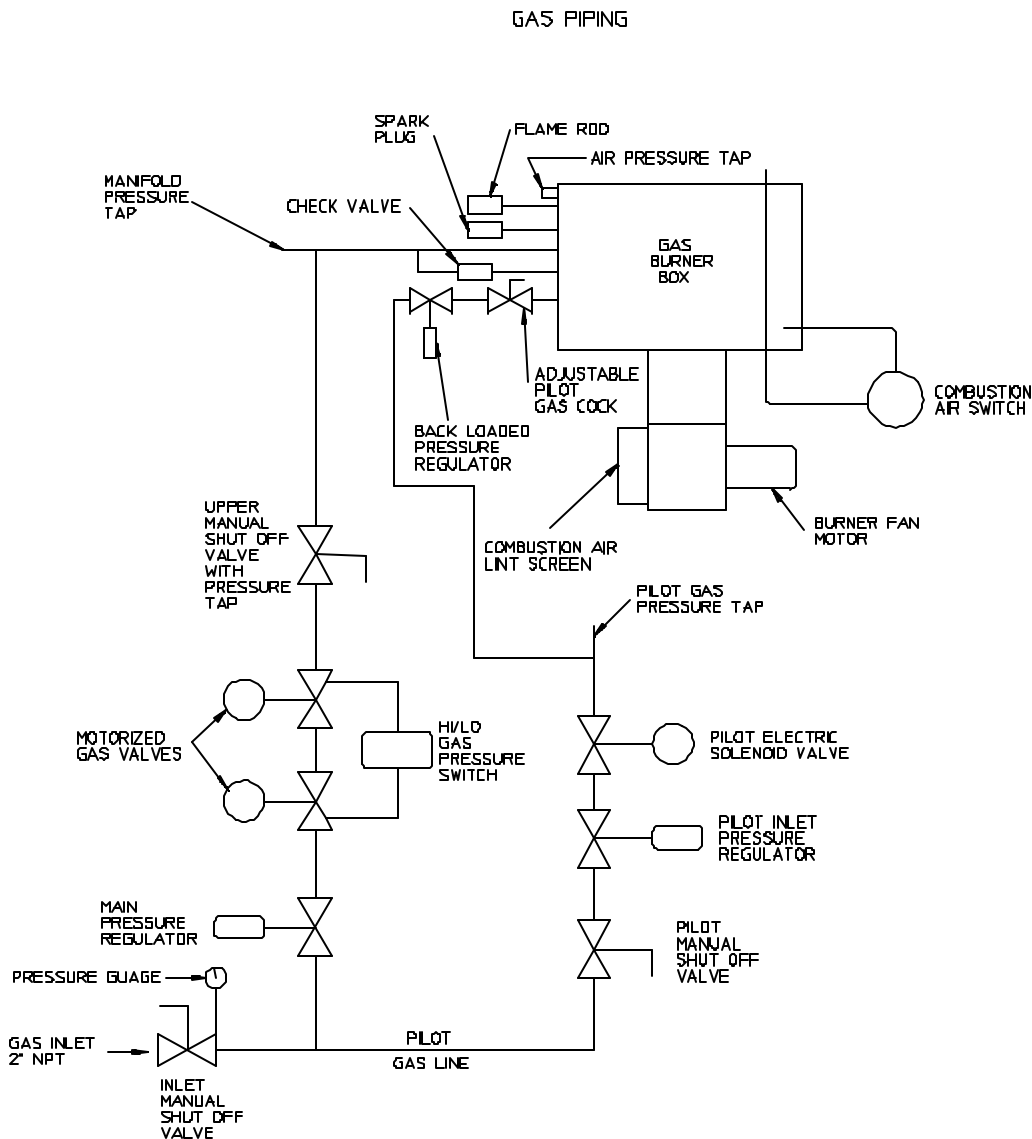

MAN4569

d) Combustion Air Damper

To produce the required combustion airflow, this damper can be adjusted. Remove the screen to get access to the damper. Moving the damper closer to the blower inlet opening will reduce the combustion airflow, and moving it away from the blower inlet opening will increase the airflow. To measure the combustion airflow, attached a manometer to the air pressure tap on the burner ~~box. The air pressure should measure~~ 1.25 to 1.50 inches water column (W.C.) (3.1 to 3.73 mbar)

5) Pilot Gas Supply Line

a) The pilot gas supply line consists of a manual shut-off valve, pressure regulator, electric solenoid valve, back-loaded pressure regulator, and an adjustable gas cock.

b) The gas pressure in this line **should be** approximately 3.5-inches water column (W.C.) - 8.70 mbar - for natural gas and 1.5-inches water column (W.C.) (3.73 mbar) for L.P. (liquid propane) gas. This will provide a bushy pilot flame, which produces a signal through the flame rod that is converted to a 3 DC to 11 volts DC in the burner controller module (BMC).

(1) This flame can be adjusted in two (2) ways.

(a) Pilot Inlet Pressure Regulator

Remove the cap and turn the slotted adjustment screw clockwise (CW) for more gas and counterclockwise (CCW) for less gas.

(b) Adjustable Pilot Gas Cock

Remove the cap and turn the slotted adjustment screw clockwise (WC) for less gas and counterclockwise (CCW) for more gas.

(2) The pilot line contains a back-loaded pressure regulator with an impulse line connected to the gas burner inlet. The regulator will maintain a constant pilot supply pressure in the burner due to an increase in temperature. **DO NOT adjust this regulator.**

6) Main Gas Supply Line

The main gas supply line consists of a pressure regulator, two (2) motorized shut-off valves, Hi/Lo gas pressure switch, and manual shut-off valve.

The gas pressure at the burner **should be** 2.5-inches water column (W.C.) - 6.22 mbar - for natural gas and 1.25 inches water column (W.C.) - 3.1 mbar - for L.P. (liquid propane) gas. This pressure is measured by a manometer at the pressure tap which is located above the top manual shut off valve.

a) Motorized Gas Valve

The two (2) 2-inch F.P.T. motorized valve are “ON/OFF” gas flow control valves. The valves motors operate on 120 VAC and are electrically “cascaded” so that upper valve will not open until lower valve has fully opened. A limit switch inside the lower motorized valve provides the signal that the valve is fully opened. These valves will open only when the burner controller module (BCM) is receiving a signal from the flame rod proving that the pilot flame is established.

Top Motorized Gas Valve

The valve sets the gas rate of 2,800,000 btu/hr (705,588 kcal/hr). To achieve this rate, the has pressure **must be** set for 2.5-inches water column (W.C.) - 6.22 mbar - for natural gas and 1.25 inch water column (W.C.) - .3.1 mbars - for L.P. (liquid propane) gas. To adjust, loosen the pan head screw located on the front of the top motorized valve, while holding the valve body, turn the flow adjustment clockwise (CW) for less gas and counterclockwise (CCW) for more gas. Retighten the pan head screw when correct gas flow is achieved. There is a switch located on the back of the top gas valve that verifies valve closure. The burner controller module (BCM) will go into a system unsafe error and the burner will not begin a burner sequence.

b) Sequence of Operation

With dryer power on, a 120 volt signal is sent to terminal #1 and terminal #2 of the BCM (burner controller module). A power indicator light has been added to the controller base for troubleshooting.

(1) Drying cycle is started

(2) Dryer computer calls for heat.

(3) The BCM (burner controller module) checks that **ALL** of the dryer's safety circuits are closed (terminal #7 of the BCM). If this is the case, then the "green" "operating interlocks" L.E.D. (light emitting diode) on the BCM will light. If a safety switch is open, the "green" L.E.D. **will not light**, and the "red" "SYSTEM UNSAFE" L.E.D. will light. The ignition sequence will stop.

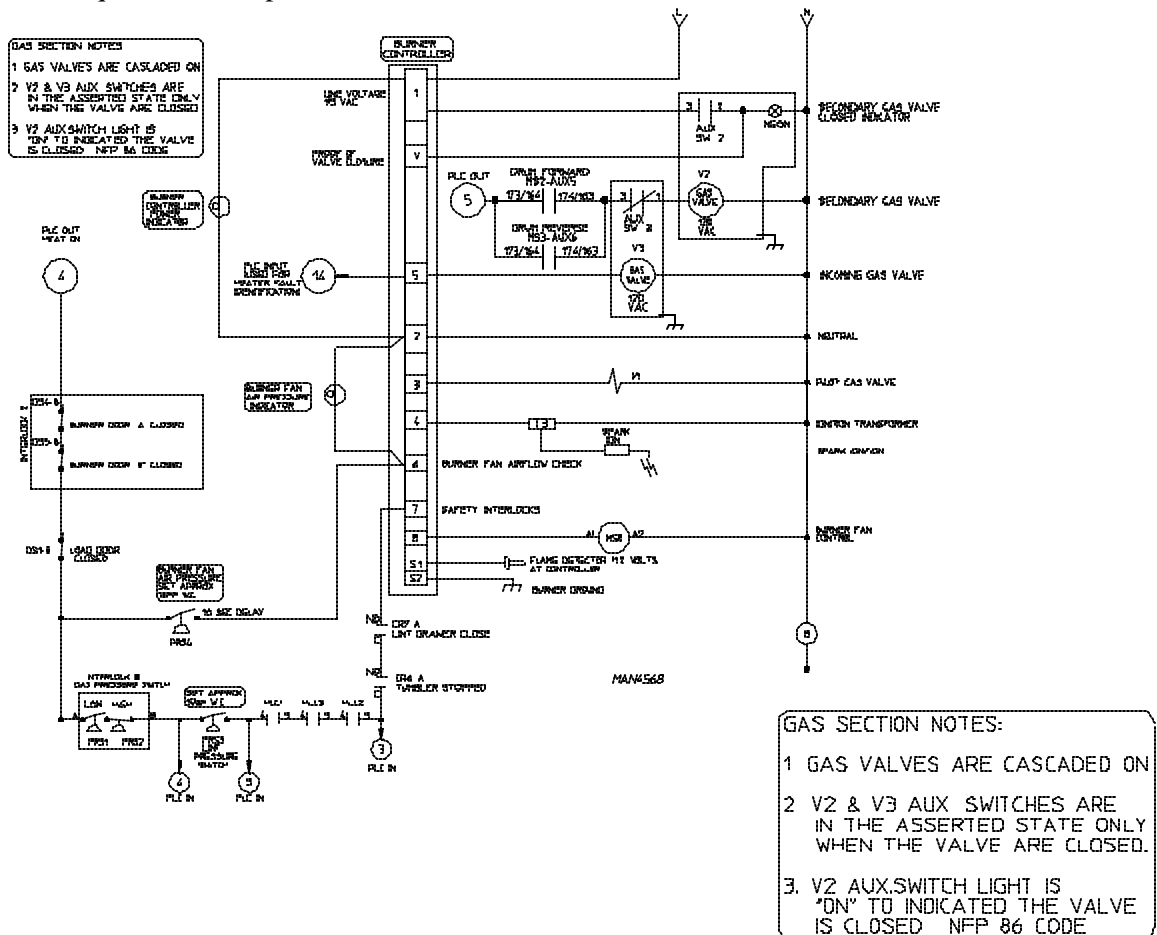

If **ALL** safety switches are closed, the burner controller module (BCM) will start the burner fan motor (BCM terminal #8).

The BCM (burner controller module) waits 10-seconds to allow the blower motor to get up to speed, and then checks that the burner fan combustion air switch (BCM terminal #6) circuit is closed. If this circuit is open during the drying cycle, the “Air Failure” L.E.D. (light emitting diode) will light. The gas valve will close, and a “HEATER FAULT” message will be displayed.

In order to prevent this air switch from being jumped out, the BCM (burner controller module) checks to insure that this circuit is open prior to start-up, then “SYSTEM UNSAFE” L.E.D. (light emitting diode) will light.

If the air flow switch closes after the burner fan is turned on, the pilot solenoid valve (BCM terminal #3) is opened for 10-seconds and a spark is produced (BCM terminal #4) by the burner spark plug, igniting the pilot flame.

The flame rod, which extends into the pilot flame, has 300 VAC on it from the (BCM terminal #S1). The flame lets the current flow from the flame rod to ground, which is then converted to 3 volts to 11 volts DC by the BCM (burner controller module). The “flame signal” L.E.D. (light emitting diode) on the BCM lights up.

The spark plug will turn off 1.5-seconds after the pilot flame is detected. If the pilot flame should fail during the 10-seconds period that the pilot solenoid is open. The BCM (burner controller module) will reenergize the spark. If the pilot flame is not established at the end of this 10-second period, the system will lock out and the “FLAME FAILURE” L.E.D. (light emitting diode) will light.

The 10-second period when the pilot solenoid opens and a spark is produced is called the trial-for-ignition (TFI) time. It is selected at either 5-seconds or 10-seconds by a dip switch located on the back cover of the BCM (burner controller module).

The 3 volt DC to 11 volt DC signal from the flame rod to the BCM (burner controller module) can be measured by;

- (a) Closing the manual shut-off valve in the main gas line to the burner. Leave the pilot manual valve open.
- (b) Push the Test and Reset Button on the cover of the burner control module (BCM) in to the “test” position.
- (c) Start a drying cycle... the burner controller module (BCM) will halt the ignition sequence after the pilot is ignited. The pilot flame **should be** about the size of a tennis ball and **should make** the flame sensor red hot.
- (d) Insert the positive probe of a DC voltmeter in to the “flame signal” port on the cover of the burner controller module (BCM). Connect the negative probe to ground.
- (e) If signal is less than 3 volts DC, then the pilot may be too small or too large, there may be a wiring connection between the flame rod and BCM (burner controller module), the flame rod may be dirty, (wash it with soap and water) or defective, or the grounding may be faulty.

Once the flame probe signal is detected by the burner controller module (BCM), it waits 5-seconds to allow the pilot to stabilize and then opens the main motorized gas valves (BCM terminal #5) in sequence.

The lower valve opens first. Upon full opening, its' internal switch closes, enabling the second motorized valve to open and full flame to be achieved.

If flame failure occurs within a 35-second period, the BCM (burner controller module) will recycle the ignition sequence once. If flame fails a second time, the system will lock out and the "FLAME FAILURE" pilot will light.

Once main flame is established, the burner will remain in the full fire mode until the drying set point temperature has been reached. At this point, the dryer computer will cycle the top motorized gas valve to the closed position. The "OFF" mode will be maintained until the dryer's temperature falls below the drying set point temperature. The motorized valve will then be returned to the full fire position. With voltage applied to the motorized valve, it moves to the full fire position. "OFF" is achieved when no voltage is applied to the motorized valve.

7) Gas Burner Start-Up

a) New gas lines are filled with air and **must be** purged before the burner will light. To do this close the upper manual shut-off valve, but leave the pilot line shut-off open. Push in the Test and Reset Button on the cover of the burner controller module (BCM). This will "freeze" the ignition sequence when the pilot flame ignites. This allows time to examine the pilot flame, and measure the flame rod signal to the BCM.

b) Connect a pressure gauge or water tube to the pilot gas pressure tap. Start the dryer;

Follow the ignition process by referring to the "Sequence of Operation" section of this manual.

c) When the pilot flame is ignited, the pilot gas pressure should measure 3.5-inches water column (W.C.) - 8.70 mbar - for natural gas and 1.5-inches water column (W.C.) - 3.73 mbar - for L.P. (liquid propane) gas. The pilot flame **should be** about as big as a tennis ball.

d) Once the pilot has been properly set, remove the pressure gauge from the pilot line connect a differential pressure gauge between the main gas pressure tap (HI port) and the air pressure tap (LO port) on the side of the gas burner box. The lines connecting the gauge to these taps **must be** long enough to allow the gauge to sit outside of the dryer so that the burner section access door can be closed when the dryer runs. Running the dryer with these doors open will give an incorrect air pressure reading.

e) Once this differential gauge is installed, open the main gas shut-off valve and push the Test and Reset Button on the burner controller module (BCM) so that the button springs out. Restart the dryer. The ignition process should now continue to the full gas flow state. The differential gauge **should read** 2.5 inches water column (W.C.) - 6.22 mbar - for natural gas and 1.25 inches water column (W.C.) - 3.1 mbar - for L.P. (liquid propane) gas. If it does not, adjust the top motorized valve as described in the **Top Motorized Gas Valve** on page 43.

E. SAFETY DEVICES

The ADG-464 dryer is equipped with numerous safety devices to ensure the dryer operates safely. The chart on the following page (**page 47**) lists each device with its location, function, computer display message, and result of tripping.

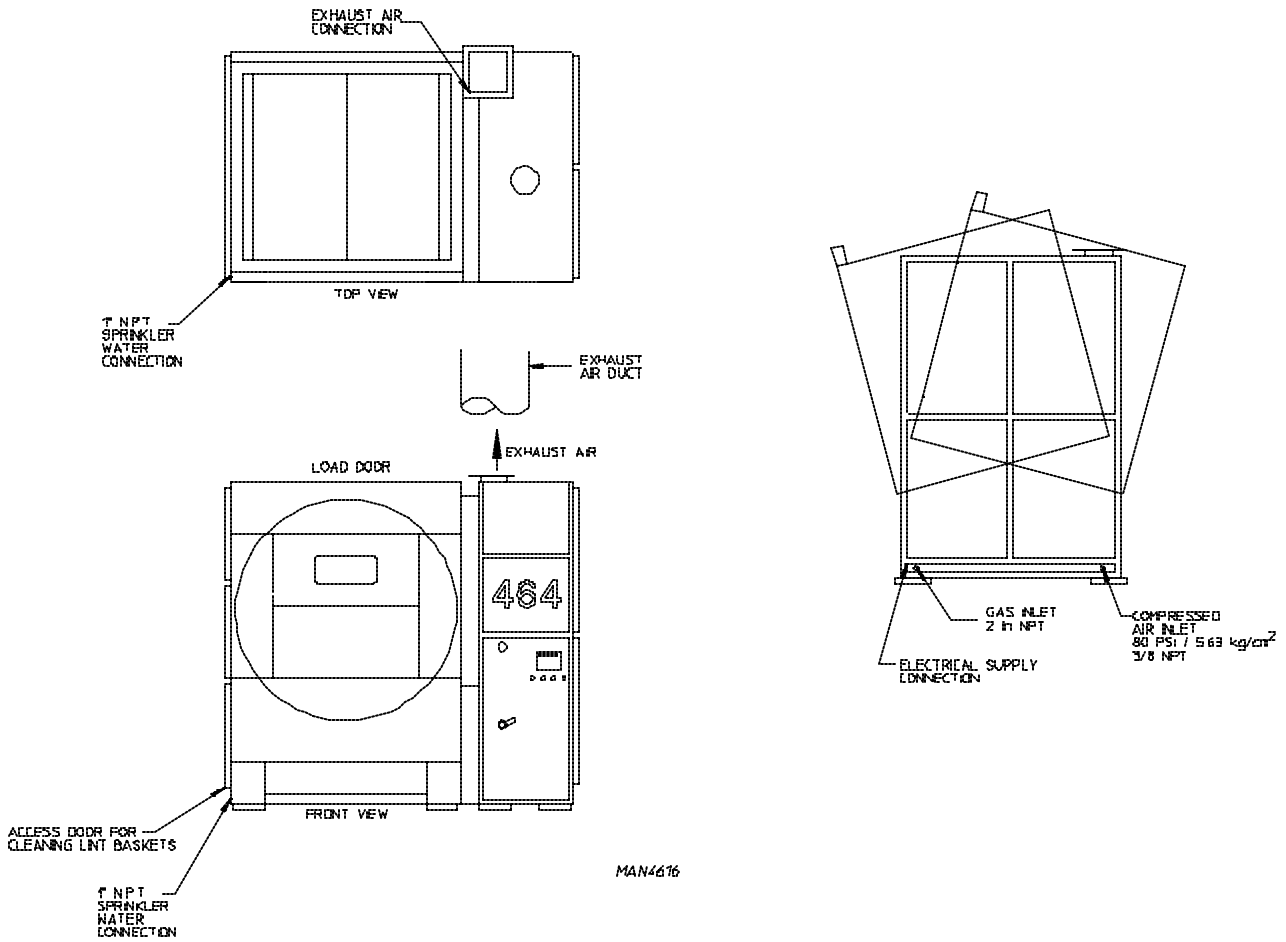

Safety Devices	Location	Function	Computer Display Message	Result of Tripping
Load Door Switch	Left side of Load door	Insures dryer load doors are closed	"DOOR OPEN"	Dryer will not run
Unload Door Switch (2-Door Dryers Only)	Right side of unload door	Insures dryer unload doors are closed	"DOOR OPEN"	Dryer will not run
Tilting Switches	Top left side of base module	Insures dryer is level	"LEVEL FAULT"	Dryer will not run
Drum Rotation Sensor	Left side of tumbler section	Insures tumbler is rotating	"DRUM FAULT"	Stops heat only
Lint Chamber Air Pressure Switch	Center of heat console	Insures proper air flow through dryer	"AIRFLOW FAULT"	Stops heat only
Burner Fan Air Flow Switch (Gas Dryers Only)	Center of heat console	Insures proper combustion air flow into the burner box	"HEATER FAULT"	Stops heat only
Hi/Lo Gas Pressure Switch (Gas Dryers Only)	Lower left of heat console section	Insures proper gas supply pressure for adequate ignition	"GAS SUPPLY FAULT"	Stops heat only
Heat Reclaimer Damper Switch	Right Side of heat console	Insures that the heat reclaimer is either opened or closed	Input LED #13 of the PLC is off	None
Heat Console Door Access Door Switch	Inside Heat Console	Insures that access doors are closed	"DOOR OPEN"	Dryer will not run
Exhaust Air Temp Control Sensor	Inside Burner section duct	Monitors tumbler exhaust air temp	"EXHAUST DSFL"	Stops heat only
Exhaust Air Hi Temp Control Sensor	Inside exhaust duct	Monitors tumbler exhaust and air temp	"HI-TEMP FAULT"	Stops heat only
Intake Air Temp Control Sensor (optional)	Top right of tumbler section	Monitors tumbler air intake temp	"INTAKE DSFL"	Stops heat only
Intake Air Temp Control Sensor	Top right of tumbler section	Monitors tumbler air intake temp	"HI-TEMP FAULT"	Stops heat only
Burner Hi-Limit Safety Sensor	Top of burner section	Monitors air temp above the burner box	"HI-TEMP FAULT"	Stops heat only
Sprinkler Control Safety Sensor	Top right of tumbler section	Open sprinkler system water valve on hi-temp condition	Orange sprinkler pilot light comes on. Alarm horn sounds	Opens the srpinkler water valve and power down the whole dryer
Lint Drawer Switches	Above lint drawer handles	Disables machine when drawers are open or if drawers have not been cleaned in last five loads	Lint Drawer	Dryer will not run

SECTION VII

SERVICE/PARTS INFORMATION

A. SERVICE

1. Service **must be** performed by a qualified trained technician, service agency, or gas supplier. If service is required, contact the reseller from whom the **ADC** equipment was purchased. If the reseller **cannot** be contacted or is unknown, contact the **ADC** Service Department for a reseller in your area.

NOTE: When contacting the **ADC** Service Department, be sure to give them the correct **model number** and **serial number** so that your inquiry is handled in an expeditious manner.

B. PARTS

1. Replacement parts **should be** purchased from the reseller from whom the **ADC** equipment was purchased. If the reseller **cannot** be contacted or is unknown, contact the **ADC** Parts Department for a reseller in your area. Parts may also be purchased directly from the factory by calling the **ADC** Parts Department at (508) 678-9000 or you may FAX in your order at (508) 678-9447.

NOTE: When ordering replacement parts from the **ADC** reseller or the **ADC** factory be sure to give them the correct **model number** and **serial number** so that your parts order can be processed in an expeditious manner.

SECTION VIII

WARRANTY INFORMATION

A. RETURNING WARRANTY CARDS

1. Before any dryer leaves the **ADC** factory test area, a warranty card is placed on the back side of the main door glass. These warranty cards are intended to serve the customer where we record the individual installation date and warranty information to better serve you should you file a warranty claim.
 - a. If a warranty card did not come with your dryer, contact the **ADC** Warranty Department or the **ADC** Service Department at (508) 678-9000.

IMPORTANT: A separate warranty card *must be* completed and returned for each individual dryer.

NOTE: Be sure to include the installation date when returning the warranty card(s).

B. WARRANTY

For a copy of the **ADC** commercial warranty covering your particular dryer(s), contact the **ADC** reseller from whom you purchased the equipment and request a dryer warranty form. If the reseller **cannot** be contacted or is unknown, warranty information can be obtained from the factory by contacting the **ADC** Warranty Department at (508) 678-9000.

NOTE: Whenever contacting the **ADC** factory for warranty information, be sure to have the dryer's **model number** and **serial number** available so that your inquiry can be handled in an expeditious manner.

C. RETURNING WARRANTY PARTS

ALL dryer or parts warranty claims or inquires **should be** addressed to the **ADC** Warranty Parts Department. To expedite processing, the following procedures **must be** followed:

1. No parts are to be returned to **ADC** without prior written authorization ("Return Material Authorization" [R.M.A.]) from the factory.

NOTE: An R.M.A. is valid for only thirty (30) days from date of issue.

- a. The R.M.A. issued by the factory, as well as any other correspondence pertaining to the returned part(s), **must be** included inside the package with the failed merchandise.

2. Each part **must be** tagged with the following information:
 - a. **Model number** and **serial number** of the dryer from which part was removed.
 - b. Nature of failure (be specific).
 - c. Date of dryer installation.
 - d. Date of part failure.
 - e. Specify whether the part(s) being returned is for a replacement, a credit, or a refund.

NOTE: If a part is marked for a credit or a refund, the invoice number covering the purchase of the replacement part **must be** provided.

NOTE: Warranty tags (ADC Part No. 450064) are available at “no charge” from ADC upon request.

3. The company returning the part(s) must clearly note the complete company name and address on the outside of the package.
4. **ALL** returns **must be** properly packaged to insure that they are not damaged in transit. *Damage claims are the responsibility of the shipper.*

IMPORTANT: No replacements, credits, or refunds **will be** issued for merchandise damaged in transit.

5. **ALL** returns **should be** shipped to the ADC factory in such a manner that they are insured and a proof of delivery can be obtained by the sender.
6. **Shipping charges are not the responsibility of ADC. ALL returns should be “prepaid” to the factory. Any “C.O.D.” or “COLLECT” returns will not be accepted.**

IMPORTANT: No replacements, credits, or refunds **will be** issued if the claim **cannot** be processed due to insufficient information. The party filing the claim **will be** notified in writing, either by “FAX” or “CERTIFIED MAIL - Return Receipt Requested,” as to the information necessary to process claim. If reply **is not** received by the ADC Warranty Department within thirty (30) days from the FAX/letter date, then no replacements, credits, or refunds **will be** issued, and the merchandise **will be** discarded.

SECTION IX

TROUBLESHOOTING

WARNING: YOU MUST DISCONNECT and LOCKOUT THE ELECTRICAL SUPPLY and THE GAS SUPPLY BEFORE ANY COVERS or GUARDS ARE REMOVED FROM THE MACHINE TO ALLOW ACCESS FOR CLEANING, ADJUSTING, INSTALLATION OR TESTING OF ANY EQUIPMENT per OSHA (Occupational Safety and Health Administration) STANDARDS.

The information provided will help isolate the most probable components associated with the difficulty described. The experienced technician realizes, however, that a loose connection, or broken or shorted wire may be at fault where electrical components are concerned. **DO NOT** necessarily suspect the component itself. Electrical parts **should always be** check for failure before being returned to the factory.

IMPORTANT: When replacing blown fuses, the replacement **must be** of the exact rating as the fuses being replaced. The information provided **should not** be misconstrued as a handbook for use by an untrained person in making repairs.

WARNING: ALL SERVICE AND TROUBLESHOOTING *SHOULD BE* PERFORMED BY A QUALIFIED PROFESSIONAL or SERVICE AGENCY.

WARNING: WHILE MAKING REPAIRS, OBSERVE ALL SAFETY PRECAUTIONS DISPLAYED ON THE DRYER or SPECIFIED IN THIS MANUAL.

The following information assumes that the reader has familiarized himself with the introduction to this manual, understands the ADG-464 dryer operation, and has knowledge of the programming features of the dryer.

<u>TROUBLESHOOTING TABLE OF CONTENTS</u>	<u>PAGE NUMBER</u>
A. POWER MALFUNCTIONS	52
B. BURNER IGNITION	61
C. TUMBLER (BASKET) ELECTRICAL MALFUNCTIONS	74
D. BASE SECTION ELECTRICAL MALFUNCTIONS	82
E. PENDENT CONTROL	87
F. TEMPERATURE SENSING	90
G. MOTORS	93
H. PLC (PROGRAMMABLE LOGIC CONTROLLER) MESSAGES	95

A. POWER MALFUNCTIONS

1. Main Disconnect Will Not Turn On

a. PROBABLE CAUSES;

- 1a) Sprinkler isolated power source “OFF” or disabled.
- 2a) OL12 tripped or sprinkler circuit defective.
- 3a) Sprinkler activated.
- 4a) Sprinkler will not reset.

b. POSSIBLE SOLUTIONS;

- 1b) Verify “**RED**” “Sprinkler Power” on main panel to be illuminated.

- If “ON” go to *paragraph #3b below*.
- If “NOT ON” verify isolated sprinkler power source to the dryer.

Check sprinkler supply voltage at TB1 pin #4 and pin #5.

- If “OK” go to *paragraph #2b below*.
- If none, check incoming line voltage.
- If none, check fuse disconnect switch.

- 2b) Check if OL12 has tripped.

- If “OK” go to *paragraph #3b below*.
- If tripped, check sprinkler circuit, then reset and test.

- 3b) Check if sprinkler is activated...is the “SPRINKLER RESET” button “lit”?

- If yes, press “SPRINKLER RESET.”

Does the sprinkler reset?

- If “yes,” attempt to turn “ON” the main disconnect again.
- If “no” go to *paragraph #4b below and on page 53*.

- 4b) Sprinkler will not reset, verify that the sprinkler hi-limit has not tripped. (“**GREEN**” light is off.)

- If it has not tripped, check setting to be 550° F (273° C) and verify that the sprinkler RTD (Resistive Temperature Device) is connected and has 100 ohms (100 Ω) at 32° F (0° C)/109 ohms (109 Ω) at 75° F (24° C).

- If RTD (Resistive Temperature Device) probe is defective, replace the probe.

NOTE: If ALL systems check out fine, call the **ADC** Service Department at (508) 678-9000.

2. No Control Power (“**BLUE**” Light Off)

a. PROBABLE CAUSES;

- 1a) Line voltage from main fused disconnected.
- 2a) Main disconnect on the ADG-464 is turned off.
- 3a) OL11 (overload #11) tripped.
- 4a) Fuse #1 is blown.

b. POSSIBLE SOLUTIONS;

- 1b) Verify main line voltage to ADG-464
 - If line voltage is present go to *paragraph #2b below*.
 - If line voltage is not present check fused disconnect and retest.
- 2b) Attempt to turn the ADG-464 main power handle to the “ON” position.
 - If the switch does not engage, verify that sprinkler power is “ON” (“**RED**” light on main door).
 - If “no,” refer to *paragraph #1b above*.
- 3) Open main enclosure and verify that OL11 has not tripped.
 - If yes, check circuit, restart and test.
 - If no go to *section #3 on page 54*.
 - Verify that fuse #1 has not blown, check that the “**RED**” L.E.D. indicator is off.
 - If “on” (fuse block L.E.D. “ON”), check circuit, replace fuse and test.

3. Machine Main Power Shuts Down (“**BLUE**” Indicator Off)

a. PROBABLE CAUSES;

- 1a) Sprinkler activated.
- 2a) OL12 (overload #12) tripped.
- 3a) “UNDER VOLTAGE FEATURE” of main disconnect has tripped.
- 4a) Sprinkler circuit defective.

b. POSSIBLE SOLUTIONS;

- 1b) Check if the sprinkler is activated, is “SPRINKLER RESET” button lit? Is the sprinkler alarm horn “ON”? Does the sprinkler water valve have its “ON” indicator extended?
 - If yes, it indicates that the sprinkler circuit has shutdown the Main Disconnect, press the lit “SPRINKLER RESET” button, does it reset?
 - If “no,” go to *paragraph 2b below*.
 - 2b) Verify that OL12 (overload #12) has not tripped.
 - If “yes,” check circuit, reset OL12, and test.
 - If “no,” go to *paragraph 3b below*.
 - 3b) The main disconnect has an “UNDER VOLTAGE DROP OUT FEATURE.” This feature requires that 110 VAC be present to engage the disconnect switch. If 110 VAC is removed from pin #51 and pin #52 on the switch, the disconnect will drop out automatically. Verify that 110 volts AC is supplied to the disconnect and that wires are secure.
 - If 110 VAC is present, the disconnect may be defective.
 - If 110 VAC is not present go to the *beginning of section 3 at the top of the page*.
4. Sprinkler circuit may be defective.

The following information will first describe the sprinkler circuit components and then provide a circuit description. Please refer to the ADG-464 ladder diagram (which is supplied with the machine) as the following is described.

SPRINKLER CIRCUIT COMPONENTS

- OL12 (overload #12) is a 1.6-amp magnetic and thermal overload device set 1-amp. Its function is to protect and the line voltage of the sprinkler circuit.
- T1 is a control transformer whose primary depends on the system line voltage (i.e., 208 VAC, 240 VAC, 380 VAC, 416 VAC, and 480 VAC). Refer to system’s nameplate. Its secondary is 110 volts AC.
- L3 is a “**red**” indicator installed on the electrical enclosure door. Its function is to indicate the presence of 110 VAC to the sprinkler system.
- Sprinkler High Limit Controller (SHLC) - Its function is to monitor a preset hi-limit temperature (which is currently set to 550° F [287.8° C]) and to control the activation of the “WATER SPRINKLER” circuit.
- SHLC’s (Sprinkler High Limit Controller’s) temperature information is derived from the RTD #4 (Resistive Temperature Device #4), a resistive sensor located on the top right hand side of the tumbler (basket) section. Its exact location is in proximity of the intake and hi-limit temperature probe.

IMPORTANT: An open RTD (Resistive Temperature Device) probe or disconnecting the probe under power will cause the sprinkler to active.

- **ALL** ADG-464 RTD (Resistive Temperature Device) probes are rated for 1,100° F (593.3° C).
- SHCL #2 (Sprinkler High Limit Controller #2) contacts (alarm and set point) are configured in the normally open state.
- #2CR (#2 control relay) and #3CR (#3 control relay) are relay coils that are energized in a logical manner for circuit control. The following are their associated relay contacts information.

RELAY	NORMALLY CLOSED CONTACTS	NORMALLY OPEN RELAYS
2CR	2CRB	2CR1
3CR	3CRB	NOT USED

- S11 and S12 are the actual electrical solenoid connections that turn on or shut off the air actuated water valve. The electrical connections for S11 and S12 are located in the solenoid junction box in the burner section of the ADG-464
 - S11 = Sprinkler ON
 - S12 = Sprinkler OFF

IMPORTANT: For proper sprinkler and dryer operation, sprinkler *must be* powered by a “separate or dedicated” single-phase (1Ø) multi-wire branch circuit at dryer’s nameplate voltage.

- L4 (light #4) is an “**amber**” light associated with PB #10 (push button #10), the “SPRINKLER RESET” button. These items are located on the electrical enclosure’s front panel. L4’s function is to give a visual indication that the sprinkler function is asserted and that the pneumatically activated water valve is open.
- The air actuated water valve also has a visual indicator to show its current state. Notice a “**RED**” button on the rear side of the valve.
 - IN = Valve CLOSED
 - OUT = Valve OPEN

NOTE: The sprinkler water inlet line has a hand operated gate valve and *must be* open for water to flow. It is suggested that this manual valve be closed when working on the dryer, to avoid problems caused by false tripping of the sprinkler circuit.

IMPORTANT: BE SURE TO TURN ON THE VALVE WHEN THE WORK IS COMPLETE.

- PB #10 (push button #10) “SPRINKLER RESET” button is for resetting the sprinkler circuit once the temperature in the tumbler (basket) has dropped below its preset trip temperature.

NOTE: Pressing the “SPRINKLER RESET” button before the tumbler (basket) temperature has dropped below its trip temperature will momentarily stop the water flow. However, the water flow will resume once the button is released.

- UV is the “UNDER VOLTAGE” detection coil of the ADG-464 MAIN DISCONNECT switch, DISC #1. It is this device that controls the automatic POWER DOWN of the dryer when the sprinkler is activated.

SPRINKLER CIRCUIT DESCRIPTION

The following information assumes that the reader has read the sprinkler component descriptions and is following the ADG-464 Ladder Diagram of the Sprinkler Circuit.

- STATE 1 - The tumbler (basket) temperature is “BELOW” SHLC (Sprinkler High Limit Controller) preset trip value. When power is applied to SHLC:
 - SHLC set point will close.
 - SHLC alarm will open.
 - UV (under voltage) will engage.

SUMMARY: With UV (under voltage control of the main disconnect) energized, the ADG-464 main switch may be turn on.

- STATE 2 - The tumbler (basket) temperature has risen “ABOVE” SHLC (Sprinkler High Limit Controller) preset trip value. With power is applied to SHLC:
 - SHLC set point will open
 - SHLC alarm will close
 - #2CR (#2 control relay) will become energized
 - S11 will be energized (sprinkler valve open)
 - L4 (light #4) will be energized (sprinkler valve open)
 - SP2 will activate alarm horn.
 - #2CR “B” will open.
 - SHLC alarm relay will toggle, causing the alarm contact to close and activate 2CR’s (control relay’s) coil. This action will;
 - Open 2CR “B” causing UV, the “under voltage” trip feature of the ADG-464’s main disconnect to shut down the “MAIN POWER” to the dryer.
 - Latch 2CR “A” “ON” to eliminate any automatic reset of the sprinkler solenoid.
 - Energize the “SPRINKLER ON” air solenoid.
 - Illuminate the “SPRINKLER RESET BUTTON.”
 - Sound sprinkler alarm horn.

NOTE: The sprinkler circuit will not reset until the ADG-464’s temperature is below the sprinkler hi-limit controller setting.

- STATE 3 - The tumbler (basket) temperature is still “ABOVE” SHLC (Sprinkler High Limit Controller) preset value and PB #10 (push button #10) “Sprinkler Reset” has been pushed and held “IN.” With power still applied to the SHLC:
 - #3CR will energize
 - S12 will energize
 - #3CR “A” will open
 - #2CR will de-energize
 - L4 will go off
 - SP2 will go off

SUMMARY: #3CR’s (#3 control relay’s) coil will energize causing:

- 3CR “A” will open and remove power from 2CR, S11, L4 and SP2.
- S12 “sprinkler off” air solenoid will activate turning off the actuated sprinkler valve.

IMPORTANT: If the tumbler (basket) temperature is still “ABOVE” SHLC (Sprinkler High Limit Controller) preset value, and the “SPRINKLER RESET” button is released the water valve will open again. (Refer to **STATE 2 above.**) If the tumbler (basket) temperature is “BELOW” the SHLC preset value when the “SPRINKLER RESET” button is released, the water valve will remain closed. (Refer to **STATE 1 on page 56.**)

4. Front Panel “BLUE” Light and “RED” Light “ON”

ADG-464 “ON” button does respond ...

a. PROBABLE CAUSES;

1a) **EMERGENCY STOP** BUTTONS 1, 2, and 3.

b. POSSIBLE SOLUTIONS;

1b) Verify that **ALL EMERGENCY STOP** buttons are pushed in.

- **EMERGENCY STOP 1** - main enclosed door
- **EMERGENCY STOP 2** - pendent control
- **EMERGENCY STOP 3** - rear control panel (2-door models only)
- If **ALL EMERGENCY STOP** buttons are “disengaged,” press “ON” located on the main enclosure door.
- If no, go to *section 3 on page 54*.

Does the system “GREEN” “ON” light illuminate?

- If not, check the **EMERGENCY STOP** and drying system “ON/OFF” circuits. (Refer to ladder diagram.)

5. Front Panel, “BLUE” (main panel) light, “RED” (sprinkler power) light, and “GREEN” (control power) light “ON”

The system has one or more of the following symptoms;

- OPERATOR INTERFACE TERMINAL - no display or displays “LINE FAULT” message.
- PROGRAMMABLE LOGIC CONTROLLER (PLC) - no indicator lights “ON.”
- CONVENIENCE OUTLET - no power.
- HI-LIMIT CONTROLLERS (HLS1 and HLS2) - no display.

a. PROBABLE CAUSES;

1a) Fuse 7 -- PLC (Programmable Logic Controller) power
Fuse 8 -- 24 volt DC power
Fuse 9 -- convenience outlet
Fuse 10 - hi-limit controller power

2a) Malfunctioning PLC (Programmable Logic Controller).

- 3a) Malfunctioning operator interface terminal or communications cable.
- 4a) Malfunctioning 24 volt DC power supply.
- 5a) Malfunctioning hi-limit temperature controller.

b. POSSIBLE SOLUTIONS;

- 1b) Verify that fuses 7, 8, 9, and 10 are good.

Check that **ALL** fuse holder L.E.D. (light emitting diode) indicators are not lit.

- If **ALL** fuses are good, go to *paragraph #2b below, paragraph #3b below, paragraph #4b below, or paragraph #5b below and on page 60.*
- If a fuse is bad, check the corresponding circuit, replace the fuse and test.

- 2b) Malfunctioning PLC (Programmable Logic Controller).

- If PLC power is off, a “LINE FAULT MESSAGE” will be displayed on the operator interface terminal.

NOTE: Call the ADC Service Department at (508) 678-9000.

- 3b) Malfunctioning operator interface terminal.

- Check power supply voltage to the operator interface terminal. It **should be** 24 volts DC.
- Check that the interface cable to both the PLC and the operator interface terminal are secure.

NOTE: Call the ADC Service Department at (508) 678-9000.

- 4b) Malfunctioning 24 volt DC power supply.

- Verify that the power supply’s red “ON” light is illuminated.
- Verify that 110 volt AC supply is available and correct.
- Verify that the 4-40 mA (4-40 milliamper) transmitters or operator interface terminal are not causing the power supply to fail.
- If the previous checked items are “OK,” replace the power supply.

- 5b) Malfunctioning hi-limit temperature controllers (HLS1 or HLS2).

- HLS1 - exhaust temperature hi-limit
- HLS2 - intake temperature hi-limit

HLS1 and HLS2 are monitored by a six (6) channel hi-limit temperature controller that once triggered **must be** manually reset.

General Description:

The six (6) channels accept independent RTD (Resistive Temperature Device) inputs (spare channels have a 100 ohm [100 Ω] 5% tolerance resistors installed) and there is an individual set point for each channel. In operation, the scan rate between channels is four (4) to six (6) seconds, and the display will have the temperature measured by the individual RTD's. A “**red**” L.E.D. indicates an alarm condition; in the event of an alarm, scanning is halted and the “ALARM” relay de-energizes until the manual reset button is depressed.

IMPORTANT: If a hi-limit alarm occurs, check that a hi-temperature has not occurred. If no, correct the condition and test.

IMPORTANT: ***DO NOT*** TROUBLESHOOT THE SHLC (Sprinkler High Limit Controller) UNLESS THE WATER VALVE TO THE SPRINKLER IS CLOSED.

SHLC will cause:

- The sprinkler water valve to open.
- The entire dryer to power down.
- The “SPRINKLER RESET” button on the main panel to light.

- With the dryer control voltage “ON,” not executing a drying cycle, one **should be** able to adjust the temperature settings on any of the hi-limit controllers and cause their respective “**GREEN**” L.E.D.’s (light emitting diodes) to cycle “ON” and “OFF.”
- If their corresponding L.E.D.’s (light emitting diodes) **do not** cycle, check their respective:
 - temperature sensors (RTD’s [Resistive Temperature Device])
 - power connections
 - electrical circuits (refer to the ADG-464 main electrical wiring diagram)
 - If the previous items are “OK,” replace the hi-limit controller.

B. BURNER IGNITION

Introduction

The heart of the ADG-464's burner control section is a burner controller module. It is located on the upper right hand side of the Main Electrical Enclosure panel and is described in detail in **Section VI, Part D, Gas Burner and Ignition System** on **page 37 thru page 45**).

As noted below the burner ignition section of the ADG-464 comprises a number of safety devices that have to be satisfied prior to burner ignition. Messages have been provided to aid one in isolating a specific area, however knowledge of the system is required to troubleshoot it.

The following information will provide means to respond to "Burner Fault Messages" and to verify ALL the signals necessary for BURNER IGNITION.

Burner Controller Input Signal Components

- AC POWER TO THE BURNER CONTROLLER
- PLC (Programmable Logic Controller) OUT 4 "HEAT ON"
- FUSE 15
- BURNER DOOR SWITCHES DSA4-A and DSA-B
- LOAD DOOR SWITCH DS1B
- UNLOAD DOOR SWITCH DS2-B
- BURNER FAN AIR PRESSURE SWITCH PRS2
- GAS HI PRESSURE and GAS LO PRESSURE SWITCHES PRS1 & PRS2
- LINT CHAMBER AIR PRESSURE SWITCH
- SIX (6) CHANNEL HIGH TEMPERATURE LIMIT SWITCH
- STOP MOTION DETECTOR RELAY CONTACT SMD NO
- FLAME DETECTOR PROBE
- BURNER CHASSIS GROUND

1. Burner Section Input Circuit Component Description

NOTE: Refer to ADG-464 Ladder Diagram for reference.

- AC POWER TO THE BURNER CONTROLLER

110 VAC power is supplied to the burner controller module PIN #1 through "FUSE 6." Power is applied to this point when "MCR" (motor control relay) is closed.

- PLC (Programmable Logic Controller) OUT "HEAT ON"

When this 110 VAC signal is asserted, a number of safety interlocks **must be** satisfied, before any burner ignition can take place. This signal is derived from the PLC OUTPUT #4 and is fused.

- FUSE 15

This fuse is located on the upper left hand section of the Main Electrical Enclosure Panel, with the other PLC output fuses. Its function is to protect PLC (Programmable Logic Controller) output.

- BURNER DOOR SWITCHES DS4B-DS5B (Interlock 2)

These switches are located on the burner doors, and are utilized to verify that they are closed. Their signals are terminated in the Solenoid Junction Box and then fed to the Main Electrical Enclosure.

- LOAD DOOR SWITCH DS1B

These switches are located on the left center of the load doors, and is used to verify that the doors are closed. The signal from this switch goes through a disconnect plug, to allow for services of the tumbler (basket), and terminates in the Tumbler Junction Box (TB4).

- UNLOAD DOOR SWITCH DS2-B

This switch is closed on the right center of the unload doors, and used to verify that the doors are closed. The signal from the switch goes through a disconnect plug, to allow for service of the tumbler (basket), and terminates in the Tumbler Junction Box (TB4).

- BURNER FAN AIR PRESSURE SWITCH PRS4

This adjustable switch is located centrally in the burner section of the AD-464. Its function is to monitor the Burner Fan Air Pressure, and signal the burner Controller Module Pin #6. This switch is terminated in the Solenoid Junction Box (TB2).

The following devices are used as a safety interlock to the Burner Controller. The devices have to be satisfied prior to burner ignition. The signal that flows through these devices terminate at Pin #7 on the Burner Controller.

- GAS HI PRESSURE and GAS LO PRESSURE SWITCH PRS1 & PRS2

These switches are housed in one enclosure, and are located in the left-center of the Burner Section. Their function is to monitor both HI and Lo gas pressure, and prevent ignition if the pressures do not fall in the correct range. The signals from these switches are terminated in Solenoid Junction Box, and transferred to the Main Electrical Enclosure.

- LINT CHAMBER AIR PRESSURE SWITCH PRS3

This switch, located at the rear left of the Base Section, is used to monitor the pressure of the Lint Screen Area. If this pressure is too low, caused by excessive lint or a defective switch the burner will not be allowed to ignite. The signal for this switch is terminated in the Base Junction Box, and transferred to the Main Electrical Enclosure.

- SIX (6) CHANNEL HIGH TEMPERATURE LIMITS SWITCH

This switch is located centrally on the Main Electrical Enclosure Panel and are used to shut down the burner in the event that a particular temperature has risen to level beyond the normal operating temperature of the dryer.

- STOP DETECTOR RELAY CONTACT SMD NO

This relay contact is used as an interlock to shut down the burner in the event that the tumbler (basket) has stopped for more than 12-seconds during a drying cycle. This contact resides in the Stop Motion Detector Module, located in the left side of the tumbler (basket) section just above the drive system.

- FLAME DETECTOR PROBE

This device is part of the AD-464 burner itself. Its function is to determine the presence of a flame and transfer this information through the Solenoid Junction Box and terminated on Pin #S1 of the burner controller.

- BURNER CHASSIS GROUND

This signal is derived for a wire attached directly to the Burner Chassis and through the Solenoid Junction Box and terminated on the S2 of the Burner Controller.

2. Output Signal Component Description

- PILOT GAS VALVE V1

This 110 VAC electrically activated valve is located on the lower left of the Burner Section. Its wires are terminated in the Solenoid Junction Box, and activated by a signal derived from Pin #3 of the Burner Controller.

- IGNITION TRANSFORMER T3

This transformer is located on the left side of the Burner Section. Its primary is terminated in the Solenoid Junction Box is connected to Pin #4 of the Burner Controller. Its secondary is connected to a spark igniter in the burner.

- MOTORIZED GAS VALVES V3 and V2

These 110 VAC motorized valves are located on the left side of the Burner Section, and are controlled by a signal from the Burner Controller Pin #5. Their connections are terminated in the Solenoid Box.

- BURNER FAN CONTROL

This 110 VAC output of PIN #8 of the Burner Controller is used to enable the Coil of MS8, a motor starter for the Burner Combustion Fan. MS4 AUX is used to insure that the lint fan and lint screen motors are powered prior to enabling MS8.

- “**RED**” INDICATOR LIGHT

Attached to the left side of the base of the burner controller is a “**RED**” indicator light. This indicator indicates the burner controller has power.

3. “GAS FAULT” Message (gas system only)

NOTE: Refer to ADG-464 Ladder Diagram for reference.

PLC (Programmable Logic Controller) MESSAGE - “GAS FAULT”

a. PROBABLE CAUSES;

- 1a) No gas.
- 2a) PLC (Programmable Logic Controller)out pin #4.
- 3a) Fuse #15.
- 4a) Interlock #2 (heater door switches).
- 5a) Load or unload door switches.
- 6a) Interlock #3 (PRS1 and PRS2) = HI/LO gas pressure switches.

b. POSSIBLE SOLUTIONS;

- 1b) Verify that a gas supply is connected to the dryer and that the gas valve is open. If gas supply is sufficient, verify the gas setting on PRS1 and PRS2 are correct.

PRS1 = LO pressure

PRS2 = HI pressure

Refer to the Installation Section for correct gas pressure settings and other gas supply information. If the Gas fault message continues to be displayed, perform the following electrical check out. Refer to the ADG-464 ladder diagram for the following directions:

- 2b) Verify that PLC (Programmable Logic Controller) OUTPUT L.E.D. #4 IS “ON.” This will indicate that the PLC is calling for “HEAT.”
 - If the L.E.D. is “ON,” this will indicate the signal is active. Go to **paragraph #3b below**.
 - If the L.E.D. is not “ON,” the PLC may be the problem.
- 3b) Verify that the fuse blown indicator of Fuse 15 is not lit wen PLC (Programmable Logic Controller) L.E.D. (light emitting diode) #4 is “ON.”
 - If “lit” check fuse; replace if necessary.
 - If not lit, verify that there is a 110 VAC signal on TB1-40, on the Main Electrical Panel.
 - If OK, go to **paragraph #4b on page 65**.
 - If not OK, check wire back to fuse.

Refer to the AD-464 Main Panel Wiring Diagram.

- 4b) To check “Interlock 2” (Heater Doors), verify that there is a 110 VAC signal on TB-41, on the Main Electrical Panel, when PLC (Programmable Logic Controller) output #4 is on.

NOTE: The heater door interlock switches are double-pole double-throw (DPDT). These switches affect different circuits.

- If there is 110 VAC at the panel go to *paragraph #5b below*.
- If there is not a signal, check circuit back to the burner door switches. Refer to the AD-464 Solenoid Junction Box Wiring Diagram for connection information.

- 5b) A quick way to check the load and unload door switches is to close the unload door (2-Door models) and toggle the load door’s “wobble arm,” and monitor INPUT #6 of the PLC (Programmable Logic Controller). Likewise, for 2-door models, close the load door and toggle the Unload door’s “wobble arm,” also monitor INPUT #7 of the PLC.

NOTE: The rotary arm switches mentioned are double-pole double-throw (DPDT), where the PLC (Programmable Logic Controller) signal and “door” switch effect different circuits.

- If input #6 L.E.D. (light emitting diode) of the (Programmable Logic Controller) goes on and off, the signal is “good.” Go to *Section #5* on **page 69 and page 70**.
- If input #6 L.E.D. of the PLC doesn’t react, then perform the following
- Power down the dryer.
- Close the Load and Unload doors.
- Check for continuity between TB1-70 and TB1-7 on the Main Electrical Panel

Refer to the AD-464 Main Panel Wiring Diagram.

- If no continuity, refer to the AD-464 Tumbler Junction Box Wiring diagram for detail information for door switch wiring.

- 6b) To check interlock 3 (PRS1 and PRS2), Gas pressure Hi/Lo switch:

- Power down the dryer.
- Check for continuity between TB1-18 and TB1-19.
- If no continuity, refer to the AD-464 Solenoid Junction Box wiring diagram for detail information for PRS1 and PRS2 wiring.

4. “HEATER FAULT” Message

PLC (Programmable Logic Controller) MESSAGE - “HEATER FAULT”

a) PROBABLE CAUSES;

- 1a) Fuse 6.

- 2a) Burner fan air pressure switch.
- 3a) Pilot gas valve.
- 4a) Ignition transformer.
- 5a) Motorized gas valves.
- 6a) MS4 AUX.
- 7a) MS8.
- 8a) Flame detector and burner chassis ground.
- 9a) Burner controller.

b) POSSIBLE SOLUTIONS;

1b) Verify that the burner controller module has power. With control voltage “ON,” verify that the burnt fuse L.E.D. indicator of fuse #6 is not “ON.”

- If the L.E.D. is “ON” check the fuse.
- If the fuse holder L.E.D. is “OFF” verify that MCR (motor control relay) pin #43 has 110 VAC, and that pin #1 of the burner controller is 110 VAC. The indicator light is on the left side of the burner base is the burner controller’s power indicator.
- If burner controller module has power, go to *paragraph #9b on page 69*.
- If burner controller module does not have power check circuit wiring and retest.

2b) Burner Fan Air Pressure Switch

This switch **must be** open prior to a drying cycle, and close during a drying cycle. This feature is required by the burner controller module. Check the function of this switch by measuring for 110 VAC from TB1-23 and TB1-9 on the main electrical panel.

Refer to AD-464 Main Panel Wiring Diagram.

- Press the “**green**” button on the front panel; control voltage “ON.”
- Measure for 110 VAC between TB1-23 and 9; it **should not** be present.
- If a voltage is measured check;
 - Air switch adjustment.
 - Switch.
 - Circuitry (AD-464 Main Wiring Diagram and AD-464 Solenoid Junction Box Wiring Diagram).

- If no voltage is measured;
 - Start a drying cycle, and monitor the voltages on TB1-23 and 9.
 - If a voltage is present during drying start-up, the switch is functioning.
- If a voltage is not present while the dryer is started, check:
 - Air Switch Adjustment.
 - Switch.
 - Circuitry (AD-464 Main Wiring Diagram and AD-464 Solenoid Junction Box Wiring Diagram).

3b) To check the electrical actuating of the pilot gas valve.

- Shut the main gas valve to the dryer.
- Open the disconnect block on TB1-63, for circuit testing. With control voltage “ON”, apply a 100 VAC line to TB1-63. THE PILOT GAS VALVE SOLENOID SHOULD ACTIVATE.
- If the solenoid does not cycle check circuitry; ADG-464 Main Wiring Diagram, and ADG-464 Solenoid Junction Box Wiring Diagram.
- Check gas valve solenoid.
- Retest.
- With the main gas valve OPEN, close disconnect block on TB1-63 and Measure for 110 VAC on TB1-63 and TB1-9 on the Main Electrical Panel during a drying cycle start-up.
- If a 110 VAC is present during start-up, burner pilot output circuit is OK.
- If a 110 VAC is not present;
 - Check circuitry; refer to ADG-464 Main Panel Wiring Diagram and ADG-464 Solenoid Junction Box Wiring Diagram).
 - Refer to **Section VI, Part D, Gas Burner and Ignition System** on **page 37 thru page 45**.

4b) To check the electrical actuation of the Ignition Transformer;

- Shut the main gas valve to the dryer.
- Open the disconnect block on TB1-65, for circuit testing with control voltage “ON”, apply a 110 VAC line to TB1-65 “output” ARCHING SHOULD OCCUR AT THE SPARK IGNITER IN THE BURNER ASSEMBLY.
- If there is arcing, close disconnect on TB1-65.

- If arcing does not occur:
 - Check circuitry; refer to ADG-464 Main Panel Wiring Diagram and AD-464 Solenoid Junction Box Wiring Diagram.
 - Check transformer
 - Check spark igniter in burner
 - Refer to the AD-464 Service Manual (ADC Part No. 450186) for more information on the burner controller module and burner start-up.
 - Retest

5b) To check the electrical actuation of the motorized gas valve:

- Shut the main gas valve to the dryer.
- Open the disconnect block on TB1-64, for circuit testing. With control voltage “ON” apply a 100 VAC a line to TB1-64 “output.” THE LOWER MOTORIZED GAS VALVE “V3” SHOULD OPEN. ONCE THE “V3” IS OPEN THE SECOND MOTORIZED GAS VALVE “V2” SHOULD OPEN.

NOTE: REMOVING THE VOLTAGE AT ANY TIME WILL CLOSE THE VALVES INSTANTLY.

- If valves operate properly, close disconnect on TB1-64.
- If the valves do not open correctly;
 - Check circuitry; refer to ADG-464 Main Panel Wiring Diagram and ADG-464 Solenoid Junction Box Wiring Diagram.
 - Check motorized valves
 - Refer to **Section VI, Part D, Gas Burner and Ignition System** on page 37 thru page 45.
 - Retest

6b) To verify that MS4 AUX is operational:

Start a drying cycle, MS4 contactor should pull in, and start the LINT FAN and LINT SCREEN motors. Simultaneously MS4 AUZ1 should close, enabling MS8 Coil (Burner Fan Motor) to be asserted by burner controller module. Does MS4 pull in?

- If MS4 pulls in go to ***paragraph #7b***
- If MS4 “DOES NOT” pull in;
 - Check that PLC (Programmable Logic Controller) OUTPUT 3 L.E.D. (light emitting diode) is “ON”
 - Check that fuse #14 L.E.D. (light emitting diode) “IS NOT” lit

- Check that “NONE” of the thermal and magnetic overloads have “TRIPPED.”
- Check circuitry; ADG-464 Main Panel Wiring Diagram
- Retest

7b) To verify burner fan motor contactor (MS8) operation:

Apply a 110 VAC voltage to MS8’s terminals A1 and A2 and verify that the contactor activates.

- If MS8 cycles this will indicate that its OK. Verify wiring to the device using the ADG-464 Main Panel Wiring Diagram.
- If MS8 “DOES NOT” cycle;
 - Check device and replace if necessary
 - Retest

8b) Flame Detector & Burner Chassis Ground

To test the flame detector signal refer to **Section VI, Part D, Gas Burner and Ignition System on page 37 thru page 45.**

- If the flame detector test fails:
- Verify that the flame detector and burner chassis connections, located on the left side if the burner, are sound and tight.
- Check wiring (See AD-464 Main Electrical Panel Wiring Diagram and AD-464 Solenoid Junction Box Wiring Diagram).
- Retest

9b) To test the burner controller module itself;

Refer to **Section VI, Part D, Gas Burner and Ignition System on page 37 thru page 45** for wiring information, concerning the Burner Controller Module (BCM), refer to the ADG-464 Main Panel Wiring Diagram, the ADG-464 Solenoid Junction Box Wiring Diagram, and the ADG-464 Ladder Diagram.

5. “AIR FAULT” Message

PLC (Programmable Logic Controller) MESSAGE “AIR FAULT”

a) PROBABLE CAUSES;

- 1a) Incorrect Fan (Blower) Rotation.
- 2a) Lint Chamber Air Pressure Switch.

b) POSSIBLE SOLUTIONS

1b) Visually check that the fan (Blower) rotate in the direction of its arrow.

- If rotation is incorrect:
 - Check rotation of the main fan blower ...

If the motor direction is wrong, swap phase 1 and phase 2 of the incoming power in the main electrical enclosure.

- Retest

2b) Check the lint chamber air pressure switch. Check the lint chamber pressure switch with control voltage “OFF”. Open disconnects on TB1-20 and TB1-21, and check resistance across the outputs of these two (2) connectors. (Refer to ADG-464 Main Panel Wiring Diagram). This will verify that the switch is open when the dryer is “OFF”. Check the lint chamber switch during a “DRYING CYCLE” close the disconnects on TB1-20 and TB1-21, and measure 110 VAC between TB1-9 and TB1-21 during a “DRYING CYCLE.”

- If 110 VAC is measured the switch is functioning OK.
- If 110 VAC “IS NOT” present;
 - Check switch’s pressure adjustment (refer to AD-464 Ladder Diagram for reference)
 - Check that switch cover is in place and screws are snug.
 - Check that lint screen is clean.
 - Check that wiring; refer to following wiring diagrams:
 - AD-464 Base Junction Box Wiring Diagram
 - AD-464 Main Panel Wiring Diagram

6. “HI-TEMP FAULT” Message

PLC (Programmable Logic Controller) MESSAGE “HI-TEMP FAULT”

a) PROBABLE CAUSES;

- 1a) Air Flow
- 2a) Hi-Limit Temperature Controllers (channel 1, 2, 3 gas systems)
- 3a) RTD (Resistive Temperature Device) 1, 2 or 3 gas systems.
- 4a) Fuse #10

b) POSSIBLE SOLUTIONS;

- 1b) For Air Flow problems refer to **SECTION III - Item D (External Supply Connections) - paragraph #4 (Exhaust Air Ducting)** on **page 20 and page 21**.

NOTE: An illuminated “RED” L.E.D. (light emitting diode) indicator on the HI-TEMP CONTROLLER indicates that the Hi-Limit control relays is in “ALARM” and an internal relays is “OPEN”.

- If anyone of the HI-LIMIT Temperature SENSORS sense an over temperature condition. It will open its control relay. (Refer to the AD-464 Ladder Diagram for the effect of this relay).
- If a “HI-TEMP FAULT” message is displayed, open the main electrical enclosure, and notice which channel has cycled. This will lead one in the direction of the fault.

HLS1 = MAXIMUM INTAKE TEMPERATURE

HLS2 = MAXIMUM OVER BURNER TEMPERATURE

HLS3 = MAXIMUM EXHAUST TEMPERATURE

- The HI-TEMP controller channel that has a ‘GREEN’ L.E.D. (light emitting diode) “ON,” indicates the RTD (Resistive Temperature Device) that caused the message (HI-TEMP FAULT) to be displayed.
 - Let the dryer cool and verify that “GREEN” L.E.D.’s resume scanning. Reset the controller by pressing the “REST” on the controller. This will verify that an over temperature condition occurred and the controller is operational.
 - Go to **paragraph #1b** above and check air flow.
 - If the HI-LIMIT controller does not reset go to **paragraph #3b** on **page 72**.
- 2b) If either RTD (Resistive Temperature Device) 1, 2, 3 were to open or become disconnected, the associated temperature channel, of the hi-temp controller located on the Main Electrical Panel, will sense the open and react by opening its respective control relay and never reenergize until the RTD was replaced. Once a HI-LIMIT controller problem has been isolated to a particular device, and a RTD temperature sensor is suspected:

Check the resistance of the RTD (Resistive Temperature Device) at its connector, located in the right hand cable through.

- If 0 ohms (0 Ω) is measured;
 - Check RTD (Resistive Temperature Device)
 - Check wiring to the RTD (refer to the main panel wiring diagram)
 - Check wiring to the HI-LIMIT temperature controller (refer to the AD-464 Main Panel Wiring Diagram).

- If 0 ohms (0 Ω) is measured;
 - Check RTD (Resistive Temperature Device)
 - Check wiring to the RTD (refer to the main panel wiring diagram)
 - Check wiring to the HI-LIMIT temperature controller (refer to the AD-464 Main Panel Wiring Diagram).
- If RTD (Resistive Temperature Device) measures in the range of 100 ohms (100 Ω);
 - Check wiring to the HI-LIMIT Temperature Controller (refer to the AD-464 Main Panel Wiring Diagram).
- If wiring checks out;
 - Replace the HI-LIMIT Temperature Controller
 - Retest

3b) If there is no display on the HI-LIMIT Temperature Controller:

- Check that main power is “ON;” front panel “BLUE” indicator.
- Check that **ALL** “EMERGENCY STOP” (E-Stop) buttons are disengaged (out).
- Check fuse 10’s blown fuse indicator.
- Check wiring; (refer to the AD-464 Main Panel Wiring Diagram).
- Retest

7. “DRUM FAULT” Message

PLC (Programmable Logic Controller) MESSAGE “DRUM FAULT”

a) PROBABLE CAUSES;

1a) Stop motion detector module or sensor. With control voltage “ON” (“GREEN” push-button), use the pendant control in “LOAD POSITION” to rotate the tumbler (basket).

NOTE: Input #0,10 on the RTD (Resistive Temperature Device), stop the tumbler (basket) and wait for device’s latched relay to de-energize. The time from when the tumbler (basket) stopped to the relay de-energizing *should be* 15 to 20 seconds.

- If the de-energizing time is satisfactory, the unit is operating correctly;
- Check circuit wiring, and retest (refer to the AD-464 Main Panel Wiring Diagram).

- If the de-energizing time is incorrect:

- Adjust the “time adjust” on the stop motion detector module and retest.

If the input #0, 10 on the PLC (Programmable Logic Controller) is not on after several rotations of the tumbler (basket):

- Check fuse #2 and replace if necessary.
- Rotate the tumbler (basket) using the pendant control in ”LOAD POSITION.” Does the module’s L.E.D. (light emitting diode) respond?
- If yes, adjust the “sense time” until the L.E.D. (light emitting diode) stays on for 12 to 15 seconds after the tumbler (basket) stops, then refer to *Section 7a* on **page 72**.
- If no, check:
 - Inductive proximity sensor for damage.
 - Sensor distance from targets is 3/16” (4.7 mm). The proximity sensor is located in the same area as the tumbler junction box.
 - Inductive proximity adjustment.
 - Tumbler (basket) target.
 - Stop motion detector module.
 - Circuit wiring;

Refer to the AD-464 Main Panel Wiring Diagram, AD-464 Tumbler Junction Box Wiring Diagram.

C. TUMBLER (Basket) SECTION ELECTRICAL MALFUNCTIONS

Introduction

There are a number of electrical components associated with the AD-464 tumbler (basket) section. These components are **ALL** interfaced to the tumbler junction box, and connected to the main electrical enclosure through a dis-connectable cable.

The “tumbler junction box” is located on the left side of the tumbler (basket) section, in the same area as the left drum motor. The title of the wiring diagram for the tumbler (basket) section is “AD-464 Tumbler Electrical Junction Box Wiring Diagram.”

The tumbler (basket) section electrical components provide:

- FRONT and REAR DOOR INFORMATION
- DRUM ROTATION INFORMATION
- REAR PANEL CONTROLS FOR UNLOADING
- EMERGENCY STOP (E-Stop)

The following information will provide a means to respond to fault messages associated with the tumbler (basket) section, and verify **ALL** the electrical signals associated with it.

1. Tumbler (Basket) Section Electrical Components

a) Load Door Switch - DS1

The load door switch is located on the left side of the AD-464 front doors and is comprised of four (4) parts; head, arm, body, and cord grip device. The head is a rotating type, with a spring arm attached for switch actuation. The body contains a double-pole-double-throw (DPDT), normally open switch. DS1 - has two (2) electrical functions, “A” and “B.”

b) Unload Door Switch - DS2

The unload door switch is located on the right side of the AD-464 rear doors and is comprised of four (4) parts; head, arm, body, and cord grip device. The head is a rotating type, with a spring arm attached for switch actuation. The body contains a double-pole-double-throw (DPDT), normally open switch. DS1 - has two (2) electrical functions, “A” and “B.”

“A” provides rear door position signal to the PLC (Programmable Logic Controller).

“B” is a rear interlock to the burner controller circuit.

c) Drum Rotation Sensor – PRS1

The drum rotation sensor is an inductive pick up device located on the left wrapper of the tumbler (basket) section. Its function is to sense a metal “target” attached to the “basket” as it rotates. The mechanical adjustment of this device, (distance from the target) is crucial (3/16” [4.7 mm] maximum from target).

CAUTION: *DO NOT* MECHANICALLY ADJUST THE ROTATIONAL SENSOR SO FAR IN TO BE HIT BY THE ROTATING TARGET, PERMANENT DAMAGE OF THE SENSOR WILL OCCUR.

d) Tumbler Junction Box

This enclosure interfaces the tumbler's electrical hardware, to the AD-464 Main Electrical Panel. The disconnect plug, attached to this enclosure, provides a means of electrical separation of these tumbler (basket) section, for shipping.

Refer to AD-464 Tumbler Junction Box Diagram for detailed wiring information.

The following is for 2-Door Models ONLY

e) Unload 1 "Rear Panel" – SEL 4

This is normally open, two (2) position, selector switch for unloading the AD-464 from the rear. Once the selector switch is turned to "1," Pendant control functions are disabled, rear doors open, and the dryer front tilts up.

f) DRUM FORWARD "Rear Panel" – PB3

This push button switch comprises of two individual switches; one normally closed and one normally open. One switch is for a drum forward signal to the PLC (Programmable Logic Controller); the other switch is for an electrical interlock to the DRUM REVERSE push button.

g) DRUM REVERSE "Rear Panel" – PB4

This push button switch comprises of two (2) individual switches; one normally closed and one normally open. One switch is for a drum reverse signal to the PLC (Programmable Logic Controller); the other switch is for an electrical interlock to the DRUM FORWARD push button.

h) EMERGENCY STOP (E-Stop) "Rear Panel" – PB7

This push button switch is normally closed device and is located on the right rear panel of the AD-464. Its function is to shut down the control voltage to the dryer in the event it is pressed.

NOTE: The EMERGENCY STOP (E-Stop) WILL NOT disengage the sprinkler circuit power.

2. Rear Panel Control Problems

EMERGENCY STOP (E-Stop) Function

a) PROBABLE CAUSES;

- 1a) Rear panel disconnect plug
- 2a) Defective switch
- 3a) Wiring back to the main electrical enclosure

b) POSSIBLE SOLUTIONS;

1a) If the EMERGENCY STOP (E-Stop) - rear - does not respond:

- Verify that **ALL** other EMERGENCY STOP (E-Stop) buttons are pulled out.
- Verify that the rear panel's disconnect plug is indeed connected. The disconnect plug is to allow the removal of the rear panel for drying servicing.

2b) Defective EMERGENCY STOP (E-Stop) Switch

- Shut power off (main breaker) remove the rear panel and check switch using an OHM meter; replace if defective.
- Retest

3b) Wiring Back to Main Electrical Enclosure

- Shut power to the AD-464 dryer (Main Breaker).
- Open “disconnects” on terminal #16 and terminal #17 of TB1; These disconnects are located on the bottom of the main electrical enclosure.
- Connect an OHM meter to the output side of terminal #16 and terminal #17 of TB1.
- Push in the EMERGENCY STOP (E-Stop) button (opening the switch)
- Does the previous test show that there's a switch closure opening?
 - If yes, refer to *paragraph 3b* above.
 - If no, refer to *paragraph 4b* below.

4b) Wiring from the EMERGENCY STOP (E-Stop) button to the main electrical enclosure is OK.

- Check REAR PANEL CONTROLS WIRING DIAGRAM
- Check TUMBLER JUNCTION BOX WIRING DIAGRAM
- See *paragraph 3a* above and retest

3. Rear Panel Control Problems

a) PROBABLE CAUSES;

1a) Rear Panel Disconnect Plug.

2a) Defective Switches.

3a) Wiring back to the main electrical enclosure.

b) POSSIBLE SOLUTIONS;

1b) If either the Drum forward or reverse functions (rear) don't respond:

- Verify that the rear panel controls disconnect plug is indeed connected. This disconnect plug allows for the removal of the rear control panel for dryer servicing.

2b) Defective Forward and Reverse Switch

- Shut power off at the main breaker and remove the rear panel and check switches using an OHM meter; replace if defective.
- Retest

3b) Wiring Back to Main Electrical Enclosure

- With the control voltage "ON" front panel "GREEN" button
- Select "1" on the "O UNLOAD 1" switch located on the rear controls panel.
- Have someone PRESS either the forward or reverse buttons while you watch the input L.E.D.s (light emitting diode) of the programmable controller. Do the associated L.E.D.s light?

PLC PIN 20 = DRUM FWD., REAR PANEL

PLC PIN 21 = DRUM REV., REAR PANEL

- If yes, refer to *paragraph 2 (section a)* on **page 75**.
- If no, refer to *paragraph 2 (section b)* on **page 76**.

4b) The L.E.D.s (light emitting diodes) illuminating on the PLC (Programmable Logic Controller) indicate that the wiring to the PLC is correct.

- Check FUSE #2 on the Main Electrical Panel
- Check wiring back to the Tumbler Junction Box
- Check wiring back to the rear controls

Refer to wiring diagrams:

- Main Electrical Panel Diagram
- Tumbler Junction Box Wiring Diagram
- Rear Panel Controls Wiring Diagram
- Retest

4. O UNLOAD 1 Selection

a) PROBABLE CAUSES;

- 1a) Rear Panel Disconnect Plug.
- 2a) Defective Switch.
- 3a) Wiring Back to Main Electrical Enclosure.

b) POSSIBLE SOLUTIONS;

1b) If the O UNLOAD 1 Switch does not respond when selected:

- Verify that the rear panel controls disconnect plug is indeed connected. This disconnect plug allows for the removal of the rear control panel for drying servicing.

2b) Defective O UNLOAD 1 Selector Switch

- Shut power off at the main breaker and remove the rear panel and check switches using an OHM meter; replace if defective.

3b) Wiring Back to the Main Electrical Enclosure

- With the control voltage “ON” Front Panel Green Button
- Select “1” on the “O UNLOAD” switch located on the rear control panel. Does the PLC (Programmable Logic Controller) IN PIN 19 = UNLOAD, REAR PANEL light?
 - If yes, refer to **paragraph 3a** on **page 76**.
 - If no, refer to **paragraph 4b** on **page 76**.

4b) The L.E.D. (light emitting diode) “ON” on the PLC (Programmable Logic Controller) indicates are also illuminating when the O UNLOAD 1 selector switch is on “1”.

PLC OUT PIN 7 = UNLOAD DOOR (OPEN)

PLC OUT PIN 10 = FRONT UP

- If output indicators are functional, however the UNLOAD DOORS or FRONT UP commands are not executed correctly:
- Check wiring on the MAIN ENCLOSURE PANEL (refer to the AD-464 MAIN PANEL WIRING DIAGRAM)
- Check wiring associated with the Solenoid Junction Box
- Refer to troubleshooting procedures associated with the Solenoid Junction Box

5b) Input 19 L.E.D. (light emitting diode) is not illuminating correctly on the PLC (Programmable Logic Controller) indicates that the signal to the PLC input is missing or the PLC is defective.

- Check FUSE 2 on the main electrical panel
- Check wiring back to the tumbler junction box
- Check wiring back to the rear controls
- Check PLC (Programmable Logic Controller)

Refer to wiring diagrams:

- Main Electrical Panel Diagram
 - Tumbler Junction Box Wiring Diagram
 - Rear Panel Controls Wiring Diagram
- Retest; verify that the signal is operational

5. "DOOR OPEN" Problem

A "DOOR OPEN" message is generated by either the heater, load , or unload doors. The following information will address the load and unload doors signals, since they are associated with the tumbler junction box.

a) PROBABLE CAUSES;

1a) Wiring back to the PLC (Programmable Logic Controller).

DS1-B = LOAD DOOR SWITCH

DS2-B = UNLOAD DOOR SWITCH

b) POSSIBLE SOLUTIONS;

1b) For quick check of LOAD and UNLOAD signals on the PLC (Programmable Logic Controller) perform the following:

- Remove factory air from the dryer
- With the Control Voltage "ON," open the LOAD doors and locate the LOAD door switch actuator.
- Cycle the switch by hand and have someone watch PLC input indicator #6. It should go "ON" when the switch is down.
- Open the UNLOAD doors and locate the UNLOAD doors switch actuator.
- Cycle the switch by hand and have someone watch PLC input indicator #7. It should go "ON" when the switch is down. Do the associated L.E.D.'s (light emitting diodes) come "ON" when the switch is down?

- If yes, wiring is OK:
 - Check switch placement and door actuation.
- If no, check associated:
 - Switch and wiring
 - Check wiring back to the tumbler junction box
 - Check wiring back to the Rear Controls
 - Check PLC (Programmable Logic Controller)

Refer to wiring diagrams:

- Tumbler Junction Box Wiring Diagram
 - Rear Panel Controls Wiring Diagram
- Retest; verify that the signal is operational

6. "DRUM FAULT MESSAGE" Malfunction

a) PROBABLE CAUSES;

- 1a) Stop Motion Detector Module or Sensor.
- 2a) Wiring back to Main Electrical Enclosure

b) POSSIBLE SOLUTIONS;

Open the Main Electrical Enclosure locate input #0, 10 on the PLC (Programmable Logic Controller). With control voltage "ON" ("GREEN" Push-Button), use the pendant to rotate the tumbler. Notice a L.E.D. (light emitting diode) on as the tumbler (basket) is rotating.

If the L.E.D. is off, refer to *paragraph 6 (section a)* above.

1b) If the L.E.D. (light emitting diode) is off:

- Check Fuse #2; replace if necessary.
- Rotate the tumbler using the pendant control, and adjust the stop.
- Does the module's L.E.D. (light emitting diode) respond?
- If yes, adjust the "Time Adjust" until the LED is on during rotation 12 to 15 seconds after.
- If no, check:
 - Inductive Proximity Sensor for Damage

- The Proximity Sensor is located in the same area as the Tumbler Junction Box
- Inductive Proximity Mechanical Adjustment
- The target that is attached to the outside of the tumbler (basket).
- Stop motion detector module.
- Circuit wiring; refer to the AD-464 Main Panel Wiring Diagram, AD-464 Tumbler Junction Box Wiring Diagram

2b) If the L.E.D. (light emitting diode) is constantly “ON”

- If yes, the stop motion detector is defective.
- If no, check:
 - Inductive Proximity Sensor for damage. The proximity sensor is located in the same area as the Tumbler Junction Box.
 - Inductive Proximity Mechanical Adjustment.
 - Tumbler (basket) target. This target is attached to the outside of the tumbler (basket).
 - Stop motion detector module in the tumbler (basket) section on the left front side.
 - Circuit Wiring; refer to the AD-464 Main Panel Wiring Diagram.
 - AD-464 Tumbler Junction Box Wiring Diagram.

D. BASE SECTION ELECTRICAL MALFUNCTIONS

Introduction

There are four (4) electrical components associated with the AD-464 base section. These components are interfaced to a junction box, and connect to the main electrical enclosure through a disconnect cable. The “Base Junction Box” is located on the right rear of the base section, and title of its wiring diagram is “AD-464 Base Electrical Junction Box Wiring Diagram.” The base section electrical components provide:

- Tumbler position information (Front Up - Level Rear Up)
- Lint chamber pressure information
- Lint screen mechanism functioning OK information

The following information will provide a means to respond to “Base” associated fault messages, and to verify all the electrical signals associated with the base section. Refer to the AD-464 Base Junction Box for detailed wiring diagram.

1. Front Door Switch

The “front down sensing switch” is located on the left side of the AD-464 base and comprises of four (4) parts: head, arm, body, and cord grip device. The head is a rotating type, with a roller arm attached for switch actuation. The body contains a double-pole-double-throw (DPDT), normally opens switch. LS1 - has two (2) electrical functions, A and B.

“A” provides a “front down” signal to the PLC (Programmable Logic Controller)

“B” is used as an electrical interlock to the “Rear Up Signal”

2. Rear Down Switch - LS2

The “rear down sensing switch” is located on the left side of the AD-464 base, and comprises of four (4) parts: head, arm, body, and cord grip device. The head is rotating type, with a roller arm attached for switch actuation. The body contains a double-pole-double-throw (DPDT), normally open switch. LS2 - has two (2) electrical functions, A and B.

“A” provides a “rear down” signal to the PLC (Programmable Logic Controller)

“B” is used as an electrical interlock to the “Front Up Signal”

3. Lint Drawer Proximity Switches

The “Lint Drawer Proximity Switches” are located on the left side of the AD-464 base, and comprises of six (6) parts: Junction Box, two (2) proximity switches, and three (3) cord grip switches. The switches sense a magnet installed on the lint draws that verify that **ALL** safeties are met to the Burner Controller and also signal the PLC (Programmable Logic Controller) that enables the AD-464 to begin a drying cycle.

NOTE: Front Lint Drawers and Rear Lint Drawer are not interchangeable.

“B” is used as an electrical interlock to the PLC’s (Programmable Logic Controller’s) 110 VAC output power.

4. Lint Chamber Pressure Switch - PS3

The “Lint Chamber Pressure Sensing Switch” is located on the left rear side of the AD-464 base. It is an Adjustable pressure switch, which incorporate a single-pole-single-throw (SPST) switch. PS3’s electrical function is to close its switch when the “present pressure” in the lint chamber is sufficient. This switch is wired in series with other switches to form an interlock to the Burner Control Module (BCM).

5. Tumbler (Basket) Tilt Problems “LEVEL FAULT”

A “LEVEL FAULT” message is generated by the incorrect state of either the FRONT or REAR sensor switches. The following information will address the “LEVEL” signals, since they are associated with the Base Electrical Junction Box.

a) PROBABLE CAUSES;

1a) Wiring back to the PLC (Programmable Logic Controller)

LS1-B = FRONT DOWN SWITCH

LS2-B = REAR DOWN SWITCH

b) PROBABLE SOLUTIONS;

1b) For a quick check of the FRONT DOWN and REAR DOWN signals to the PLC (Programmable Logic Controller) perform the following:

FRONT DOWN signal test procedure: *paragraph 5a* above

REAR DOWN signal test procedure: *paragraph 5b* above

2b) Place the AD-464 in the LOAD position; Front Up

- Actuate the Front Down switch by hand.
- Have someone verify that PLC (Programmable Logic Controller) input L.E.D. (light emitting diode) #11 lights when the switch actuator is down, and is OFF when the actuator is up.
- Does L.E.D. (light emitting diode) #11 come “ON” when the switch is down?
- If yes, wiring is OK.
- Check switch and actuator placement and tilt actuation.

<p>NOTE: If actuator is at a 90° or greater angle with the base, the actuator will damage if machine is lowered.</p>

- If no, check associated:
- Switch and Wiring
- Check wiring back to the Base Electrical Junction Box
- Check PLC (Programmable Logic Controller)
- Refer to Wiring Diagrams:
 - Main Electrical Panel Diagram
 - Base Electrical Junction Box Wiring Diagram.
- Retest; verify that the signal is operational.

3b) Place the AD-464 in the UNLOAD position; TILTED FORWARD

- Actuate the Rear Down switch by hand.
- Have someone verify that PLC (Programmable Logic Controller) input L.E.D. (light emitting diode) #12 lights when the switch actuator is down, and is OFF when the actuator is up.
- Does L.E.D. (light emitting diode) #12 come “ON” when the switch is down?
- If yes, wiring is OK.
- Check switch, actuator placement and tilt actuation.

NOTE: If actuator is at a 90° or greater angle with the base, the actuator will damage if machine is lowered.

- If no, check associated:
- Switch and Wiring.
- Check wiring back to the Base Electrical Junction Box.
- Check PLC (Programmable Logic Controller).
- Refer to Wiring Diagrams:
 - Main Electrical Panel Diagram
 - Base Electrical Junction Box Wiring Diagram.
- Retest; verify that the signal is operational.

6. Lint Screen Mechanism Problem “SCREEN FAULT”

A “SCREEN FAULT” message is generated by the incorrect state of the lint screen mechanism sensor switch. The following information will address the correct signal, since it is associated with the Base Electrical Junction Box.

a) PROBABLE CAUSES;

1a) *The Lint Screen **must be** cleaned every five (5) drying cycles.*

2a) Wiring back to the PLC (Programmable Logic Controller) 0, 8.

b) PROBABLE SOLUTIONS;

1b) The software has incorporated in it a clean lint screen verification, if the lint screen is not cleaned at the end of five (5) drying cycles. The AD-464 will not allow another drying cycle until the lint screen is cleaned.

2b) A defective lint drawer proximity switch.

- Have someone verify that PLC (Programmable Logic Controller) input L.E.D. (light emitting diode) #8 lights, when the lint drawer is in and off when the drawer is out.
- Does L.E.D. (light emitting diode) #8 come “ON” when the lint drawer is out?
- If yes, wiring is OK
- If no, check associated:
 - Proximity Switches and Wiring
 - Check wiring back to the Base Junction Box.
 - Check PLC (Programmable Logic Controller).
- Refer to Wiring Diagrams:
 - Main Electrical Panel Diagram
 - Base Electrical Junction Box Wiring Diagram.
- Retest; verify that the signal is operational.

7. Lint Chamber Air Pressure Problem “AIR FAULT”

An “AIR FAULT” message is generated by the LINT CHAMBER PRESSURE switch. The following information will address the signal, since it is associated with the Base Electrical Junction Box.

a) PROBABLE CAUSES;

1a) Clogged Lint Screen or Lint Bag

2a) Air Pressure Setting

3a) Air Pressure Switch - PS3 or wiring back to the PLC (Programmable Logic Controller)

b) PROBABLE SOLUTIONS;

1b) Perform preventive maintenance and screen cleaning procedures.

2b) Set correct pressure settings.

3b) For a quick check of the AIR PRESSURE SWITCH WIRING, perform the following:

- Run a drying cycle
- Does the pressure switch’s indicator come “ON”?
- If yes, switch and its adjustment.
- If no, check switch and its adjustment.
 - Verify that PLC (Programmable Logic Controller) input L.E.D. (light emitting diode) #5 comes “ON” L.E.D. (light emitting diode #5 come “ON” when the switch is active?
- If yes, wiring is OK.
- If no, check:
 - Switch, its setting and wiring.
 - Check wiring back to the Base Electrical Junction Box.
 - Check PLC (Programmable Logic Controller).
- Refer to Wiring Diagrams:
 - Main Electrical Panel Diagram
 - Base Electrical Junction Box Wiring Diagram.
- Retest; verify that the signal is operational.

E. PENDANT CONTROL MALFUNCTIONS

Introduction

There are four (4) electrical switches associated with the AD-464 Pendant assembly. These components are interfaced to TB1 of Main Electrical Enclosure through two (2) disconnects and two (2) junction boxes.

The Pendant Assembly is remote control for Loading or Unloading the AD-464. The functions provided are:

- LOAD - LEVEL - UNLOAD
- TUMBLER (Basket) REVERSE
- TUMBLER (Basket) FORWARD
- EMERGENCY STOP (E-Stop)

The following information will provide a means to respond to “Pendant” malfunctions, and to verify **ALL** its electrical signals. Refer to the following AD-464 Pendant associated wiring diagrams for detailed assembly and wiring information.

- AD-464 PENDANT ASSEMBLY DIAGRAM
- AD-464 ANNUNCIATOR, PENDANT, and UPPER RTD’S (Resistive Temperature Device) WIRING DIAGRAM

1. Pendant Electrical Components

- Load - Level - Unload -A and B
- Tumbler (Basket) Reverse Switch - PB2
- Tumbler (Basket) Forward Switch -PB1
- EMERGENCY STOP (E-Stop) Switch - PB6

There are two (2) normally open electrical switches associated with this switch function, that are actuated by a three (3) position selector.

SEL A = LOAD

SEL B = UNLOAD

Once this switch turned to “LOAD”, the dryer’s front doors will open, and depending upon system configuration, will either tilt back or remain level.

- If the AD-464 was configured to Unload from the front: Any time this switch is turned to “UNLOAD,” the dryer’s front doors will open, and its tumbler (basket) will tilt to the front.
- If the AD-464 was configured to Unload from the rear: Anytime this switch turned to “UNLOAD,” ***nothing will happen.*** **ALL** unloading functions will be transferred to the rear Control Panel.
- TUMBLER (Basket) REVERSE “PENDANT” - PB2

This push button comprises of one normally open switch, and is mechanically interlocked with the Tumbler (Basket) Forward Push-button.

- TUMBLER (Basket) FORWARD “PENDANT” - PB1

This push button comprises of one normally open switch, and is mechanically interlocked with the Tumbler (Basket) Reverse Push button.

- EMERGENCY STOP ((E-Stop) “PENDANT” - PB6

This push button switch is normally open device and its function is to shut down the control voltage to the dryer in the event it is pressed.

NOTE: It will not effect the sprinkler circuit power.

2. Verify Pendant Electrical Signals

ALL the pendant control signals are interfaced to the Main Electrical Panel’s PLC (Programmable Logic Controller) except for EMERGENCY STOP (E-Stop).

- Load - Level - Unload -A and B
- Tumbler (Basket) Reverse Switch - PB2
- Tumbler (Basket) Forward Switch -PB1
- EMERGENCY STOP (E-Stop) Switch - PB6

For a quick check of the wiring of SEL 1 and 2 to the PLC (Programmable Logic Controller) perform the following test with the control voltage “ON” (“GREEN” Button);

- Turn the selector switch to “LOAD.”
 - Does PLC (Programmable Logic Controller) input L.E.D. (light emitting diode) #15 light?
- Turn the selector switch to “UNLOAD.”
 - Does PLC (Programmable Logic Controller) input L.E.D. (light emitting diode) #16 light?
- Turn the selector switch to “LEVEL.”
 - Are both PLC (Programmable Logic Controller) (input #15 and input #16) “OFF”?
- If the answers to these question are “YES,” wiring to the PLC (Programmable Logic Controller) is correct.

If any answer to these questions is “NO”, refer to *Probable Causes paragraph* on **page 89**.

- Tumbler (Basket) Reverse Switch PB2

For a quick check of the wiring of PB2 to the PLC (Programmable Logic Controller) perform the following test with control voltage “ON”. (“GREEN” Button)

- Press the REVERSE push-button.
 - Does PLC (Programmable Logic Controller) input L.E.D. (light emitting diode) #18 light?

- Releases the REVERSE Push-button.
 - Does PLC (Programmable Logic Controller) input L.E.D. (light emitting diode) #18 go “OFF”?
- If the answers to these question are “YES”, wiring to the PLC (Programmable Logic Controller) is correct.

If any answer to these questions is “NO”, refer to *Probable Causes paragraph* below

- Tumbler (Basket) Forward Switch - PB1

For quick check of the wiring of PB1 to the PLC (Programmable Logic Controller) perform the following test with the control voltage “ON”. (“GREEN” Button)

- Press the FORWARD Push-button.
 - Does PLC (Programmable Logic Controller) input L.E.D. (light emitting diode) #17 light?
- Releases the REVERSE Push-button.
 - Does PLC (Programmable Logic Controller) input L.E.D. (light emitting diode) #17 go “OFF”?
- If the answer to these question are “YES,” wiring to the PLC (Programmable Logic Controller) is correct.

If any answer to these questions is “NO,” refer to *Probable Causes paragraph* below:

a) PROBABLE CAUSES;

1a) Fuse #4 on Main Electrical Panel

2a) Faulty Switches

3a) Wiring back to the PLC (Programmable Logic Controller)

b) POSSIBLE SOLUTIONS;

1b) Check fuse blown indicator on Fuse #4; replace fuse, if necessary and retest.

2b) Check switches using an OHM meter; replace if necessary, and retest.

3b) Refer to AD-464 Pendant associated wiring diagrams for detailed assembly and wiring information. Check **ALL** circuits back to PLC (Programmable Logic Controller).

- AD-464 PENDANT ASSEMBLY DIAGRAM
- AD-464 ANNUNCIATOR, PENDANT, and UPPER RTD’S (Resistive Temperature Device’s) WIRING DIAGRAM

3. EMERGENCY STOP (E-Stop) SWITCH - PB6

If the EMERGENCY STOP (E-Stop) - pendant - does not respond:

a) PROBABLE CAUSES;

- 1a) Another EMERGENCY STOP (E-Stop) Button
- 2a) A Disconnect Plug
- 3a) Faulty Switch
- 4a) Wiring Back To TB1

b) POSSIBLE SOLUTIONS;

- 1b) Verify that **ALL** other EMERGENCY STOP (E-Stop) buttons are pushed in, and Retest.
- 2b) Verify that **ALL** of the Pendant's disconnect plugs are indeed connected. The disconnect plugs are for removal of the Pendant arm for shipping.
- 3b) With the control voltage off, open pendant assembly and check switch using an OHM meter; replace if defective.
- 4b) Locate terminal #14 and terminal #15 on TB1 on the bottom of the main electrical enclosure. Open their associated disconnects and place an OHM meter across these terminals. Push the EMERGENCY STOP (E-Stop) button in. Does the OHM meter respond.
 - If YES, wiring to TB1 is correct, check wiring on the main electrical panel, then retest.
 - If NO, wiring from the pendant to TB1 is incorrect. Check wiring using the appropriated wiring diagrams listed above, and retest.

F. TEMPERATURE SENSING

Introduction

There is one (1) temperature sensing and controlling device in the AD-464 located in the exhaust. The temperature sensing device is a RTD (Resistance Temperature Device), whose resistance changes with temperature. The temperature information from each RTD's (Resistive Temperature Device) is forwarded to a respective 4 to 20 milliampere (4 to 20 mA) transmitter located on the Main Electrical Enclosure Panel. The converted signal is then connected PLC's (Resistive Temperature Device) analog input module for further processing.

The following information will provide a means to respond to “Temperature Sensing” malfunctions, and verify ALL its electrical signals. Refer to the following diagrams for detail placement and wiring information.

- AD-464 ANNUNCIATOR, PENDANT, and UPPER RTD’S (Resistance Temperature Device) WIRING DIAGRAM
- AD-464 MAIN PANEL WIRING DIAGRAM
- AD-464 SYSTEM BLOCK DIAGRAM

1. TEMPERATURE SENSING COMPONENT DESCRIPTIONS

- Exhaust RTD (Resistance Temperature Device)- Sens1

The RTD (Resistance Temperature Device), used throughout the AD-464 are identical. The main function is to measure temperatures and to transfer this information to a measuring devices for further processing. The RTD used on the AD-464 are rated for 1100° F (593.3° C).

- Sens1 = Exhaust Temperature Sensor

The exhaust RTD (Resistance Temperature Device) is located in the AD-464 burner area exhaust duct and also has electrical disconnects in a junction box for ease of replacement.

- Exhaust 4 to 20 milliampere (4 to 20 mA) transmitter - Trans1

This transmitter is located on the upper right of the main electrical enclosure panel. The exhaust RTD (Resistance Temperature Device) is connected in series with a 24 volt DC power supply, and the current drawn from the power supply is 4 to 20 milliampere (4 to 20 mA) output signal which is proportional to the input signal. The proportional current information is the connected to the PLC (Programmable Logic Controller) for processing. Refer to the AD-464 Ladder Diagram for circuit information.

- 24 Volt DC Power Supply

The 24 volt power supply used in the AD-464 is an individual grade switching power supply, rated for 120 volts AC input and 24 volts DC output. Features this device incorporates are:

- Overload protection to protect the load
- Internal failure protection to protect itself
- An output status indicator; this L.E.D. (light emitting diode) indicates the presence of DC output voltage.

- PLC (Programmable Logic Controller) Analog Input Module - Module #2

This device, attached to the PLC , receives the 4 to 20 milliampere (4 to 20 mA) temperature information and processes this information for the PLC.

- Temperature Measurement and Sensing Problems

An “EXHAUST DSFL” MESSAGE is displayed on the operator terminal any time a respective temperature measurement has exceeded the programmed temperature in the PLC (Programmable Logic Controller). A “DSFL” message will stop the current drying cycle and prevent a drying cycle from starting.

2. “EXHAUST DSFL” MESSAGE

a) PROBABLE CAUSES;

- 1a) Defective RTD (Resistive Temperature Device) Probe
- 2a) Defective 24 Volt DC Power Supply
- 3a) Defective Analog Input Module For Channel
- 4a) RTD (Resistive Temperature Device) Wiring To The “EXHAUST” 4 to 20 Milliamphere (4 to 20 mA) Transmitter
- 5a) Circuit Wiring To the Analog Input Module

b) POSSIBLE SOLUTIONS;

1b) With the control voltage “OFF.”

The exhaust RTD (Resistive Temperature Device) probe can be quickly checked, by locating its labeled disconnect in the right hand wire which is located on the main electrical enclosure panel. Disconnect this plug and measure the resistance of the two wires coming from the RTD; it **should be** in the 100 ohm (100 Ω) range.

- If resistance is within range, wiring and RTD are OK.
- If the resistance is infinite (no measurements), or zero ohms (1 Ω) , go directly to the intake RTD (Resistive Temperature Device) disconnect box and measure the RTD’s resistance directly.
- If the RTD resistance measurements is acceptable, check circuit wiring.
- If the RTD resistance measurements is not acceptable; replace RTD and retest

2b) Defective 24 Volt DC Power Supply

With the control voltage “ON,” check that 120 volts AC is applied to the device’s AC input.

- If no voltage check fuse #8, and wiring and retest.

Check that the device’s DC output indicator is “ON.”

- If “OFF”, this indicates that there is no 24 volts DC output.

Disconnect the output voltage wires connected to the power supply and notice if the L.E.D. (light emitting diode) indicator responds.

- If the power supply responds to the disconnection, there is a problem with the driven load and not the power supply itself.
- Check **ALL** loads and retest.

Check that the device's output voltage is 24 volts DC.

- If not, adjust it.

3. DEFECTIVE ANALOG INPUT MODULE or CHANNEL

Replace Analog Input Module

4. RTD (Resistive Temperature Device) WIRING TO THE "EXHAUST" 4 to 20 MILLIAMPERE (4 to 20 mA) TRANSMITTER

Check **ALL** wiring and AD-464 connection from the exhaust RTD (Resistive Temperature Device) probe to the exhaust 4 to 20 milliampere (4 to 20 mA) transmitter. Refer to the AD-464 EXHAUST Temperature Assembly and Wiring Diagram, AD-464 Main Panel Wiring Diagram.

5. CIRCUIT WIRING TO THE ANALOG INPUT MODULE

Check **ALL** wiring and connections from the 4 to 20 milliampere (4 to 20 mA) transmitter to the PLC (Programmable Logic Controller) Analog Input Module. Refer to the AD-464 Main Panel Wiring Diagram.

G. MOTORS

Introduction

The four (4) motors installed on the AD-464 are connected directly to associated thermal magnetic starters in the main electrical enclosure. The troubleshooting information included in this section will cover the actuation, power control and safety devices to these motors.

The AD-464 motors include:

- MAIN BLOWER FAN MOTOR
- BURNER FAN MOTOR
- LEFT (Basket) TUMBLER MOTOR
- RIGHT (Basket) TUMBLER MOTOR

Refer to the following diagrams for functional, and wiring information:

- AD-464 MAIN PANEL WIRING DIAGRAM
- AD-464 SYSTEM BLOCK DIAGRAM
- Motor Actuating Device Information

ALL AD-464 motor contactors have 120 volts 50/60 Hz actuation coils. Three (3) motor contactors are actuated by outputs from the PLC (Programmable Logic Controller), and one contactor is actuated by the Burner Controller Module (BCM).

- Motor Protection Device Descriptions

The motor protection devices in the AD-464 incorporate a manual disconnect switch, thermal overload relay, and instantaneous trip mechanism in one compact device. A two (2) position, normally open, ~~auxiliary contact block has been attached to~~ ALL motor protection devices to provide the “MOTOR FAULT” display message, and shut down “ALL” motors in the event a motor should trip.

1. Motor Actuation Problems

a) PROBABLE CAUSES;

- 1a) Motor Protection Device “OFF” or “TRIPPED.”
- 2a) PLC (Programmable Logic Controller) Output Signal Defective
- 3a) Motor Circuit Wiring

b) PROBABLE SOLUTIONS;

- 1b) Verify that all motor protection devices (manual starters) have their “START” buttons pushed in. If any device has tripped, reset it and restart the dryer. If the same devices continue to trip:
 - Verify current setting
 - Check circuit
 - Check motor
 - Retest
- 2b) Verify that the associated output L.E.D. (light emitting diode) on the PLC (Programmable Logic Controller) is active. Verify that the associated output signal protection fuse is good. Check associated PLC output circuit wiring to associated motor starter coil (“A” terminals).
- 3b) Retest
- 4b) Check associated motor starter circuit wiring to and from motor starters, and to the associated motors themselves. Refer to the AD-464 Main Panel Wiring Diagram; retest.

H. PLC (Programmable Logic Controller) ERROR MESSAGES

The AD-464 diagnostics messages have been provided to aid troubleshooters in diagnosing and repairing dryer problems. The messages are intended to direct one to a particular fault area for further testing; not to diagnose the machine for you.

NOTE: Not **ALL** AD-464 dryer symptoms have faults messages.

The following information describes the action the AD-464 will take while displaying a particular message.

ERROR MESSAGES	AD-464 IDLING	AD-464 RUNNING
CTRL VOLT OFF	Cannot operate machine	Stops dryer
INTAKE	Cannot operate machine	Stops dryer
EXHAUST DSFL	Cannot operate machine	Stops dryer
DOOR OPEN	Cannot operate machine	Stops dryer
SCREEN FAULT	Cannot operate machine	Stops dryer
MOTOR FAULT	Cannot operate machine	Stops dryer
GAS FAULT	Not Applicable	Burner Controller stops heat
AIR FAULT	Not Applicable	Burner Controller stops heat
HEATER FAULT	Not Applicable	Burner Controller stops heat
HI-TEMP FAULT	Not Applicable	Burner Controller stops heat
DRUM FAULT	Not Applicable	Burner Controller stops heat
LEVEL FAULT	Cannot operate machine	Stops dryer
LINE FAULTS*	Cannot operate machine	Cannot operate machine

* This message is generated by the operator terminal itself; it indicates that communication between the operator terminal and PLC (Programmable Logic Controller) have discontinued.

ADC 112193 1- 01/11/96-25 2* 10/18/96-25 3* 01/07/97-50
4* 08/25/99-25 5* 12/30/99-25 6* 08/09/01-25

