

AD222

Installation/Operator Manual

WARNING: For your safety the information in this manual must be followed to minimize the risk of fire or explosion and to prevent property damage, personal injury or death.

— Do not store or use gasoline or other flammable vapors and liquids in the vicinity of this or any other appliance.

— **WHAT TO DO IF YOU SMELL GAS:**

- Do not try to light any appliance.
- Do not touch any electrical switch; do not use any phone in your building.
- Clear the room, building or area of all occupants.
- Immediately call your gas supplier from a neighbor's phone. Follow the gas supplier's instructions.
- If you cannot reach your gas supplier, call the fire department.

— Installation and service must be performed by a qualified installer, service agency or the gas supplier.

AVERTISSEMENT: Assurez-vous de bien suivre les instructions données dans cette notice pour réduire au minimum le risque d'incendie ou d'explosion ou pour éviter tout dommage matériel, toute blessure ou la mort.

— Ne pas entreposer ni utiliser d'essence ni d'autres vapeurs ou liquides inflammables à proximité de cet appareil ou de tout autre appareil.

— **QUE FAIRE SI VOUS SENTEZ UNE ODEUR DE GAZ:**

- Ne pas tenter d'allumer d'appareils.
- Ne touchez à aucun interrupteur. Ne pas vous servir des téléphones se trouvant dans le bâtiment.
- Évacuez la pièce, le bâtiment ou la zone.
- Appelez immédiatement votre fournisseur de gaz depuis un voisin. Suivez les instructions du fournisseur.
- Si vous ne pouvez rejoindre le fournisseur de gaz, appelez le service des incendies.

— L'installation et l'entretien doivent être assurés par un installateur ou un service d'entretien qualifié ou par le fournisseur de gaz.



American Dryer Corporation
88 Currant Road
Fall River MA 02720-4781 USA
Telephone: +1 (508) 678-9000 / Fax: +1 (508) 678-9447
e-mail: techsupport@amdry.com

www.amdry.com

ADC Part No. 112217-2

Retain This Manual in a Safe Place for Future Reference

This product embodies advanced concepts in engineering, design, and safety. If this product is properly maintained, it will provide many years of safe, efficient, and trouble free operation.

Only qualified technicians should service this equipment.

OBSERVE ALL SAFETY PRECAUTIONS displayed on the equipment or specified in the installation manual included with the dryer.

The following "FOR YOUR SAFETY" caution must be posted near the dryer in a prominent location.

FOR YOUR SAFETY

Do not store or use gasoline or other flammable vapors and liquids in the vicinity of this or any other appliance.

POUR VOTRE SÉCURITÉ

Ne pas entreposer ni utiliser d'essence ni d'autres vapeurs ou liquides inflammables à proximité de cet appareil ou de tout autre appareil.

We have tried to make this manual as complete as possible and hope you will find it useful. The manufacturer reserves the right to make changes from time to time, without notice or obligation, in prices, specifications, colors, and material, and to change or discontinue models. The illustrations included in this manual may not depict your particular dryer exactly.

IMPORTANT

For your convenience, log the following information:

DATE OF PURCHASE _____ MODEL NO. AD222

RESELLER'S NAME _____

SERIAL NUMBER(S) _____

Replacement parts can be obtained from your reseller or the ADC factory. When ordering replacement parts from the factory, you can FAX your order to ADC at +1 (508) 678-9447 or telephone your order directly to the ADC Parts Department at +1 (508) 678-9000. Please specify the dryer model number and serial number in addition to the description and part number, so that your order is processed accurately and promptly.

These instructions are only valid if the following country code is on the appliance... If this code is not present on the appliance, it is necessary to refer to the technical instructions which will provide the necessary information concerning the modification of the appliance to the condition of use for the country.

In accordance with EN ISO 3166-1, the names of countries shall be represented by the following codes:

GB United Kingdom
IE Ireland

"IMPORTANT NOTE TO PURCHASER"

Information must be obtained from your local gas supplier on the instructions to be followed if the user smells gas. These instructions must be posted in a prominent location near the dryer.

WARNING

Proposition 65

Use of this product could expose you to substances from fuel combustion that contain chemicals known to the State of California to cause cancer, birth defects and other reproductive harm.

IMPORTANT

You must disconnect and lockout the electric supply and the gas supply or the steam supply before any covers or guards are removed from the machine to allow access for cleaning, adjusting, installation, or testing of any equipment per OSHA standards.

Please observe all safety precautions displayed on the equipment and/or specified in the installation manual included with the dryer.

Before installation, check that the local distribution conditions, nature of gas and pressure, and adjustment of the appliances are compatible.

CAUTION

Dryer(s) should never be left unattended while in operation.

“Caution: Label all wires prior to disconnection when servicing controls. Wiring errors can cause improper operation.”

«Attention: Au moment de l'entretien des commandes, étiquetez tous les fils avant de les débrancher. Des erreurs de câblage peuvent entraîner un fonctionnement inadéquat et dangereux.»

WARNING

Children should not be allowed to play on or near the dryer(s). Children should be supervised if near dryer(s) in operation.

Under no circumstances should the dryer door switch(es), lint door/drawer switch(es), or heat safety circuit(s) ever be disabled.

Do not modify this appliance.

The dryer must never be operated with any of the back guards, outer tops, or service panels removed. Personal injury or fire could result.

The dryer must never be operated without the lint filter/screen in place, even if an external lint collection system is used.

If the hi-limit switch trips, a service call is required to investigate the reason and resolve the issue.

FOR YOUR SAFETY

Do not dry mop heads in the dryer. Do not use dryer in the presence of dry cleaning fumes.

The dryers must not be installed or stored in an area where it will be exposed to water and/or weather.

The wiring diagram for the dryer is located behind the control panel.

In the State of Massachusetts, the following installation instructions apply:

- Installations and repairs must be performed by a qualified or licensed contractor, plumber, or gasfitter qualified or licensed by the State of Massachusetts.
- If using a ball valve, it shall be a T-handle type.
- A flexible gas connector, when used, must not exceed 3 feet.

Table of Contents _____

Safety Precautions	4
Specifications	6
Installation Procedures	8
Location Requirements	8
Unpacking/Setting Up	8
Dryer Enclosure Requirements	8
Fresh Air Supply Requirements	9
Exhaust Requirements	9
Electrical Information	11
Gas Information	12
Converting from One Family of Gas to Another	14
Preparation for Operation/Start-Up	16
Preoperational Test	16
Preoperational Instructions	17
Shutdown Instructions	17
Service / Parts Information	17
Service	17
Parts	17
Warranty Information	17
Returning Warranty Cards	17
Warranty	18
Returning Warranty Parts	18
Routine Maintenance	18
Data Label Information	19

List of Acronyms _____

HVAC	Heating, Ventilating, and Air-Conditioning
in WC	Inches of Water Column
L.C.D.	Liquid Crystal Display
L.E.D.	Light Emitting Diode
L.P.	Liquid Propane
OSHA	Occupational Safety and Health Administration
R.M.A.	Return Material Authorization
UL	Underwriters Laboratory

Safety Precautions

WARNING

For your safety, the information in this manual must be followed to minimize the risk of fire or explosion and to prevent property damage, personal injury, or loss of life.

The dryer must never be operated with any of the back guards, outer tops, or service panels removed. Personal injury or fire could result.

Failure to properly install, maintain, and/or operate dryer according to this manual and operator's manuals included with dryer may result in conditions, which can cause serious injury, death and/or property damage.

Do not store or use gasoline or other flammable vapors and liquids in the vicinity of this or any other appliance.

Do not spray aerosols in the vicinity of this appliance while it is in operation.

Purchaser and user should consult the local gas supplier for proper instructions to be followed in the event the user smells gas. The instructions should be posted in a prominent location.

What To Do If You Smell Gas:

- Do not try to light any appliance.
- Do not touch any electrical switch.
- Do not use any phone in your building.
- Clear the room, building, or area of all occupants.
- Immediately call your gas supplier from a neighbor's phone. Follow the gas supplier's instructions.
- If you cannot reach your gas supplier, call the fire department.

Installation and service must be performed by a qualified installer, service agency, or gas supplier.

Dryers must be exhausted to the outdoors.

Although the manufacturer produces a very versatile dryer, there are some articles that, due to fabric composition or cleaning method, should not be dried in it.

WARNING

Dry only water washed fabrics. Do not dry articles spotted or washed in dry cleaning solvents, combustible detergents, or "all purpose" cleaner. Explosion could result.

Do not dry rags or articles coated or contaminated with gasoline, kerosene, oil, paint, or wax. Explosion could result.

Items that have been spotted or soaked with vegetable or cooking oil constitute a fire hazard and should not be placed in a tumble dryer.

Do not dry mop heads. Contamination by wax or flammable solvents will create a fire hazard.

WARNING

Do not use heat for drying articles that contain plastic, foam, sponge rubber, or similarly textured rubber materials. Drying in a heated tumbler may damage plastics or rubber and also may be a fire hazard.

A program should be established for the inspection and cleaning of lint in the burner area, exhaust ductwork, and area around the back of the dryer. The frequency of inspection and cleaning can best be determined from experience at each location.

Do not operate steam dryers with more than 150 psi (10.34 bar) steam pressure. Excessive steam pressure can damage the steam coil and/or harm personnel.

Replace leaking flexible hoses or other steam fixtures immediately. Do not operate the dryer with leaking flexible hoses. Personal injury may result.

WARNING

The collection of lint in the burner area and exhaust ductwork can create a potential fire hazard.

For personal safety, the dryer must be electrically grounded in accordance with local codes and/or the National Electrical Code ANSI/NFPA NO. 70-LATEST EDITION or in Canada, the Canadian Electrical Codes Parts 1 & 2 CSA C22.1-1990 or LATEST EDITION.

NOTE: Failure to electrically ground the dryer properly will void the warranty.

WARNING

Personal injury or fire could result should the dryer door switch, lint door/drawer, or heat safety circuit ever be disabled.

Remove articles from the dryer as soon as the drying cycle has been completed.

WARNING

Articles left in the dryer after the drying and cooling cycles have been completed can create a fire hazard.

For safety, proper operation, and optimum performance, the dryer must not be operated with a load less than 66% of its rated capacity.

WARNING

You must disconnect and lockout the electric supply and the gas supply or the steam supply before any covers or guards are removed from the machine to allow access for cleaning, adjusting, installation, or testing of any equipment per OSHA standards.

IMPORTANT: The dryer must be installed in a location/ environment, which the ambient temperature remains between 40° F (4.44° C) and 130° F (54.44° C).

The operation of this appliance may affect the operation of other types of gas appliances, which take their air for safe combustion from the same room. If in doubt, consult the appliance manufacturer(s).

Use this dryer only for its intended purpose, drying fabrics.

The “cool down” cycle of tumble dryers should be used to reduce the temperature of the items. They should not be removed from the tumble dryer or piled or stacked while hot.

Fabric softeners or similar products should not be used in a tumbler dryer to eliminate the effects of static electricity unless this practice is specifically recommended by the manufacturer of the fabric softener or product.

⚠ WARNING

To reduce the risk of personal injury, install lockable doors to prevent public access to the rear of the dryers.

Exhaust duct outlet should be checked periodically for blockages, and if any found, removed.

IMPORTANT: A means of restraint must be used to prevent straining of the gas supply when the appliance is moved.

An external means of power removal (disconnect device) must be provided by the installer.

CE ONLY

IMPORTANT: This appliance must only be installed and operated in the country of destination indicated on the dryer's data plate. If the appliance is to be installed and operated in a country other than the one indicated on the data plate, a data plate amendment must be obtained from American Dryer Corporation.

⚠ WARNING

This appliance must only operate with the gas type indicated on the dryer's data plate. If the appliance is converted (gas type is changed), a data plate amendment must be obtained from American Dryer Corporation.

This appliance may cause spillage of products of combustion from an open-flue appliance fitted in the same room, and that such an appliance shall be tested for clearance of products with the appliance in operation and all windows and doors closed.

NOTES _____

Specifications

MAXIMUM CAPACITY (DRY WEIGHT) PER POCKET		22 lb	9.98 kg	
TUMBLER DIAMETER		25-3/4"	65.41 cm	
TUMBLER DEPTH		24-3/4"	62.86 cm	
TUMBLER VOLUME PER POCKET		7-1/2 cu ft	212.38 L	
TUMBLER/DRIVE MOTOR PER POCKET		1/3 hp	0.25 kW	
BLOWER/FAN MOTOR PER POCKET		BLOWER DRIVEN BY TUMBLER MOTOR		
DOOR OPENING (DIAMETER)		21-1/2"	54.6 cm	
DOOR SILL HEIGHT TOP POCKET / BOTTOM POCKET		50-1/2" / 12-1/2"	128.27 cm / 31.75 cm	
WATER CONNECTION		N / A		
DRYERS PER 20'/40' CONTAINER		42 / 84		
DRYERS PER 48'/53' TRUCK		96 / 108		
Gas	VOLTAGE AVAILABLE		120V 1 ϕ 2w 60 Hz	
	APPROXIMATE NET WEIGHT		302 lb 136.98 kg	
	APPROXIMATE SHIPPING WEIGHT		342 lb 155.12 kg	
	AIRFLOW PER POCKET		220 cfm 6.23 cmm	
	HEAT INPUT PER POCKET		26,000 Btu/hr 6,550 kcal/hr	
	EXHAUST CONNECTION (DIAMETER) PER POCKET		4" 10.16 cm	
	COMPRESSED AIR CONNECTION		N / A	
	COMPRESSED AIR VOLUME		N / A	
INLET PIPE CONNECTION PER POCKET		3/8" M.N.P.T.		
Electric	VOLTAGE AVAILABLE		208-240V 1 ϕ 50/60 Hz	
	APPROXIMATE NET WEIGHT		302 lb 136.98 kg	
	APPROXIMATE SHIPPING WEIGHT		342 lb 155.12 kg	
	AIRFLOW PER POCKET		220 cfm 6.23 cmm	
	EXHAUST CONNECTION (DIAMETER) PER POCKET		4" 10.16 cm	
	COMPRESSED AIR CONNECTION		N / A	
	COMPRESSED AIR VOLUME		N / A	
	OVEN SIZE PER POCKET			
	kW	Btu/hr	kcal/hr	
	4.1	13,843	3,488	
5.0	17,065	4,300		
5.4	18,430	4,644		
Steam	VOLTAGE AVAILABLE		N / A	
	APPROXIMATE NET WEIGHT			
	APPROXIMATE SHIPPING WEIGHT			
	AIRFLOW PER POCKET			
	STEAM CONSUMPTION PER POCKET			
	OPERATING STEAM PRESSURE			
	EXHAUST CONNECTION (DIAMETER) PER POCKET			
	COMPRESSED AIR CONNECTION			
	COMPRESSED AIR VOLUME			
	BOILER HORSEPOWER (NORMAL LOAD) PER POCKET			
	SUPPLY CONNECTION PER POCKET			
	RETURN CONNECTION PER POCKET			

Shaded areas are stated in metric equivalents

11/30/11

NOTE: The manufacturer reserves the right to make changes in specifications at any time without notice or obligation.

Specifications

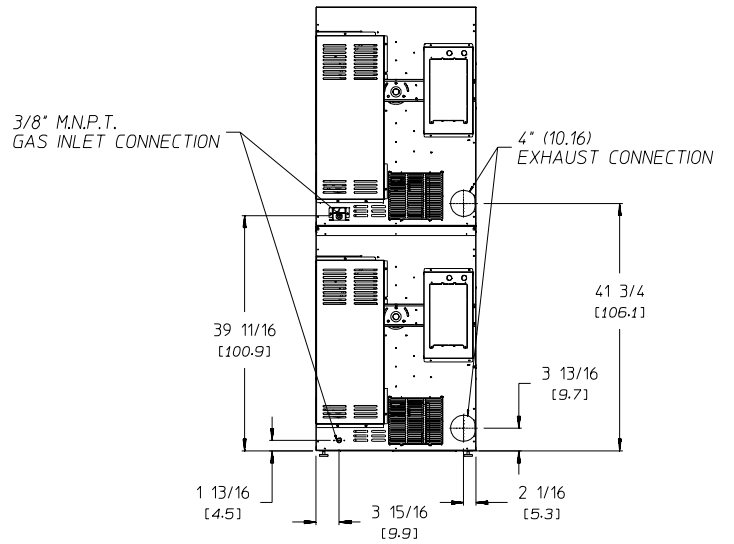
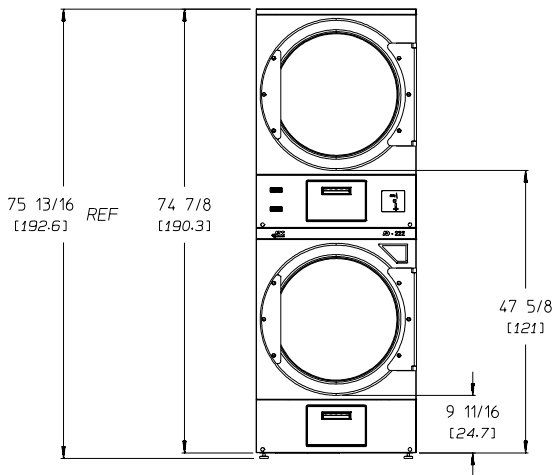
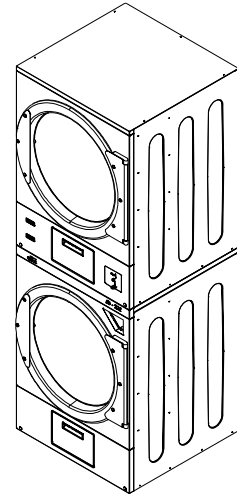
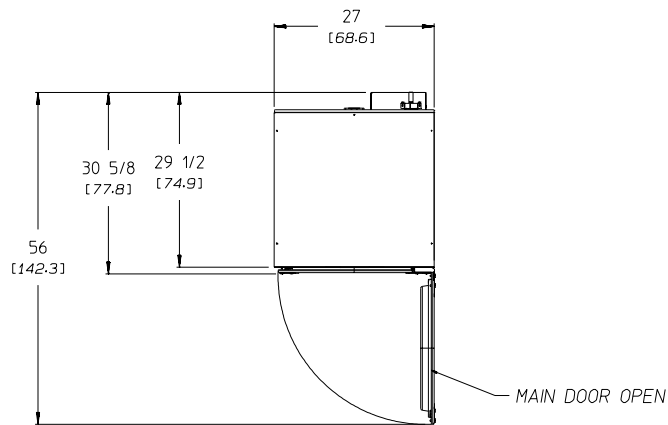

NOTE: The manufacturer reserves the right to make changes in specifications at any time without notice or obligation.

Installation Procedures

Installation should be performed by competent professional in accordance with local, state, and country codes. In the absence of these codes, the installation must conform to applicable American National Standards: ANSI Z223.1-LATEST EDITION (National Fuel Gas Code) or ANSI/NFPA NO. 70-LATEST EDITION (National Electrical Code) or in Canada, the installation must conform to applicable Canadian Standards: CAN/CGA-B149.1-M91 (Natural Gas) or CAN/CGA-B149.2-M91 (L.P. Gas) or LATEST EDITION (for General Installation and Gas Plumbing) or Canadian Electrical Codes Parts 1 & 2 CSA C22.1-1990 or LATEST EDITION (for Electrical Connections).

Location Requirements

Before installing the dryer, be sure the location conforms to local codes and ordinances. In the absence of such codes or ordinances the location must conform with the National Fuel Gas Code ANSI.Z223.1 LATEST EDITION, or in Canada, the installation must conform to applicable Canadian Standards: CAN/CGA-B149.1-M91 (Natural Gas) or CAN/CGA-B149.2-M91 (L.P. Gas) or LATEST EDITION (for General Installation and Gas Plumbing).

The dryer must be installed on a sound level floor capable of supporting its weight. Carpeting must be removed from the floor area that the dryer is to rest on.

The dryer must not be installed or stored in an area where it will be exposed to water and/or weather.

Provisions for adequate air supply must be provided as noted in this manual (refer to Fresh Air Supply Requirements section).

Clearance provisions must be made from combustible construction as noted in this manual (refer to Dryer Enclosure Requirements section).

Provisions must be made for adequate clearances for servicing and for operation as noted in this manual (refer to Dryer Enclosure Requirements section).

The dryer must be installed with a proper exhaust duct connection to the outside as noted in this manual (refer to Exhaust Requirements section).

The dryer must be located in an area where correct exhaust venting can be achieved as noted in this manual (refer to Exhaust Requirements section).

IMPORTANT: The dryer should be located where a minimum amount of exhaust ducting will be necessary.

The dryer must be installed with adequate clearance for air openings into the combustion chamber.

CAUTION: This dryer produces combustible lint and must be exhausted to the outdoors. Every 6 months, inspect the exhaust ducting and remove any lint buildup.

IMPORTANT: The dryer must be installed in a location/environment, which the ambient temperature remains between 40° F (4.44° C) and 130° F (54.44° C).

Unpacking/Setting Up

Remove protective shipping material (i.e., plastic wrap and optional shipping box) from the dryer.

IMPORTANT: Dryer must be transported and handled in an upright position at all times.

The dryer can be moved to its final location while still attached to the skid or with the skid removed.

With the skid removed, use caution and assure all four leveling legs are fully retracted, if the dryer is to be slid into its final position.

Leveling Dryer

The dryer is equipped with 4 leveling legs, 1 at each corner of the base. For optimum performance the dryer should be level front-to-back and side-to-side.

Dryer Enclosure Requirements

Bulkheads and partitions should be made of noncombustible material.

NOTE: Allowances must be made for opening the control door.

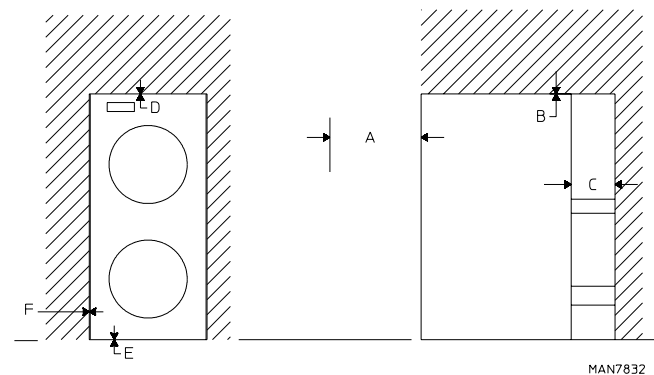

- A The requirement to allow the door to open completely is 28-inches (71.12 cm).
- B A minimum overhead clearance of 6-inches (15.24 cm) is required.
- C Dryer should be positioned a minimum of 12-inches (30.48 cm) away from the nearest obstruction. 24-inches (60.96 cm) is recommended for ease of installation, maintenance, and service.
- D 1/16" (1.5875 mm) minimum is required.
- E Flooring should be level or below dryer cabinet for ease of removing panels during maintenance.
- F Dryers may be positioned sidewall to sidewall, however a 1/16" (1.5875 mm) minimum allowance must be made for the opening and closing of the control door, along with the removal of panels during maintenance.

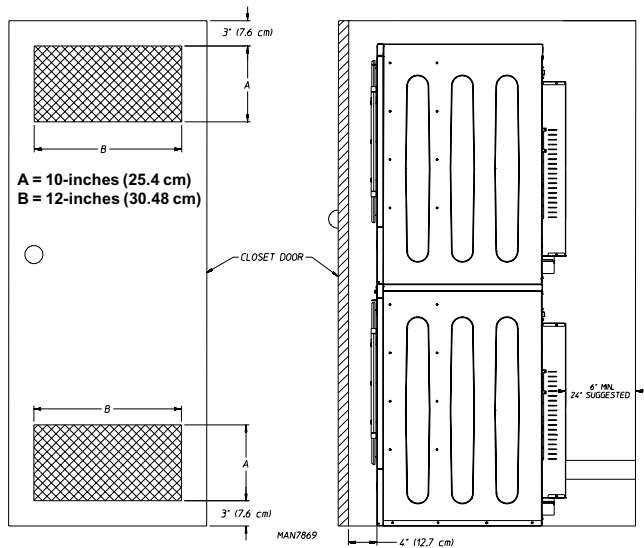

EXAMPLE: Two unrestricted openings measuring 10-inches by 12-inches (25.4 cm by 30.48 cm) are acceptable.

If a closet door is installed: unobstructed air openings are required. The air openings shall be located 3-inches (7.62 cm) from the lower opening (above floor level) and upper opening (below ceiling). The total free area of the air openings in the door shall not be less than 130 inch² (838.708 cm²). Louvered doors with equivalent air openings are acceptable.

No other fuel-burning appliance shall be installed in the same closet as the dryer.

Fresh Air Supply Requirements

When the dryer is operating, it draws in room air, heats it, passes this air through the tumbler, and exhausts it out of the building. Therefore, the room air must be continually replenished from the outdoors. If the make-up air is inadequate, drying time and drying efficiency will be adversely affected. Ignition problems and sail switch "fluttering" problems may result, as well as premature motor failure from overheating. The dryer must be installed with provisions for adequate combustion and make-up air supply.

Air supply (make-up air) must be given careful consideration to ensure proper performance of each dryer. Fresh air ventilation openings shall not be blocked and/or sealed. As a general rule, an unrestricted air entrance from the outdoors of 52 inch² (335 cm²) is required for each dryer. (Based on 1 inch² [6.5 cm²] per 1,000 Btu [252 kcal].)

It is not necessary to have a separate make-up air opening for each dryer. Common make-up air openings are acceptable. However, they must be set up in such a manner that the make-up air is distributed equally to all the dryers.

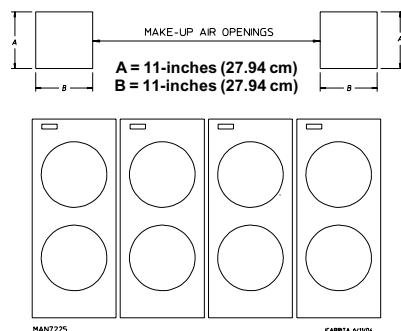

EXAMPLE: For a bank of 4 dryers, 2 unrestricted openings measuring 11-inches by 11-inches (27.94 cm by 27.94 cm) are acceptable.

To compensate for the use of registers or louvers used over the openings, this area must be increased by approximately 33%. Make-up air openings should not be located in an area directly near where exhaust vents exit the building.

Allowances must be made for remote or constricting passageways or where dryers are located at high altitudes or predominantly low pressure areas.

IMPORTANT: Make-up air must be free of dry cleaning solvent fumes. Make-up air that is contaminated by dry cleaning solvent fumes will result in irreparable damage to the motors and other dryer components.

NOTE: Component failure due to dry cleaning solvent fumes will void the warranty.

Exhaust Requirements

Exhaust ductwork should be designed and installed by a qualified professional. Improperly sized ductwork will create excessive back pressure, which results in slow drying, increased use of energy, and shutdown of the burner by burner hi-limits, or lint chamber hi-limit protector thermostat. The dryer must be installed with a proper exhaust duct connection to the outside.

The design of the flue system shall be such that any condensate formed when operating the appliance from cold shall either be retained and subsequently re-evaporated or discharged.

CAUTION: This dryer produces combustible lint and must be exhausted to the outdoors.

Improperly sized or installed exhaust ductwork can create a potential fire hazard.

The ductwork should be laid out in such a way that the ductwork travels as directly as possible to the outdoors with as few turns as possible. There should be a minimum 6-inch (15.24 cm) clearance between the back guard and the first bend in the ductwork for ease of servicing. Single or independent dryer venting is recommended. It is suggested that the use of 90° turns be avoided; use 30° and/or 45° bends instead. The radius of the elbows should preferably be 1-1/2 times the diameter of the duct. All ductwork should be smooth inside with no projections from sheet metal screws or other obstructions, which will collect lint. When adding ducts, overlap the duct being connected. All ductwork joints must be taped to prevent moisture and lint from escaping into the building. Back draft dampers must be installed in all commonly ducted systems. Inspection doors should be installed at strategic points in the exhaust ductwork for periodic inspection and cleaning of lint from the ductwork.

IMPORTANT: It is recommended that exhaust or booster fans not be used in the exhaust ductwork system.

Exhaust back pressure measured by a manometer/magnehelic in the exhaust duct must be no less than 0 and must not exceed 0.6 in WC (1.48 mb).

NOTE: When the exhaust ductwork passes through a wall, ceiling, or roof made of combustible materials, the opening must be 2-inches (5.08 cm) larger than the duct (all the way around). The duct must be centered within this opening.

As per the National Fuel Gas Code, "Exhaust ducts for type 2 clothes dryers shall be constructed of sheet metal or other noncombustible material. Such ducts shall be equivalent in strength and corrosion resistance to ducts made of galvanized sheet steel not less than 26 gauge (0.0195-inches [0.50 mm]) thick."

The ductwork for this appliance must be suitable for the appliance category in accordance with national installation regulations of the country of destination.

Outside Ductwork Protection

To protect the outside end of the horizontal ductwork from the weather, a 90° elbow bent downward should be installed where the exhaust exits the building. If the ductwork travels vertically up through the roof, it should be protected from the weather by using a 180° turn to point the opening downward. In either case, allow at least twice the diameter of the duct between the duct opening and the nearest obstruction (refer to the diagram).

IMPORTANT: Do not use screens, louvers, or caps on the outside opening of the exhaust ductwork.

Single Dryer Venting

IMPORTANT: For extended ductwork runs, the cross-sectional area of the ductwork can only be increased to an extent. When the ductwork approaches the maximum limits as noted in this manual, a professional HVAC firm should be consulted for proper venting information.

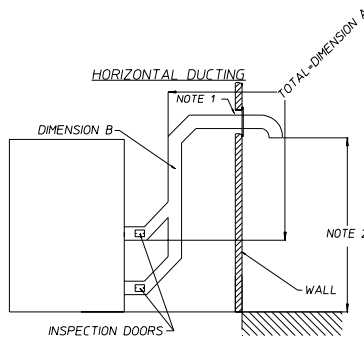

A = 12 feet (3.66 meters)
B = 8-inches (20.32 cm)

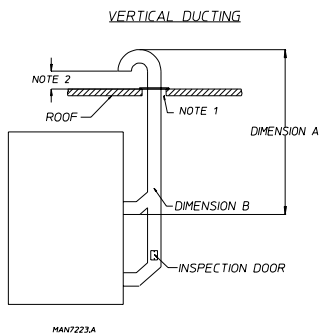

- NOTE 1** Opening from combustible materials must be 2-inches (5.08 cm) larger than the duct (all the way around). The duct must be centered within this opening.
- NOTE 2** Distance should be 2 times the diameter of the duct to the nearest obstruction.

The length of the ductwork from the dryer to the outside exhaust outlet, must not exceed 12 feet (3.66 meters). **The minimum diameter of this ductwork must be at least 8-inches (20.32 cm) even though the dryer exhaust duct connection is smaller.** Including tumbler/dryer elbow connections or elbows used for outside protection from the weather, no more than 4 90° elbows should be used in the exhaust duct run. If more than the equivalent of four 90° elbows are used, the cross-sectional area of the ductwork must be increased.

Multiple Dryer (Common) Venting

IMPORTANT: For extended ductwork runs, the cross-sectional area of the ductwork can only be increased to an extent. When the ductwork approaches the maximum limits as noted in this manual, a professional HVAC firm should be consulted for proper venting information.

If it is not feasible to provide separate exhaust ducts for each dryer, ducts from individual dryers may be channeled into a "common main duct." The individual ducts should enter the bottom or side of the main duct at an angle not more than 45° in the direction of airflow. The main duct should be tapered, with the diameter increasing before each individual duct is added. The minimum diameter of the individual ductwork must be at least 8-inches (20.32 cm).

IMPORTANT: No more than four dryers should be connected to one main common duct.

The illustration below shows the minimum cross-sectional area for multiple dryer round or square venting. These figures must be increased if the main duct run from the last dryer to where it exhausts to the outdoors is longer than 12 feet (3.66 meters) or has more than 1 elbow in it.

Multiple Dryer Venting with 6-Inch (15.24 cm) Diameter
440 cfm (12.46 cmm) Exhaust Connections at Common Duct

NUMBER OF DRYERS		4	3	2	1
MINIMUM CROSS-SECTIONAL AREA	SQ IN	164	120	80	54
	SQ CM	1058	774.2	516.1	348.4
MINIMUM ROUND DUCT DIAMETER	IN	14	12	10	8
	CM	35.56	30.48	25.4	20.32

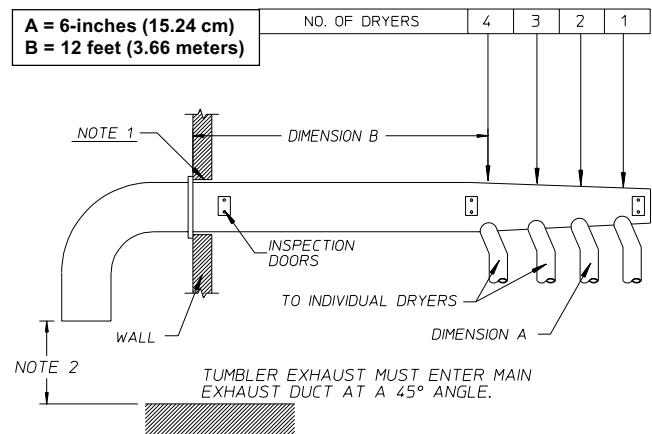

JCARRITA 04/21/04

MAN7212

- NOTE 1** Opening from combustible materials must be 2-inches (5.08 cm) larger than the duct (all the way around). The duct must be centered within this opening.
- NOTE 2** Distance should be 2 times the diameter of the duct to the nearest obstruction.

Electrical Information _____

Electrical Requirements

All electrical connections must be made by a properly licensed and competent electrician. This is to ensure that the electrical installation is adequate and conforms to local, state, and national regulations or codes of the country of destination. In the absence of such codes, all electrical connections, materials, and workmanship must conform to the applicable requirements of the National Electrical Code ANSI/NFPA NO. 70-LATEST EDITION or in Canada, the Canadian Electrical Codes Parts 1 & 2 CSA C22.1-1990 or LATEST EDITION.

IMPORTANT: Failure to comply with these codes or ordinances, and/or the requirements stipulated in this manual can result in personal injury or component failure.

NOTE: Component failure due to improper installation will void the warranty.

Each pocket should be connected to an independently protected branch circuit. The dryer must be connected with copper wire only. Do not use aluminum wire, which could cause a fire hazard. The copper conductor wire/cable must be of proper ampacity and insulation in accordance with electric codes for making all service connections.

NOTE: The use of aluminum wire will void the warranty.

An individual ground circuit must be provided to each pocket, do not daisy chain.

Component failure due to improper voltage application will void the warranty.

The manufacturer reserves the right to make changes in specifications at any time without notice or obligation.

IMPORTANT: A separate protected circuit must be provided to each pocket.

It is necessary to have a power disconnect for each pocket. These disconnects must be located within 9 meters of the unit and also be identified as being one of two power sources supplying a dryer.

The dryer must be connected to the electric supply shown on the data label. In the case of 208 VAC or 230/240 VAC, the supply voltage must match the electric service specifications of the data label exactly.

The wire size must be properly sized to handle the related current.

⚠ WARNING

208 VAC and 230/240 VAC are not the same. Any damage done to dryer components due to improper voltage connections will automatically void the warranty.

CAUTION: This unit has two power cords. Connect each plug to a receptacle that is connected to an individual branch circuit. Unplug both cords before moving or servicing this appliance.

The two power cord option is only available on the stack 120V gas models for the U.S. This option is not available on stack models for Canada. Canada models are to be hardwired. This hardwire option is also acceptable for the U.S.

⚠ WARNING (Gas Models Only)

Dryers built for use with a voltage between 200 and 230/240 must verify the input voltage during installation. If the nominal voltage is outside of the medium tolerances shown on the diagram below, adjust the autotransformers, located near the burner assemblies. To adjust the autotransformer wiring, place the red wire on the appropriate tap (HIGH, MED, LOW) of the autotransformer. For additional wiring details, refer to the electrical diagram located on the inside of the control panel.

TERM	LINE VOLTAGE	
	50 Hz	60 Hz
HIGH	260	283
	226	249
MED	239	260
	208	230
LOW	217	236
	189	208

Electrical Service Specifications Gas Models Only

ELECTRICAL SERVICE SPECIFICATIONS (PER POCKET)					
IMPORTANT: 208 VAC AND 230/240 VAC ARE NOT THE SAME. When ordering, specify exact voltage.					
NOTES:					
A. When fuses are used they must be dual element, time delay, current limiting, class RK1 or RK5 ONLY. Calculate/determine correct fuse value, by applying either local and/or National Electrical Codes to listed appliance amp draw data.					
B. Circuit breakers are thermal-magnetic (industrial) motor curve type ONLY. For others, calculate/verify correct breaker size according to appliance amp draw rating and type of breaker used.					
C. Circuit breakers for 3-phase (3ø) dryers must be 3-pole type.					
SERVICE VOLTAGE	PHASE	WIRE SERVICE	APPROX. AMP DRAW		CIRCUIT BREAKER
			60 Hz	50 Hz	
120	1ø	2	11.5	—	15
208	1ø	2	8.0	—	15
220	1ø	2	7.0	—	15
230	1ø	2	7.0	—	15
240	1ø	2	6.0	5.5	15

2/8/12

Electric Models Only

All electrically heated dryers must be connected to the electric service shown on the dryer's data label. The connecting wires must be properly sized to handle the rated current.

ELECTRICAL SERVICE SPECIFICATIONS (PER POCKET)						
IMPORTANT: 208 VAC AND 230/240 VAC ARE NOT THE SAME. When ordering, specify exact voltage.						
NOTES:						
A. When fuses are used they must be dual element, time delay, current limiting, class RK1 or RK5 ONLY. Calculate/determine correct fuse value, by applying either local and/or National Electrical Codes to listed appliance amp draw data.						
B. Circuit breakers are thermal-magnetic (industrial) motor curve type ONLY. For others, calculate/verify correct breaker size according to appliance amp draw rating and type of breaker used.						
C. Circuit breakers for 3-phase (3 ϕ) dryers must be 3-pole type.						
SERVICE VOLTAGE	PHASE	WIRE SERVICE	OVEN kW	APPROX. AMP DRAW		CIRCUIT BREAKER
				60 Hz	50 Hz	
208	1 ϕ	2	4.1	23.0	—	30
220	1 ϕ	2	4.5	24.0	—	30
230	1 ϕ	2	5.0	—	25.7	35
240	1 ϕ	2	5.4	26.0	—	35
380	3 ϕ	4*	4.5	—	10.8	15
400	3 ϕ	4*	5.0	—	11.2	15
416	3 ϕ	4*	5.4	—	11.5	15

2/8/12

Grounding

A ground (earth) connection must be provided and installed in accordance with local, state, and national regulations or codes of the country of destination. In the absence of these codes, grounding must conform to applicable requirements of the National Electrical Code ANSI/NFPA NO. 70-LATEST EDITION, or in Canada, the installation must conform to applicable Canada Standards: Canadian Electrical Codes Parts 1 & 2 CSA C22.1-1990 or LATEST EDITION. The ground connection may be to a proven earth ground at the location service panel.

For added personal safety, when possible, it is suggested that a separate ground wire (size per local codes) be connected from the ground connection of the dryer to a grounded cold water pipe. Do not ground to a gas pipe or hot water pipe. The grounded cold water pipe must have metal-to-metal connection all the way to the electrical ground. If there are any nonmetallic interruptions, such as, a meter, pump, plastic, rubber, or other insulating connectors, they must be jumped out with a wire (size per local codes) and securely clamped to bare metal at both ends.

IMPORTANT: For personal safety and proper operation, the dryer must be grounded.

Provisions are made for ground connection in each dryer at the electrical service connection area.

Electrical Connections

A wiring diagram is located behind the control panel for connection data.

If local codes permit, power to the dryer can be made by the use of a flexible UL listed power cord/pigtail (wire size must conform to rating of dryer), or the dryer can be hard wired directly to the service breaker panel. In both cases, a strain relief must be installed where the wiring enters the dryer.

For CE Models Only

The means for disconnection from the supply must be incorporated into wiring having a minimum contact separation of 3.0 mm in all poles.

Single-Phase (1 ϕ) Wiring Connections/Hookup

The electrical input connections are made into the rear service box located at the upper right area of the dryer. The ground connection is made to the copper lug, also provided in this box. To gain access, the service box cover must be removed.

IMPORTANT: A strain relief must be used where the input wiring enters the oven assembly.

Electrically Heated Models Only

The electrical input connections are made at the rear service box located at the right upper section of the dryer. The ground connection is made to a ground wire also provided in this area. To gain access, remove rear service cover.

The only electrical input connections to the dryer are the 3-phase (3 ϕ) power leads (L1, L2, L3, and sometimes neutral) and ground. Single-phase (1 ϕ) power for the control circuit and for any single-phase (1 ϕ) motors (if present) is done internally to the dryer by the factory at the oven contactor. No single-phase (1 ϕ) input connection is required on a 3-phase (3 ϕ) dryer.

The neutral will only be used on 4-wire service. This is typical for 380-416V, 50 Hz.

CAUTION: The dryer must be grounded. A ground lug has been provided for this purpose.

Input connection wiring must be sized properly to handle the dryer's current draw. This information is printed on the dryer's data label.

Gas Information

It is your responsibility to have all plumbing connections, materials, and workmanship conform to local and state regulations or codes of the country of destination. In the absence of such codes, all plumbing connections, materials, and workmanship must conform to the applicable local requirements. In the USA this is the National Fuel Gas Code ANSI Z223.1-LATEST EDITION, or in Canada, the Canadian Installation Codes CAN/CGA-B149.1-M91 (Natural Gas) or CAN/CGAB149.2-M91 (L.P. Gas) or LATEST EDITION.

In Australia, the fuel gas code is AS 5601 / AG 601, local authority, gas, electricity, and any other relevant statutory regulations.

It is important that gas pressure regulators meet applicable pressure requirements, and that gas meters be rated for the total amount of all the appliance Btu being supplied.

IMPORTANT: Failure to comply with these codes or ordinances, and/or the requirements stipulated in this manual, can result in personal injury and improper operation of the dryer.

For ease of service, the individual gas supply line of each dryer must have its own manual shutoff valve.

Failure to isolate or disconnect the dryer from supply as noted can cause irreparable damage to the gas valve, voiding the warranty.

The dryer and its individual shutoff valve must be disconnected from the gas supply piping system during any pressure testing of that system at test pressures in excess of 1/2 psig (3.5 kPa) for non-CE dryers or 50 mb for CE dryers.

NOTE: The dryer must be isolated from the gas supply piping system by closing its individual manual shutoff valve during any pressure test of the gas supply system at test pressures equal to or less than 1/2 psig (3.5 kPa) for non-CE dryers or 50 mb for CE dryers.

⚠ WARNING
Fire or explosion could result due to failure of isolating or disconnecting the gas supply as noted.

NOTE: Undersized gas piping will result in ignition problems, slow drying, increased use of energy, and can create a safety hazard.

The dryer must be connected to the type of heat/gas indicated on the data label and pressure must be confirmed. If this information does not agree with the type of gas available, do not operate the dryer. Contact the reseller who sold the dryer or contact the manufacturer.

The input ratings shown on the data label are for elevations up to 2,000 feet (610 meters), unless elevation requirements of over 2,000 feet (610 meters) were specified at the time the dryer order was placed with the factory. The adjustment or conversion of dryers in the field for elevations over 2,000 feet (610 meters) is made by changing each burner orifice. If this conversion is necessary, contact the reseller who sold the dryer or contact the manufacturer.

IMPORTANT: If connection to this appliance is made with a flexible hose, it must be suitable for the appliance category in accordance with national installation regulations of the country of destination, and if in doubt the installer must contact the supplier. The manufacturer of this appliance does not recommend the use of flexible gas supply line/hose. An external gas supply shutoff must be provided.

⚠ WARNING (CE Dryers Only)
This appliance must only be operated with the gas type indicated on the dryer's data plate. If the appliance is converted (gas type changed), a data plate amendment must be obtained from American Dryer Corporation for CE approved units.

Piping / Connections

The dryer is provided with two 3/8" N.P.T. inlet pipe connections (1 for each tumbler) at the rear of the dryer. If a separate feed is provided for each tumbler from the main supply line (header), then a 3/8" (9.52 mm) line connection is sufficient. However, if the top and bottom tumbler connections are connected together, the supply from the header must be increased to a minimum of 1/2-inch (12.7 mm). There should be a minimum 6-inch (15.24 cm) clearance between the back guard and the first bend in the gas piping for ease of servicing. It is recommended that a gas shutoff valve be provided to the gas supply line of each dryer for ease in servicing.

The size of the main gas supply line (header) will vary depending on the distance this line travels from the gas meter or, in the case of L.P. gas, the supply tank, other gas-operated appliances on the same line, etc. Specific information regarding supply line size should be determined by the gas supplier.

NOTE: Undersized gas supply piping can create a low or inconsistent pressure, which will result in erratic operation of the burner ignition system.

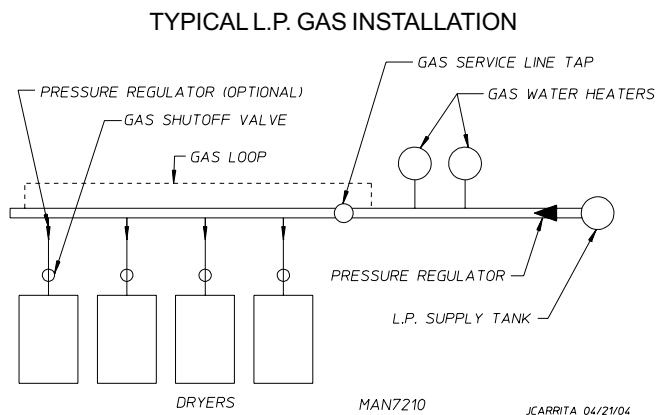
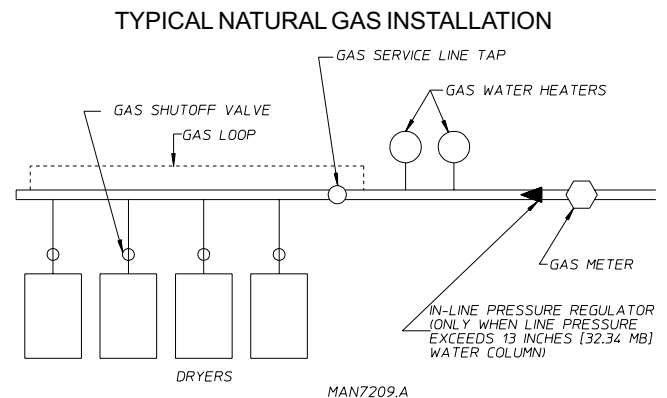

Consistent gas pressure is essential at all gas connections. It is recommended that a 3/4-inch (19.05 mm) pipe gas loop be installed in the supply line servicing a bank of dryers. An in-line pressure regulator must be installed in the gas supply line (header) if the (natural) gas pressure exceeds 13.0 in WC (32.34 mb) pressure.

A plugged tap, accessible for a pressure gauge connection, must be installed in the main gas supply line immediately upstream of the dryers.

Heat Input/Gas Consumption/Orifice (Injector) Data
(For Non-CE [European] and Non-AGA [Australia] Models Only)

Gas Specifications for Non-CE and Non-AGA Approved Dryers***								
Gas Type and Nominal Heating Value		Supply Pressure	**Gross Heat Input		Orifice Size		**Orifice (Injector) Quantity	Burner Pressure
	Btu/ft ³	in WC	Btu/hr	kW	DMS	mm		in WC
Natural	1,000	7.0 - 13.0	26,000	7.62	40	2.489	1	3.0
*Liquid Propane	2,500	11.0	26,000	7.62	53	1.511	1	10.5

Shaded areas are stated in metric equivalents

* Gas valve's internal regulator disabled.

** Information is per pocket/tumbler.

*** Consult factory for elevations over 2,000 feet (610 meters) for correct orifice size.

IMPORTANT: Pipe joint compounds that resist the action of natural, L.P., and butane gases must be used.

Test all connections for leaks by brushing on a soapy water solution (liquid detergent works well).

⚠ WARNING

Never test for leaks with a flame!!!

Converting from One Family of Gas to Another _____

⚠ WARNING (CE Dryers)

This appliance must only be operated with the gas type indicated on the dryer's data plate. If the appliance is converted (gas type changed), a data plate amendment must be obtained from American Dryer Corporation (dryer's serial number is required to purchase a conversion kit).

IMPORTANT: Any burner changes or conversions must be made by a qualified professional.

The dryers manufactured for Belgium, Luxemburg, Greece, Estonia, Slovak Republic, Iceland, Malta, Poland and Cyprus cannot be converted from one family of gas to another.

Conversion from Natural Gas to Propane or Butane Gas

The following conversion allows the dryer to be operated with either propane, butane, or LPG. The use of gas valve kit (ADC P/N 140414) disables the internal regulator of the gas valve. Therefore, the gas supply is unregulated and an external regulator must be provided at the source of the supply (example L.P. tank) or the gas supply line to the dryer. The L.P. kit supplied will depend on the country the dryer is installed in.

Parts Required for Conversion:

Description	ADC P/N	Qty
Unregulated Gas Conversion Kit***	140414	2*
OR		
Regulated L.P. Gas Conversion Kit****	140416	2*
Burner Orifice (Injector)	**	2*
L.P. Conversion Label	114515	2*

* This includes one for each pocket/tumbler.

** Refer to page 14 for orifice (injector) size.

*** Required for unregulated propane or butane only.

**** Required for regulated LPG or propane only.

Instructions

Disconnect electrical power to the dryer.

Close all shutoff valves (for both top and bottom tumbler) in dryer's gas supply line.

IMPORTANT: The following procedures must be performed on both top and bottom tumblers.

Open the panels located just below each loading door.

Locate the gas train and disconnect the union, three electrical plugs, and the gas train mounting screws from the burner. Carefully slide the gas train out of the gas train enclosure. (The carbon ignitor located at the far end of the gas train is very fragile.)

Remove two burner tube mounting screws and remove burner tube in order to gain access to the orifice.

Using a 3/8" wrench or socket, remove the existing orifice and replace it with an orifice from the kit.

IMPORTANT: Use extreme care when removing and replacing orifice (injector). This orifice (injector) is made of brass, which is easily damaged.

Reinstall the burner tube onto the burner base.

Use a flat screwdriver to remove the regulator vent cap.

- **For unregulated L.P. gas (most countries):** install blocking pin (ADC P/N 140414).
- **For regulated L.P. gas (some countries):** remove the white plastic regulator adjustment screw (under vent cap). Remove spring under screw and replace with spring from kit (ADC P/N 140416). Replace regulator adjustment screw.

Install the gas train back into the dryer gas train enclosure. Be sure the tab at the rear of the gas train engages into the mounting slot.

Connect the union and the three electrical plugs.

Repeat these steps for the other burner.

Affix L.P. Conversion Label (ADC P/N 114515) to the dryer's data label.

Complete L.P. Kit Conversion Confirmation Label (ADC P/N 114083) and affix this label as close as possible to the dryer's existing dryer rating (data) label/plate.

Non-CE Dryers

Affix L.P. Conversion Rating Label Addendum (ADC P/N 114090) as close as possible to the dryer's existing dryer rating (data) label/plate.

CE Dryers

Affix new data plate label that came with the conversion kit.

Open all shutoff valves, reconnect electrical power to the dryer, and test for leaks.

IMPORTANT: Never test for leaks with an open flame!!! Use a soapy water solution or product intended for that purpose.

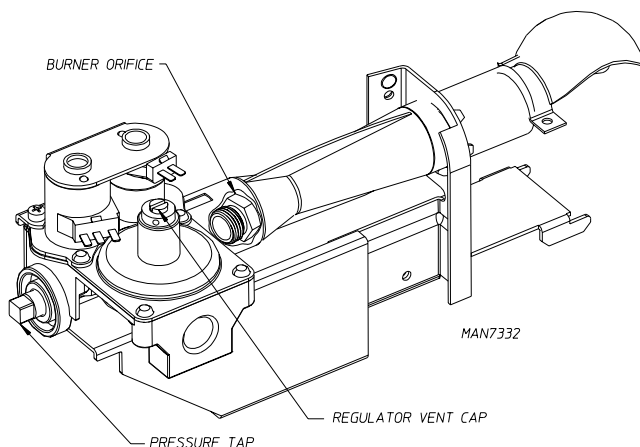

Unregulated Gas Valve

Regulate (govern) gas externally (refer to "Supply Pressure" in chart on page 14) to the correct gas pressure for the gas being used. Operate dryer through one complete cycle to ensure proper operation.

Regulated Gas Valve

Refer to "Gas Pressure Adjustment" on the following page to adjust the gas valve to the appropriate burner pressure listed on page 14. The supply pressure must also match what is listed on page 14 for the type of gas to be used.

IMPORTANT: Conversions done improperly can result in a fire or explosion!

Conversion from Propane or Butane Gas to Natural Gas

The following conversion allows the dryer to be operated with natural gas.

Parts Required for Conversion:

Description	ADC P/N	Qty
Vent Cap and Spring	140415	2*
Burner Orifice (Injector)	**	2*

* This includes one for each pocket (tumbler).

** Refer to page 14 for orifice (injector) size.

Instructions

Disconnect electrical power to the dryer.

Close all shutoff valves (for both top and bottom tumbler) in dryer's gas supply line.

IMPORTANT: The following procedures must be performed on both top and bottom tumblers.

Open the panels located just below each loading door.

Locate the gas train and disconnect the union, three electrical plugs, and the gas train mounting screws from the burner. Carefully slide the gas train out of the gas train enclosure. (The carbon ignitor located at the far end of the gas train is very fragile.)

Remove two burner tube mounting screws and remove burner tube in order to gain access to the orifice.

Using an 11/16" wrench or socket, remove the existing orifice and replace it with an orifice from the kit.

IMPORTANT: Use extreme care when removing and replacing orifice (injector). This orifice (injector) is made of brass, which is easily damaged.

Reinstall the burner tube onto the burner base.

Select from the following three options, the conversion to be performed:

- **Converting from unregulated L.P. to regulated natural gas:** use a flat screwdriver to remove the cap with blocking pin and install the regulator vent cap from the kit (ADC P/N 140415).
- **Converting from unregulated L.P. to unregulated natural gas:** no change to the regulator is required.
- **Converting from regulated L.P. to regulated natural gas:** remove the white plastic regulator adjustment screw (under vent cap). Remove spring under screw and replace with spring from kit (ADC P/N 140415). Replace regulator adjustment screw.

Install the gas train back into the dryer gas train enclosure. Be sure the tab at the rear of the gas train engages into the mounting slot.

Connect the union and the three electrical plugs.

Repeat these steps for the other burner.

Open all shutoff valves, reconnect electrical power to the dryer, and test for leaks.

Operate the dryer through one complete cycle to ensure proper operation.

With dryer operating, check the manifold (burner) pressure at the tap on the gas valve to ensure proper operating pressure (refer to chart on page 14).

Gas Pressure Adjustment

Disconnect electrical power to the dryer.

IMPORTANT: *The following procedures must be performed on both top and bottom tumblers.*

To adjust gas valve's internal regulator, remove the regulator vent cap, turn the screw clockwise to raise pressure and counterclockwise to lower pressure.

Gas (burner) pressures are measured with the burner in operation for all burner adjustment conditions. Therefore once the necessary adjustments have been made, the dryer must be operated in a heating cycle to verify that the pressure is correct. If it is not correct, you must discontinue the power to the unit and make further adjustments. Repeat these steps as many times as necessary to achieve the correct burner pressure. Once the adjustment of the valve is complete, the vent cap must be replaced and sealed with, for example, paint to prevent maladjustment by the user.

WARNING (CE Dryers)

This appliance must only be operated with the gas type indicated on the dryer's data plate. If the appliance is converted (gas type changed), a data plate amendment must be obtained from American Dryer Corporation.

Conversions done improperly can result in a fire or explosion!

Gas Pressure Testing

For proper operation, the gas pressure must be correct, consistent and maintained at the gas pressure rates shown on page 14. Provisions are made at the gas valve for taking gas pressure readings.

There are two types of devices used to measure gas pressure. They are the spring/mechanical type gauge and the manometer. The use of the spring/mechanical type gauge is not recommended because they are very easily damaged and are not always accurate. The preferred type of gauge is the manometer because it is a simple device to use and is highly accurate. A manometer is simply a glass or transparent plastic tube with a scale graduated in inches or millibars. When it is filled with water and pressure is applied, the water in the tube rises, showing the exact gas pressure.

Gas Pressure Test Procedure

Turn gas cock in gas supply line to "OFF" position.

60 Hz dryers: Install pressure tap and attach manometer (refer to the illustration on page 15).

Turn gas cock to "ON" position.

Start the dryer in Heat Mode and wait for ignition. Gas manifold pressure should be as shown on page 14.

If the gas pressure needs to be adjusted, refer to "Gas Pressure Adjustment" on this page.

Once test is complete, turn gas cock to "OFF" position. Remove manometer. Tighten screw inside the pressure tap or install plug.

Turn gas cock to "ON" position and check for leaks with soap solution with main burner "ON."

Preparation for Operation/Start-Up _____

The following items should be checked before attempting to operate the dryer:

- Read all "CAUTION," "WARNING," and "DIRECTION" labels attached to the dryer.
- Check incoming supply voltage to be sure that it is the same as indicated on the data label. In the case of 208 VAC or 230/240 VAC, the supply voltage must match the electric service exactly.
- GAS MODELS – Check to ensure that the dryer is connected to the type of heat/gas indicated on the dryer data label.
- GAS MODELS – Be sure that all gas shutoff valves are in the open position.
- Be sure all back panels (guards) and electric box covers are in place.
- Be sure the service doors are closed and securely in place.
- Be sure the lint door/drawer is securely in place.
- Rotate the tumbler (drum) by hand to be sure it moves freely.
- Check bolts, nuts, screws, terminals, and fittings for tightness and security.
- Check that the vent is connected to the dryer and is exhausted to the outdoors.

Preoperational Test _____

All dryers are thoroughly tested and inspected before leaving the factory. However, a preoperational test should be performed before the dryer is publicly used. It is possible that adjustments have changed in transit or due to marginal location (installation) conditions. Installer must instruct the user on how to correctly operate the dryer before leaving.

Turn on electric power to the dryer.

Refer to the Operating Instructions for starting your particular model dryer.

Gas Dryers

Open all shutoff valves.

When a gas dryer is first started (during initial start-up), it has a tendency not to ignite on the first ignition attempt. This is because the gas supply piping is filled with air, so it may take a few minutes for the air to be purged from the lines.

NOTE: *During the purging period, check to be sure that all gas shutoff valves are open.*

A gas pressure test should be taken at the gas valve pressure tap of each dryer to ensure that the water column pressure is correct and consistent.

NOTE: *Water column pressure requirements (measured at the pressure tap of the gas valve body) must be verified.*

IMPORTANT: *In most cases there is no regulator provided in an L.P. dryer. The water column pressure must be regulated at the source (L.P. tank), or an external regulator must be added to each dryer.*

Electrical Dryers

Check to ensure that electric oven/contacter assembly is activating.

Safety Related Circuits

Make a complete operational check of all safety related circuits:

- Door Switch(es)
- Hi-Limit Thermostats

Make a complete operational check of all operating controls.

Tumbler Coating

The tumbler is treated with a protective coating. We suggest dampening old garments or cloth material with a solution of water and nonflammable mild detergent and tumbling them in the tumbler to remove this coating.

Microprocessor Programs/Selections

Each microprocessor controller (computer) has been preprogrammed by the factory with the most commonly used parameter (program) selections. If computer program changes are required, refer to the computer programming manual, which was shipped with the dryer.

Preoperational Instructions _____

IMPORTANT: For more detailed information regarding the microprocessor controller (computer), refer to the microprocessor user's manual included with the dryer.

Coin Models

Microprocessor Controller (Computer)

When the microprocessor controller (computer) is in the ready state, the L.C.D. screen will display "FILL" and (xx.xx) Amount.

Insert coin(s). Once the correct "Amount to Start" has been inserted, the L.C.D. will display "PUSH".

Select temperature by pressing "HI," "LO," or "PERM PRESS." The cycle will start and the L.C.D. will display the Temperature Cycle selected and the remaining time.

The dryer will continue through the drying and cooling cycles, until the vended time has expired.

NOTE: To stop the dryer, open main door. Continuation of the cycle will resume only after the door has been closed and any one of the three temperature selections is pressed.

Non-Coin Models

Microprocessor Controller (Computer)

The L.E.D. display reads "FILL" (no cycle in progress).

Select temperature by pressing "HI," "LO," or "PERM PRESS".

The dryer will then start (i.e. blower, tumbler, and heat).

The L.E.D. display will display the temperature cycle selected and the remaining time.

NOTE: The dryer can be stopped at any time by opening the main door or the lint door.

When the programmed drying time has expired, the non-coin microprocessor controller (computer) will proceed into the Cool Down Cycle.

Shutdown Instructions _____

If the dryer is to be shutdown (taken out of service) for a period of time, the following must be performed:

Discontinue power to the dryer either at the external disconnect switch or the circuit breaker.

Discontinue the heat supply:

Gas Models – Discontinue the gas supply.

Shut off external gas supply shutoff valve.

Shut off internal gas supply shutoff valve located in the gas valve burner area.

Service / Parts Information _____

Service

Service must be performed by a qualified trained technician. If service is required, contact the reseller from whom the equipment was purchased. If the reseller cannot be contacted or is unknown, contact the Service Department for a reseller in your area.

NOTE: When contacting the Service Department, be sure to give them the correct model number and serial number so that your inquiry is handled in an expeditious manner.

Parts

Replacement parts should be purchased from the reseller from whom the equipment was purchased. If the reseller cannot be contacted or is unknown, contact the Parts Department for a reseller in your area. Parts may also be purchased directly from the factory by calling the Parts Department at +1 (508) 678-9000 or you may FAX in your order at +1 (508) 678-9447.

NOTE: When ordering replacement parts from the reseller or the manufacturer, be sure to give them the correct model number and serial number so that your parts order can be processed in an expeditious manner.

Warranty Information _____

Returning Warranty Cards

Before any dryer leaves the factory test area, a warranty card is placed on the inside of the main door glass. These warranty cards are intended to serve the customer where we record the individual installation date and warranty information to better serve you should you file a warranty claim.

If a warranty card did not come with your dryer, contact the Warranty Department or the Service Department at +1 (508) 678-9000.

IMPORTANT: A separate warranty card must be completed and returned for each individual dryer.

NOTE: Be sure to include the installation date when returning the warranty card(s).

Warranty

For a copy of the commercial warranty covering your particular dryer(s), contact the reseller from whom you purchased the equipment and request a dryer warranty form. If the reseller cannot be contacted or is unknown, warranty information can be obtained from the factory by contacting the Warranty Department at +1 (508) 678-9000.

NOTE: Whenever contacting the factory for warranty information, be sure to have the dryer's model number and serial number available so that your inquiry can be handled in an expeditious manner.

Returning Warranty Parts

All dryer or parts warranty claims or inquiries should be addressed to the Warranty Parts Department. To expedite processing, the following procedures must be followed:

No parts are to be returned without prior written authorization (R.M.A.) from the factory.

NOTE: An R.M.A. is valid for only 30 days from date of issue.

The R.M.A. issued by the factory, as well as any other correspondence pertaining to the returned part(s), must be included inside the package with the failed merchandise.

Each part must be tagged with the following information:

Model number and serial number of the dryer from which part was removed.

Nature of failure (be specific).

Date of dryer installation.

Date of part failure.

Specify whether the part(s) being returned is for a credit, replacement, or a refund.

NOTE: If a part is marked for a credit or a refund, the invoice number covering the purchase of the replacement part must be provided.

Warranty tags (Part No. 450064) are available at "no charge" from ADC upon request.

The company returning the part(s) must clearly note the complete company name and address on the outside of the package.

All returns must be properly packaged to ensure that they are not damaged in transit. Damage claims are the responsibility of the shipper.

IMPORTANT: No replacements, credits, or refunds will be issued for merchandise damaged in transit.

All returns should be shipped to the factory in such a manner that they are insured and a proof of delivery can be obtained by the sender.

Shipping charges are not the responsibility of ADC. All returns should be "prepaid" to the factory. Any "C.O.D." or "COLLECT" returns will not be accepted.

IMPORTANT: No replacements, credits, or refunds will be issued if the claim cannot be processed due to insufficient information. The party filing the claim will be notified in writing, either by "FAX" or "CERTIFIED MAIL – Return Receipt Requested," as to the information necessary to process claim. If a reply is not received by the Warranty Department within 30 days from the FAX/letter date, then no replacements, credits, or refunds will be issued, and the merchandise will be discarded.

Routine Maintenance

Cleaning

A program and/or schedule should be established for periodic inspection, cleaning, and removal of lint from various areas of the dryer, as well as throughout the ductwork system. The frequency of cleaning can best be determined from experience at each location. Maximum operating efficiency is dependent upon proper airflow. The accumulation of lint can restrict this airflow. If the guidelines in this section are met, the dryer will provide many years of efficient, trouble free, and most importantly, safe operation.

WARNING

Lint from most fabrics is highly combustible. The accumulation of lint can create a potential fire hazard. Keep dryer area clear and free from combustible materials, gasoline, and other flammable vapors and liquids.

NOTE: Suggested time intervals shown are for average usage, which is considered 6 to 8 operational (running) hours per day.

IMPORTANT: Dryer produces combustible lint and must be exhausted to the outdoors. Every 6 months, inspect the exhaust ducting and remove any lint buildup.

Suggested Cleaning Schedule

After Each Load

Clean the lint screen after each load. A clogged lint screen will cause poor dryer performance. The lint door is located just below the loading door of the dryer. Open the lint door, brush the lint off the lint screen, and remove the lint. Inspect lint screen and replace if torn.

Weekly

Clean lint accumulation from lint chamber, thermostat, and microprocessor temperature sensor area.

WARNING

To avoid the hazard of electrical shock, discontinue electrical supply to the dryer.

90 Days

Remove lint from gas valve burner area with a dusting brush or vacuum cleaner attachment.

Clean any lint accumulation in and around the motor(s) casing opening.

NOTE: To prevent damage, avoid cleaning and/or touching ignitor/ flame-probe assembly.

Every 6 Months

Inspect and remove lint accumulation in customer furnished exhaust ductwork system and from dryer's internal exhaust ducting.

NOTE: To remove the lint screen from the dryer, first remove the toe/control panel. Then remove two T-20 Torx® screws on the front of the lint screen frame and two hex nuts in the back. The lint screen must then be pulled out through two notches on both sides of the lint box opening.

The accumulation of lint in the exhaust ductwork can create a potential fire hazard.

Do not obstruct the flow of combustion and ventilation air. Check back draft dampers in the exhaust ductwork. Inspect and remove any lint accumulation, which can cause the damper to bind or stick.

A back draft damper that is sticking partially closed can result in slow drying and shutdown of heat circuit safety switches or thermostats.

If the hi-limit trips due to a high temperature occurrence, you must disconnect power before resetting. To reset, press and release the reset button, which is located on the top front, left corner of the lint box.

When cleaning the dryer cabinet(s), avoid using harsh abrasives. A product intended for the cleaning of appliances is recommended.

7 Days After Installation and Every 12 Months Thereafter

A competent professional should inspect bolts, nuts, screws, setscrews, grounding connections and nonpermanent gas connections (unions, shutoff valves, and orifices). Belts should be examined. Cracked or seriously frayed belts should be replaced. Complete an operational check of controls and valves. Complete an operational check of all safety devices (lint door/drawer switch, door switches, sail switch, and hi-limit thermostats).

Data Label Information

Standard Label

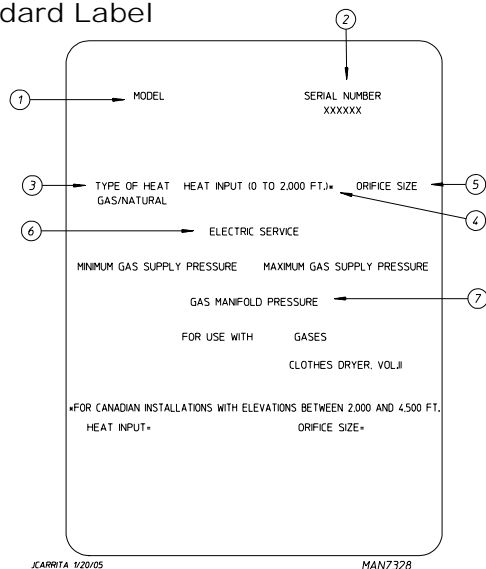

CE Label

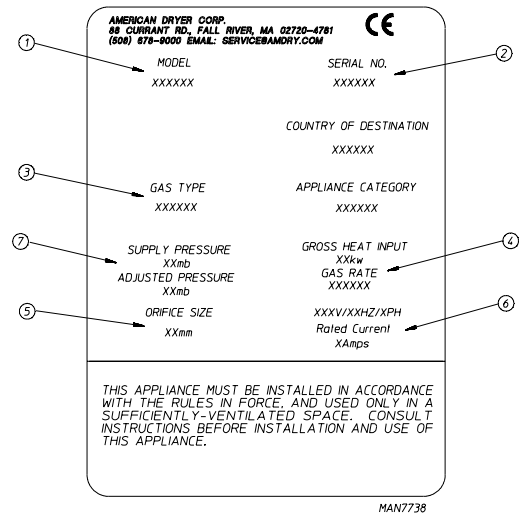

AGA Label

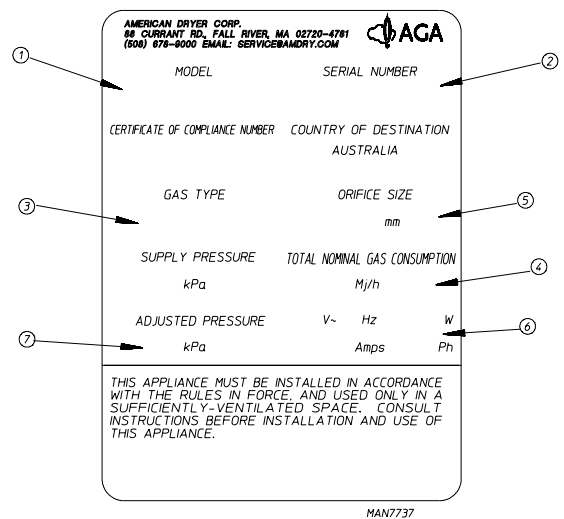

When contacting ADC, the information on the data label is required to ensure proper service/parts assistance. The data label is located at the upper left rear of the dryer behind the back guard.

1. Model Number – This describes the style of dryer and type of heat (gas, electric, or steam).
2. Serial Number – Allows the manufacturer to gather information on your particular dryer.
3. Type of Heat – This describes the type of heat for your particular dryer, gas (either natural gas or L.P. gas), electric, or steam.
4. Heat Input (For Gas Dryers) – This describes the heat input in British thermal units per hour (Btu/hr) or kilowatts (kW).
5. Orifice Size (For Gas Dryers) – Gives the number drill size used.
6. Electric Service – This describes the voltage and current rating for a particular model.
7. Gas Manifold Pressure (For Gas Dryers) – This describes the manifold pressure taken at the gas valve tap.

