

AD-24 "Domestic" **Installation/Operator's Manual**

WARNING: For your safety the information in this manual must be followed to minimize the risk of fire or explosion or to prevent property damage, personal injury or loss of life.

Do not store or use gasoline or other flammable vapors and liquids in the vicinity of this or any other appliance.

WHAT DO YOU DO IF YOU SMELL GAS

- * Do not try to light any appliance.
- * Do not touch any electrical switch; do not use any phone in your building.
- * Clear the room, building or area of all occupants.
- * Immediately call your gas supplier from a neighbor's phone. Follow the gas supplier's instructions.
- * If you cannot reach your gas supplier, call the fire department.

Installation and service must be performed by a qualified installer, service agency or the gas supplier.



For replacement parts, contact the distributor from which the dryer was purchased or

American Dryer Corporation

88 Currant Road

Fall River MA 02720-4781

Telephone: (508) 678-9010 / Fax: (508) 678-9447

E-mail: service@amdry.com

Retain This Manual In A Safe Place For Future Reference

American Dryer Corporation products embody advanced concepts in engineering, design, and safety. If this product is properly maintained, it will provide many years of safe, efficient, and trouble-free operation.

ONLY properly licensed technicians should service this equipment.

OBSERVE ALL SAFETY PRECAUTIONS displayed on the equipment or specified in the installation/operator's manual included with the dryer.

WARNING: UNDER NO CIRCUMSTANCES should the door switch or the heat circuit devices ever be disabled.

WARNING: The dryer *must never* be operated with any of the back guards, outer tops, or service panels removed. PERSONAL INJURY or FIRE COULD RESULT.

We have tried to make this manual as complete as possible and hope you will find it useful. ADC reserves the right to make changes from time to time, without notice or obligation, in prices, specifications, colors, and material, and to change or discontinue models.

Important

For your convenience, log the following information:

DATE OF PURCHASE _____ MODEL NO. AD-24 "Domestic"

DISTRIBUTORS NAME _____

Serial Number(s) _____

Replacement parts can be obtained from your distributor or the ADC factory. When ordering replacement parts from the factory, you can FAX your order to ADC at (508) 678-9447 or telephone your orders directly to the ADC Parts Department at (508) 678-9010. Please specify the dryer **model number** and **serial number** in addition to the **description** and **part number**, so that your order is processed accurately and promptly.

The illustrations on the following pages may not depict your particular dryer exactly. The illustrations are a composite of the various dryer models. Be sure to check the descriptions of the parts thoroughly before ordering.

INSTRUCTIONS TO BE FOLLOWED IN THE EVENT THE USER
SMELLS GAS MUST BE POSTED IN A PROMINENT LOCATION. THE
INSTRUCTIONS TO BE POSTED SHALL BE OBTAINED FROM THE
LOCAL GAS SUPPLIER.

IMPORTANT

YOU MUST DISCONNECT and LOCKOUT THE ELECTRIC SUPPLY and THE GAS SUPPLY or THE STEAM SUPPLY BEFORE ANY COVERS or GUARDS ARE REMOVED FROM THE MACHINE TO ALLOW ACCESS FOR CLEANING, ADJUSTING, INSTALLATION, or TESTING OF ANY EQUIPMENT per OSHA (Occupational Safety and Health Administration) STANDARDS.

CAUTION

LABEL ALL WIRES PRIOR TO DISCONNECTION WHEN SERVICING THE CONTROLS. WIRING ERRORS CAN CAUSE IMPROPER AND DANGEROUS OPERATION. VERIFY PROPER OPERATION AFTER SERVICING.

CAUTION

DRYER(S) SHOULD NEVER BE LEFT UNATTENDED WHILE IN OPERATION.

WARNING

CHILDREN SHOULD NOT BE ALLOWED TO PLAY ON OR IN THE DRYER(S).

CHILDREN SHOULD BE SUPERVISED IF NEAR DRYER(S) IN OPERATION.

WARNING

The dryer must never be operated with any of the back guards, outer tops, or service panels removed. PERSONAL INJURY or FIRE COULD RESULT.

FOR YOUR SAFETY

DO NOT STORE OR USE GASOLINE OR OTHER FLAMMABLE VAPORS AND LIQUIDS IN THE VICINITY OF THIS OR ANY OTHER APPLIANCE.

DO NOT DRY MOP HEADS IN THE DRYER.

DO NOT USE DRYER IN THE PRESENCE OF DRY CLEANING FUMES.

IMPORTANT

PLEASE OBSERVE ALL SAFETY PRECAUTIONS displayed on the equipment and/or specified in the installation/operator's manual included with the dryer.

Dryer(s) **must not** be installed or stored in an area where it will be exposed to water and/or weather.

The wiring diagram for the dryer is located in the front electrical control box area of the dryer. In addition, there is also one enclosed in the last page of this booklet.

Table of Contents

SECTION I

IMPORTANT INFORMATION	3
A. RECEIVING and HANDLING	3
B. SAFETY PRECAUTIONS	4

SECTION II

INSTALLATION PROCEDURES	6
A. UNPACKING/SETTING UP	6
B. LOCATION OF THE DRYER	6
C. DRYER ENCLOSURE REQUIREMENTS	7
D. FRESH AIR SUPPLY	8
E. EXHAUST REQUIREMENTS	9
F. ELECTRICAL INFORMATION	13
G. GAS INFORMATION	18
H. PREPARATION FOR OPERATION/START-UP	21
I. PREOPERATIONAL TESTS	21
J. PREOPERATIONAL INSTRUCTIONS	23
K. SHUT DOWN INSTRUCTIONS	23

SECTION III

SERVICE/PARTS INFORMATION	24
A. SERVICE	24
B. PARTS	24

SECTION IV

WARRANTY INFORMATION	25
A. RETURNING WARRANTY CARD(S)	25
B. WARRANTY	25
C. RETURNING WARRANTY PARTS	25

SECTION V

ROUTINE MAINTENANCE	27
A. CLEANING	27
B. ADJUSTMENTS	28
C. LUBRICATION	28

SECTION VI

ELECTRICAL SERVICE SPECIFICATIONS	29
--	-----------

SECTION VII

TROUBLESHOOTING	31
------------------------------	-----------

SECTION VIII
PROCEDURE FOR FUNCTIONAL CHECK OF
REPLACEMENT COMPONENTS 45

SECTION I

IMPORTANT INFORMATION

A. RECEIVING and HANDLING

The dryer is shipped in a protective stretch wrap cover with protective cardboard corners and top cover (or optional box) as a means of preventing damage in transit. Upon delivery, the dryer and/or packaging, and wooden skid **should be** visually inspected for shipping damage. If any damage whatsoever is noticed, inspect further before delivering carrier leaves.

Dryers damaged in shipment.

1. **ALL** dryers **should be** inspected upon receipt and before they are signed for.
2. If there is suspected damage or actual damage, the trucker's receipt **should be** so noted.
3. If the dryer is damaged beyond repair, it **should be** refused. Those dryers which were not damaged in a damaged shipment **should be** accepted, but the number received and the number refused **must be** noted on the receipt.
4. If you determine that the dryer was damaged after the trucker has left your location, you should call the delivering carrier's freight terminal immediately and file a claim. The freight company considers this concealed damage. This type of freight claim is very difficult to get paid and becomes extremely difficult when more than a day or two passes after the freight was delivered. It is your responsibility to file freight claims. Dryer/parts damaged in transit **cannot** be claimed under warranty.
5. Freight claims are the responsibility of the consignee, and **ALL** claims **must be** filed at the receiving end. **ADC** assumes no responsibility for freight claims or damages.
6. If you need assistance in handling the situation, please contact the **ADC** Traffic Manager at (508) 678-9000.

IMPORTANT: The tumbler section of the dryer <i>must be</i> transported and handled in an upright position at all times.
--

B. SAFETY PRECAUTIONS

WARNING: For your safety, the information in this manual *must be* followed to minimize the risk of fire or explosion or to prevent property damage, personal injury, or loss of life.

WARNING: The dryer must never be operated with any of the back guards, outer tops, or service panels removed. **PERSONAL INJURY or FIRE COULD RESULT.**

1. Keep dryer area clear and free from combustible materials, gasoline and other flammable vapors and liquids.
2. Purchaser/user should consult the local gas supplier for proper instructions to be followed in the event the user smells gas. The instructions **should be** posted in a prominent location.
3. WHAT TO DO IF YOU SMELL GAS..
 - a. **DO NOT** try to light any appliance.
 - b. **DO NOT** touch any electrical switch.
 - c. **DO NOT** use any phone in your building.
 - d. Clear the room, building, or area of **ALL** occupants.
 - e. Immediately call your gas supplier from a neighbor's phone. Follow the gas supplier's instructions.
 - f. If you **cannot** reach your gas supplier, call the fire department.
4. Installation and service **must be** performed by a qualified installer, service agency, or gas supplier.
5. Dryer(s) **must be** exhausted to the outdoors.
6. Although **ADC** produces a very versatile machine, there are some articles that, due to fabric composition or cleaning method, **should not** be dried in it.

WARNING: Dry only water-washed fabrics. **DO NOT** dry articles spotted or washed in dry cleaning solvents, a combustible detergent, or "all purpose" cleaner.
EXPLOSION COULD RESULT.

WARNING: **DO NOT** dry rags or articles coated or contaminated with gasoline, kerosene, oil, paint, or wax. **EXPLOSION COULD RESULT.**

WARNING: **DO NOT** dry mop heads. Contamination by wax or flammable solvents will create a fire hazard.

WARNING: **DO NOT** use heat for drying articles that contain plastic, foam, sponge rubber, or similarly textured rubber-like materials. Drying in a heated basket (tumbler) may damage plastics or rubber and also may be a fire hazard.

7. A program **should be** established for the inspection and cleaning of lint in the heating unit area, exhaust duct work, and inside the dryer. The frequency of inspection and cleaning can best be determined from experience at each location.

WARNING: The collection of lint in the burner area and exhaust duct work can create a potential fire hazard.

8. For personal safety, the dryer **must be** electrically grounded in accordance with local codes and/or the National Electric Code ANSI/NFPA NO. 70-LATEST EDITION.

NOTE: Failure to do so will VOID THE WARRANTY.

9. **UNDER NO CIRCUMSTANCES** should the dryer door switch, lint door switch, or heat safety circuit ever be disabled.

WARNING: PERSONAL INJURY or FIRE COULD RESULT.

10. This dryer is not to be used in the presence of dry cleaning solvents or fumes.

11. Remove articles from the dryer as soon as the drying cycle has been completed.

WARNING: Articles left in the dryer after the drying and cooling cycles have been completed can create a fire hazard.

12. **CAUTION:** Label **ALL** wires prior to disconnection when servicing controls. Wiring errors cause improper and dangerous operation. Verify proper operation after servicing.

13. **READ and FOLLOW ALL CAUTION and DIRECTION LABELS ATTACHED TO THE DRYER.**

WARNING: YOU MUST DISCONNECT and LOCKOUT THE ELECTRIC SUPPLY and THE GAS SUPPLY BEFORE ANY COVERS or GUARDS ARE REMOVED FROM THE MACHINE TO ALLOW ACCESS FOR CLEANING, ADJUSTING, INSTALLATION, or TESTING OF ANY EQUIPMENT per OSHA (Occupational Safety and Health Administration) STANDARDS.

SECTION II

INSTALLATION PROCEDURES

IMPORTANT: This dryer is **not to be** installed into a mobile home location.

Installation **should be** performed by competent technicians in accordance with local and state codes. In the absence of these codes, the installation **must conform** to applicable American National Standards:

National Fuel Gas Code ANSI.Z223.1-LATEST EDITION
and/or
National Electric Code ANSI/NFPA NO. 70-LATEST EDITION.

A. UNPACKING/SETTING UP

Remove protective shipping material (i.e., plastic wrap, and/or optional shipping box) from dryer.

The dryer can be moved to its final location while still attached to the skid or with the skid removed. To unskid the dryer, locate and remove the four (4) bolts securing the base of the dryer to the wooden skid. Two (2) are at the rear base (remove the back panel for access), and two (2) are located in the bottom of the lint chamber. To remove the two (2) bolts located in the lint chamber area, remove the lint door. Once the bolts are removed, slide the dryer off the skid.

With the skid removed, to make it easier to slide the dryer into its final position, slightly lower **ALL** four (4) leveling legs, so that the dryer will slide on the legs instead of the base frame. The dryer is equipped with four (4) leveling legs, one at each corner of the dryer base. Two (2) are located at the rear of the dryer base, and two (2) are located in the lint chamber.

To increase bearing life and improve efficiency, the dryer **should be** tilted slightly to the rear.

B. LOCATION OF THE DRYER

Before installing the dryer, be sure the location conforms to local codes and ordinances. In the absence of such codes or ordinances the location **must conform** with the National Fuel Gas Code ANSI.Z223.1-LATEST EDITION.

1. The dryer **must be** installed on a sound level floor capable of supporting its weight. It is recommended that carpeting be removed from the floor area that the dryer is to rest on.
2. The dryer **must not be** installed or stored in an area where it will be exposed to water and/or weather.
3. The dryer is for use in noncombustible locations.
4. Provisions for adequate air supply **must be** provided as noted in this manual (refer to **Fresh Air Supply** in **Section D**).

5. Clearance provisions **must be** made from non-combustible construction as noted in this manual (refer to **Dryer Enclosure Requirements** in Section C).
6. Provisions **must be** made for adequate clearances for servicing and for operation as noted in this manual (refer to **Dryer Enclosure Requirements** in Section C).
7. Dryer **must be** exhausted to the outdoors in an area where correct exhaust venting can be achieved as noted in this manual (refer to **Exhaust Requirements** in Section E).
8. Dryer **must be** located in an area where correct exhaust venting can be achieved as noted in this manual (refer to **Exhaust Requirements** in Section E).

IMPORTANT: Dryer *should be* located where a minimum amount of exhaust duct *will be* necessary.

C. DRYER ENCLOSURE REQUIREMENTS

Bulkheads and partitions **should be** made of noncombustible materials and **must be** located a minimum of twelve (12) inches (18-inches or more is recommended for ease of installation, maintenance, and service) above the dryer outer top, except along the front of the dryer which may be closed in if desired. The clearance between the bulkhead header and the dryer **must be** a minimum of four (4) inches and **must not** extend more than four (4) inches to the rear of the front.

NOTE: Allowances *must be* made for opening the control door.

IMPORTANT: If the dryer is installed in a closet type enclosure there must be no other fuel burning appliance installed in the same closet.

Dryers may be positioned side wall to side wall. However, allowances **must be** made for opening and closing of the control door and the lint door. It is suggested that the dryer be positioned about two (2) feet away from the nearest obstruction for ease of installation, maintenance, and service (to be measured from the back guard.) (Refer to the **illustration below** for details.)

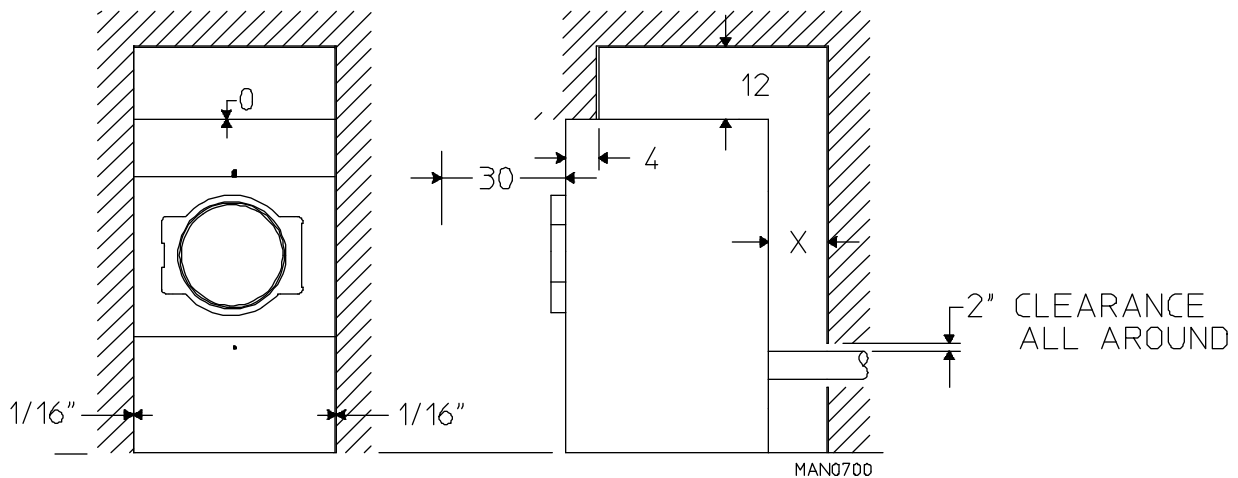

x = 12" minimum 24" suggested for ease of maintenance

NOTE: Air considerations are important for proper and efficient operation.

D. FRESH AIR SUPPLY

When the dryer is operating, it draws in room air, heats it, passes this air through the basket (tumbler), and exhausts it out of the building. Therefore, the room air **must be** continually replenished from the outdoors.

If the make-up air is inadequate, drying time and drying efficiency will be adversely affected. Ignition problems and sail switch "fluttering" problems may result, as well as premature motor failure from overheating.

Air supply (make-up air) **must be** given careful consideration to assure proper performance of each dryer. An unrestricted source of air is necessary for each dryer. An unrestricted air entrance from the outdoors (atmosphere) of a minimum of sixty (60) square inches is required for each dryer. If registers or louvers are installed over the openings, then the area **must be** increased.

IMPORTANT: Make-up air *SHOULD NOT* be located near duct work exhaust outlets. If the make-up air opening is too close to the exhaust outlet, lint and fumes may be drawn back into the dryer area through these openings.

Allowances **must be** made for remote or constricting passageways or where dryers are located at excessive altitudes or predominantly low-pressure areas.

IMPORTANT: Make-up air *must be* provided from a source free of dry cleaning fumes. Make-up air that is contaminated by dry cleaning fumes will result in irreparable damage to motors and other dryer components.

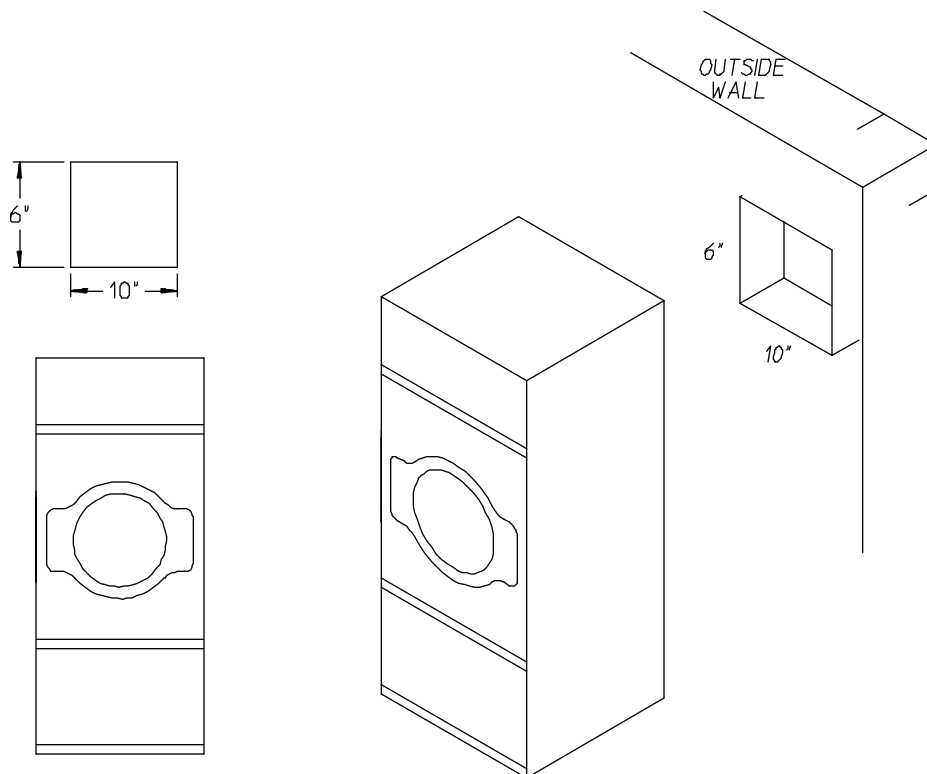

TYPICAL INSTALLATION SHOWING MAKE - UP AIR OPENING

MAN3597

NOTE: Component failure due to dry cleaning fumes will VOID THE WARRANTY.

E. EXHAUST REQUIREMENTS

Exhaust duct work **should be** designed and installed by a qualified professional. Improperly sized duct work will create excessive back pressure which results in slow drying, increased use of energy, overheating of the dryer, and shutdown of the burner by the airflow (sail) switches, burner hi-limits, or basket (tumbler) hi-heat thermostats. Refer to the illustrations on pages 10 and 11 for details.

CAUTION: IMPROPERLY SIZED OR INSTALLED EXHAUST DUCT WORK CAN CREATE A POTENTIAL FIRE HAZARD.

Where possible, it is desirable to provide a separate exhaust air duct for each dryer. The duct should go as directly as possible to the outside air. Avoid sharp 90° right-angle turns in ducting; use 30° or 45° angles instead. The radius of the elbows should preferably be 1-1/2 times the diameter of the duct. To protect the outside end of the duct from the weather, it may be bent downwards as indicated on **pages 10** and **page 11**. Leave at least twice the diameter of the duct as clearance between the duct opening and the nearest obstruction. If the exhaust duct goes through the roof, it may be protected from the weather by using a 180° turn to point the opening down. Allow at least twice the diameter of the duct as clearance from the nearest obstruction.

DO NOT use screens or caps on the outside opening of the exhaust duct. The ducting should be smooth inside with no projections from sheet metal screws or other obstructions which will collect lint. Provide inspection doors for periodic clean-out of lint from the duct.

Inadequate exhaust facilities may cause high temperature limit switches or airflow switches to shut off the dryers. **DO NOT** disable the switches, which are provided for your safety. Instead, investigate the exhaust ducting. Any obstruction or air friction due to numerous elbows/fittings in the ducting will slow the passage of air through the system with resulting inefficiency and potential fire hazard.

IMPORTANT: Exhaust back pressure measured by a manometer at each basket exhaust duct area **should not** exceed 0.3 inches of water column.

NOTE: Where the exhaust duct work passes through a wall, ceiling, or roof made of combustible materials, the opening **must be** 2 inches larger (all the way around) than the duct. The duct **must be** centered within this opening.

IMPORTANT: The dryer exhaust duct **must not be** connected to any gas vent, chimney, wall, ceiling, or concealing space of a building.

SINGLE DRYER VENTING

IMPORTANT: A minimum exhaust duct size of 8-inches *must be* used.

For an 8-inch horizontal run where a maximum of one (1) elbow is used (refer to Illus. below); the duct work from the dryer outlet **should not** exceed 25 feet.

HORIZONTAL SINGLE DRYER VENTING 8 INCH DUCTING

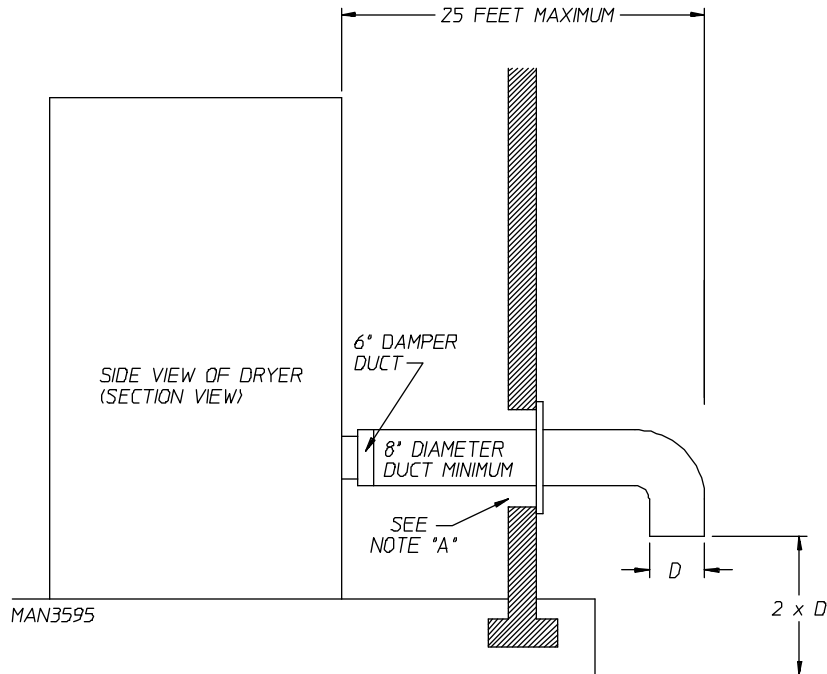

NOTE A: OPENING MUST BE TWO (2) INCHES LARGER THAN THE DUCT (ALL THE WAY AROUND) THE DUCT MUST BE CENTERED WITHIN THIS OPENING.

If the length of the duct run or quantity of elbows used exceeds the above noted specifications, the cross sectional area of the duct work **must be** increased in proportion to the number of elbows or duct run added.

IMPORTANT: For extended duct work runs, the cross section area of the duct work can only be increased to an extent. When the duct work approaches the maximum limits noted in this manual, a professional heating venting air conditioning (HVAC) firm *should be* consulted for proper venting information.

When single 9-inch venting is used, for a combination of vertical and horizontal runs, the duct work from the dryer to the outside outlet cannot exceed 35 feet (in total length). This calculation of 35 feet compensates or allows for the use of a maximum of three (3) elbows (which includes the outside outlet protection).

HORIZONTAL SINGLE DRYER VENTING 9 INCH DUCTING

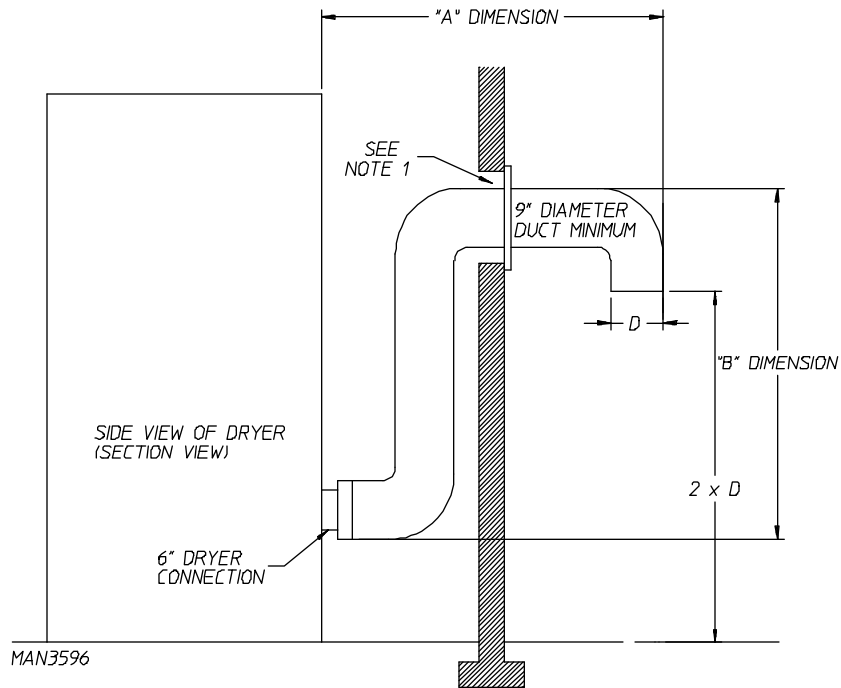

NOTE 1. OPENING MUST BE TWO (2) INCHES LARGER THAN THE DUCT (ALL THE WAY AROUND)
THE DUCT MUST BE CENTERED WITHIN THIS OPENING

NOTE 2. *A* DIMENSION + *B* DIMENSION SHOULD NOT EXCEED 35 FEET MAXIMUM

When single 10-inch vertical venting is used (refer to illustration below), the duct work from the dryer to the outside outlet cannot exceed 50 feet (in total length). This calculation of 50 feet compensates or allows for the use of a maximum of three (3) elbows including the 180° (turned downward) outside outlet.

VERTICAL SINGLE DRYER VENTING

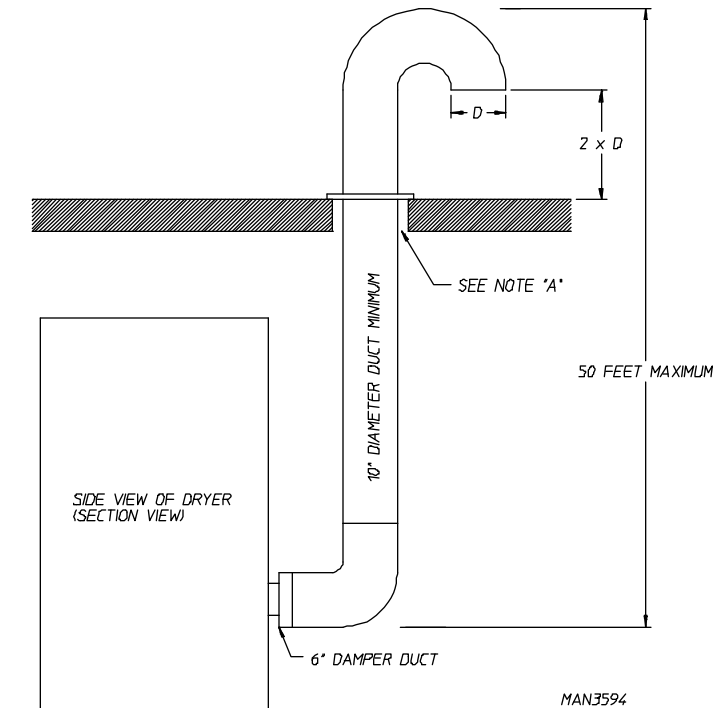

NOTE A: OPENING MUST BE TWO (2) INCHES LARGER THAN THE DUCT (ALL THE WAY AROUND)
THE DUCT MUST BE CENTERED WITHIN THIS OPENING

IMPORTANT: For extended duct work runs, the cross section area of the duct work can only be increased to an extent. When the duct work approaches the maximum limits as noted in this manual, a professional HVAC firm *should be* consulted for proper venting information.

IMPORTANT VENTING REMINDERS

1. Duct work size and installation **should be** done by a qualified professional.
2. The dryer **must be** exhausted to the outdoors.
3. The dryer exhaust **must not be** connected into any gas vent, chimney, wall, ceiling or concealing space of a building.
4. Duct work **should be** routed as short as possible to the outdoors with as few elbows as possible.
5. Avoid 90° turns ... use 30° or 45° turns instead.
6. The inside of the duct work **should be** as smooth as possible ... with no projections from sheet metal screws.
7. **ALL** ducts **should be** taped to prevent moisture and lint from escaping into the building.
8. Inspection/clean out doors **should be** installed throughout strategic points in the duct work for periodic inspection and cleaning.
9. Wherever the duct passes through combustible materials, the opening **must be** 2-inches larger (All The Way Around) than the duct. The duct **must be** centered within this opening.
10. The outside of the duct work **must be** protected from the weather. A 90° elbow **must be** used for a horizontal run and when vertically through a roof by using 180° turn to point the opening downward. Distance between the exhaust duct and the nearest obstruction (i.e., roof or ground) **must be** twice the diameter of the duct.
11. **DO NOT** use screens or caps on the outside opening of the exhaust duct work.
12. Exhaust back pressure, measured by a manometer at the dryer exhaust duct area, **must not** exceed 0.3 inches of water column.

F. ELECTRICAL INFORMATION

1. Electrical Requirements

It is your responsibility to have **ALL** electrical connections made by a properly licensed and competent electrician to assure that the electrical installation is adequate and conforms with local and state regulations or codes. In the absence of such codes, **ALL** electrical connections, materials, and workmanship **must conform** to the applicable requirements of the National Fuel Gas Code ANSI Z223.1-LATEST EDITION.

IMPORTANT: Failure to comply with these codes or ordinances, and/or the requirements stipulated in this manual, can result in PERSONAL INJURY or COMPONENT FAILURE.

NOTE: Component failure due to improper installation will VOID THE WARRANTY.

A separate circuit serving each dryer **must be** provided. The dryer **must be** connected to copper wire ONLY. **DO NOT** use aluminum wire which could cause a fire hazard.

NOTE: The use of aluminum wire will VOID THE WARRANTY.

2. Electrical Service Specifications (refer to Section VI for details)

a. Electric Service

1) *Gas Dryers ONLY*

IMPORTANT: The dryer **must be** connected to the electrical supply shown on the data label affixed to the dryer. In the case of 208 VAC or 240 VAC, the supply voltage **must match** the electric service specifications of the data label exactly. The wire size **must be** properly sized to handle the rated current.

WARNING: 208 VAC and 240 VAC **ARE NOT THE SAME**. Any damage done to dryer components due to improper voltage connections will automatically VOID THE WARRANTY.

NOTE: On gas dryers, to convert from 208 VAC to 240 VAC (or vice versa), the Direct Spark Ignition (DSI) transformer wiring **must be** changed.

2) *Electric Dryers ONLY*

ALL electrically heated dryers **must be** connected to the electric supply service shown on the dryer's data label which is affixed to the back side of the control (service) door. The connecting wires **must be** properly sized to handle the rated current.

NOTE: Component failure due to improper voltage application will VOID THE WARRANTY.

3. Grounding

A ground (earth) connection must be provided and installed in accordance with state and local codes. In the absence of these codes, grounding **must conform** to applicable requirements of the National Electric Code (ANSI/NFPA NO. 70-LATEST EDITION). The ground connection may be to a proven earth ground at the location service panel.

For added personal safety, when possible, it is suggested that a separate ground wire (no. 18 minimum) be connected from the ground connection of the dryer to a grounded cold water pipe. **DO NOT** ground to a gas pipe or hot water pipe. The grounded cold water pipe **must have** metal to metal connection all the way to electrical ground. If there are any nonmetallic interruptions, such as, a meter, pump, plastic, rubber, or other insulating connectors, they **must be** jumped with no. 4 copper wire and securely clamped to bare metal at both ends.

IMPORTANT: For personal safety and proper operation, the dryer **must be** grounded.

4. Electrical Connections

A wire diagram is located inside the control box for connection data.

a. GAS DRYERS ONLY - Single-Phase (1Ø) Hookup

The electrical connections on ALL single-phase (1Ø) dryers are made into the rear service box located at the upper left of the dryer.

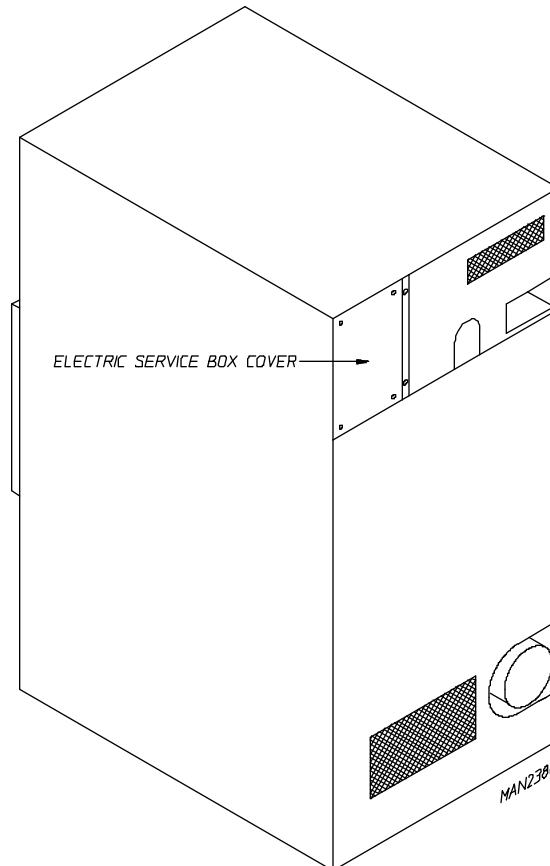

Actual electrical wire connections are made to the L1 and L2 terminals of the motor contactor located in the rear service box mentioned above. The ground connection is also made to the copper lug also provided in this box.

Single-Phase (1Ø) Electrical Connection Leads		
Black + Positive	White - Neutral	Green Ground
or L2		

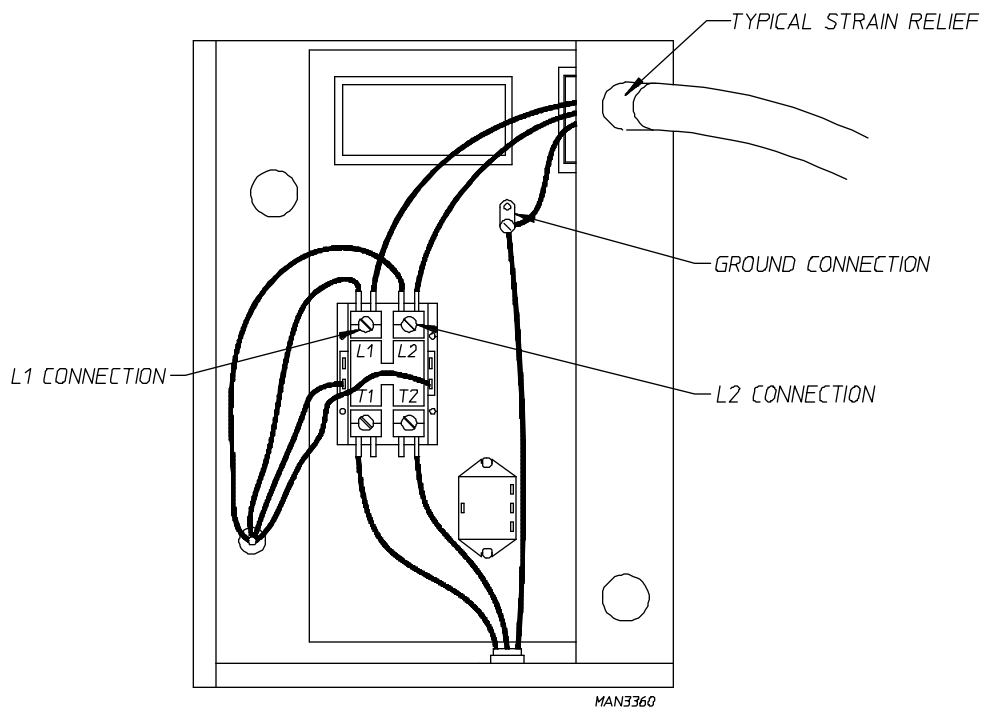

If local codes permit, power to the dryer can be made by the use of a flexible U.L. listed power cord/pigtail (wire size **must conform** to rating of dryer), or the dryer can be hard wired directly to the service breaker panel. In both cases, a strain relief **must be** installed where the wiring enters the dryer.

b. ELECTRIC DRYERS ONLY - Single-Phase (1Ø) Hookup

The electrical input connection is made into the electric oven contactor located at the upper rear of the dryer. Input connection wiring must be sized properly to handle the dryer's current draw. This information is printed on the dryer's data label.

NOTE: A separate circuit serving each dryer **must be** provided.

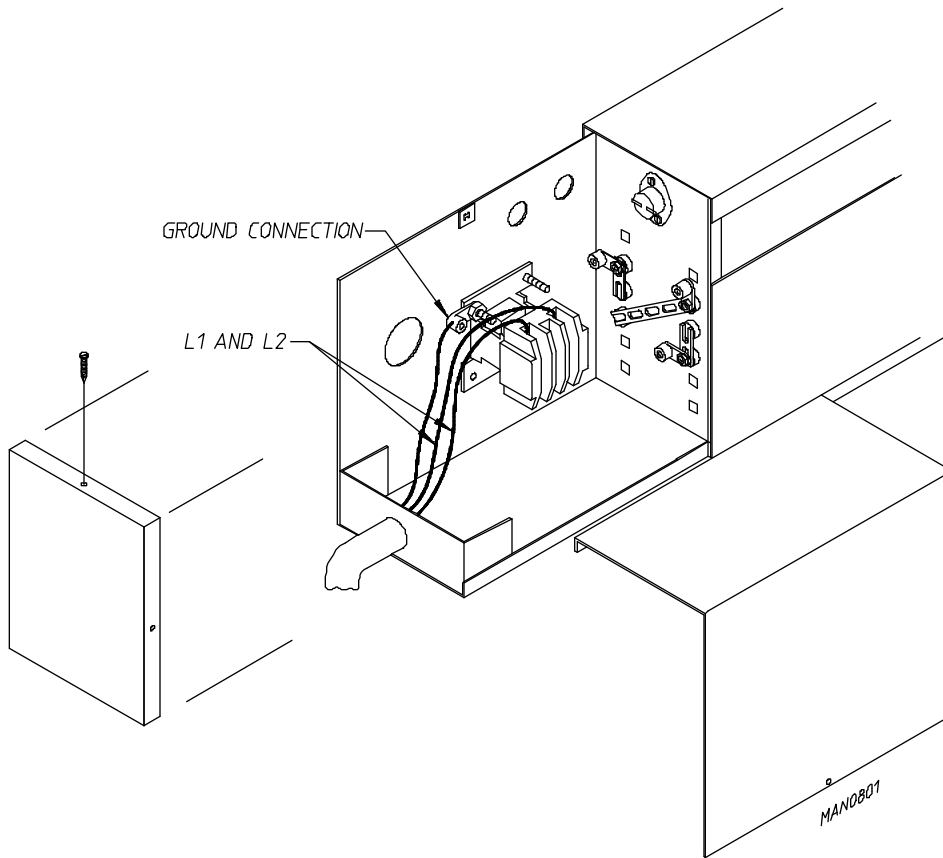

5. 3-Phase (3Ø) Wiring Connections

The only electrical input connections to the dryer are the 3-phase (3Ø) power leads (L1, L2, L3, and sometimes Neutral) and ground. Single phase (1Ø) power for the control circuit and for any single-phase (1Ø) motors (if present) is done internally to the dryer. No single-phase (1Ø) input connection is required on a 3-phase (3Ø) dryer.

a. GAS DRYERS ONLY - 3-Phase (3Ø) Hookup

For gas dryers manufactured for operation at 3-phase (3Ø), the electrical connections are made at the power distribution block located in the service box at the rear, upper left corner of the dryer. To gain access to the service box and contactor, the service box cover must be removed.

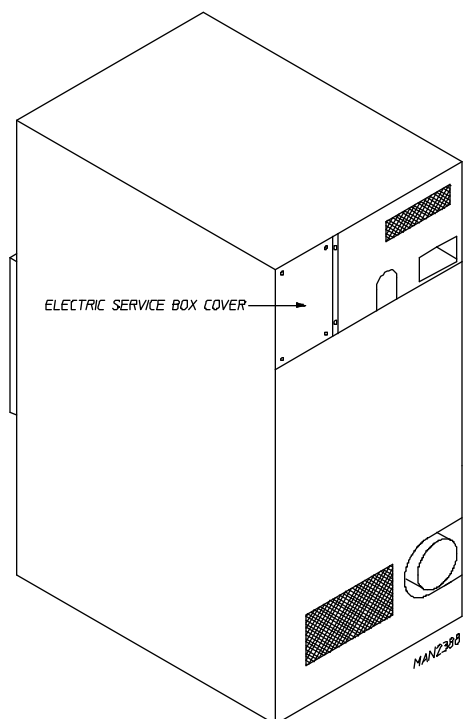

Providing local codes permit, power to the dryer can be made by the use of a flexible U.L. listed cord/pigtail (wire size **must conform** to the rating of the dryer), or the dryer can be hard wired directly to the service breaker. In **ALL** cases, a strain relief **should be** used both where the wiring enters the dryer and the service box.

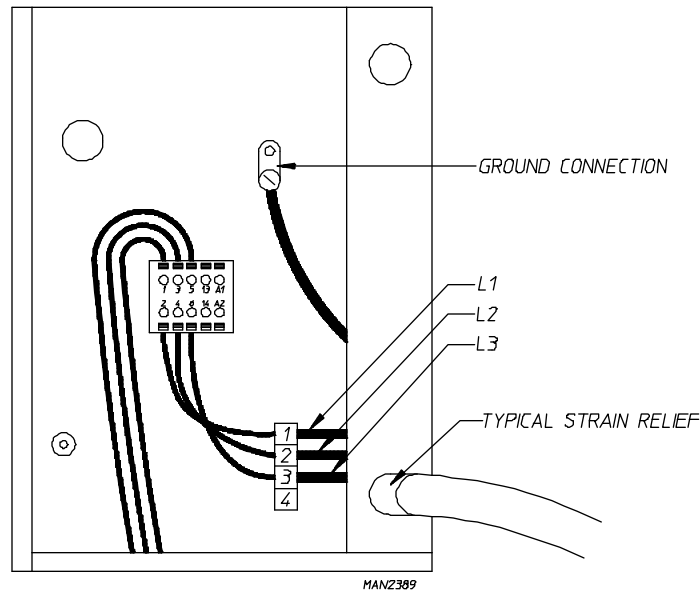

b. ELECTRIC DRYERS ONLY - 3-Phase (3Ø) Hookup

The electrical input connection is made into the electric oven contactor located at the upper rear of the dryer. Input connection wiring **must be** sized properly to handle the dryer's current draw. This information is printed on the dryer's data label.

CAUTION: The dryer **must be** grounded. A ground lug has been provided in the service box for this purpose.

NOTE: A separate circuit serving each dryer **must be** provided.

The only electrical connections to the dryer are the 3-phase (3Ø) leads (L1, L2, L3, and sometimes Neutral) and ground. Single-phase (1Ø) power for the control circuit is done by the factory at the contactor (relay), and no other wiring connections are necessary.

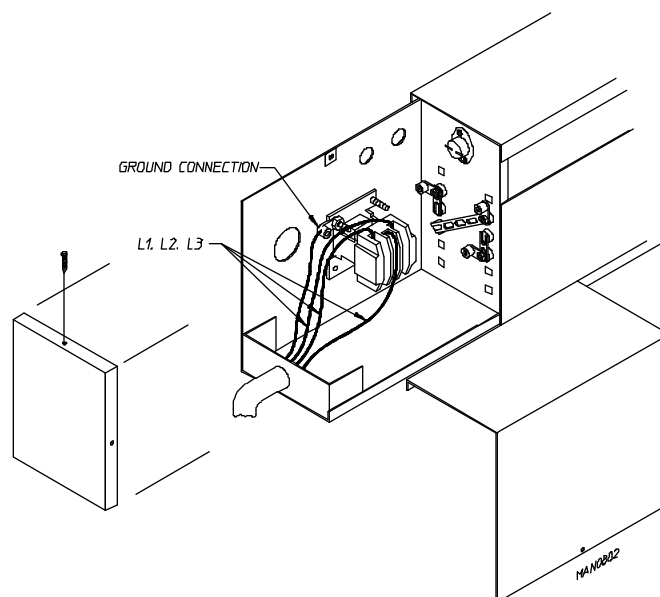

G. GAS INFORMATION

It is your responsibility to have **ALL** plumbing connections made by a qualified professional to assure that the gas plumbing installation is adequate and conforms with local and state regulations or codes. In the absence of such codes, **ALL** plumbing connections, materials, and workmanship **must conform** to the applicable requirements of the National Fuel Gas Code ANSI Z223.1-LATEST EDITION.

IMPORTANT: Failure to comply with these codes or ordinances, and/or the requirements stipulated in this manual, can result in PERSONAL INJURY and IMPROPER OPERATION of the dryer.

Each dryer must have its own manual shut off valve to provide isolation of the dryer from the gas supply.

The dryer and its individual shut-off valve **must be** disconnected from the gas supply piping system during any pressure testing of that system at test pressures in excess of 1/2 psig (3.5 kPa). The dryer **must be** isolated from the gas supply piping system by closing its individual manual shut-off valve during any pressure testing of the gas supply system at test pressures equal to or less than 1/2 psig (3.5 kPa).

IMPORTANT: Failure to isolate or disconnect the dryer from supply as noted can cause irreparable damage to the gas valve VOIDING THE WARRANTY.

WARNING: FIRE or EXPLOSION COULD RESULT.

1. Gas Supply

The gas dryer installation **must meet** the American National Standard...National Fuel Gas Code ANSI Z223.1-LATEST EDITION, as well as local codes and ordinances and **must be** done by a qualified professional.

NOTE: Undersized gas piping will result in ignition problems, slow drying, increased use of energy, and can create a safety hazard.

The dryer **must be** connected to the type of heat/gas indicated on the dryer data label. If this information does not agree with the type of gas available, **DO NOT operate the dryer**. Contact the distributor who sold the dryer or the ADC factory.

IMPORTANT: Any burner changes or conversions **must be** made by a qualified professional.

The input ratings shown on the dryer data label are for elevations up to 2,000 feet, unless elevation requirements of over 2,000 feet were specified at the time the dryer order was placed with the factory. The adjustment or conversion of dryers in the field for elevations over 2,000 feet are made by changing each burner orifice. If this conversion is necessary, contact the distributor who sold the dryer or contact the ADC factory.

2. Technical Gas Data

a. Natural Gas

The natural gas supply pressure to the dryer **must be** between 6 and 12 inches water column. If the pressure is too low, ignition failure and/or slow drying times may result. Excessively high supply pressure will result in erratic operation of the gas valve's internal pressure regulator. The pressure measured at the pressure tap on the body of the gas valve must be 3.5 inches water column.

b. Liquid Propane (L.P.) Gas

Dryers made for use with L.P. gas have the gas valve's internal pressure regulator blocked open so that the gas pressure **must be** regulated upstream of the dryer. The pressure measured at each gas valve pressure tap **must be** a consistent 11.0 inches water column. There is no regulator or regulation provided in an L.P. dryer. The water column pressure **must be** regulated at the source (L.P. tank) or an external regulator **must be** added to each dryer.

3. Piping/Connections

The dryer is provided with a 1/2" N.P.T. inlet pipe connection extending out the rear area of the dryer. For ease in servicing, the gas supply line of each dryer **must have** its own shut-off valve.

The size of the main gas supply line (header) will vary depending on the distance this line travels from the gas meter or, in the case of L.P. (liquid propane) gas, the supply tank, other gas-operated appliances on the same line, etc. Specific information regarding supply line size **should be** determined by the gas supplier.

NOTE: Undersized gas supply piping can create a low or inconsistent pressure which will result in erratic operation of the burner ignition system.

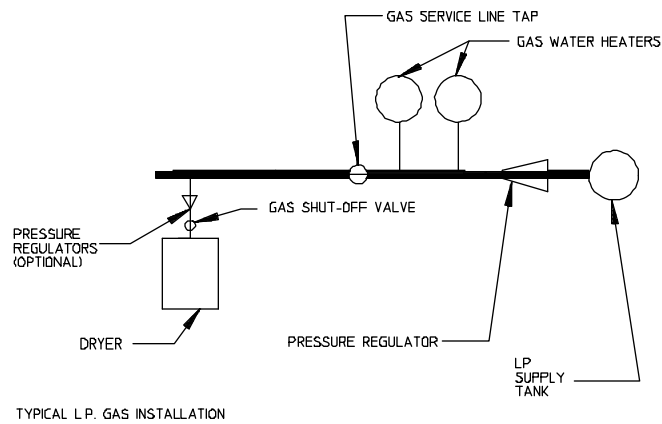
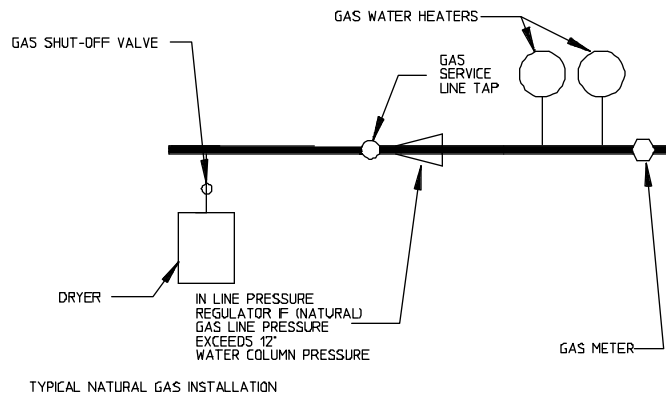

MAN3593

Consistent gas pressure is essential at **ALL** gas connections. An in-line pressure regulator **must be** installed in the gas supply line (header) if the (natural) gas pressure exceeds 12.0 inches of water column pressure.

NOTE: A water column test pressure of 3.5-inches for natural gas and 11.0-inches for L.P. (liquid propane) dryers is required at the gas valve pressure tap of each dryer for proper and safe operation.

A 1/8" N.P.T. plugged tap, accessible for a test gauge connection, **must be** installed in the main gas supply line immediately upstream of each dryer.

IMPORTANT: Pipe joint compounds that resist the action of natural gas and L.P. gas **must be** used.

IMPORTANT: Test **ALL** connections for leaks by brushing on a soapy water solution (liquid detergent works well).

WARNING: NEVER TEST FOR LEAKS WITH A FLAME!!!

ALL components/materials **must conform** to National Gas Code specifications. It is important that gas pressure regulators meet applicable pressure requirements and that gas meters be rated for the total amount of **ALL** the appliance BTU's being supplied.

H. PREPARATION FOR OPERATION/START-UP

The following items **should be** checked before attempting to operate the dryer:

1. Read **ALL** "**CAUTION**," "**WARNING**," and "**DIRECTION**" labels attached to the dryer.
2. Check incoming supply voltage to be sure that it is the same as indicated on the dryer data label affixed on the back of the dryer control (service) door.
3. **GAS MODELS** - check to assure that the dryer is connected to the type of heat/gas indicated on the dryer data label.
4. **GAS & ELECTRIC MODELS** - the sail switch damper assembly was installed and adjusted at the factory prior to shipping. However, each sail switch adjustment **must be** checked to assure that this important safety control is functioning.
5. Check bolts, nuts, screws, terminals, and fittings for tightness.
6. **GAS MODELS** - be sure that **ALL** gas shut-off valves are in the open position.
7. Be sure **ALL** back guard panels and service box covers have been replaced..
8. Check the lint door to assure that it is closed and secured in place.

IMPORTANT: If during installation the lint door safety chain was disconnected, it **must be** reconnected or personal injury may result.

9. Rotate the basket (tumbler) by hand to be sure it moves freely.

I. PREOPERATIONAL TESTS

ALL dryers are thoroughly tested and inspected before leaving the factory. However, a preoperational test **should be** performed before the dryer is publicly used. It is possible that adjustments have changed in transit or due to marginal location (installation) conditions.

1. Turn on electric power to the dryer.
2. Refer to the Operating Instructions for starting your particular model dryer.
3. *Gas Dryers*
 - a. When a gas dryer is first started (during initial start-up), it has a tendency not to ignite on the first ignition attempt. This is because the gas supply piping is filled with air, so it may take a few minutes for the air to be purged from the lines.

NOTE: During the purging period, check to be sure that **ALL** gas shut-off valves are open.

NOTE: Gas dryers are equipped with a Direct Spark Ignition (DSI) system which has internal diagnostics. If ignition is not established after the first attempt, the heat circuit in the DSI module will lock out until it is manually reset. To reset the DSI system, open and close the main door and restart the dryer.

- b. A gas pressure test **should be** taken at the gas valve pressure tap of each dryer to assure that the water column pressure is correct and consistent.

NOTE: Water column pressure requirements (measured at the pressure tap of the gas valve body):

Natural Gas 3.5 Inches Water Column
L.P. Gas 11.0 Inches Water Column

IMPORTANT: There is no regulator provided in an L.P. dryer. The water column pressure **must be** regulated at the source (L.P. tank), or an external regulator **must be** added to each dryer.

- 4. Make a complete operational check of **ALL** safety related circuits:

- a. Door Switch(es)
- b. Hi-Limit thermostats
- c. Cycling thermostats
- d. Sail switch (for Gas & Electric Models Only)

NOTE: The sail switch can be checked for proper operation by opening the lint door while the heating circuit (gas burner/electric oven) is active (on). The heating unit should shut off within a few seconds. If not, make necessary adjustments to sail switch.

- 5. Make a complete operational check of **ALL** operating controls.

NOTE: If computer program changes are required, refer to the computer programming section of the manual supplied with the dryer.

- 6. The dryer should be operated through one (1) complete cycle to assure that no further adjustments are necessary and that ALL components are functioning properly.

IMPORTANT: The dryer basket (tumbler) is treated with a protective coating. ADC suggests tumbling old clothes or material in the basket (tumbler), using a mild detergent to remove the protective coating.

- 7. Check the electric service phase sequence (3-phase (3Ø) models Only). While the dryer is operating, check to see if the blower wheel (impellor/fan) is rotating in the proper direction. Looking from the front, the blower wheel (impellor/fan) should spin in the clockwise direction. If it is, the phasing is correct. If the phasing is incorrect, reverse the two (2) leads at connections L1, L2, or L3 of the power supply to the dryer.

IMPORTANT: If the blower wheel (impellor/fan) is rotating in the wrong direction, this will not only drastically reduce drying efficiency, but it can also cause premature component failure.

J. PREOPERATIONAL INSTRUCTIONS

1. To start the dryer:

a. Microprocessor (computer) dryers

1. The L.E.D. display will read "FILL".
2. Press the "E" on the touchpad of the keyboard.
3. The L.E.D. display will quickly show "Ld30", "LC04", "F180".
The dryer will start, and the L.E.D. display will show "dr30".

b. Dual Timer Dryers

1. Turn drying timer knob for a time of 20 minutes.
2. Select "High Temp."
3. Push "Push To Start" Switch.
4. To stop dryer, open the main door.

K. SHUT DOWN INSTRUCTIONS

If the dryer is to be shut down (taken out of service) for a period of time, the following **must be** performed:

1. Discontinue power to the dryer either at the external disconnect switch or the circuit breaker.
2. Discontinue the gas supply (for GAS MODELS ONLY):
 - 1) **SHUT OFF** external gas supply shut-off valve.
 - 2) **SHUT OFF** internal gas supply shut-off valve located in the gas valve burner area.

SECTION III

SERVICE/PARTS INFORMATION

A. SERVICE

1. Service **must be** performed by a qualified trained technician, service agency, or gas supplier. If service is required, contact the distributor from whom the **ADC** equipment was purchased. If the distributor *cannot* be contacted or is unknown, contact the **ADC** Service Department for a distributor in your area.

NOTE: When contacting the **ADC** Service Department, be sure to give them the correct **model number** and **serial number** so that your inquiry is handled in an expeditious manner.

B. PARTS

1. Replacement parts **should be** purchased from the distributor from whom the **ADC** equipment was purchased. If the distributor *cannot* be contacted or is unknown, contact the **ADC** Parts Department for a distributor in your area. Parts may also be purchased directly from the factory by calling the **ADC** Parts Department at (508) 678-9010 or you may FAX in your order at (508) 678-9447.

NOTE: When ordering replacement parts from the **ADC** dealer or the **ADC** factory be sure to give them the correct **model number** and **serial number** so that your parts order can be processed in an expeditious manner.

SECTION IV

WARRANTY INFORMATION

A. RETURNING WARRANTY CARD(S)

1. Before any dryer leaves the **ADC** factory test area, a warranty card (**ADC** Part No. 112254) is placed on the back side of the main door glass. These warranty cards are intended to serve the customer where we record the individual installation date and warranty information to better serve you, if you file a warranty claim.
 - a. If a warranty card (**ADC** Part No. 112254) did not come with your dryer, contact the **ADC** Warranty Department or **ADC** Service Department at (508) 678-9000.

B. WARRANTY

For a copy of the **ADC** commercial warranty covering your particular dryer(s), contact the **ADC** distributor from whom you purchased the equipment and request dryer warranty form **ADC** Part No. 450199. If the distributor *cannot* be contacted or is unknown, warranty information can be obtained from the factory by contacting the **ADC** Warranty Department at (508) 678-9000.

NOTE: Whenever contacting the **ADC** factory for warranty or warranty information, be sure to have the dryer's **model number** and **serial number** available so that your inquiry can be handled in an expeditious manner.

C. RETURNING WARRANTY PARTS

ALL dryer or parts warranty claims or inquiries **should be** addressed to the **ADC** Warranty Parts Department. To expedite processing, the following procedures **must be** followed:

1. No parts are to be returned to **ADC** without prior written authorization ("Return Material Authorization") from the factory.

NOTE: An R.M.A. ("Return Material Authorization") is valid for only sixty (60) days from date of issue.

- a. The R.M.A. issued by the factory, as well as any other correspondence pertaining to the returned part(s), **must be** included inside the package with the failed merchandise.

2. Each part **must be** tagged with the following information:
 - a. **Model number** and **serial number** of the dryer from which part was removed.
 - b. Nature of failure (be specific).
 - c. Date of dryer installation.
 - d. Date of part failure.
 - e. Specify whether the part(s) being returned is for a replacement, a credit, or a refund.

NOTE: If a part is marked for a credit or a refund, the invoice number covering the purchase of the replacement part **must be** provided.

NOTE: Warranty tags (ADC Part No. 450064) are available at "no charge" from ADC upon request.

3. The company returning the part(s) must clearly note the complete company name and address on the outside of the package.
4. **ALL** returns **must be** properly packaged to insure that they are not damaged in transit. *Damage claims are the responsibility of the shipper.*

IMPORTANT: No replacements, credits or refunds will be issued for merchandise damaged in transit.

5. **ALL** returns **should be** shipped to the ADC factory in such a manner that they are insured and a proof of delivery can be obtained by the sender.
6. **Shipping charges are not the responsibility of ADC. ALL returns should be "prepaid" to the factory. Any "C.O.D." or "COLLECT" returns will not be accepted.**

IMPORTANT: No replacements, credits, or refunds will be issued if the claim *cannot* be processed due to insufficient information. The party filing the claim will be notified in writing, either by "FAX" or "CERTIFIED MAIL - Return Receipt Requested", as to the information necessary to process claim. If a reply is not received by the ADC Warranty Department within thirty (30) days from the FAX/letter date, then no replacement, credit, or refund will be issued, and the merchandise *will be* discarded.

SECTION V

ROUTINE MAINTENANCE

A. CLEANING

A program and/or schedule **should be** established for periodic inspection, cleaning, and removal of lint from various areas of the dryer, as well as throughout the duct work system. The frequency of cleaning can best be determined from experience at each location. Maximum operating efficiency is dependent upon proper air circulation. The accumulation of lint can restrict this air flow. If the guidelines in this section are met, an ADC dryer will provide many years of efficient, trouble-free, and - most importantly - safe operation.

WARNING: LINT FROM MOST FABRICS IS HIGHLY COMBUSTIBLE. THE ACCUMULATION OF LINT CAN CREATE A POTENTIAL FIRE HAZARD

WARNING: KEEP DRYER AREA CLEAR AND FREE FROM COMBUSTIBLE MATERIALS, GASOLINE, and OTHER FLAMMABLE VAPORS and LIQUIDS.

NOTE: Suggested time intervals shown are for average usage which is considered six (6) to eight (8) operational (running) hours per day.

SUGGESTED CLEANING SCHEDULE

EVERY THIRD or FOURTH LOAD

Clean the lint screen every third or fourth load. A clogged lint screen will cause poor dryer performance. The lint screen is located behind the lint door in the base of the dryer. Open the lint door, brush the lint off the lint screen, and remove the lint. Inspect lint screen and replace if torn.

NOTE: The frequency of cleaning the lint screen can best be determined from experience at each location.

WEEKLY

Clean lint accumulation from lint chamber, thermostat, and microprocessor temperature sensor (sensor bracket) area.

WARNING: TO AVOID THE HAZARD OF ELECTRICAL SHOCK, DISCONTINUE ELECTRICAL SUPPLY TO THE DRYER.

90 DAYS

1. Remove lint from around basket (tumbler), drive motors, and surrounding areas.
2. Remove lint from gas valve burner area with a dusting brush or vacuum cleaner attachment.
3. Clean any lint accumulation in and around both the blower and drive motor casing openings.

NOTE: To prevent damage, avoid cleaning and/or touching ignitor/flame-probe assembly.

EVERY 6 MONTHS

Inspect and remove lint accumulation in customer furnished exhaust duct work system and from dryers internal exhaust ducting.

NOTE: THE ACCUMULATION OF LINT IN THE EXHAUST DUCT WORK CAN CREATE A POTENTIAL FIRE HAZARD.

NOTE: DO NOT OBSTRUCT THE FLOW OF COMBUSTION and VENTILATION AIR. CHECK CUSTOMER FURNISHED BACK DRAFT DAMPERS IN THE EXHAUST DUCT WORK. INSPECT and REMOVE ANY LINT ACCUMULATION WHICH CAN CAUSE THE DAMPER TO BIND or STICK.

NOTE: A back draft damper that is sticking partially closed can result in slow drying and shutdown of heat circuit safety switches or thermostats.

NOTE: When cleaning the dryer cabinet(s), avoid using harsh abrasives. A product intended for the cleaning of appliances is recommended.

B. ADJUSTMENTS

7 DAYS AFTER INSTALLATION and EVERY 6 MONTHS THEREAFTER

Inspect bolts, nuts, screws, (bearing set screws), non-permanent gas connections (unions, shut-off valves, orifices, and grounding connections). Motor and drive belts **should be** examined. Cracked or seriously frayed belts **should be** replaced. Tighten loose V-belts when necessary. Complete operational check of controls and valves. Complete operational check of **ALL** safety devices (door switches, lint drawer switch, sail switch, burner and hi-limit thermostats).

C. LUBRICATION

The motor bearings, idler bearings, and tumbler bearings are permanently lubricated. NO LUBRICATION IS NECESSARY.

SECTION VI

ELECTRICAL SERVICE SPECIFICATIONS

AD-24 Gas Models

IMPORTANT: 208 VAC and 230/240 VAC ARE NOT THE SAME.
When ordering, specify exact voltage.

- NOTES:**
- A. Fuse ratings are dual element-time-delay-current limiting, class RK1 or RK5 ONLY.
 - B. Circuit breakers are thermal magnetic (industrial) type ONLY. For others, calculate/verify correct breaker size according to appliance amp draw rating and type of breaker used.
 - C. Circuit breakers for 3Ø dryers **must be** 3-pole type.

Service Voltage	Phase	Wire Service	Approx. Amp Draw	Fusing Dual Element Time Delay	Circuit Breaker
115	1Ø	2	8.6	12.0	20
208	1Ø	2	5.1	6.25	15
230/240	1Ø	2	4.8	6.0	15
208	3Ø	3	3.2	4.0	15
230/240	3Ø	3	2.9	3.5	15
460	3Ø	3/4	2.1	2.5	15

NOTE: Contact factory for electrical information not listed.

NOTE: ADC reserves the right to make changes in specifications at any time, without notice or obligation.

AD-24 Electric Models

IMPORTANT: 208 VAC and 230/240 VAC ARE NOT THE SAME.
When ordering, specify exact voltage.

- NOTES:**
- A. Fuse ratings are dual element-time-delay-current limiting, class RK1 or RK5 ONLY.
 - B. Circuit breakers are thermal magnetic (industrial) type ONLY. For others, calculate/verify correct breaker size according to appliance amp draw rating and type of breaker used.
 - C. Circuit breakers for 3Ø dryers **must be** 3-pole type.

Oven Size (Kw)	Service Voltage	Phase	Wire Service	Approx. Amp Draw	Circuit Breaker
18	208	1Ø	2	92.1	100
18	208	3Ø	3 or 4	55.3	60
18	240	1Ø	2	80.3	90
18	240	3Ø	3	48.6	60
20	208	1Ø	2	101.8	110
20	240	1Ø	2	88.6	100
24	208	3Ø	3 or 4	70.0	80
24	240	3Ø	3	61.5	70

NOTE: Contact factory for electrical information not listed.

NOTE: ADC reserves the right to make changes in specifications at any time, without notice or obligation.

SECTION VII

TROUBLESHOOTING

IMPORTANT: YOU MUST DISCONNECT and LOCKOUT THE ELECTRIC SUPPLY and THE GAS SUPPLY or THE STEAM SUPPLY BEFORE ANY COVERS or GUARDS ARE REMOVED FROM THE MACHINE TO ALLOW ACCESS FOR CLEANING, ADJUSTING, INSTALLATION, or TESTING OF ANY EQUIPMENT per OSHA (Occupational Safety and Health Administration) STANDARDS.

The information provided will help isolate the most probable component(s) associated with the difficulty described. The experienced technician realizes, however, that a loose connection or broken/ shorted wire may be at fault where electrical components are concerned ... and not necessarily the suspected component itself.

Electrical parts should always be checked for failure before being returned to the factory.

The information provided **should not be** misconstrued as a handbook for use by an untrained person making repairs.

IMPORTANT: When replacing blown fuses, the replacement **must be** of the exact rating as the fuse being replaced.

WARNING: ALL SERVICE and TROUBLESHOOTING **SHOULD BE PERFORMED BY A QUALIFIED PROFESSIONAL OR SERVICE AGENCY.**

WARNING: WHILE MAKING REPAIRS, OBSERVE ALL SAFETY PRECAUTIONS DISPLAYED ON THE DRYER or SPECIFIED IN THIS MANUAL.

MICROPROCESSOR (COMPUTER) MODELS

A. No display (microprocessor (computer) models ONLY) ...

1. Service panel fuse blown or tripped breaker.
2. Blown control circuit L1 or L2 1/2-amp (Slo Blo) fuse.
3. Failed microprocessor controller (computer).

B. Drive motor not operating (does not start) ...

1. Microprocessor (computer) motor indicator dot and relay output L.E.D. indicator are on ...
 - a. Failed drive motor contactor (relay).
 - b. Failed drive motor.

2. Microprocessor (computer) motor indicator dot and "door" L.E.D. indicator are on, but motor output L.E.D. indicator is off ...

a. Failed microprocessor controller (computer).

C. Drive motor operates okay for a few minutes, and then stops and will not restart ...

1. Motor is overheating and tripping out on internal overload protector ...

a. Motor air vents clogged with lint.

b. Low voltage to the motor.

c. Failed motor.

d. Basket (tumbler) is binding ... check for obstruction.

e. Failed idler bearings or tumbler bearings.

D. Microprocessor controller (computer) display reads "dSFL" continuously and the buzzer (tone) sounds every 30-seconds ...

1. Fault in microprocessor heat-sensing circuit ...

a. Blown "dSFL" 1/8-amp fuse on the microprocessor controller (computer).

b. Failed microprocessor temperature sensor.

c. Failed microprocessor controller (computer).

d. Broken wire or connection somewhere between the microprocessor controller (computer) and microprocessor temperature sensor.

E. Microprocessor controller (computer) display reads "door" and microprocessor controller (computer) "door" L.E.D. indicator is off ...

1. Fault (open circuit) in main door or applicable lint drawer/door switch circuit ...

a. Lint drawer/door not closed all the way.

b. Lint drawer/door switch out of proper adjustment.

c. Failed lint drawer/door switch.

d. Failed door switch.

e. Broken connection/wire in main door or lint drawer/door circuit.

2. Failed 24 VAC step down transformer or fault in wiring.

F. Microprocessor controller (computer) L.E.D. display reads "door" and microprocessor controller (computer) "door" L.E.D. indicator is on ...

1. Failed microprocessor controller (computer).

G. Microprocessor controller (computer) will not accept any keyboard (touchpad) entries, i.e., display reads "FILL" and when keyboard entries are selected, the display continues to read "FILL" . ..

1. Failed keyboard label (touchpad) assembly.
2. Failed microprocessor controller (computer).

H. Microprocessor controller (computer) will only accept certain keyboard (touchpad) entries ...

1. Failed keyboard label (touchpad) assembly.

I. Microprocessor controller (computer) locks up and display reads erroneous message(s) or only partial segments ...

1. Transient power voltage (spikes) ... disconnect power to dryer, wait one (1) minute and reestablish power to dryer ... if problem is still evident ...
 - a. Failed microprocessor controller (computer).
 - b. Failed keyboard label (touchpad) assembly.

J. Dryer stops during a cycle, microprocessor controller (computer) buzzer (tone) sounds for 5-seconds, and then L.E.D. display reads "dSFL", for approximately 30-seconds, and then returns to "FILL" ...

1. Loose connection somewhere between the microprocessor controller (computer) and the microprocessor temperature sensor.
2. Loose "dSFL" 1/8-amp fuse on the microprocessor controller (computer).

K. Dryer stops during a cycle, microprocessor controller (computer) buzzer (tone) sounds for 5 seconds, and then the L.E.D. display returns to "FILL" ...

1. Loose connection somewhere in the main power circuit to the microprocessor controller (computer).

L. Microprocessor controller (computer) L.E.D. display reads "SEFL" ...

1. Rotational sensor circuit (option) failure ... fault somewhere in basket (tumbler) rotation or circuit ...
 - a. Basket (tumbler) not rotating ...
 - 1) Broken or loose V-belts.
 - 2) Failure in drive motor circuit ... refer to ... Item B and Item C.
 - b. Failed rotational sensor.
 - c. Broken wire or connection between sensor and microprocessor controller (computer).

2. Microprocessor controller (computer) program (Key 2) is set incorrectly in the active mode ("SEn") where the dryer is not equipped with the **OPTIONAL** rotational sensor ... program **should be** set as "nSEN."

M. Microprocessor controller (computer) L.E.D. display reads "Hot" ...

1. Possible overheating condition ... microprocessor controller (computer) has sensed a temperature which has exceeded 220°F.

"Hot" display will not clear until temperature sensed has dropped to 220°F or lower and the microprocessor controller (computer) is manually reset by pressing the "CLEAR/STOP" key.

N. Heating unit is not operating (no heat) ... no voltage at heating unit (i.e., Gas Models - DSI module, Electric Model - electric oven contactor) when dryer is first started and both the heat indicator dot and the "HEAT" output L.E.D. are on ...

GAS MODELS

1. Fault in sail switch circuit ...
 - a. Sail switch is out of adjustment or has failed.
 - b. Sail switch damper is not closing or is fluttering ...
 - 1) Lint screen is dirty.
 - 2) Restriction in exhaust.
 - 3) No exhaust air flow ...
 - a) Failed impellor (blower/fan).
 - b) Fault in impellor (blower/fan) motor circuit.
2. Failed burner hi-limit switch.
3. Failed lint chamber sensor bracket basket (tumbler) hi-limit switch.

ELECTRIC MODELS

1. Fault in sail switch circuit ...
 - a. Sail switch is out of adjustment or has failed.
 - b. Sail switch damper is not closing or is fluttering ...
 - 1) Lint screen is dirty.
 - 2) Restriction in exhaust.
 - 3) No exhaust air flow ...

- a) Failed impellor (blower/fan).
 - b) Fault in impellor (blower/fan) motor circuit.
2. Failed oven hi-limit switch.
 3. Failed lint chamber sensor bracket basket (tumbler) hi-limit switch.
- O. Heating unit is not operating (no heat) ... no voltage at heating unit (i.e., Gas Model -DSI module, Electric Model - electric oven contactor) when dryer is first started and the microprocessor controller (computer) heat indicator dot is on but the "HEAT" relay output L.E.D. is not on ...**
1. Failed microprocessor controller (computer).
- P. No heat ... voltage is confirmed at heating unit (i.e., Gas Models - DSI module, Electric Model - electric oven contactor) ...**

GAS MODELS

1. Fault in Direct Spark Ignition (DSI) system ...
 - a. Ignitor sparks but no ignition and Direct Spark Ignition (DSI) module locks out (RED L.E.D. indicator light stays on) ...
 - 1) Ignitor probe assembly is out of adjustment or has failed.
 - 2) Severe air turbulence.
 - 3) Failed Direct Spark Ignition (DSI) module.
 - 4) Failed gas valve.
 - b. Ignitor sparks, burner lights but goes off right away ...
 - 1) DSI ignitor flame probe is out of adjustment or has failed.
 - 2) Sail switch is fluttering ...
 - a) Lint drawer screen is dirty.
 - b) Restriction in exhaust duct work.
 - c. Ignitor does not spark and Direct Spark Ignition (DSI) module locks out (RED L.E.D. indicator light stays on) ...
 - 1) Fault in high voltage (HV) wire ... break or loose connection.
 - 2) Failed ignitor probe assembly.
 - 3) Failed Direct Spark Ignition (DSI) module.

ELECTRIC MODELS

1. Failed oven contactor/coil.
2. Failed electric heating element(s).

Q. Dryer is taking too long to dry ...

1. Exhaust duct work run too long or is undersized ... back pressure cannot exceed .3 inches water column.
2. Restriction in exhaust ...
 - a. Dryer back draft damper is sticking partially closed.
 - b. Restriction/obstruction in duct work ...
 - 1) Check duct work from dryer all the way to the outdoors.
3. Insufficient make-up air.
4. Impellor (blower/fan) is rotating in the wrong direction (**3-phase (3Ø) Models ONLY**).
5. Lint drawer screen is dirty or is not being cleaned often enough.
6. Inadequate air flow ...
 - a. Impellor (blower/fan) failure.

7. Gas Models

- a. Low and/or inconsistent gas pressure ...

Natural Gas pressure must be between 3.5 inches and 4.0 inches of water column.

Liquid propane (L.P.) pressure must be between 10.5 inches and 11.0 inches of water column.
- b. Poor air/gas mixture (too much gas or not enough air) at burner ... yellow or poor flame pattern ...
 - 1) Not enough make-up air.
 - 2) Restriction in exhaust.
 - 3) Gas pressure too high.
 - 4) Impellor (blower/fan) rotating in the wrong direction.
 - 5) Burner orifice size (D.M.S.) too large for application (i.e., high elevation).

- c. Sail switch is fluttering ...
 - 1) Restriction in exhaust ...
 - a) Lint screen is dirty or is not being cleaned often enough.
- d. Failed burner hi-limit switch ... opens at incorrect temperature.
- e. Gas supply may have low heating value.

8. Electric Models

- a. Not enough make-up air.
- b. Restriction in exhaust.
- c. Lint screen is dirty or is not being cleaned often enough.
- d. Impellor (blower/fan) is rotating in the wrong direction (**3-phase [3Ø] Models ONLY**).
- e. Failed electric element(s).
- f. Sail switch is fluttering ...
 - 1) Restriction in exhaust.
 - 2) Sail switch not adjusted properly.

R. At the completion of the "AUtO" drying/cooling cycle ... load is coming out over dried ...

- 1. Percentage of dryness (dryness level) of cycle selected is too high.
- 2. "A" and "B" factors not set correctly or "B" factor has to be adjusted for adverse location conditions.

S. At the completion of the "AUtO" drying/cooling cycle ... load is coming out damp ...

- 1. Percentage of dryness (dryness level) of cycle selected is too low.
- 2. "A" and "B" factors not set correctly or "B" factor has to be adjusted for adverse location conditions.

T. Main burners are burning with a yellow flame (*for Gas Models ONLY*) ...

- 1. Poor air/gas mixture (too much gas or not enough air at burner) ...
 - a. Not enough make-up air.
 - b. Restriction in exhaust.
 - c. Gas pressure too high.
 - d. Impellor/blower/fan (**3-phase [3Ø] Models ONLY**) rotating in the wrong direction.
 - e. Burner orifice size (D.M.S.) too large for application (i.e., high elevation).

U. Condensation on main door glass ...

1. Too long, undersized, or improperly installed duct work.
2. Back draft damper is sticking in the partially closed position.

V. Dryer or scraping noise at basket (tumbler) area ...

1. Check for obstruction caught in basket (tumbler)/wrapper area.
2. Basket (tumbler) is out of proper alignment.
 - a. Check both vertical alignment and lateral alignment.
 - b. Check gap between front panel and the basket (tumbler) ... bearing set screws may have come loose, and basket (tumbler) walked forward or backward.

W. Excessive noise and/or vibration ...

1. Dryer is not leveled properly.
2. Impellor (blower/fan) out of balance ...
 - a. Excessive lint build up on impellor (blower/fan).
 - b. Failed impellor (blower/fan).
3. Loose basket (tumbler) tie rod.
4. Failed basket (tumbler) support.
5. Loose motor mount.
6. Failed idler bearings or basket (tumbler) bearings.
7. V-belts too tight or too loose.
8. Tumbler bearing set screws are loose.
9. Failed motor bearings.

TIMER MODELS

A. Dryer will not start ... drive motor is not operating (indicator light is off) ...

1. Service panel fuse blown or tripped breaker.
2. Dryer control circuit L1 or L2 1/2-amp fuse is blown.
3. Open in main door or applicable lint drawer/door switch circuit ...
 - a. Lint drawer/door switch not closed all the way.

- b. Lint drawer/door switch out of proper adjustment.
 - c. Fail lint drawer/door switch.
 - d. Failed main door switch.
 - e. Broken connection/wire in main door or lint drawer/door switch circuit.
4. Failed push to start relay.
 5. Failed 24 VAC step down transformer or fault in wiring.
 6. Failed heat timer.

B. Drive motor not operating (does not start) ...

1. Failed drive motor contactor (relay).
2. Failed drive motor.

C. Drive motor operates okay for a few minutes, and then stops and will not restart ...

1. Motor is overheating and tripping out on overload protector ...
 - a. Motor air vents clogged with lint.
 - b. Low voltage to the motor.
 - c. Failed motor.
 - d. Basket (tumbler) is binding ... check for obstruction.
 - e. Failed idler bearings or tumbler bearings.

D. Drive motor is not operating (does not start) and indicator light is on ...

1. Fault in L1 or L2 termination(s) between terminal block and contactor motor (relay).
2. Failed contactor.
3. Failed motor.

E. Heating unit is not operating (no heat) ... no voltage at heating unit (i.e., Gas Model - DSI module, Electric Model - electric oven contactor) ...

GAS MODELS

1. Fault in sail switch circuit ...
 - a. Sail switch is out of adjustment or has failed.
 - b. Sail switch damper is not closing or is fluttering ...

- 1) Lint drawer screen is dirty.
- 2) Restriction in exhaust.
- 3) No exhaust air flow ...
 - a) Failed impellor (fan/blower).
 - b) Fault in impellor (fan) motor circuit.
2. Failed Burner hi-limit switch.
3. Failed lint chamber sensor bracket basket (tumbler) hi-limit switch or circuit.
4. Failed temperature selection switch or circuit.
5. Failed temperature cycle thermostat (try another selection).
6. Failed heat timer.

ELECTRIC MODELS

1. Fault in sail switch circuit.
 - a. Sail switch damper is out of adjustment or has failed.
 - b. Sail switch damper is not closing or is fluttering ...
 - 1) Lint screen is dirty.
 - 2) Restriction in exhaust.
 - 3) No exhaust air flow ...
 - a) Failed impellor (blower/fan).
 - b) Fault in impellor (blower/fan) motor circuit.
 - c. Failed oven hi-limit switch.
 - d. Failed lint chamber sensor bracket basket (tumbler) hi-limit switch.
 - e. Failed temperature selection switch or circuit.
 - f. Failed temperature cycle thermostat (try another selection).
- F. No heat ... voltage is confirmed at heating unit (i.e., Gas Models - DSI module, Electric Model - electric oven contactor coil) ...**

GAS MODELS

1. Fault in Direct Spark Ignition (DSI) ignition system ...
 - a. Ignitor sparks but no ignition and Direct Spark Ignition (DSI) module locks out (RED L.E.D. indicator light stay on) ...
 - 1) Ignitor probe assembly is out of adjustment or has failed.
 - 2) Severe air turbulence.
 - 3) Failed Direct Spark Ignition (DSI) module.
 - 4) Failed gas valve.
 - b. Ignitor sparks, burner lights but goes off right away ...
 - 1) Direct Spark Ignition (DSI) ignitor out of adjustment ... or has failed.
 - 2) Sail switch is fluttering ...
 - a) Lint drawer screen is dirty.
 - b) Restriction in exhaust duct work.
 - c. Ignitor does not spark and Direct Spark Ignition (DSI) module locks out (RED L.E.D. indicator light is on) ...
 - 1) Fault in high voltage (HV) wire ... break or loose connection.
 - 2) Failed ignitor probe assembly.
 - 3) Failed Direct Spark Ignition (DSI) module.

ELECTRIC MODELS

1. Failed oven contactor or coil.
2. Failed electric oven element(s).

G. Dryer operates but is taking too long to dry ...

1. Exhaust duct work run too long or is undersized ... back pressure cannot exceed .3 inches water column (W.C.).
2. Restriction in exhaust ...
 - a. Exhaust back draft damper is sticking partially closed.
 - b. Restriction in duct work ... check duct work from dryer all the way to the outdoors.
3. Insufficient make-up air.

4. Impellor / blower / fan (**3-Phase [3Ø] Models ONLY**) rotating in the wrong direction.
5. Lint drawer screen is dirty or is not being cleaned often enough.
6. Inadequate air flow ...

- a. Impellor (blower / fan) failure.

7. GAS MODELS

- a. Low and/or inconsistent gas pressure (Gas Models ONLY) ... Natural Gas pressure **must be** between 3.5 inches and 4.0 inches of water column, and Liquid Propane (L.P.) pressure **must be** between 10.5 inches and 11.0 inches of water column.
- b. Poor air/gas mixture (too much gas or not enough air) at burner ... yellow or poor flame pattern ...
 - 1) Not enough make-up air.
 - 2) Restriction in exhaust.
 - 3) Gas pressure too high.
 - 4) Impellor / blower / fan (**3-Phase [3Ø] Models ONLY**) rotating in the wrong direction.
 - 5) Burner orifice size (D.M.S.) too large for application (i.e., high elevation).
- c. Sail switch is fluttering ... restriction in exhaust ...
 - 1) Lint drawer screen is dirty or is not being cleaned often enough.
 - 2) Restriction in exhaust.
- d. Failed burner hi-limit switch ... opens at incorrect temperature.
- e. Gas supply may have low heating value.

8. ELECTRIC MODELS

- a. Not enough make-up air.
- b. Restriction in exhaust.
- c. Lint screen is dirty or is not being cleaned often enough.
- d. Impellor (blower / fan) is rotating in the wrong direction (**3-Phase [3Ø] Models ONLY**).
- e. Sail switch is fluttering ...
 - 1) Restriction in exhaust.
 - 2) Sail switch not adjusted properly.

H. Main burners are burning with a yellow flame (for GAS MODELS ONLY) ...

1. Poor air / gas mixture (too much gas or not enough air) at burner ...
 - a. Not enough make-up air.
 - b. Restriction in exhaust.
 - c. Gas pressure too high.
 - d. Impellor (blower / fan) is rotating in the wrong direction (**3-Phase [3Ø] Models ONLY**).
 - e. Burner orifice size (D.M.S.) too large for application (i.e., high elevation).

I. Condensation on main door glass ...

1. Too long, undersized, or improperly installed duct work.
2. Back draft damper in duct work is sticking in partially closed position.

J. Dryer or scraping noise at basket (tumbler) area ...

1. Check for object caught in basket (tumbler)/wrapper area.
2. Basket (tumbler) is out of proper alignment.
 - a. Check both vertical alignment and lateral alignment.
 - b. Check gap between front panel and basket (tumbler) ... set screws may have come loose, and basket (tumbler) walked forward or backward.
3. Loose basket (tumbler) tie rod.
4. Failed basket (tumbler) support.

K. Excessive noise and/or vibration ...

1. Dryer is not leveled properly.
2. Impellor (fan / blower) is out of balance.
 - a. Excessive lint build-up impellor (fan / blower).
 - b. Failed impellor (fan / blower).
3. Loose basket (tumbler) tie rod.
4. Basket (tumbler) is out of adjustment, or adjustment bolts (hardware) are loose.
5. Failed basket (tumbler) support.
6. Loose motor mount.

7. Failed idler, basket (tumbler, or fan (impellor) bearings.
8. V-belt(s) either too tight or too loose.
9. Bearing set screws (basket [tumbler], idler, or impellor [blower] shaft) are loose.
10. Failed motor bearings.

SECTION VIII

REVERSING TIMER SPIN/DWELL

ADJUSTMENTS

Dual timer models with "reversing option" have an electric reversing timer in the electric service box which is located in the upper rear area of the dryer.

Both the dwell (stop) time and basket (tumbler) spin time are adjustable by mode selection switches located on the electronic timer (as noted in the illustration below).

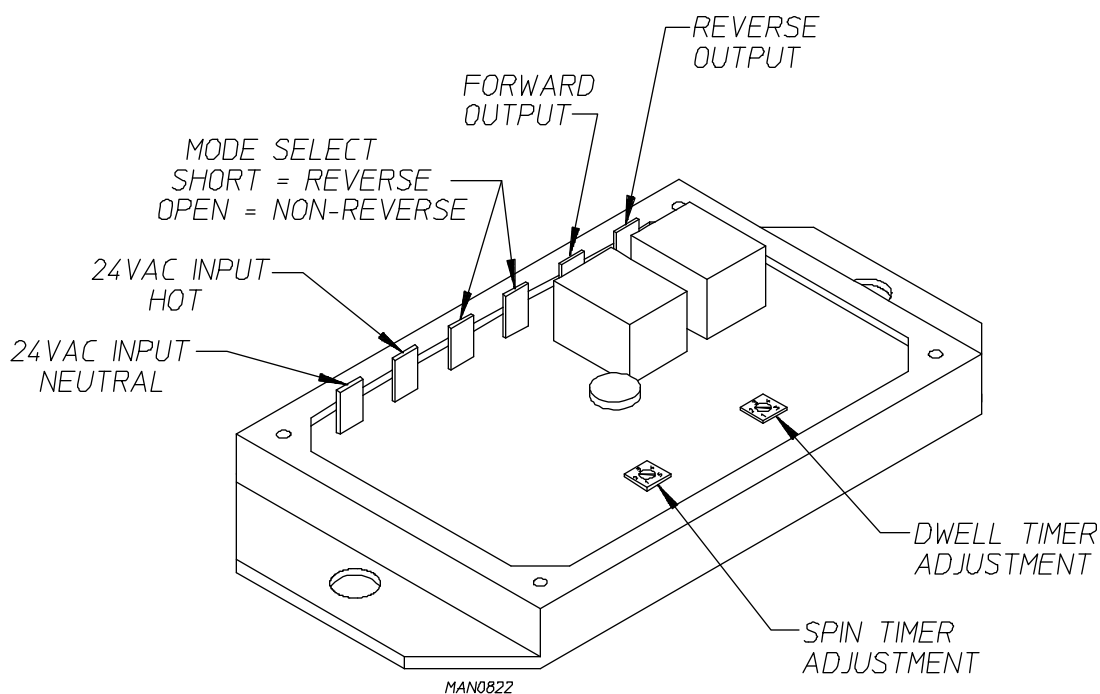

Timing Legend					
Spin Time					
Switch Position Number	1	2	3	4	5
Time in Seconds*	30	60	90	120	150
dd					
Dwell (Stop) Time	1	2	3	4	5
Switch Position Number	5	6	8	10	12
Time in Seconds*					
* Values shown are +/- 1 second.					

- e. Open main door. The dryer **must stop** and **ALL** indicator lights on the back side of the microprocessor (computer) board **must go out**.
- f. Try to restart the dryer with the main door open.
- g. The microprocessor (computer) board's L.E.D. display **must read "DOOR."**
- h. Close the main door and restart the dryer.
- i. Functional check of microprocessor (computer) board is complete.

2. Direct Spark Ignition (DSI) System

- a. Upon completing installation of the replacement Direct Spark Ignition (DSI) module, reestablish power to the dryer.
- b. Start the drying cycle.
- c. The ignition (DSI) module's L.E.D. indicator will light "red" for up to approximately 1.5 seconds (prepurge time).
- d. The module's indicator light will then turn "green." The gas valve will be energized and the ignitor probe will spark for approximately 8 seconds. The burner flame should now be established.
- e. With the burner flame on, remove the flame sensor wire from the FS terminal of the DSI module.
- f. The burner flame **must shut off** and the ignition module **must lock out** with the DSI module's indicator light "red."

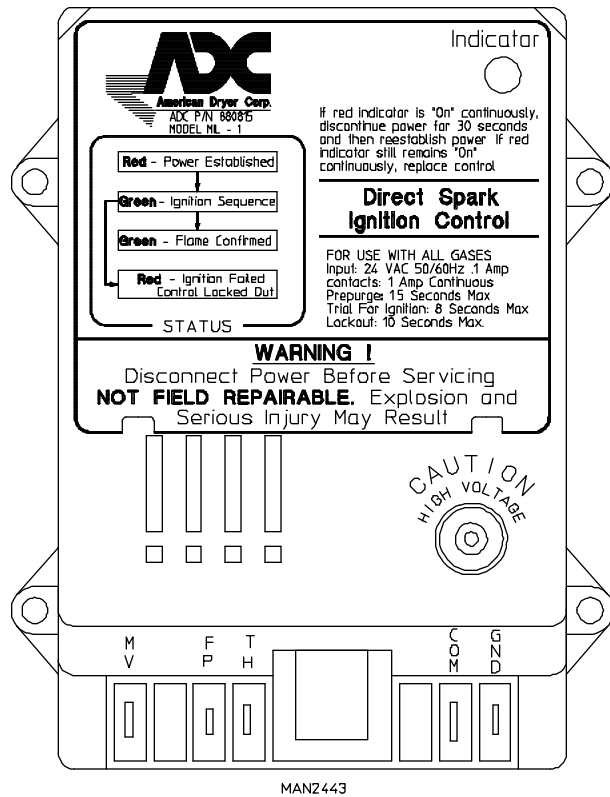

- g. Stop the drying cycle, with the flame sensor wire still removed, restart the drying cycle.
- h. The ignition module **must proceed** through the prepurge, with the indicator light "red," the ignition trial time of approximately 8 seconds, with the indicator light "green," and then proceed to lock out with the indicator light "red."
- i. Functional check of the Direct Spark Ignition (DSI) Module is complete.
 - 1) Replace the flame sensor wire from the FS terminal to the DSI module.

