

AD-285 Phase 7 Installation Manual

WARNING: For your safety the information in this manual must be followed to minimize the risk of fire or explosion or to prevent property damage, personal injury or death.

— Do not store or use gasoline or other flammable vapors and liquids in the vicinity of this or any other appliance.

— **WHAT TO DO IF YOU SMELL GAS:**

- Do not try to light any appliance.
- Do not touch any electrical switch; do not use any phone in your building.
- Clear the room, building or area of all occupants.
- Immediately call your gas supplier from a neighbor's phone. Follow the gas supplier's instructions.
- If you cannot reach your gas supplier, call the fire department.

— Installation and service must be performed by a qualified installer, service agency or the gas supplier.

AVERTISSEMENT: Assurez-vous de bien suivre les instructions données dans cette notice pour réduire au minimum le risque d'incendie ou d'explosion ou pour éviter tout dommage matériel, toute blessure ou la mort.

— Ne pas entreposer ni utiliser d'essence ni d'autres vapeurs ou liquides inflammables à proximité de cet appareil ou de tout autre appareil.

— **QUE FAIRE SI VOUS SENTEZ UNE ODEUR DE GAZ:**

- Ne pas tenter d'allumer d'appareils.
- Ne touchez à aucun interrupteur. Ne pas vous servir des téléphones se trouvant dans le bâtiment.
- Évacuez la pièce, le bâtiment ou la zone.
- Appelez immédiatement votre fournisseur de gaz depuis un voisin. Suivez les instructions du fournisseur.
- Si vous ne pouvez rejoindre le fournisseur de gaz, appelez le service des incendies.

— L'installation et l'entretien doivent être assurés par un installateur ou un service d'entretien qualifié ou par le fournisseur de gaz.



For replacement parts, contact the reseller from which the dryer was purchased or

American Dryer Corporation

88 Currant Road

Fall River MA 02720-4781

Telephone: (508) 678-9000 / Fax: (508) 678-9447

E-mail: techsupport@amdry.com

www.amdry.com

Retain This Manual In A Safe Place For Future Reference

American Dryer Corporation products embody advanced concepts in engineering, design, and safety. If this product is properly maintained, it will provide many years of safe, efficient, and trouble free operation.

ONLY qualified technicians should service this equipment.

OBSERVE ALL SAFETY PRECAUTIONS displayed on the equipment or specified in the installation manual included with the dryer.

The following “**FOR YOUR SAFETY**” caution **must be** posted near the dryer in a prominent location.

FOR YOUR SAFETY

Do not store or use gasoline or other flammable vapors and liquids in the vicinity of this or any other appliance.

POUR VOTRE SÉCURITÉ

Ne pas entreposer ni utiliser d'essence ni d'autres vapeurs ou liquides inflammables à proximité de cet appareil ou de tout autre appareil.

We have tried to make this manual as complete as possible and hope you will find it useful. **ADC** reserves the right to make changes from time to time, without notice or obligation, in prices, specifications, colors, and material, and to change or discontinue models. The illustrations included in this manual may not depict your particular dryer **exactly**.

Important

For your convenience, log the following information:

DATE OF PURCHASE _____ **MODEL NO.** AD-285 Phase 7

RESELLER'S NAME _____

Serial Number(s) _____

Replacement parts can be obtained from your reseller or the **ADC** factory. When ordering replacement parts from the factory, you can FAX your order to **ADC** at (508) 678-9447 or telephone your order directly to the **ADC** Parts Department at (508) 678-9000. Please specify the dryer **model number** and **serial number** in addition to the **description** and **part number**, so that your order is processed accurately and promptly.

“IMPORTANT NOTE TO PURCHASER”

Information **must be** obtained from your local gas supplier on the instructions to be followed if the user smells gas. These instructions **must be** posted in a prominent location near the dryer.

IMPORTANT

YOU MUST DISCONNECT AND LOCKOUT THE ELECTRIC SUPPLY AND THE GAS SUPPLY OR THE STEAM SUPPLY BEFORE ANY COVERS OR GUARDS ARE REMOVED FROM THE MACHINE TO ALLOW ACCESS FOR CLEANING, ADJUSTING, INSTALLATION, OR TESTING OF ANY EQUIPMENT PER OSHA (Occupational Safety and Health Administration) STANDARDS.

“Caution: Label all wires prior to disconnection when servicing controls. Wiring errors can cause improper operation.”

«Attention: Au moment de l'entretien des commandes, étiquetez tous les fils avant de les débrancher. Des erreurs de câblage peuvent entraîner un fonctionnement inadéquat et dangereux.»

CAUTION

DRYERS SHOULD NEVER BE LEFT UNATTENDED WHILE IN OPERATION.

WARNING

**CHILDREN SHOULD NOT BE ALLOWED TO PLAY ON OR NEAR THE DRYER(S).
CHILDREN SHOULD BE SUPERVISED IF NEAR DRYERS IN OPERATION.**

FOR YOUR SAFETY

DO NOT DRY MOP HEADS IN THE DRYER.

DO NOT USE DRYER IN THE PRESENCE OF DRY CLEANING FUMES.

WARNING

UNDER NO CIRCUMSTANCES should the dryer door switches, lint drawer switch, or heat safety circuit ever be disabled.

WARNING

The dryer *must never be* operated with any of the back guards, outer tops, or service panels removed. **PERSONAL INJURY OR FIRE COULD RESULT.**

WARNING

DRYER *MUST NEVER BE* OPERATED WITHOUT THE LINT FILTER/SCREEN IN PLACE, EVEN IF AN EXTERNAL LINT COLLECTION SYSTEM IS USED.

IMPORTANT

PLEASE OBSERVE ALL SAFETY PRECAUTIONS displayed on the equipment and/or specified in the installation manual included with the dryer.

Dryer *must not be* installed or stored in an area where it **will be** exposed to water or weather.

The wiring diagram for the dryer is located in the front electrical control box area.

IMPORTANT

Dryer *must be* installed in a location/environment, which the ambient temperature remains between 40° F (4.44° C) and 130° F (54.44° C).

Table of Contents

SECTION I

| | |
|------------------------------------|----------|
| IMPORTANT INFORMATION | 3 |
| A. Receiving and Handling | 3 |
| B. Safety Precautions | 4 |

SECTION II

| | |
|-----------------------------|----------|
| SPECIFICATIONS | 6 |
| A. Specifications | 6 |

SECTION III

| | |
|---|----------|
| INSTALLATION PROCEDURES | 8 |
| A. Unpacking/Setting Up | 8 |
| B. Location Requirements | 9 |
| C. Dryer Enclosure Requirements | 10 |
| D. Fresh Air Supply Requirements | 11 |
| E. Exhaust Requirements | 12 |
| F. Electrical Information | 18 |
| G. Gas Information | 23 |
| H. Preparation For Operation and Start-Up | 27 |
| I. Preoperational Tests | 28 |
| J. Preoperational Instructions | 29 |
| K. Shutdown Instructions | 30 |

SECTION IV

| | |
|--|-----------|
| SERVICE AND PARTS INFORMATION | 31 |
| A. Service | 31 |
| B. Parts | 31 |

SECTION V

| | |
|-----------------------------------|-----------|
| WARRANTY INFORMATION | 32 |
| A. Returning Warranty Cards | 32 |
| B. Warranty | 32 |
| C. Returning Warranty Parts | 32 |

SECTION VI

| | |
|----------------------------------|-----------|
| ROUTINE MAINTENANCE | 34 |
| A. Cleaning | 34 |
| B. Adjustments | 35 |
| C. Lubrication | 35 |

| | |
|-------------------------------------|-----------|
| SECTION VII | |
| DATA LABEL INFORMATION | 36 |
| A. Data Label | 36 |

| | |
|--|-----------|
| SECTION VIII | |
| PROCEDURE FOR FUNCTIONAL CHECK OF REPLACEMENT | |
| COMPONENTS..... | 38 |

| | |
|--|-----------|
| SECTION IX | |
| OPL SENSOR ACTIVATED FIRE EXTINGUISHING (S.A.F.E.) SYSTEM .. | 40 |
| Installation | 41 |
| Sensor Activated Fire Extinguishing (S.A.F.E.) Theory of Operation | 44 |
| System Reset | 44 |
| OPL S.A.F.E. System Check Procedure | 44 |
| Sensor Activated Fire Extinguishing (S.A.F.E.) System Parts Break Down | 45 |

| | |
|--|-----------|
| SECTION X | |
| COIN SENSOR ACTIVATED FIRE EXTINGUISHING (S.A.F.E.) SYSTEM | 47 |
| Installation | 48 |
| Sensor Activated Fire Extinguishing (S.A.F.E.) Theory of Operation | 51 |
| Disabled S.A.F.E. System | 51 |
| S.A.F.E. Diagnostic Messages | 51 |
| System Reset | 51 |
| Sensor Activated Fire Extinguishing (S.A.F.E.) System Parts Break Down | 52 |
| S.A.F.E. Sensor Probe Assembly | 54 |

SECTION I

IMPORTANT INFORMATION

A. RECEIVING AND HANDLING

The dryer is shipped in a protective stretch wrap cover with protective cardboard corners and top cover (or optional box) as a means of preventing damage in transit. Upon delivery, the dryer and packaging, and wooden skid **should be** visually inspected for shipping damage. If any damage whatsoever is noticed, inspect further before delivering carrier leaves.

Dryers damaged in shipment:

1. **ALL** dryers **should be** inspected upon receipt and before they are signed for.
2. If there is suspected damage or actual damage, the trucker's receipt **should be** so noted.
3. If the dryer is damaged beyond repair, it **should be** refused. Those dryers which were not damaged in a damaged shipment **should be** accepted, but the number received and the number refused **must be** noted on the receipt.
4. If you determine that the dryer was damaged after the trucker has left your location, you should call the delivering carrier's freight terminal immediately and file a claim. The freight company considers this concealed damage. This type of freight claim is very difficult to get paid and becomes extremely difficult when more than a day or two passes after the freight was delivered. It is your responsibility to file freight claims. Dryer and parts damaged in transit **cannot** be claimed under warranty.
5. Freight claims are the responsibility of the consignee, and **ALL** claims **must be** filed at the receiving end. **ADC** assumes no responsibility for freight claims or damages.
6. If you need assistance in handling the situation, please contact the **ADC** Traffic Manager at (508) 678-9000.

IMPORTANT: The dryer *must be* transported and handled in an upright position at **ALL** times.

B. SAFETY PRECAUTIONS

WARNING: For your safety, the information in this manual *must be* followed to minimize the risk of fire or explosion or to prevent property damage, personal injury, or loss of life.

WARNING: The dryer *must never be* operated with any of the back guards, outer tops, or service panels removed. **PERSONAL INJURY OR FIRE COULD RESULT.**

1. **DO NOT** store or use gasoline or other flammable vapors and liquids in the vicinity of this or any other appliance.
2. Purchaser or user should consult the local gas supplier for proper instructions to be followed in the event the user smells gas. The instructions **should be** posted in a prominent location.
3. WHAT TO DO IF YOU SMELL GAS...
 - a. **DO NOT** try to light any appliance.
 - b. **DO NOT** touch any electrical switch.
 - c. **DO NOT** use any phone in your building.
 - d. Clear the room, building, or area of **ALL** occupants.
 - e. Immediately call your gas supplier from a neighbor's phone. Follow the gas supplier's instructions.
 - f. If you **cannot** reach your gas supplier, call the fire department.
4. Installation and service **must be** performed by a qualified installer, service agency, or gas supplier.
5. Dryers **must be** exhausted to the outdoors.
6. Although **ADC** produces a very versatile dryer, there are some articles that, due to fabric composition or cleaning method, **should not be** dried in it.

WARNING: Dry only water washed fabrics. **DO NOT** dry articles spotted or washed in dry cleaning solvents, a combustible detergent, or "all purpose" cleaner.
EXPLOSION COULD RESULT.

WARNING: **DO NOT** dry rags or articles coated or contaminated with gasoline, kerosene, oil, paint, or wax.
EXPLOSION COULD RESULT.

WARNING: **DO NOT** dry mop heads. Contamination by wax or flammable solvents will create a fire hazard.

WARNING: **DO NOT** use heat for drying articles that contain plastic, foam, sponge rubber, or similarly textured rubberlike materials. Drying in a heated basket (tumbler) may damage plastics or rubber and may be a fire hazard.

7. A program **should be** established for the inspection and cleaning of lint in the burner area, exhaust ductwork, and area around the back of the dryer. The frequency of inspection and cleaning can best be determined from experience at each location.

WARNING: The collection of lint in the burner area and exhaust ductwork can create a potential fire hazard.

8. For personal safety, the dryer **must be** electrically grounded in accordance with local codes and/or the National Electrical Code ANSI/NFPA NO. 70-LATEST EDITION, or in Canada, the Canadian Electrical Codes Parts 1 & 2 CSA C22.1-1990 or LATEST EDITION.

NOTE: Failure to do so will VOID THE WARRANTY.

9. **UNDER NO CIRCUMSTANCES** should the dryer door switches, lint drawer switch, or heat safety circuit ever be disabled.

WARNING: PERSONAL INJURY OR FIRE COULD RESULT.

10. This dryer is not to be used in the presence of dry cleaning solvents or fumes.

11. Remove articles from the dryer as soon as the drying cycle has been completed.

WARNING: Articles left in the dryer after the drying and cooling cycles have been completed can create a fire hazard.

12. **READ AND FOLLOW ALL CAUTION AND DIRECTION LABELS ATTACHED TO THE DRYER.**

13. For safety, proper operation, and optimum performance, the dryer **must not be** operated with a load less than sixty-six percent (66%), 20 lbs (9.07 kg) of its rated capacity.

WARNING: YOU MUST DISCONNECT AND LOCKOUT THE ELECTRIC SUPPLY AND THE GAS SUPPLY BEFORE ANY COVERS OR GUARDS ARE REMOVED FROM THE MACHINE TO ALLOW ACCESS FOR CLEANING, ADJUSTING, INSTALLATION, OR TESTING OF ANY EQUIPMENT PER OSHA (Occupational Safety and Health Administration) STANDARDS.

IMPORTANT: Dryer *must be* installed in a location/environment, which the ambient temperature remains between 40° F (4.44° C) and 130° F (54.44° C).

SECTION II

SPECIFICATIONS

A. SPECIFICATIONS

| | | | |
|-------------------------------|---------------------------|--------------------------------------|-----------------------|
| MAXIMUM CAPACITY (DRY WEIGHT) | | 30 lbs. | 13.6 kg |
| BASKET (TUMBLER) DIAMETER | | 27-1/4" | 69.22 cm |
| BASKET (TUMBLER) DEPTH | | 30" | 76.2 cm |
| BASKET (TUMBLER) MOTOR | | 1/2 HP | .373 kw |
| DOOR OPENING (DIAMETER) | | 21-1/2" | 54.61 cm |
| BASKET (TUMBLER) VOLUME | | 10.18 cu. ft. | 0.288 cu. m. |
| DRYERS PER 20'/40' CONTAINER | | 14/30 | |
| DRYERS PER 45'/48' TRUCK | | 36/38 | |
| Gas | VOLTAGE AVAILABLE | 120-460v 1 ϕ -3 ϕ 50/60 Hz | |
| | APPROX. WEIGHT (UNCRATED) | 455 lbs. | 206.4 kg |
| | APPROX. WEIGHT (CRATED) | 500 lbs. | 226.8 kg |
| | HEAT INPUT | 72,000 btu/hr | 18,144 kcal/hr |
| | AIRFLOW | 375 cfm | 11 cmm |
| | INLET PIPE CONNECTION | 1/2" N.P.T. | |

Shaded areas are stated in metric equivalents

NOTE: ADC reserves the right to make changes in specifications at any time without notice or obligation.

Specifications

ADG-285

DRYER NOTES:

- DUCTWORK SIZE VARIES WITH INSTALLATION CONDITIONS.
- EXHAUST STATIC PRESSURE MUST BE NO LESS THAN 0 AND MUST NOT EXCEED 0.3" (0.74 MB) WATER COLUMN.

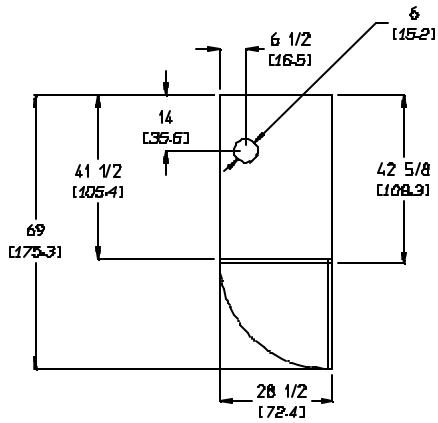

PLAN VIEW

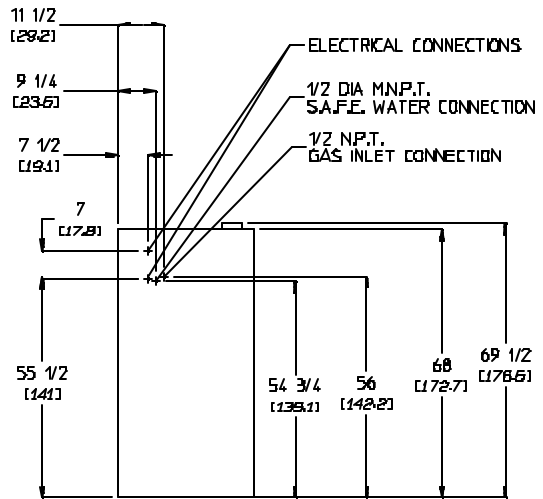

REAR VIEW

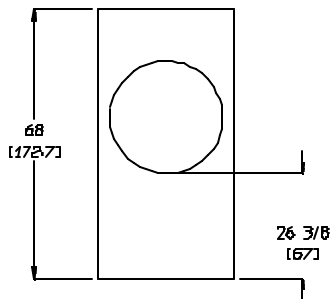

FRONT VIEW

PSS 2/20/03

NOTE: ADC reserves the right to make changes in specifications at any time without notice or obligation.

SECTION III

INSTALLATION PROCEDURES

Installation **should be** performed by competent technicians in accordance with local and state codes. In the absence of these codes, the installation **must conform** to applicable American National Standards: ANSI Z223.1-LATEST EDITION (National Fuel Gas Code) or ANSI/NFPA NO. 70-LATEST EDITION (National Electrical Code) or in Canada, the installation **must conform** to applicable Canadian Standards: CAN/CGA-B149.1-M91 (Natural Gas) or CAN/CGA-B149.2-M91 (Liquid Propane [L.P.] Gas) or LATEST EDITION (for General Installation and Gas Plumbing) or Canadian Electrical Codes Parts 1 & 2 CSA C22.1-1990 or LATEST EDITION (for Electrical Connections).

A. UNPACKING/SETTING UP

Remove protective shipping material (i.e., plastic wrap and optional shipping box) from dryer.

IMPORTANT: Dryer *must be* transported and handled in an upright position at **ALL** times.

NOTE: For OPL (non-coin) dryer models equipped with locks, the lock used is a dummy lock and no key is supplied or needed. The lock can be turned with any key, a screwdriver, a small coin, or any small sharp object. For coin-operated dryers, the MK-100 (master key for both the control door and lint door) *should be* made accessible because it **will be** needed throughout various phases in the installation of the dryer.

The dryer can be moved to its final location while still attached to the skid or with the skid removed. To unskid the dryer, locate and remove the four (4) bolts securing the base of the dryer to the wooden skid. Two (2) are at the rear base (remove the back panel for access), and two (2) are located in the bottom of the lint chamber. To remove the two (2) bolts located in the lint chamber area, remove the lint door.

With the skid removed, to make it easier to slide the dryer into its final position, slightly lower **ALL** four (4) leveling legs, so that the dryer will slide on the legs instead of the base frame.

To increase bearing life and improve efficiency, the dryer **should be** tilted slightly to the rear.

1. Leveling Dryer

The dryer is equipped with four (4) leveling legs, one (1) at each corner of the base. Two (2) are located at the rear of the dryer base, and two (2) are located in the lint chamber (coop). To increase bearing life and improve efficiency, the dryer **should be** tilted slightly to the rear.

B. LOCATION REQUIREMENTS

Before installing the dryer, be sure the location conforms to local codes and ordinances. In the absence of such codes or ordinances the location **must conform** with the National Fuel Gas Code ANSI.Z223.1-LATEST EDITION, or in Canada, the installation **must conform** to applicable Canadian Standards: CAN/CGA-B149.1-M91 (Natural Gas) or CAN/CGA-B149.2-M91 (Liquid Propane [L.P.] Gas) or LATEST EDITION (for General Installation and Gas Plumbing).

1. The dryer **must be** installed on a sound level floor capable of supporting its weight. Carpeting **must be** removed from the floor area that the dryer is to rest on.

IMPORTANT: “The dryer *must be* installed on noncombustible floors only.”

2. The dryer **must not be** installed or stored in an area where it will be exposed to water or weather.
3. The dryer is for use in noncombustible locations.
4. Provisions for adequate air supply **must be** provided as noted in this manual (refer to **Fresh Air Supply Requirements** in Section D).
5. Clearance provisions **must be** made from combustible construction as noted in this manual (refer to **Dryer Enclosure Requirements** in Section C).
6. Provisions **must be** made for adequate clearances for servicing and for operation as noted in this manual (refer to **Dryer Enclosure Requirements** in Section C).
7. Dryer **must be** exhausted to the outdoors as noted in this manual (refer to **Exhaust Requirements** in Section E).
8. Dryer **must be** located in an area where correct exhaust venting can be achieved as noted in this manual (refer to **Exhaust Requirements** in Section E).

IMPORTANT: Dryer *should be* located where a minimum amount of exhaust duct will be necessary.

9. The dryer **must be** installed with a proper exhaust duct connection to the outside.
10. The dryer **must be** installed with provisions for adequate combustion and make-up air supply.

CAUTION: This dryer produces combustible lint and *must be* exhausted to the outdoors. Every 6 months, inspect the exhaust ducting and remove any lint build up.

IMPORTANT: Dryer *must be* installed in a location/environment, which the ambient temperature remains between 40° (4.44° C) and 130° F (54.44° C).

C. DRYER ENCLOSURE REQUIREMENTS

Bulkheads and partitions **should be** made of noncombustible materials and **must be** located a minimum of 12-inches (30.48 cm) above the dryer's outer top; except along the front of the dryer which may be closed if desired.

NOTE: Allowances **must be** made for opening the control door.

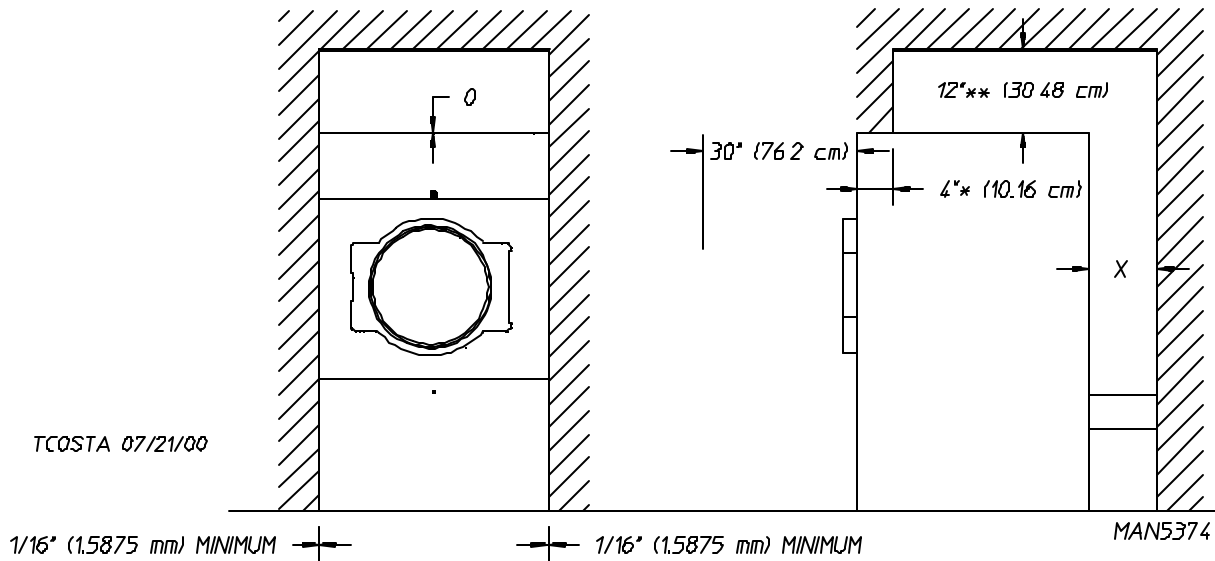

X = 12-inch (30.48 cm) minimum, 24-inches (60.96 cm) is suggested for ease of maintenance.

NOTE: Air considerations are important for proper and efficient operation.

Dryers may be positioned sidewall to sidewall. However, a 1/16" (1.5875 mm) minimum allowance **must be** made for the opening and closing of the control door and the lint door. It is suggested that the dryer be positioned about 2 feet (0.61 meters) away from the nearest obstruction for ease of installation, maintenance, and service (to be measured from the back guard). Refer to the **illustration above** for details.

D. FRESH AIR SUPPLY REQUIREMENTS

The dryer air supply (make-up air) **must be** given careful consideration to assure proper performance of each dryer. An unrestricted source of air is necessary for each dryer. As a general rule, an unrestricted air entrance from the outdoors (atmosphere) of a minimum of 1 square foot (0.09 square meters) is required for each dryer. If registers or louvers are installed over the openings, then the area **must be** increased. It is not necessary to have a separate make-up air opening for each dryer. Common make-up air openings are acceptable. However, they **must be** set up in such a manner that the make-up air is distributed equally to the dryers. The dryer **must be** installed with provisions for adequate combustion and make-up air supply.

EXAMPLE: For a bank of eight (8) dryers, two (2) unrestricted openings measuring 2 feet by 2 feet (0.61 meters by 0.61 meters), 4 square feet (0.372 square meters) each. A total of 8 square feet (0.744 square meters) is acceptable.

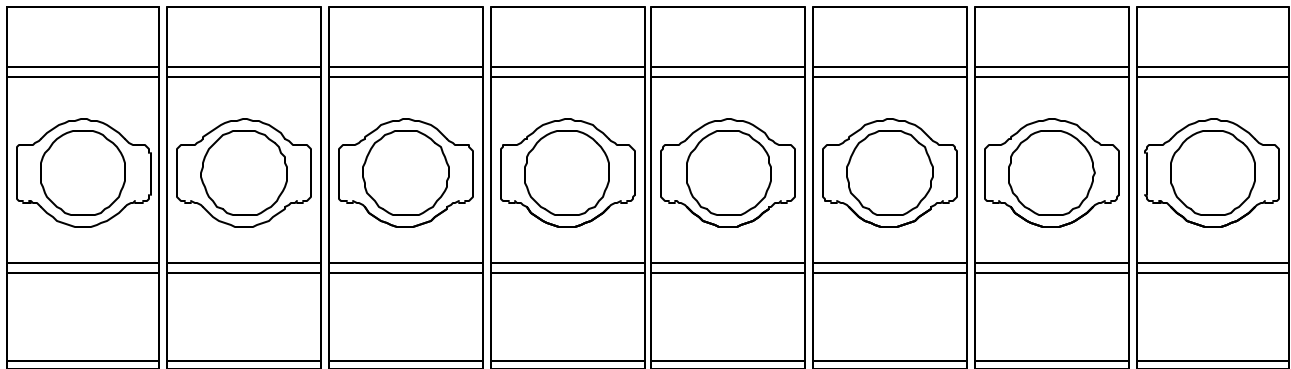
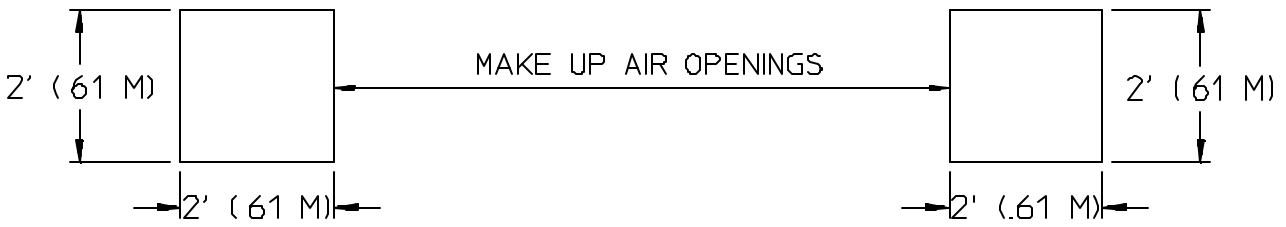

MAN4733

TYPICAL INSTALLATION SHOWING MAKE - UP AIR OPENINGS

IMPORTANT: Make-up air openings *should not be* located in an area directly near where exhaust vents exit the building.

Allowances **must be** made for remote or constricting passageways or where dryers are located at excessive altitudes or predominantly low pressure areas.

IMPORTANT: Make-up air *must be* provided from a source free of dry cleaning solvent fumes. Make-up air that is contaminated by dry cleaning solvent fumes will result in irreparable damage to the motors and other dryer components.

NOTE: Component failure due to dry cleaning solvent fumes will VOID THE WARRANTY.

E. EXHAUST REQUIREMENTS

Exhaust ductwork **should be** designed and installed by a qualified professional. Improperly sized ductwork will create excessive back pressure which results in slow drying, increased use of energy, and shutdown of the burner by the airflow (sail) switch, burner hi-limit, or lint chamber hi-heat protector thermostat. The dryer **must be** installed with a proper exhaust duct connection to the outside.

CAUTION: This dryer produces combustible lint and **must be** exhausted to the outdoors.

When possible, it is suggested to provide a separate (single) exhaust duct for each dryer.

CAUTION: IMPROPERLY SIZED OR INSTALLED EXHAUST DUCTWORK CAN CREATE A POTENTIAL FIRE HAZARD.

CAUTION: DRYER *MUST BE* EXHAUSTED TO THE OUTDOORS.

IMPORTANT: It is recommended that exhaust or booster fans not be used in the exhaust ductwork system.

The exhaust ductwork **should be** laid out in such a way that the ductwork travels as directly as possible to the outdoors with as few turns as possible. The shape of the ductwork is not critical so long as the minimum cross section area is provided. Single or independent dryer venting is recommended.

It is suggested that the use of 90° turns be avoided; use 30° or 45° angles instead.

The ductwork **should be** smooth inside with no projections from sheet metal screws or other obstructions, which will collect lint. When adding ducts, the ducts to be added should overlap the duct to which it is connected. **ALL** ductwork joints **must be** taped to prevent moisture and lint from escaping into the building. Additionally, inspection doors **should be** installed at strategic points in the exhaust ductwork for periodic inspection and cleaning.

IMPORTANT: When connecting ductwork to the dryer exhaust duct, be sure that when screws are used they **DO NOT** restrict the operation (both opening and closing) of the damper.

NOTE: When the exhaust ductwork passes through a wall, ceiling, or roof made of combustible materials, the opening **must be** 2 inches (5.08 cm) larger than the duct (all the way around). The duct **must be** centered within this opening.

To protect the outside end of the horizontal ductwork from the weather, a 90° elbow bent downward **should be** installed where the exhaust exits the building. If the ductwork travels vertically up through the roof, it **should be** protected from the weather by using a 180° turn to point the opening downward. In either case, allow at least twice the diameter of the duct between the duct opening and the nearest obstruction (i.e., roof or ground level).

IMPORTANT: *DO NOT* use screens, louvers, or caps on the outside opening of the exhaust ductwork.

IMPORTANT: Exhaust back pressure measured by a manometer at the dryer exhaust duct area **must be** no less than 0 and **must not exceed** 0.3 inches (0.74 mb) of water column (W.C.).

NOTE: As per the National Fuel Gas Code, “Exhaust ducts for type 2 clothes dryers shall be constructed of sheet metal or other noncombustible material. Such ducts shall be equivalent in strength and corrosion resistance to ducts made of galvanized sheet steel not less than 0.0195-inches (26 gauge [0.05 mm]) thick.”

SINGLE DRYER VENTING

IMPORTANT: For exhaust duct runs over 40 feet (12 meters) a minimum size of 10-inches (25.4 cm) *must be* used.

HORIZONTAL VENTING

When horizontal single 8-inch (20.32 cm) venting is used, the ductwork to the outlet **cannot** exceed 40 feet (12 meters) refer to **Illus. A below**. This calculation of 40 feet (12 meters) compensates or allows for the use of a maximum of two (2) elbows.

Illus. A *HORIZONTAL SINGLE DRYER
VENTING 8 INCH (20.32 CM) DUCTING*

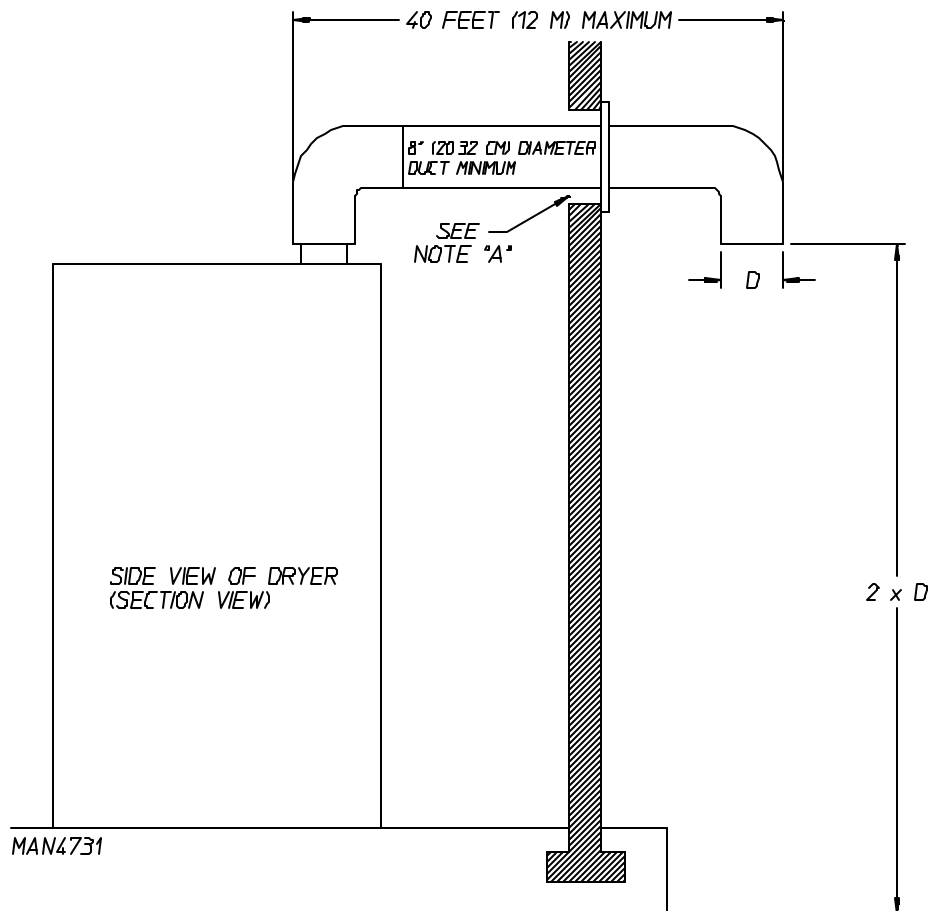

NOTE A OPENING MUST BE 2 INCHES (5.08 CM) LARGER THAN THE DUCT (ALL THE WAY AROUND)
THE DUCT MUST BE CENTERED WITHIN THIS OPENING

VERTICAL VENTING

When vertical single venting is used minimum duct size is 8-inches (20.32 cm), refer to **Illus. B below**, the ductwork from the dryer to the outside outlet **cannot** exceed 60 feet (18 meters), refer to **Illus. B below**. This calculation compensates for the use of a maximum of two (2) elbows. These are the two (2) elbows that create the 180° (turned downward) outside outlet.

Illus. B

VERTICAL SINGLE DRYER VENTING

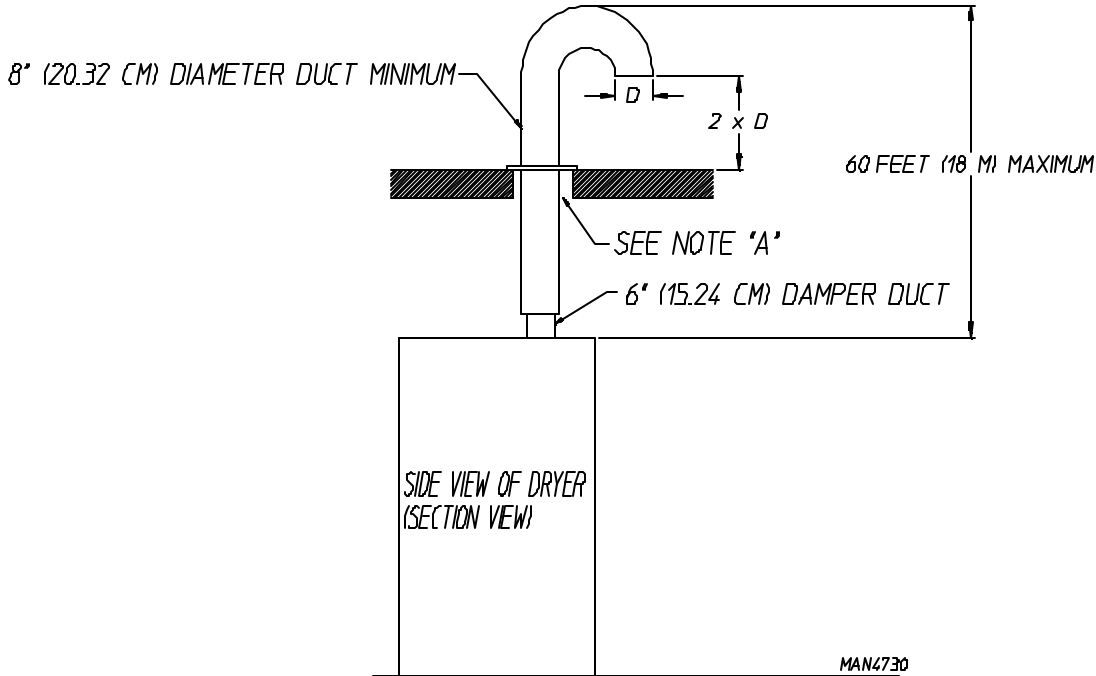

NOTE A: OPENING MUST BE 2 INCHES (5.08 CM) LARGER THAN THE DUCT (ALL THE WAY AROUND) THE DUCT MUST BE CENTERED WITHIN THIS OPENING.

If the length of the duct run or quantity of elbows used exceeds the above noted specifications, the cross section area of the ductwork **must be** increased in proportion to the number of elbows or duct run added.

IMPORTANT: For extended ductwork runs, the cross section area of the duct can only be increased to an extent. For extended ductwork runs, a professional heating, venting, and air conditioning (HVAC) firm **should be** consulted for proper venting information.

IMPORTANT: It is recommended that exhaust or booster fans not be used in the exhaust ductwork system.

MULTIPLE DRYER (COMMON) VENTING

HORIZONTAL VENTING

If it is not feasible to provide separate exhaust ducts for each dryer, ducts for individual dryers may be channeled into a common main duct. Each dryer is provided with a back draft damper. The individual ducts should enter the bottom or side of the main duct at an angle not more than 45° in the direction of the airflow. No more than eight (8) dryers **should be** connected to one (1) main common duct run.

The main common duct may be any shape so long as the minimum cross-sectional area is provided. The main duct **should be** tapered with the diameter increasing before each individual 8-inch (20.32 cm) duct is added (refer to **Illus. C** below and **Illus. D** on page 16).

Illus. C

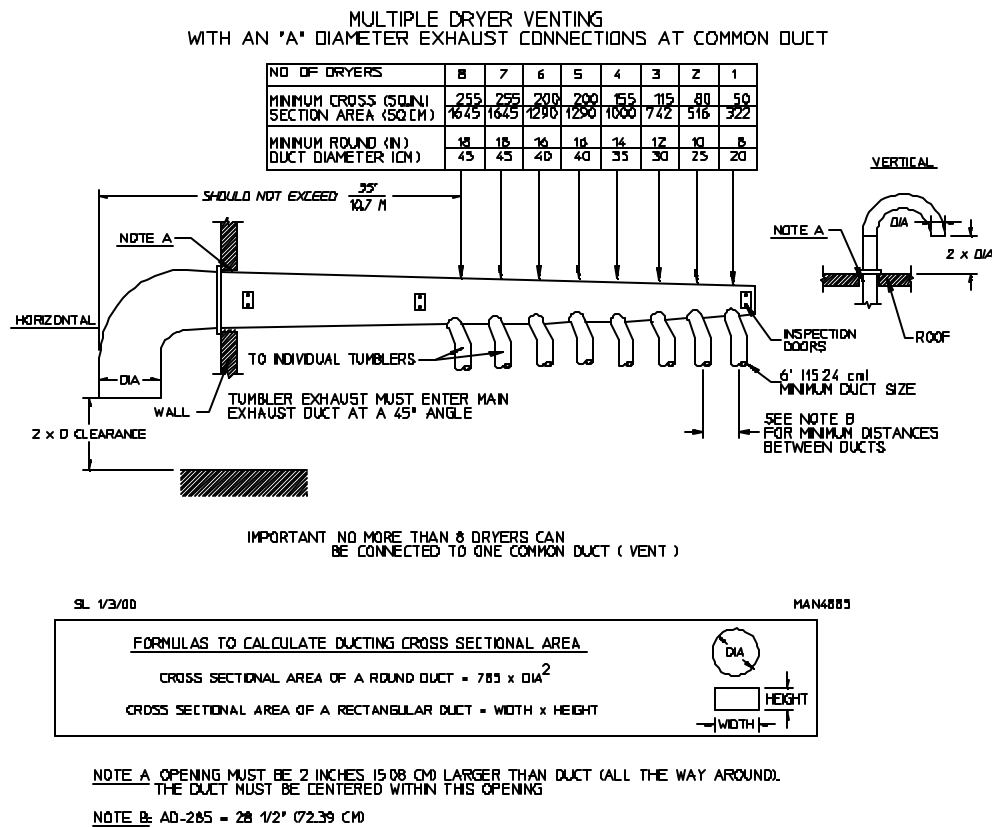

Horizontal venting **must not exceed** 35 feet (10.7 meters), this calculation compensates for the use of a maximum of only one (1) elbow, which is the outside outlet protection.

NOTE: Distance between dryer single ducts being connected to the main common duct **must be** a minimum of 28-1/2" (72.39 cm) dryer width.

Ductwork **should be** laid out in such a manner where allowances are made at rear area of the dryer for removal of rear service panels or guards.

Illus. C (refer to the **above illustration**) shows the minimum cross section area for horizontal multiple dryer venting. These figures **must be** increased in proportion if the main duct run from the last dryer to where it exhausts has numerous elbows or is unusually long.

IMPORTANT: For extended ductwork runs, the cross section area of the duct can only be increased to an extent. For extended ductwork runs, a professional heating, venting, and air conditioning (HVAC) firm *should be* consulted for proper venting information.

VERTICAL VENTING

Illus. D

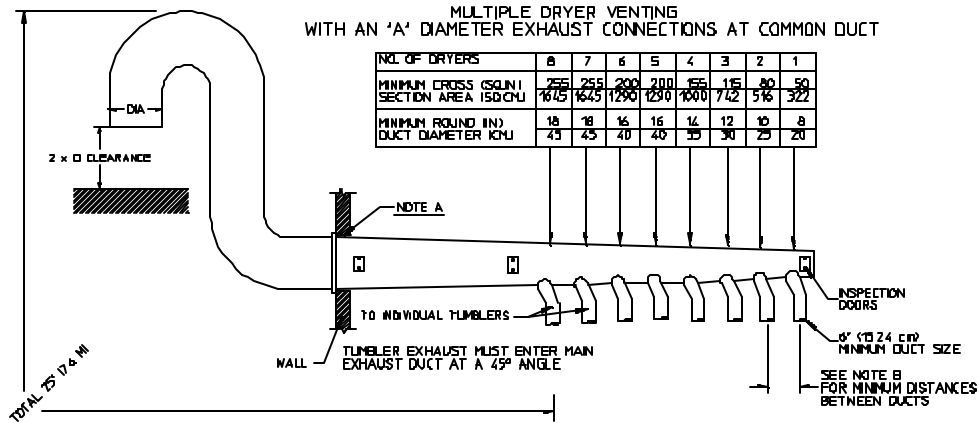

IMPORTANT: NO MORE THAN 8 DRYERS CAN BE CONNECTED TO ONE COMMON DUCT (VENT)

FORMULAS TO CALCULATE DUCTING CROSS SECTIONAL AREA

CROSS SECTIONAL AREA OF A ROUND DUCT = .785 x DIA²

CROSS SECTIONAL AREA OF A RECTANGULAR DUCT = WIDTH x HEIGHT

NOTE A: OPENING MUST BE 2 INCHES (50.8 CM) LARGER THAN DUCT (ALL THE WAY AROUND) THE DUCT MUST BE CENTERED WITHIN THIS OPENING.

NOTE B: AD-285 - 28 1/2" (72.39 CM)

SL 1/3/00

The maximum length of venting from the last dryer to where it exhausts.

Vertical venting **must not exceed** 25 feet (7.6 meters), this calculation compensates for the use of a maximum of three (3) elbows including the two (2) elbows creating the 180° (turned downward) outside outlet protection.

IMPORTANT: No more than eight (8) dryers maximum *should be* connected to one (1) main common duct with a vertical run.

NOTE: Distance between dryer single ducts being connected to the main common duct *must be* a minimum of 28-1/2" (72.39 cm) dryer width.

Ductwork *should be* laid out in such a manner where allowances are made at rear area of the dryer for removal of rear service panels or guards.

Illus. D (refer to the **above illustration**) shows the minimum cross section area for vertical multiple dryer venting. These figures **must be** increased in proportion if the main duct run from the last dryer to where it exhausts has numerous elbows or is unusually long.

IMPORTANT: For extended ductwork runs, the cross section area of the duct can only be increased to an extent. For extended ductwork runs, a professional HVAC firm *should be* consulted for proper venting information.

IMPORTANT VENTING REMINDERS

1. Ductwork size and installation **should be** done by a qualified professional.
2. The dryer **must be** exhausted to the outdoors.
3. Ductwork **should be** routed as short as possible to the outdoors with as few elbows as possible.
4. Avoid 90° turns, use 30° or 45° turns instead.
5. The size of the ductwork **must be** a minimum of 8-inches (20.32 cm).
6. The inside of the ductwork **should be** as smooth as possible with no projections from sheet metal screws.
Ducts added should overlap the duct to which it is to be connected.
7. **ALL** ducts **should be** taped to prevent moisture and lint from escaping into the building.
8. Inspection or clean out doors **should be** installed throughout strategic points in the ductwork for periodic inspection and cleaning.
9. Whenever the duct passes through combustibile materials, the opening **must be** 2-inches (5.08 cm) larger than the duct (all the way around). The duct **must be** centered within this opening.
10. The outside of the ductwork **must be** protected from the weather. A 90° elbow **must be** used for horizontal run and when vertically through a roof by using a 180° turn to point the opening downward. The distance between the exhaust duct and the nearest obstruction (i.e., roof or ground) **must be** twice the diameter of the duct.
11. **DO NOT** use screens, louvers, or caps on the outside opening of the exhaust ductwork.
12. Exhaust back pressure measured by a manometer at the dryer exhaust duct area **must be** no less than 0 and **must not exceed** 0.3 inches (0.74 mb) of water column (W.C.).
13. **WARNING**- DRYER **MUST NEVER BE** OPERATED WITHOUT THE LINT FILTER AND SCREEN IN PLACE, EVEN IF AN EXTERNAL LINT COLLECTION SYSTEM IS USED.
14. Exhaust ductwork outlets **should not be** located in an area directly where the make-up air openings are located.

IMPORTANT: It is recommended that exhaust or booster fans not be used in the exhaust ductwork system.

NOTE: As per the National Fuel Gas Code, “Exhaust ducts for type 2 clothes dryers shall be constructed of sheet metal or other noncombustible material. Such ducts shall be equivalent in strength and corrosion resistance to ducts made of galvanized sheet steel not less than 0.0195-inches (26 gauge [0.05 mm]) thick.”

F. ELECTRICAL INFORMATION

1. Electrical Requirements

It is your responsibility to have **ALL** electrical connections made by a properly licensed and competent electrician to assure that the electrical installation is adequate and conforms to local and state regulations or codes. In the absence of such codes, **ALL** electrical connections, materials, and workmanship **must conform** to the applicable requirements of the National Electrical Code ANSI/NFPA NO. 70-LATEST EDITION, or in Canada, the Canadian Electrical Codes Parts 1 & 2 CSA C22.1-1990 or LATEST EDITION.

IMPORTANT: Failure to comply with these codes or ordinances, or the requirements stipulated in this manual can result in personal injury or component failure.

NOTE: Component failure due to improper installation will VOID THE WARRANTY.

IMPORTANT: Each circuit *must be* connected to an independently protected branch circuit.

IMPORTANT: USE ONLY COPPER CONDUCTOR CABLE of proper ampacity and insulation in accordance with electric codes for making service connections.

NOTE: The use of aluminum wire will VOID THE WARRANTY.

IMPORTANT: A separate circuit servicing each dryer *must be* provided.

2. Electrical Service Specifications

| ADG-285 (Gas) | | | | | |
|--|-------|---------------|------------------|-------|-----------------|
| ELECTRICAL SERVICE SPECIFICATIONS (PER DRYER) | | | | | |
| <p>IMPORTANT: 208 VAC AND 240 VAC <u>ARE NOT THE SAME</u>. When ordering, specify exact voltage.</p> <p>NOTES:</p> <p>A. When fuses are used they must be dual element, time delay, current limiting, class RK1 or RK5 ONLY. Calculate/determine correct fuse value, by applying either local and/or National Electrical Codes to listed appliance amp draw data.</p> <p>B. Circuit breakers are thermal-magnetic (industrial) motor curve type ONLY. For others, calculate/verify correct breaker size according to appliance amp draw rating and type of breaker used.</p> <p>C. Circuit breakers for 3-phase (3Ø) dryers must be 3-pole type.</p> | | | | | |
| SERVICE VOLTAGE | PHASE | WIRE SERVICE* | APPROX. AMP DRAW | | CIRCUIT BREAKER |
| | | | 60 Hz | 50 Hz | |
| 120 | 1Ø | 2 | 8.7 | -- | 15 |
| 208 | 1Ø | 2 | 5.2 | -- | 15 |
| 240 | 1Ø | 2 | 4.8 | 5.6 | 15 |
| 208 | 3Ø | 3 | 3.0 | -- | 15 |
| 240 | 3Ø | 3 | 3.2 | 3.6 | 15 |
| 380-400 | 3Ø | 4** | -- | 2.2 | 15 |
| 416 | 3Ø | 4** | -- | 2.3 | 15 |
| 460-480 | 3Ø | 3 | 2.1 | -- | 15 |

* AWG Stranded Type Wire...size wire as per National Electrical Code or local codes.

** 380, 400, 416 Volt dryers are built (4-wire) only. Customer must contact factory to special order (3-wire) systems.

IMPORTANT: The dryer **must be** connected to the electric supply shown on the data label that is affixed to either the backside of the upper control door or left side panel/wall area behind the control door. In the case of 208 VAC or 240 VAC, the supply voltage must match the electric service specifications of the data label **exactly**.

IMPORTANT: The wire size **must be** properly sized to handle the related current.

WARNING: **208 VAC AND 240 VAC ARE NOT THE SAME**. Any damage done to dryer components due to improper voltage connections will automatically **VOID THE WARRANTY**.

NOTE: ADC reserves the right to make changes in specifications at any time without notice or obligation.

3. Grounding

A ground (earth) connection **must be** provided and installed in accordance with state and local codes. In the absence of these codes, grounding **must conform** to applicable requirements of the National Electrical Code ANSI/NFPA NO. 70-LATEST EDITION, or in Canada, the installation **must conform** to applicable Canada Standards: Canadian Electrical Codes Parts 1 & 2 CSA C22.1-1990 or LATEST EDITION. The ground connection may be to a proven earth ground at the location service panel.

For added personal safety, when possible, it is suggested that a separate ground wire (no. 18 minimum) be connected from the ground connection of the dryer to a grounded cold water pipe. **DO NOT ground to a gas pipe or hot water pipe.** The grounded cold water pipe must have metal to metal connection **ALL** the way to the electrical ground. If there are any nonmetallic interruptions, such as, a meter, pump, plastic, rubber, or other insulating connectors, they **must be** jumped with no. 4 copper wire and securely clamped to bare metal at both ends.

IMPORTANT: For personal safety and proper operation, the dryer **must be** grounded.

Provisions are made for ground connection in each dryer at the electrical service connection area.

4. Electrical Connections

A wire diagram is located inside the control box for connection data.

NOTE: A CIRCUIT SERVICING EACH DRYER MUST BE PROVIDED.

a. Single-Phase (1 ϕ) Wiring Connections and Hookup

The electrical input connections on **ALL** single-phase (1 ϕ) dryers are made into the rear service box located at the upper left area of the dryer.

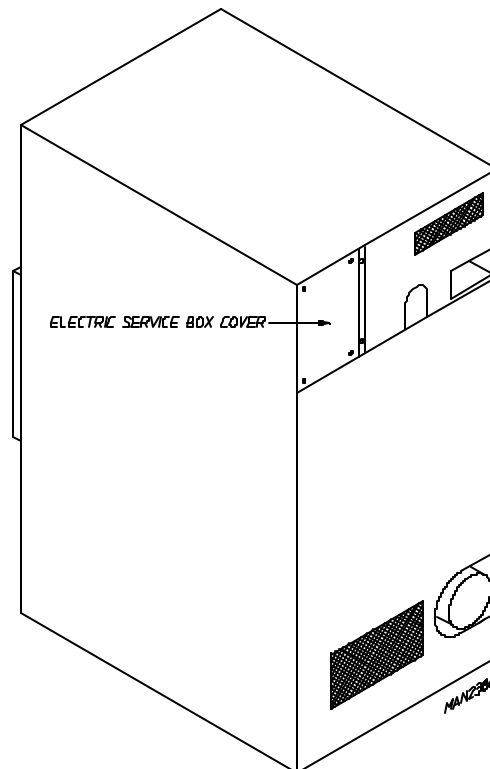

| SINGLE-PHASE (1Ø) ELECTRICAL CONNECTIONS LEADS | | |
|--|-----------------------|-----------------|
| Black + Positive | White - Neutral | Green Ground |
| or L2 | | |

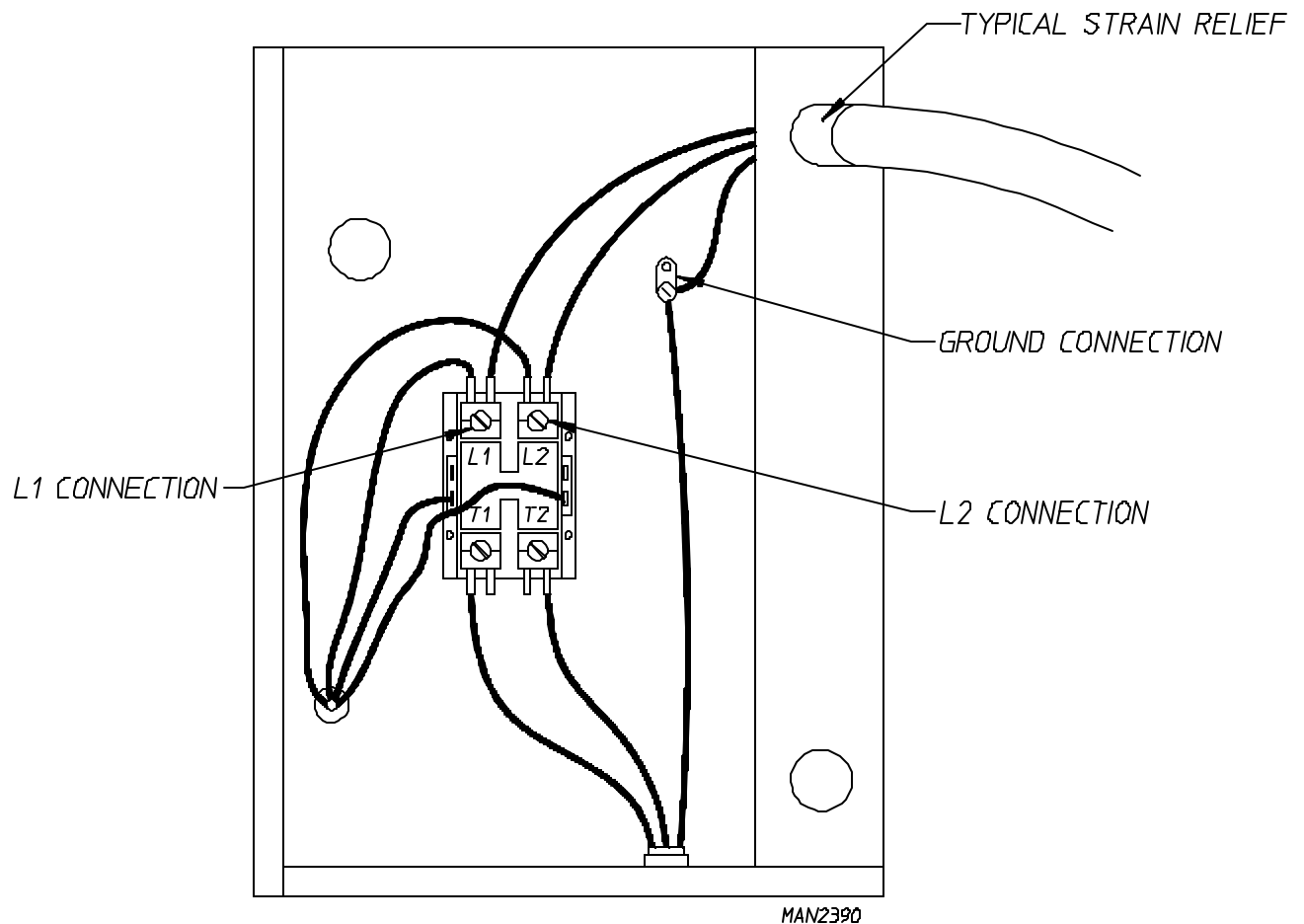

If local codes permit, power to the dryer can be made by the use of a flexible U.L. listed power cord or pigtail (wire size **must conform** to rating of dryer), or the dryer can be hard wired directly to the service breaker panel. In both cases, a strain relief **must be** installed where the wiring enters the dryer.

5. 3-Phase (3 ϕ) Wiring Connections and Hookup

The only electrical input connections to the dryer are the 3-phase (3 ϕ) power leads (L1, L2, L3, and sometimes Neutral) and ground. Single-phase (1 ϕ) power for the control circuit is done internally to the dryer. No single-phase (1 ϕ) input connection is required on a 3-phase (3 ϕ) dryer.

IMPORTANT: A CIRCUIT SERVICING EACH DRYER *MUST BE* PROVIDED.

a. 3-Phase (3 ϕ) Wiring Connections and Hookup

For dryers manufactured for operation at 3-phase (3 ϕ), the electrical connections are made at the power distribution block located in the service box at the rear, upper left corner of the dryer. The ground connection is made to the copper lug also provided in this box. To gain access to the service box and contactor, the service box cover **must be** removed.

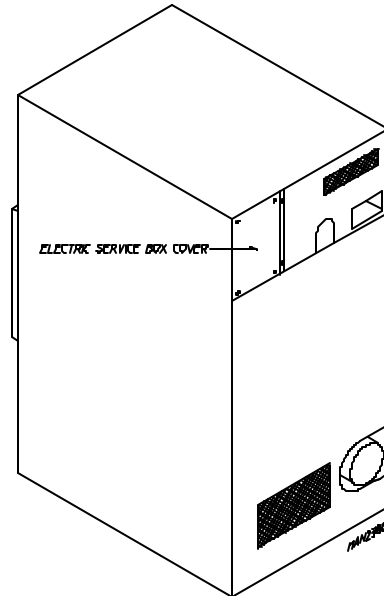

Providing local codes permit, power to a dryer can be made by the use of a flexible U.L. listed power cord or pigtail (wire size **must conform** to rating of dryer), or the dryer can be hard wired directly to the service breaker panel. In **ALL** cases, a strain relief **must be** installed where the wiring enters the dryer and service box area.

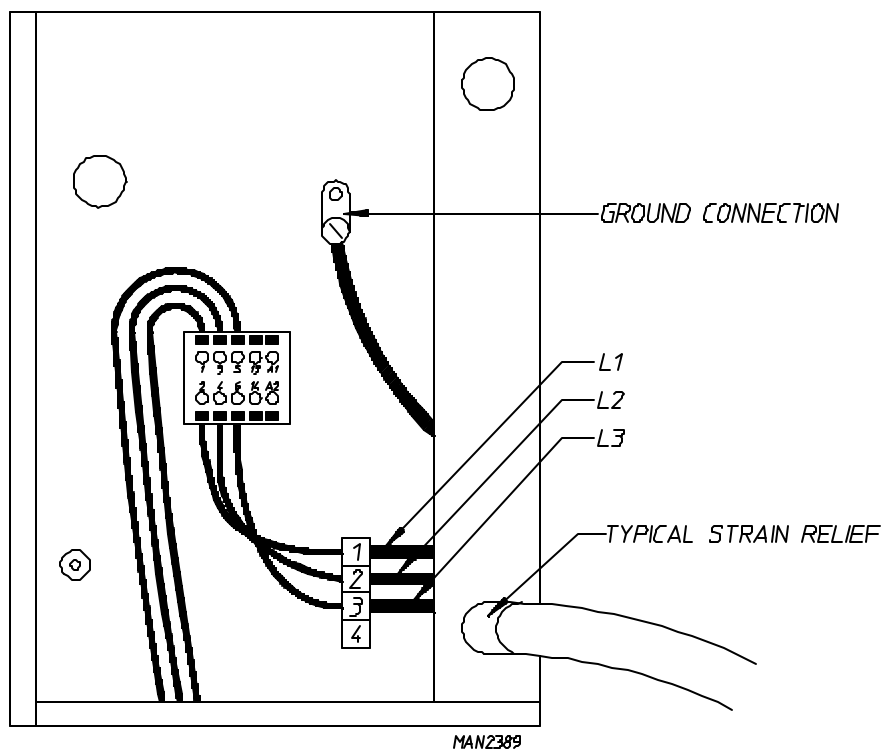

G. GAS INFORMATION

It is your responsibility to have **ALL** plumbing connections made by a qualified professional to assure that the gas plumbing installation is adequate and conforms to local and state regulations or codes. In the absence of such codes, **ALL** plumbing connections, materials, and workmanship **must conform** to the applicable requirements of the National Fuel Gas Code ANSI Z223.1-LATEST EDITION, or in Canada, the Canadian Installation Codes CAN/CGA-B149.1-M91 (Natural Gas) or CAN/CGA-B149.2-M91 (Liquid Propane [L.P.] Gas) or LATEST EDITION.

IMPORTANT: Failure to comply with codes or ordinances, and/or requirements in this manual, can result in personal injury and improper operation of the dryer.

The dryer and its individual shutoff valves **must be** disconnected from the gas supply piping system during any pressure testing of that system at test pressures in excess of 1/2 psig (3.5 kPa). The dryer **must be** isolated from the gas supply piping system by closing its individual manual shutoff valve during any pressure test of the gas supply system at test pressures equal to or less than 1/2 psig (3.5 kPa).

IMPORTANT: Failure to isolate or disconnect the dryer from supply as noted can cause irreparable damage to the gas valve, which will VOID THE WARRANTY.

WARNING: FIRE OR EXPLOSION COULD RESULT.

1. Gas Supply

The gas dryer installation **must meet** the American National Standard: National Fuel Gas Code ANSI Z223.1-LATEST EDITION, or in Canada, the Canadian Installation Codes CAN/CGA-B149.1-M91 (Natural Gas) or CAN/CGA-B149.2-M91 (L.P. Gas) or LATEST EDITION, as well as local codes and ordinances and **must be** done by a qualified professional.

NOTE: Undersized gas piping will result in ignition problems, slow drying, increased use of energy, and can create a safety hazard.

The dryer **must be** connected to the type of heat or gas indicated on the dryer data label affixed to either the backside of the upper control door or left side panel/wall area behind the control door. If this information does not agree with the type of gas available, **DO NOT operate the dryer**. Contact the reseller who sold the dryer or contact the **ADC** factory.

IMPORTANT: Any burner changes or conversions **must be** made by a qualified professional.

The input ratings shown on the dryer data label are for elevations up to 2,000 feet (609.6 meters), unless elevation requirements of over 2,000 feet (609.6 meters) were specified at the time the dryer order was placed with the factory. The adjustment or conversion of dryers in the field for elevations over 2,000 feet (609.6 meters) is made by changing each burner orifice. If this conversion is necessary, contact the reseller who sold the dryer or contact the **ADC** factory.

IMPORTANT: THIS GAS DRYER **IS NOT** PROVIDED WITH AN INTERNAL GAS SUPPLY SHUTOFF AND AN EXTERNAL GAS SUPPLY SHUTOFF **MUST BE** PROVIDED.

2. Technical Gas Data

a. Gas Specifications

| TYPE OF GAS | | | | |
|--------------------|------------------------|------------------------|------------------|----------------|
| | NATURAL | | LIQUID PROPANE | |
| Manifold Pressure* | 3.5 inches W.C. | 8.7 mb | 10.5 inches W.C. | 26.1 mb |
| In-Line Pressure | 6.0 - 12.0 inches W.C. | 14.92 - 29.9 mb | 11.0 inches W.C. | 27.4 mb |

Shaded areas are stated in metric equivalents

*Measured at the outlet side of gas valve pressure tap when gas valve is on.

b. Gas Connections

Inlet connection ----- 1/2" N.P.T.
 Inlet supply size ----- 1/2" N.P.T. (minimum)
 Btu/hr input (per dryer) ----- 72,000 (18,144 kcal/hr)

1) Natural Gas

Regulation is controlled by the dryer's gas valve's internal regulator. Incoming supply pressure **must be** consistent between a minimum of 6.0 inches (14.92 mb) and a maximum of 12.0 inches (29.9 mb) water column (W.C.) pressure.

2) Liquid Propane (L.P.) Gas

Dryers made for use with L.P. gas valve's internal pressure regulator blocked open so that the gas pressure **must be** regulated upstream of the dryer. The pressure measured at each gas valve pressure tap **must be** a consistent 10.5 inches (26.1 mb) water column. There is no regulator or regulation provided in an L.P. dryer. The water column pressure **must be** regulated at the source (L.P. tank) or an external regulator **must be** added to each dryer.

| | | | TYPE OF GAS | | | | | | L.P. Conversion Kit Part Number |
|------------------------|---------------------------|-------------------|--------------------|---------|----------------|----------------|---------|----------------|--|
| ADC MODEL NUMBER | BTU Per Hour Rating | kcal/hr Rating | Natural | | | Liquid Propane | | | |
| | | | Qty. | D.M.S.* | Part Number | Qty. | D.M.S.* | Part Number | |
| ADG-285D | 72,000 | 18,144 | 2 | #33 | 140855 | 2 | #51 | 140801 | 874054 |

Shaded area is stated in metric equivalent

* Drill Measurement Size (D.M.S.) equivalents are as follows:

Natural Gas #33 = 0.1130" (2.8702 mm).
 Liquid Propane Gas #51 = 0.0670" (1.7018 mm).

3. Piping Connections

ALL components/materials **must conform** to National Fuel Gas Code Specifications ANSI Z223.1-LATEST EDITION, or in Canada, CAN/CGA-B149.1-M91 (Natural Gas) or CAN/CGA-B149.2-M91 (Liquid Propane [L.P.] Gas) or LATEST EDITION (for General Installation and Gas Plumbing), as well as local codes and ordinances and **must be** done by a qualified professional. It is important that gas pressure regulators meet applicable pressure requirements, and that gas meters be rated for the total amount of **ALL** the appliance BTUs being supplied.

The dryer is provided with a 1/2" N.P.T. inlet pipe connection located in the upper rear of the dryer. The minimum pipe size (supply line) to the dryer is 1/2" N.P.T. For ease in servicing, the gas supply line of each dryer must have its own shutoff valve.

IMPORTANT: THIS GAS DRYER **IS NOT** PROVIDED WITH AN INTERNAL GAS SUPPLY SHUTOFF AND AN EXTERNAL GAS SUPPLY SHUTOFF **MUST BE** PROVIDED.

IMPORTANT: The gas supply line to each dryer **must be** a minimum of 1/2-inch. **DO NOT** REDUCE THIS PIPE SIZE REQUIREMENT.

The size of the main gas supply line (header) will vary depending on the distance this line travels from the gas meter or, in the case of L.P. gas, the supply tank, other gas-operated appliances on the same line, etc. Specific information regarding supply line size **should be** determined by the gas supplier.

NOTE: Undersized gas supply piping can create a low or inconsistent pressure, which will result in erratic operation of the burner ignition system.

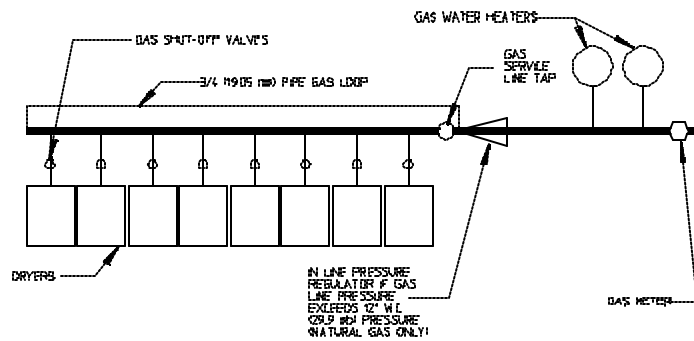

TYPICAL NATURAL GAS INSTALLATION

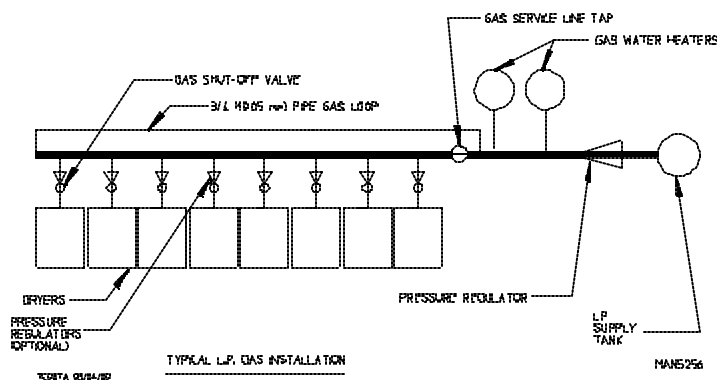

TYPICAL L.P. GAS INSTALLATION

Consistent gas pressure is essential at **ALL** gas connections. It is recommended that a 3/4-inch (19.05 mm) pipe gas loop be installed in the supply line servicing a bank of dryers. An in-line pressure regulator **must be** installed in the gas supply line (header) if the (natural) gas pressure exceeds 12.0 inches (29.9 mb) of water column (W.C.) pressure. Refer to the **illustrations** on the previous page.

NOTE: A water column test pressure of 3.5 inches (8.7 mb) for natural gas and 10.5 inches (26.1 mb) for liquid propane (L.P.) dryers is required at the gas valve pressure tap of each dryer for proper and safe operation.

A 1/8" N.P.T. plugged tap, accessible for a test gauge connection, **must be** installed in the main gas supply line immediately upstream of each dryer.

IMPORTANT: Pipe joint compounds that resist the action of natural gas and L.P. gas **must be** used.

IMPORTANT: Test **ALL** connections for leaks by brushing on a soapy water solution (liquid detergent works well).

WARNING: NEVER TEST FOR LEAKS WITH A FLAME!!!

ALL components/materials **must conform** to National Fuel Gas Code Specifications ANSI Z223.1-LATEST EDITION, or in Canada, CAN/CGA-B149.1-M91 (Natural Gas) or CAN/CGA-B149.2-M91 (L.P. Gas) or LATEST EDITION (for General Installation and Gas Plumbing), as well as local codes and ordinances and **must be** done by a qualified professional. It is important that gas pressure regulators meet applicable pressure requirements, and that gas meters be rated for the total amount of **ALL** the appliance BTUs being supplied.

IMPORTANT: The dryer and its individual shutoff valve **must be** disconnected from the gas supply piping system during any pressure testing of that system at test pressures in excess of 1/2 psig (3.5 kPa).

NOTE: The dryer **must be** isolated from the gas supply piping system by closing its individual manual shutoff valve during any pressure test of the gas supply system at test pressures equal to or less than 1/2 psig (3.5 kPa).

IMPORTANT: THIS GAS DRYER **IS NOT** PROVIDED WITH AN INTERNAL GAS SUPPLY SHUTOFF AND AN EXTERNAL GAS SUPPLY SHUTOFF **MUST BE** PROVIDED.

H. PREPARATION FOR OPERATION AND START-UP

The following items **should be** checked before attempting to operate the dryer:

1. Read **ALL** “**CAUTION**,” “**WARNING**,” and “**DIRECTION**” labels attached to the dryer.
2. Check incoming supply voltage to be sure that it is the same as indicated on the dryer data label affixed to either the backside of the upper control door or left side panel/wall area behind the control door.
3. Check to assure that the dryer is connected to the type of heat or gas indicated on the dryer data label.
4. The sail switch damper assembly was installed and adjusted at the factory prior to shipping. However, each sail switch adjustment **must be** checked to assure that this important safety control is functioning.
5. Check bolts, nuts, screws, terminals, and fittings for tightness.
6. Be sure that **ALL** gas shutoff valves are in the open position.
7. Check **ALL** back guard panels and service box covers have been replaced.
8. Make sure the lint coop support bracket has been removed.
9. Check the lint door to assure that it is closed and secured in place.

| |
|--|
| <p>IMPORTANT: If during installation the lint door safety chain was disconnected, it <i>must be</i> reconnected or personal injury may result.</p> |
|--|

10. Rotate the basket (tumbler and drum) by hand to be sure it moves freely.
11. Check bolts, nuts, screws, terminals, and fittings for security.
12. Check basket (tumbler) bearing setscrews to insure that they are **ALL** tight.

I. PREOPERATIONAL TESTS

ALL dryers are thoroughly tested and inspected before leaving the factory. However, a preoperational test **should be** performed before the dryer is publicly used. It is possible that adjustments have changed in transit or due to marginal location (installation) conditions.

1. Turn on electric power to the dryer.
2. Refer to the Operating Instructions for starting your particular model dryer.
 - a. When a gas dryer is first started (during initial start-up), it has a tendency not to ignite on the first ignition attempt. This is because the gas supply piping is filled with air, so it may take a few minutes for the air to be purged from the lines.

NOTE: During the purging period, check to be sure that **ALL** gas shutoff valves are open.

NOTE: Gas model dryers are equipped with a Direct Spark Ignition (DSI) system, which has internal diagnostics. If ignition **is not** established after the first attempt, the heat circuit in the DSI module will lockout until it is manually reset. To reset the DSI system, open and close the main door and restart the dryer.

- b. A gas pressure test **should be** taken at the gas valve pressure tap of each dryer to assure that the water column (W.C.) pressure is correct and consistent.

NOTE: Water column pressure requirements (measured at the pressure tap of the gas valve body):

Natural Gas ----- 3.5 Inches (8.7 mb) Water Column.

Liquid Propane (L.P.) Gas - 10.5 Inches (26.1 mb) Water Column.

IMPORTANT: There is no regulator provided in an L.P. dryer. The water column pressure **must be** regulated at the source (L.P. tank), or an external regulator **must be** added to each dryer.

3. Make a complete operational check of **ALL** safety related circuits:
 - a. Door Switches
 - b. Hi-Limit Thermostats
 - c. Cycling Thermostat
 - d. Sail Switch

NOTE: The sail switch can be checked for proper operation by opening the lint door while the heating circuit (gas burner) is active (on). The heating until should shut off within a few seconds. If not, make necessary adjustments to the sail switch.

4. Make a complete operational check of **ALL** operating controls.

NOTE: If computer program changes are required, refer to the computer programming section of the manual supplied with the dryer.

5. The dryer **should be** operated through one (1) complete cycle to assure that no further adjustments are necessary and that **ALL** components are functioning properly.

BASKET (TUMBLER) COATING

The basket (tumbler) is treated with a protective coating. We suggest dampening old garments or cloth material with a solution of water and nonflammable mild detergent and tumbling them in the basket (tumbler) to remove this coating.

6. Check the electric service phase sequence (3-phase [3 ϕ] models only). While the dryer is operating, check to see if the blower (squirrel cage fan) is rotating in the proper direction. Looking from the front, the blower (squirrel cage fan) should spin in the clockwise (CW) direction. If it is, the phasing is correct. If the phasing is incorrect, reverse two (2) of the three (3) leads at connections L1, L2, and L3 of the power supply to the dryer.

IMPORTANT: If the blower (squirrel cage fan) is rotating in the wrong direction, this **will not** only drastically reduce drying efficiency, but it can also cause premature component failure.

J. PREOPERATIONAL INSTRUCTIONS

1. COIN MODELS

a. Microprocessor Controller (computer)

- 1) When the microprocessor controller (computer) is in the ready state, the liquid crystal display (L.C.D.) screen will display "Ready, Insert \$XX.XX (amount) to Start."
- 2) Insert coin(s). Once the correct "Amount To Start" has been inserted, the L.C.D. will display "Select Temperature."
- 3) Select temperature by pressing "HI," "PP," or "LO." The cycle will start and the L.C.D. will display the Dry Cycle selected and the remaining time.
- 4) The dryer will continue through the drying and cooling cycles, until the vended time has expired.

NOTE: To stop dryer, open main door. Continuation of the cycle will resume only after the door has been closed and any of the three (3) temperature is pressed.

- 5) Upon completion of drying and cooling cycles, the tone (buzzer) will sound and the dryer will go into the Anti-Wrinkle mode for 99 minutes, or until the main door has been opened.

IMPORTANT: For more detailed information regarding the microprocessor controller (computer) on your dryer, refer to the MP User's manual included with the dryer.

b. Mechanical Drop/Rotary Coin Meter or Slide Coin Meter

- 1) Insert coin and turn knob (rotary type meter), or for slide meter unit, push in coin chute.
- 2) Select Temperature.



- 3) Push the “Start” button.
- 4) To stop dryer, open the main door.

2. NON-COIN (OPL) MODELS

a. Microprocessor controller (computer) dryers...

- 1) Light emitting diode (L.E.D.) display will read “REAdY” (meaning no cycle in progress).
- 2) Press the letter on the keyboard (touch pad) corresponding to the cycle desired (i.e., key “E”)...
 - a) The dryer will then start (rotate).
- 3) L.E.D. display will now show “Cycle In Progress” and “Cycle Status” meaning that the dryer is in the drying cycle (dry mode for 30 minutes) and count downwards in minutes.

NOTE: Pressing keyboard (touch pad) key “A,” “B,” “C,” “D,” or “F” will also start the dryer. The six (6) preprogrammed drying cycles “A” through “F” have been stored in the microprocessor controller (computer) memory. Refer to the Programming Manual supplied with the dryer for more specific operating instructions.

NOTE: The dryer can be stopped at any time by opening the main door or by pressing the “STOP”  red key. To restart the dryer, press the “START”  green key or a preprogrammed cycle key (i.e., “E”).

NOTE: Selection (settings) changes can be made at any time during the drying cycle by pressing the “STOP”  red key twice. The L.E.D. display will return to “REAdY” at which time a new cycle selection can be made.

b. Dual timer dryers

- 1) Turn drying timer knob for a time of 20 minutes.
- 2) Select “High Temp.”
- 3) Push “Push To Start” switch.
- 4) To stop dryer, open the main door.
 - a) Spin and dwell (stop) times are adjustable at the reversing timer.

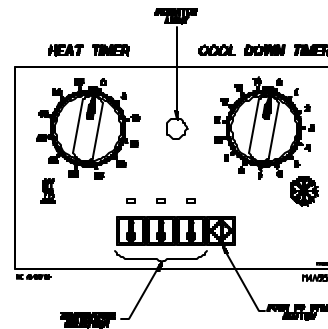

K. SHUTDOWN INSTRUCTIONS

If the dryer is to be shutdown (taken out of service) for a period of time, the following **must be** performed:

1. Discontinue power to the dryer either at the external disconnect switch or the circuit breaker.
2. Discontinue the heat supply:
 - a. **GAS MODEL...discontinue the gas supply.**
 - 1) **SHUT OFF external gas supply shutoff valve.**
 - 2) **SHUT OFF internal gas supply shutoff valve located in the gas valve burner area.**

SECTION IV

SERVICE AND PARTS INFORMATION

A. SERVICE

1. Only properly licensed or trained technicians should service the dryer. If service is required, contact the reseller from whom the **ADC** equipment was purchased. If the reseller **cannot** be contacted or is unknown, contact the **ADC** Service Department for a reseller in your area.

NOTE: When contacting the **ADC** Service Department, be sure to give them the correct **model number** and **serial number** so that your inquiry is handled in an expeditious manner.

B. PARTS

1. Replacement parts **should be** purchased from the reseller from whom the **ADC** equipment was purchased. If the reseller **cannot** be contacted or is unknown, contact the **ADC** Parts Department for a reseller in your area. Parts may also be purchased directly from the factory by calling the **ADC** Parts Department at (508) 678-9000 or you may FAX in your order at (508) 678-9447.

NOTE: When ordering replacement parts from the **ADC** reseller or the **ADC** factory be sure to give them the correct **model number** and **serial number** so that your parts order can be processed in an expeditious manner.

SECTION V

WARRANTY INFORMATION

A. RETURNING WARRANTY CARDS

1. Before any dryer leaves the **ADC** factory test area, a warranty card is placed on the back side of the main door glass. These warranty cards are intended to serve the customer where we record the individual installation date and warranty information to better serve you should you file a warranty claim.
 - a. If a warranty card did not come with your dryer, contact the **ADC** Warranty Department or the **ADC** Service Department at (508) 678-9000.

IMPORTANT: A separate warranty card *must be* completed and returned for each individual dryer.

NOTE: Be sure to include the installation date when returning the warranty card(s).

B. WARRANTY

For a copy of the **ADC** commercial warranty covering your particular dryer(s), contact the **ADC** reseller from whom you purchased the equipment and request a dryer warranty form. If the reseller **cannot** be contacted or is unknown, warranty information can be obtained from the factory by contacting the **ADC** Warranty Department at (508) 678-9000.

NOTE: Whenever contacting the **ADC** factory for warranty information, be sure to have the dryer's **model number** and **serial number** available so that your inquiry can be handled in an expeditious manner.

C. RETURNING WARRANTY PARTS

ALL dryer or parts warranty claims or inquires **should be** addressed to the **ADC** Warranty Parts Department. To expedite processing, the following procedures **must be** followed:

1. No parts are to be returned to **ADC** without prior written authorization ("Return Material Authorization" [R.M.A.]) from the factory.

NOTE: An R.M.A. is valid for only thirty (30) days from date of issue.

- a. The R.M.A. issued by the factory, as well as any other correspondence pertaining to the returned part(s), **must be** included inside the package with the failed merchandise.

2. Each part **must be** tagged with the following information:
 - a. **Model number** and **serial number** of the dryer from which part was removed.
 - b. Nature of failure (be specific).
 - c. Date of dryer installation.
 - d. Date of part failure.
 - e. Specify whether the part(s) being returned is for a replacement, a credit, or a refund.

NOTE: If a part is marked for a credit or a refund, the invoice number covering the purchase of the replacement part **must be** provided.

NOTE: Warranty tags (ADC Part No. 450064) are available at “no charge” from ADC upon request.

3. The company returning the part(s) must clearly note the complete company name and address on the outside of the package.
4. **ALL** returns **must be** properly packaged to insure that they are not damaged in transit. *Damage claims are the responsibility of the shipper.*

IMPORTANT: No replacements, credits, or refunds **will be** issued for merchandise damaged in transit.

5. **ALL** returns **should be** shipped to the ADC factory in such a manner that they are insured and a proof of delivery can be obtained by the sender.
6. **Shipping charges are not the responsibility of ADC. ALL returns should be “prepaid” to the factory. Any “C.O.D.” or “COLLECT” returns will not be accepted.**

IMPORTANT: No replacements, credits, or refunds **will be** issued if the claim **cannot** be processed due to insufficient information. The party filing the claim **will be** notified in writing, either by “FAX” or “CERTIFIED MAIL - Return Receipt Requested,” as to the information necessary to process claim. If reply **is not** received by the ADC Warranty Department within thirty (30) days from the FAX/letter date, then no replacements, credits, or refunds **will be** issued, and the merchandise **will be** discarded.

SECTION VI

ROUTINE MAINTENANCE

A. CLEANING

A program and/or schedule **should be** established for periodic inspection, cleaning, and removal of lint from various areas of the dryer, as well as throughout the ductwork system. The frequency of cleaning can best be determined from experience at each location. Maximum operating efficiency is dependent upon proper air circulation. The accumulation of lint can restrict this airflow. If the guidelines in this section are met, an ADC dryer will provide many years of efficient, trouble free, and most importantly, safe operation.

WARNING: LINT FROM MOST FABRICS IS HIGHLY COMBUSTIBLE. THE ACCUMULATION OF LINT CAN CREATE A POTENTIAL FIRE HAZARD.

WARNING: KEEP DRYER AREA CLEAR AND FREE FROM COMBUSTIBLE MATERIALS, GASOLINE, AND OTHER FLAMMABLE VAPORS AND LIQUIDS.

NOTE: Suggested time intervals shown are for average usage which is considered six (6) to eight (8) operational (running) hours per day.

IMPORTANT: Dryer produces combustible lint and *must be* exhausted to the outdoors. Every 6 months, inspect the exhaust ducting and remove any lint build up.

SUGGESTED CLEANING SCHEDULE

EVERY THIRD OR FOURTH LOAD

Clean the lint screen every third or fourth load. A clogged lint screen will cause poor dryer performance. The lint screen is located behind the lint door in the base of the dryer. Open the lint door, brush the lint off the lint screen, and remove the lint. Inspect lint screen and replace if torn.

NOTE: The frequency of cleaning the lint screen can best be determined from experience at each location.

WEEKLY

Clean lint accumulation from lint chamber, thermostat, and microprocessor temperature sensor (sensor bracket) area.

WARNING: TO AVOID THE HAZARD OF ELECTRICAL SHOCK, DISCONTINUE ELECTRICAL SUPPLY TO THE DRYER.

90 DAYS

Inspect and remove lint accumulation in customer furnished exhaust ductwork system from dryer's internal exhaust ducting.

WARNING: THE ACCUMULATION OF LINT IN THE EXHAUST DUCTWORK CAN CREATE A POTENTIAL FIRE HAZARD.

WARNING: *DO NOT* OBSTRUCT THE FLOW OF COMBUSTION AND VENTILATION AIR.

WARNING: INSPECT AND REMOVE ANY LINT ACCUMULATION, WHICH CAN CAUSE THE BACK DRAFT DAMPER TO BIND OR STICK.

NOTE: A back draft damper that is sticking partially closed can result in slow drying and shutdown of heat circuit safety switches or thermostats.

NOTE: When cleaning the dryer cabinets, avoid using harsh abrasives. A product intended for the cleaning of appliances is recommended.

B. ADJUSTMENTS

7 DAYS AFTER INSTALLATION AND EVERY 6 MONTHS THEREAFTER

Inspect bolts, nuts, screws, (bearing setscrews), grounding connections, and nonpermanent gas connections (unions, shutoff valves, and orifices). Motor and drive belts **should be** examined. Cracked or seriously frayed belts **should be** replaced. Tighten loose V-belts when necessary. Complete operational check of controls and valves. Complete operational check of **ALL** safety devices (door switches, lint drawer switch, sail switch, burner, and hi-limit thermostats).

C. LUBRICATION

The motor bearings, idler bearings, and under normal/most conditions the basket (tumbler) bearings are permanently lubricated. It is physically possible to relubricate the basket (tumbler) bearings if you choose to do so even though this practice is not necessary. Use Shell Alvania #2 or its equivalent. The basket (tumbler) bearings used in the dryer **DO NOT** have a grease fitting. Provisions are made in the bearing housing for the addition of a grease fitting which can be obtained elsewhere, or from **ADC** by ordering kit Part No. 882159, which includes two (2) fittings.

SECTION VII

DATA LABEL INFORMATION

A. DATA LABEL

Contact **American Dryer Corporation**

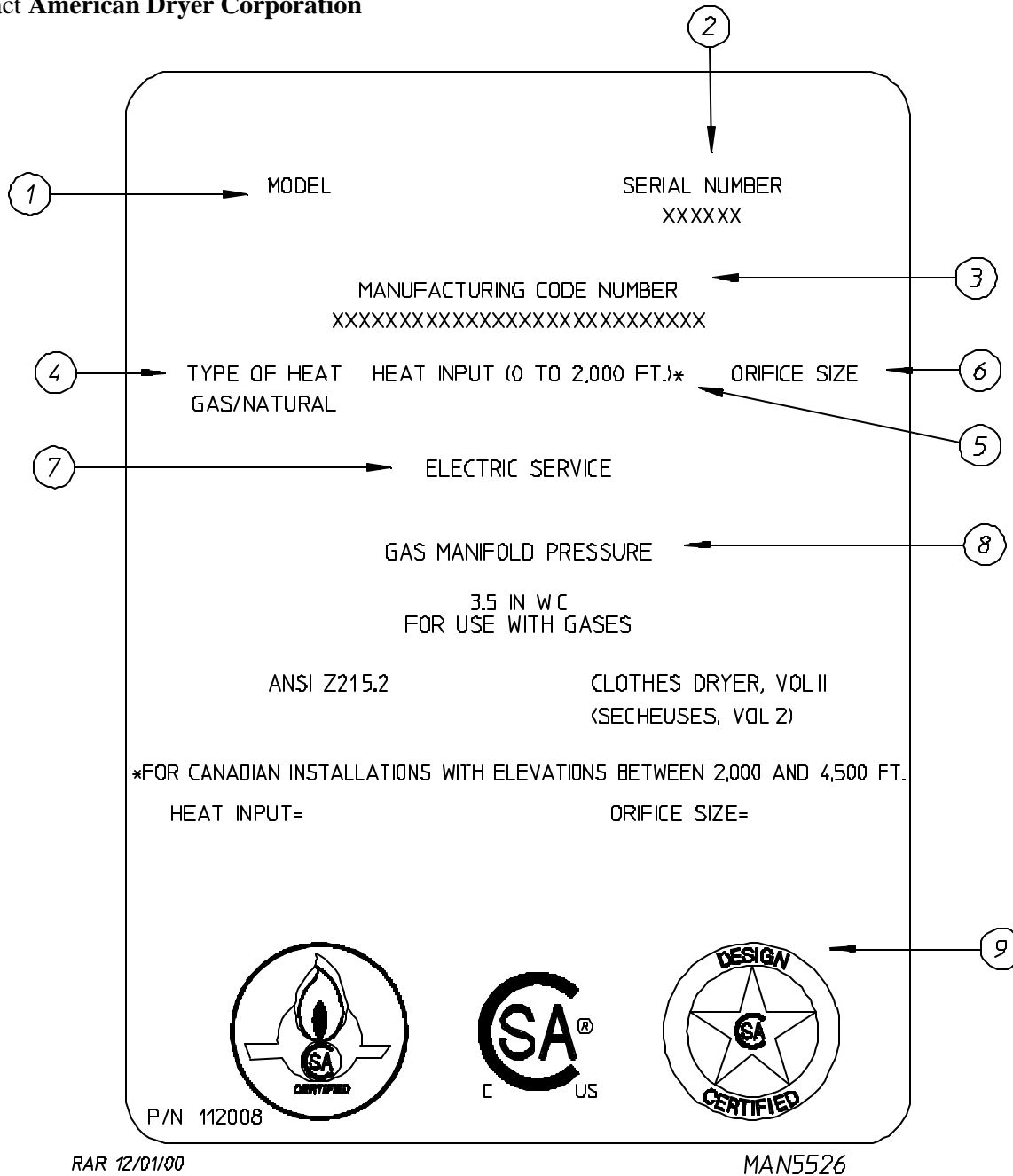

When contacting **American Dryer Corporation**, certain information is required to insure proper service/parts information from **ADC**. This information is on the data label that is affixed to either the backside of the upper control door or left side panel/wall area behind the control door. When contacting **ADC**, please have the **model number** and **serial number** available.

THE DATA LABEL

1. MODEL NUMBER

The model number is an **ADC** number, which describes the size of the dryer and the type of heat (gas, electric, or steam).

2. SERIAL NUMBER

The serial number allows **ADC** to gather information on your particular dryer.

3. MANUFACTURING CODE NUMBER

The manufacturing code number is a number issued by **ADC**, which describes **ALL** possible options on your particular model.

4. TYPE OF HEAT

This describes the type of heat for your particular dryer: gas (either natural gas or liquid propane [L.P.] gas) or steam.

5. HEAT INPUT (for GAS DRYERS)

This describes the heat input in British Thermal Units per Hour (BTUH).

6. ORIFICE SIZE (for GAS DRYERS)

Gives the number drill size used.

7. ELECTRIC SERVICE

This describes the electric service for your particular model.

8. GAS MANIFOLD PRESSURE (for GAS DRYERS)

This describes the manifold pressure taken at the gas valve tap.

9. APPLICABLE APPROVAL SEAL(S)

I.E., Canadian Standards Association International.

SECTION VIII

PROCEDURE FOR FUNCTIONAL CHECK OF REPLACEMENT COMPONENTS

1. Microprocessor Controller (Computer) Board

a. Phase 7 Coin Models

- 1) Upon completing installation of the replacement microprocessor controller (computer) board, reestablish power to the dryer.
- 2) Start the drying cycle by pressing any temperature selection keys (HI, LO, PP).

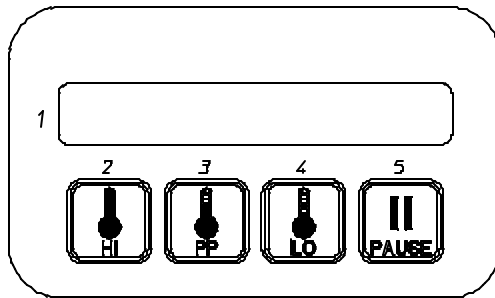

MAN6219

JM 8/1/02

- 3) Verify that the applicable indicator lights on the microprocessor controller (computer) board are lit. (Refer to the **illustration below.**)

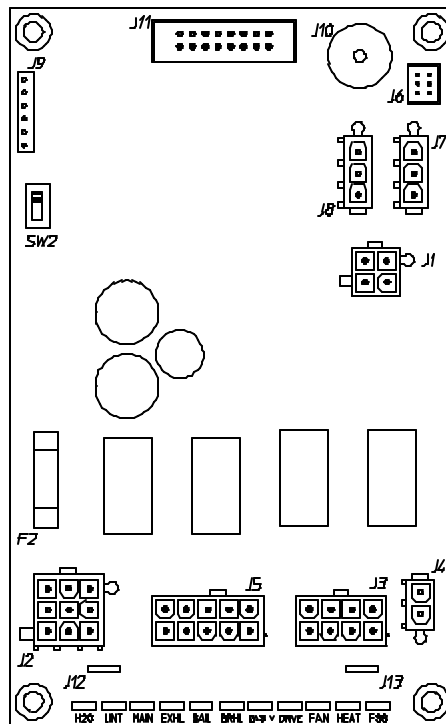

MAN6220

JM 8/1/02

b. Phase 7 Non-coin (OPL) Microprocessor Controller (computer) Models

- 1) Upon completing installation of the replacement microprocessor controller (computer) board, reestablish power to the dryer.
- 2) Start the drying cycle by pressing any of the preset cycles in letters A-F.

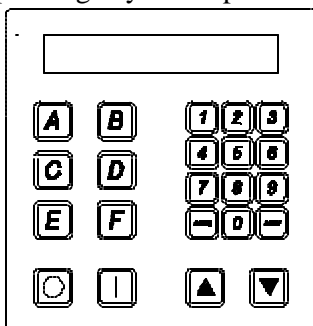

- 3) Verify that the applicable indicator lights on the microprocessor controller (computer) board are lit. (Refer to the **illustration below.**)

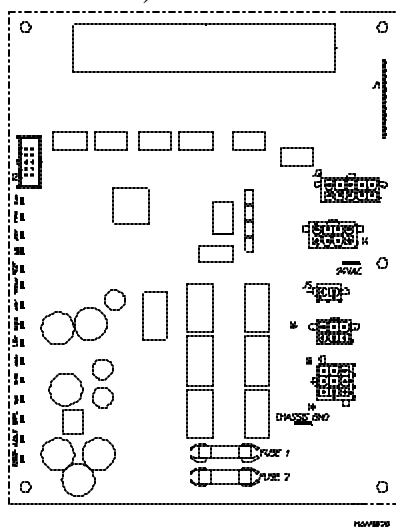

2. For Models With Johnson Controls Direct Spark Ignition (DSI) Module (G760)

Theory Of Operation:

Start the drying cycle. When the gas burner ignites within the chosen trial for ignition time (6-seconds), the flame sensor detects gas burner flame and signals the DSI module to keep the gas valve open...as long as there is a call for heat. The DSI module will "LOCKOUT" if the gas burner flame is not sensed at the end of the trial for ignition period. The trial for ignition period will be repeated for a total of three (3) retries/trials (the initial try and two [2] more retries/trials). If the flame is not sensed at the end of the third retry/trial (inter-purge period of 30-seconds) the DSI module will "LOCKOUT" (light emitting diode [L.E.D.] flashes).

A steady L.E.D. indicator indicates normal operation.

No L.E.D. indicator indicates a power or an internal failure has occurred.

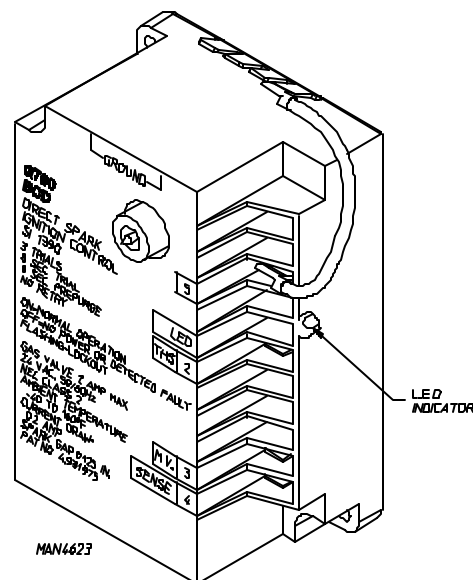

SECTION IX
OPL SENSOR ACTIVATED
FIRE EXTINGUISHING (S.A.F.E.) SYSTEM

S.A.F.E. System In Action



The exclusive Sensor Activated Fire Extinguishing (S.A.F.E.) System will extinguish fires that may start in the drying basket (tumbler). A series of sensors positioned throughout the basket (tumbler) and interfaced with the microprocessor will trigger the S.A.F.E. system water jet(s) to quickly extinguish the flames. The water jet(s) remain on for 2 minutes and will automatically activate again if a fire condition remains or reignites. While the water jet(s) are activated, the basket (tumbler) will jog to move the water throughout the load. The microprocessor will display that the system was activated and will continue to display until the dryer is attended to.

We have tried to make this manual as complete as possible and hope you will find it useful. **ADC** reserves the right to make changes from time to time, without notice or obligation, in prices, specifications, colors, and material, and to change or discontinue models.

BEFORE YOU START!

CHECK LOCAL CODES AND PERMITS

Call your local water company or the proper municipal authority for information regarding local codes.

IMPORTANT: It is your responsibility to have ALL plumbing connections made by a qualified professional to assure that the plumbing installation is adequate and conforms to local, state, and federal regulations or codes.

IMPORTANT: It is the installation or owners responsibility to see that the necessary or required water, water pressure, pipe size, or connections are provided. Manufacturer assumes no responsibility if the Sensor Activated Fire Extinguishing (S.A.F.E.) System **is not** connected, installed, or maintained properly.

INSTALLATION

1. Requirements

The connection point to the electric water solenoid valve is a 1/2" M.P.T., the S.A.F.E. system **must be** supplied with a minimum water pipe size of 1/2" and be provided with 40 PSI +/- 20 PSI (2.75 bar +/- 1.37 bar) of pressure. For use of optional manual bypass, a second source with the same piping and pressure requirements is required.

Flexible 1/2 feeds **must be** provided to avoid damage to electric water solenoid valve by vibration.

IMPORTANT: Flexible supply line/coupling **must be** used. Solenoid valve failure due to hard plumbing connections WILL VOID WARRANTY.

If the rear area of the dryer, or the water supply is located in an area where it will be exposed to cold/freezing temperatures, provisions **must be** made to protect these water lines from freezing.

WARNING: If the water in the supply line or water solenoid valve freezes, the S.A.F.E. system **will be** INOPERATIVE!!

IMPORTANT: Appliance is to be connected to the water mains using a new hose-set and the old hose-sets **should not be** reused.

2. Water Connections:

The water connection is made to the 1/2" M.P.T. bushing of the electric water solenoid valve located at the rear upper left area of the dryer (see photo). The water solenoid valve has a 3/8" M.P.T. connection and a 1/2" bushing is supplied to provide the minimum 1/2" supply (feed) line. Flexible supply line/coupling **must be** used in effort to avoid damage to electric water solenoid valve.

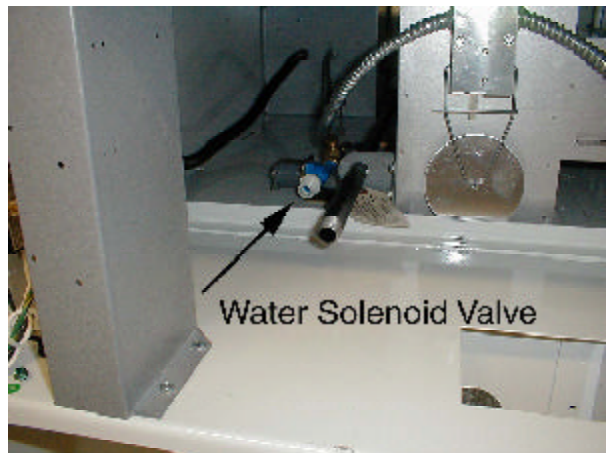

IMPORTANT: Flexible supply line/coupling **must be** used. Solenoid valve failure due to hard plumbing connections **WILL VOID WARRANTY**. **It is recommended** that a filter or strainer be installed in the water supply line.

Typical water supply...

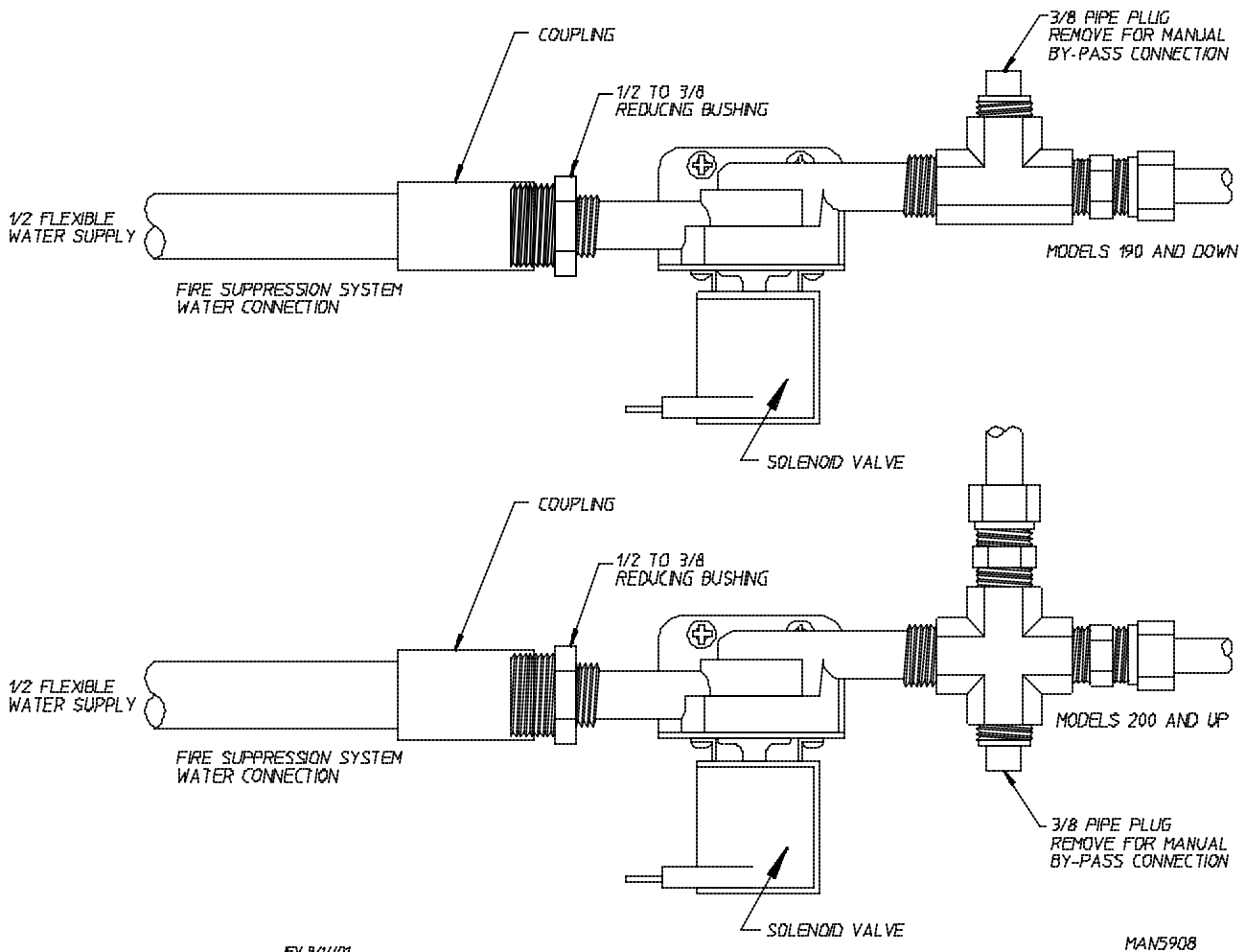

OPTIONAL MANUAL BYPASS

Provisions are made in the dryer sensor activated fire extinguishing (S.A.F.E.) system for the installation of an optional manual bypass. Depending on the model dryer, the connections for the manual bypass are made at the “T” or “four way” fitting located in the outlet supply side of the water solenoid valve. The use and connections of this manual bypass are at the option or discretion of the owner.

The water connection for the manual bypass is made to the “T” or “four way” fitting which has a 3/8” F.P.T. and a coupling **must be** used to provide the minimum 1/2” supply (feed) line.

If the rear area of the dryer, or the water supply is located in an area where it will be exposed to cold/freezing temperatures, provisions **must be** made to protect these water lines from freezing.

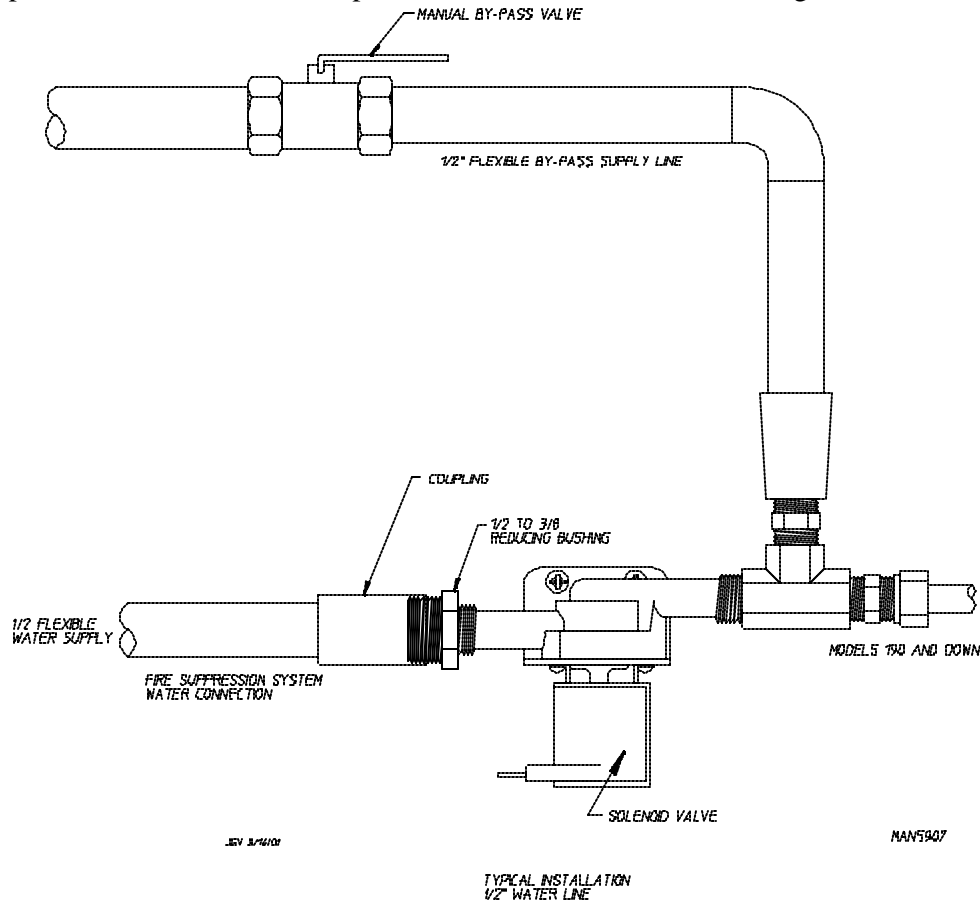

WARNING: If the water in the supply line or water solenoid valve freezes, the S.A.F.E. system **will be** INOPERATIVE!!

The manual ball cock shutoff valve **must be** located outside of the dryer at a distance from the dryer where it is easily accessible.

3. Electrical Requirements

No independent external power source or supply connection is necessary. The 24 volt power to operate the S.A.F.E. system is accomplished internally in the dryer (from the dryer controls).

WARNING: Electrical power **must be** provided to the dryer at **ALL** times. If the main electrical power supply to the dryer is disconnected, the S.A.F.E. system is INOPERATIVE!!

Sensor Activated Fire Extinguishing (S.A.F.E.) System Theory of Operation

While the dryer is in an idle state or 20-seconds after the heat turns off, the Phase 7 control monitors the S.A.F.E. system probe located in the top of the basket (tumbler) chamber and records the minimum temperature. If the minimum recorded S.A.F.E. system probe temperature is no less than 120° F (48° C) and the control detects a 50° rise in temperature, this will be the trip point and the S.A.F.E. system routine will activate.

While a drying cycle is in process and the heat has turned on at least once, the Phase 7 control monitors the exhaust temperature transducer. If the drying cycle temperature set point is set greater than 160° F (71° C) and the control detects an exhaust temperature rise 25° F greater than set point, this will be the trip point and the S.A.F.E. system routine will activate. If set point is below 160° F (71° C) the trip point will be 185° F (85° C).

Once the S.A.F.E. system routine is activated, water will be injected into the basket (tumbler) chamber. Anytime water is being injected into the basket (tumbler); the basket (tumbler) drive will turn the load for 1-second every 15-seconds. This process will continue for a minimum of 2 minutes. After 2 minutes has elapsed, the control will check if the temperature remained above trip point, if so water will remain on. The control will continue to check if temperature is above trip point every 30-seconds. If the water has been on for a constant 10 minutes, the water will be turned off regardless of the temperature. If the temperature has dropped below trip point, the control will turn off the water prior to 10 minutes.

SYSTEM RESET

After the microprocessor determines that the situation is under control and shuts the water being injected into the basket (tumbler) off, the microprocessor display will read “S.A.F.E. System activated,” and the horn/tone will sound until reset manually.

To reset the microprocessor once the control displays “S.A.F.E. System activated,” press the red  key on the keyboard (touch pad).

OPL S.A.F.E. SYSTEM CHECK PROCEDURE

The operation of the water solenoid valve can be tested to insure that the water supply system and valve are functional. Before attempting system check, be sure that **ALL** water supply shutoff valves to the dryer are in the OPEN position, and the dryer **must be** in the “READY” mode where no cycle is loaded or in progress.

The procedure is as follows:

1. Press and hold the RED STOP key (while in “READY” mode and no cycle in progress).
2. Press and hold the “A” key.
3. Water valve will open and water will be dispensed into basket (tumbler) area as long as both keys are held.

IMPORTANT: This is a test function only and the keys *should be* held and system activated for only a second or so, otherwise water will accumulate in various places in the dryer.

Sensor Activated Fire Extinguishing (S.A.F.E.) System Parts Break Down

Replacement parts can be obtained from your reseller or the **ADC** factory. When ordering replacement parts from the factory, you can FAX your order to **ADC** at (508) 678-9447 or telephone your order directly to the **ADC** Parts Department at (508) 678-9000. Please specify the dryer model number and serial number in addition to the **description** and **part number**, so that your order is processed accurately and promptly.

The illustrations on the following pages may not depict your particular dryer exactly. The illustrations are composite of the various dryer models. Be sure to check the descriptions of the parts thoroughly before ordering.

We have tried to make this manual as complete as possible and hope you will find it useful. **ADC** reserves the right to make changes from time to time, without notice or obligation, in prices, specifications, colors, and material, and to change or discontinue models.

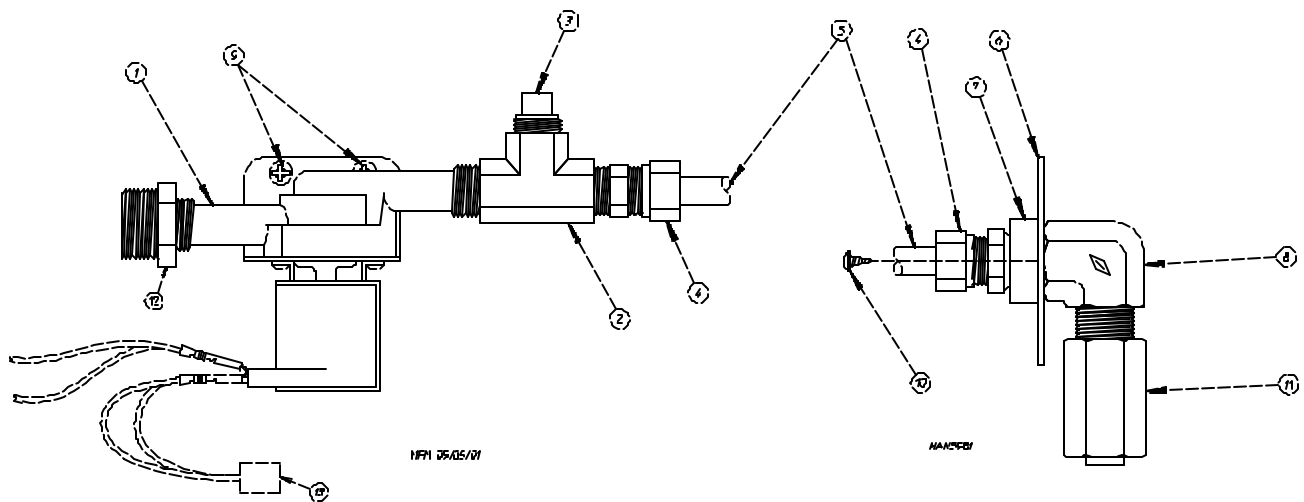

| <u>Illus. No.</u> | <u>Part No.</u> | <u>Qty.</u> | <u>Description</u> |
|-------------------|-----------------|-------------|---|
| 1 | 165114 | 1 | Sensor Activated Fire Extinguishing (S.A.F.E.) System Solenoid Water Valve 24V 50/60 Hz |
| 2 | 143220 | 1 | 3/8" F.P.T. Brass Tee |
| 3 | 143251 | 1 | 3/8" M.P.T. Brass Plug |
| 4 | 143208 | 2 | 3/8" Comp x 3/8" M.P.T. Brass Connector |
| 5 | 143099* | 6' | 3/8" OD x 0.035 Wall Copper Tubing |
| 6 | 311588 | 1 | Sprinkler Head Mounting Plate |
| 7 | 143303 | 1 | 3/8" N.P.T. Brass Lock Nut |
| 8 | 143155 | 1 | 3/8" Brass Elbow 90° |
| 9 | 150430 | 2 | #10 x 1/2" Self Drilling Screw |
| 10 | 150301 | 2 | #8-18 x 7/16" Phillips Pan Head TEK Screw |
| 11 | 143581 | 1 | 3 GPM 3/8" F.P.T. Spray Nozzle |
| 12 | 142888 | 1 | 1/2" to 3/8" Bushing for Sensor Activated Fire Extinguishing (S.A.F.E.) System Valve |
| 13 | 824081 | 1 | R.C. Network Assembly |

* Sold by the foot.

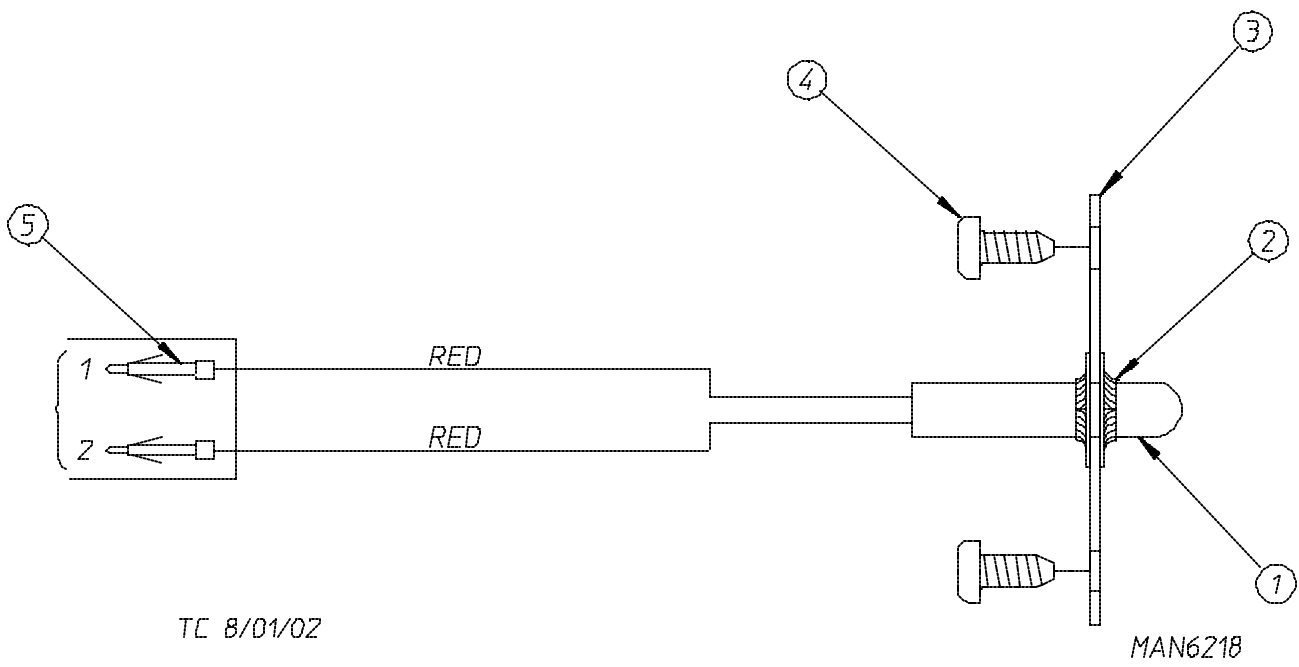

| <u>Illus. No.</u> | <u>Part No.</u> | <u>Qty.</u> | <u>Description</u> |
|-------------------|-----------------|-------------|--|
| 1 | 822752 | 1 | Sensor Activated Fire Extinguishing (S.A.F.E.) System Temperature Probe Assembly (includes illus. nos. 1 through 5) |
| 2 | 154007 | 2 | Push On Fastener |
| 3 | 390390 | 1 | Sensor Bracket ONLY |
| 4 | 150301 | 2 | #8-18 x 7/16" Phillips Pan Head TEK Screw |
| 5 | 122647 | 1 | Connector ONLY (does not include terminals) |

SECTION X

COIN SENSOR ACTIVATED FIRE EXTINGUISHING (S.A.F.E.) SYSTEM (OPTIONAL FOR COIN MODELS)

S.A.F.E. System In Action



The optional exclusive Sensor Activated Fire Extinguishing (S.A.F.E.) system will extinguish fires that may start in the drying basket (tumbler). A series of sensors positioned throughout the basket (tumbler) and interfaced with the microprocessor will trigger the S.A.F.E. water jet(s) to quickly extinguish the flames. The water jet(s) remain on for 2 minutes and will automatically activate again if a fire condition remains or reignites. While the water jet(s) are activated, the basket (tumbler) will jog to move the water throughout the load. The microprocessor will display that the system was activated and will continue to display until the dryer is attended to.

We have tried to make this manual as complete as possible and hope you will find it useful. **ADC** reserves the right to make changes from time to time, without notice or obligation, in prices, specifications, colors, and material, and to change or discontinue models.

BEFORE YOU START!

CHECK LOCAL CODES AND PERMITS

Call your local water company or the proper municipal authority for information regarding local codes.

IMPORTANT: It is your responsibility to have ALL plumbing connections made by a qualified professional to assure that the plumbing installation is adequate and conforms to local, state, and federal regulations or codes.

IMPORTANT: It is the installation or owners responsibility to see that the necessary or required water, water pressure, pipe size, or connections are provided. Manufacturer assumes no responsibility if the sensor activated fire extinguishing (S.A.F.E.) system **is not** connected, installed, or maintained properly.

INSTALLATION

1. Requirements

The inlet water connection to the dryer is a 1/2" M.P.T., the S.A.F.E. system **must be** supplied with a minimum water pipe size of 1/2-inch and be provided with 40 PSI +/- 20 PSI (2.75 bar +/- 1.37 bar) of pressure. For use of optional manual bypass, a second source with the same piping and pressure requirements is required.

Flexible 1/2 feeds **must be** provided to avoid damage to electric water solenoid valve by vibration.

IMPORTANT: Flexible supply line/coupling **must be** used. Solenoid valve failure due to hard plumbing connections WILL VOID WARRANTY.

If the rear area of the dryer, or the water supply is located in an area where it will be exposed to cold/freezing temperatures, provisions **must be** made to protect these water lines from freezing.

WARNING: If the water in the supply line or water solenoid valve freezes, the S.A.F.E. system will be INOPERATIVE!!

IMPORTANT: Appliance is to be connected to the water mains using a new hose-set and the old hose-sets **should not be** reused.

2. Water Connections:

The water connection is made to the 1/2" M.P.T. bushing of the electric water solenoid valve located either at the rear upper left area of the dryer or the rear middle right area on 320/330 models (see photo). The water solenoid valve has a 3/8" M.P.T. connection and a 1/2" bushing is supplied to provide the minimum 1/2-inch supply (feed) line. Flexible supply line/coupling **must be** used in an effort to avoid damaging the electric water solenoid valve.



IMPORTANT: Flexible supply line/coupling *must be* used. Solenoid valve failure due to hard plumbing connections WILL VOID WARRANTY. **It is recommended** that a filter or strainer be installed in the water supply line.

Typical water supply...

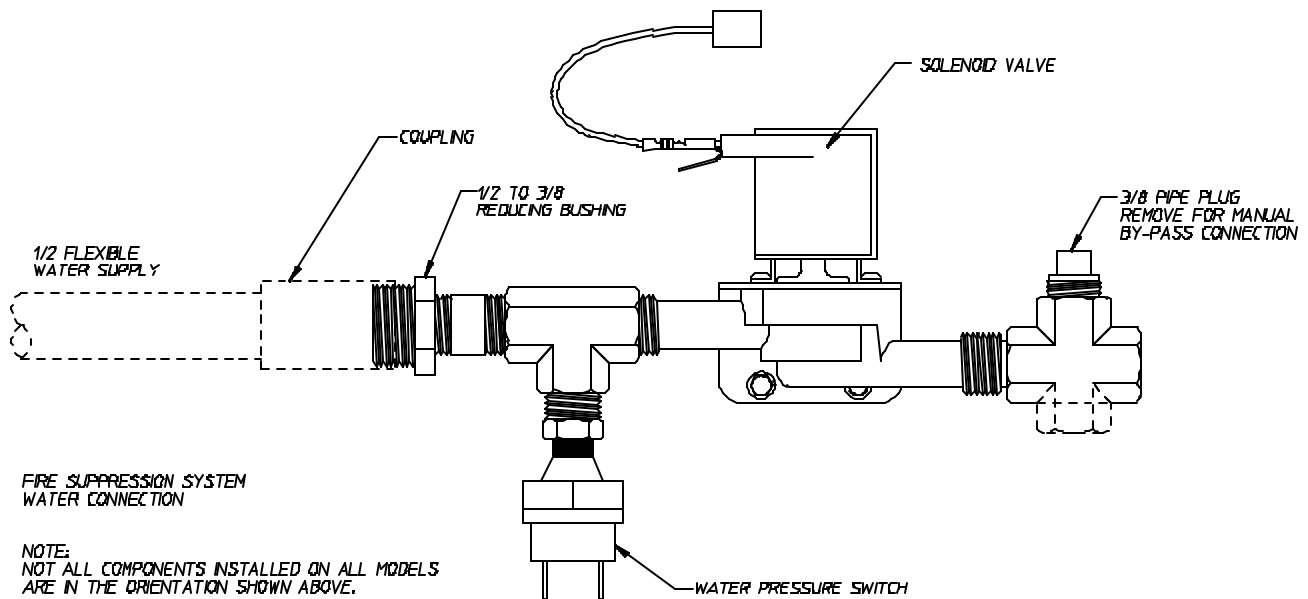

EL 8/12/02

MAN6241

OPTIONAL MANUAL BYPASS

Provisions are made in the dryer sensor activated fire extinguishing (S.A.F.E.) system for the installation of an optional manual bypass. Depending on the model dryer, the connections for the manual bypass are made at the “T” or “cross” fitting located in the outlet side of the water solenoid valve. The use and connections of this manual bypass are at the option or discretion of the owner.

The water connection for the manual bypass is made to the “T” or “cross” fitting which has a 3/8” F.P.T. and a coupling **must be** used to provide the minimum 1/2-inch supply (feed) line.

If the rear area of the dryer, or the water supply is located in an area where it will be exposed to cold/freezing temperatures, provisions **must be** made to protect these water lines from freezing.

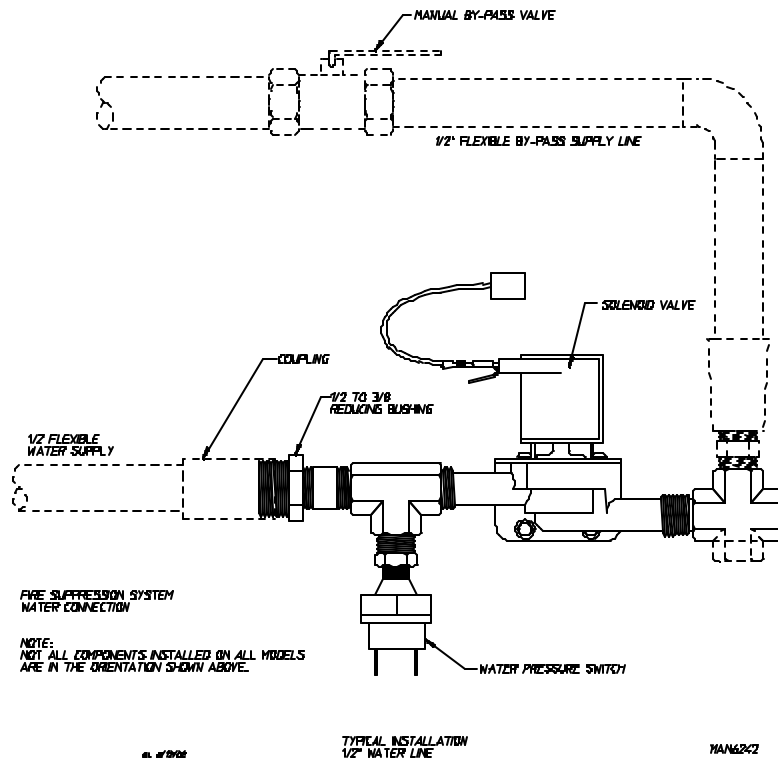

WARNING: If the water in the supply line or water solenoid valve freezes, the S.A.F.E. system **will be** INOPERATIVE!!

The manual ball cock shutoff valve **must be** located outside of the dryer at a distance from the dryer where it is easily accessible.

3. Electrical Requirements

No independent external power source or supply connection is necessary. The 24 volt power to operate the S.A.F.E. system is supplied internally from the dryer control.

WARNING: Electrical power ***must be*** provided to the dryer at **ALL** times. If the main electrical power supply to the dryer is disconnected, the S.A.F.E. system is INOPERATIVE!!

Sensor Activated Fire Extinguishing (S.A.F.E.) System

Theory of Operation

While the dryer is in an idle state or 20-seconds after the heat turns off, the Phase 7 control monitors the S.A.F.E. system probe located in the top of the basket (tumbler) chamber and records the minimum temperature. If the minimum recorded S.A.F.E. system probe temperature is greater than 120° F (48° C) and the control detects a 50° rise in temperature, this will be the trip point and the S.A.F.E. system routine will activate.

While a drying cycle is in process and the heat has turned on at least once, the Phase 7 control monitors the exhaust temperature transducer. If the drying cycle temperature set point is set greater than 160° F (71° C) and the control detects an exhaust temperature rise 25° F greater than set point, this will be the trip point and the S.A.F.E. system routine will activate. If set point is below 160° F (71° C) the trip point will be 185° F (85° C).

Once the S.A.F.E. system routine is activated, the control will display “S.A.F.E. System Activated” and water will be injected into the basket (tumbler) chamber. Anytime water is being injected into the basket (tumbler); the basket (tumbler) drive will turn the load for 1-second every 15-seconds. This process will continue for a minimum of 2 minutes. After 2 minutes has elapsed, the control will check if the temperature remained above trip point, if so water will remain on. The control will continue to check if temperature is above trip point every 30-seconds. If the water has been on for a constant 10 minutes, the water will be turned off regardless of the temperature and the control will display “S.A.F.E. Was Activated.” If the temperature has dropped below trip point, the control will turn off the water prior to 10 minutes.

Disabled Sensor Activated Fire Extinguishing (S.A.F.E.) System

In the event that the S.A.F.E. system is not installed properly or if there is a malfunction in the system the Phase 7 coin control will notify the user by displaying the message “S.A.F.E. DISABLED...” If the “PAUSE” and “LO” keys are simultaneously pressed, the control will display one of the following diagnostic messages indicating the fault with the system. If there is more than one issue with the S.A.F.E. system, the control will display one message at a time.

S.A.F.E. Diagnostic Messages

Open S.A.F.E. Probe Fault: This message indicates that the S.A.F.E. probe is either not connected or is damaged.

Shorted S.A.F.E. Probe Fault: This message indicated that the S.A.F.E. probe is damaged or the wiring is shorted.

Open S.A.F.E. Valve Fault: This indicates that the water valve is open or that it is not connected to the control.

Shorted S.A.F.E. Valve Fault: This indicates the water valve is shorted or the wiring to the valve is shorted.

Water Not Connected: This indicates that there is no water pressure at the water valve. This will occur if water is not connected to dryer or if there is low water pressure in the water line coming to the dryer. This could also be a defective pressure switch or wiring to the pressure switch.

SYSTEM RESET

To reset the microprocessor once the control displays “S.A.F.E. Was Activated,” press and hold the “PAUSE” key for 3-seconds.

S.A.F.E. Parts Break Down

Single Pocket Dryers

Replacement parts can be obtained from your reseller or the **ADC** factory. When ordering replacement parts from the factory, you can FAX your order to **ADC** at (508) 678-9447 or telephone your order directly to the **ADC** Parts Department at (508) 678-9000. Please specify the dryer **model number** and **serial number** in addition to the **description** and **part number**, so that your order is processed accurately and promptly.

The illustrations on the following pages may not depict your particular dryer exactly. The illustrations are composite of the various dryer models. Be sure to check the descriptions of the parts thoroughly before ordering.

We have tried to make this manual as complete as possible and hope you will find it useful. **ADC** reserves the right to make changes from time to time, without notice or obligation, in prices, specifications, colors, and material, and to change or discontinue models.

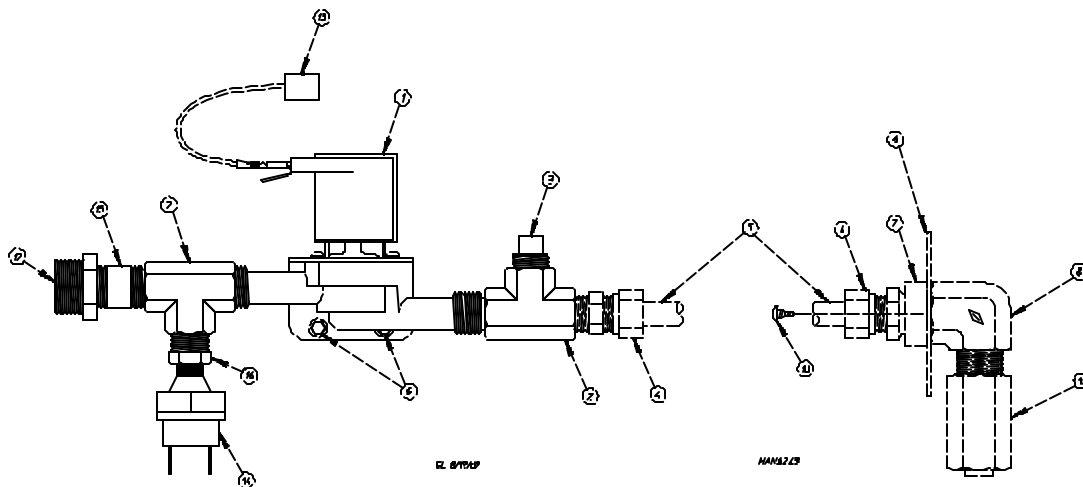

| <u>Illus. No.</u> | <u>Part No.</u> | <u>Qty.</u> | <u>Description</u> |
|-------------------|-----------------|-------------|---|
| 1 | 165114 | 1 | Sensor Activated Fire Extinguishing (S.A.F.E.) System Solenoid Valve 24V 50/60 Hz |
| 2 | 143220 | 2 | 3/8" F.P.T. Brass Tee |
| 3 | 143251 | 1 | 3/8" M.P.T. Brass Plug |
| 4 | 143208 | 2 | 3/8" Comp x 3/8" M.P.T. Brass Connector |
| 5 | 143099* | 6' | 3/8" OD x 0.035 Wall Copper Tubing |
| 6 | 311588 | 1 | Sprinkler Head Mounting Plate |
| 7 | 143303 | 1 | 3/8" N.P.T. Brass Lock Nut |
| 8 | 143155 | 1 | 3/8" Brass Elbow 90° |
| 9 | 150430 | 2 | #10 x 1/2" Self Drilling Screw |
| 10 | 150301 | 2 | #8-18 x 7/16" Phillips Pan Head TEK Screw |
| 11 | 143581 | 1 | 3 GPM 3/8" F.P.T. Spray Nozzle |
| 12 | 142888 | 1 | 1/2" to 3/8" Sensor Activated Fire Extinguishing (S.A.F.E.) System Valve |
| 13 | 824081 | 1 | R.C. Network Assembly |
| 14 | 136987 | 1 | Water Pressure Switch |
| 15 | 143241 | 1 | 3/8" N.P.T. Close Brass Nipple |
| 16 | 143315 | 1 | 3/8" M.P.T. x 1/8" F.P.T. Brass Bushing |

* Sold by the foot.

S.A.F.E. Parts Break Down

AD-320 & 330 Stack Dryers

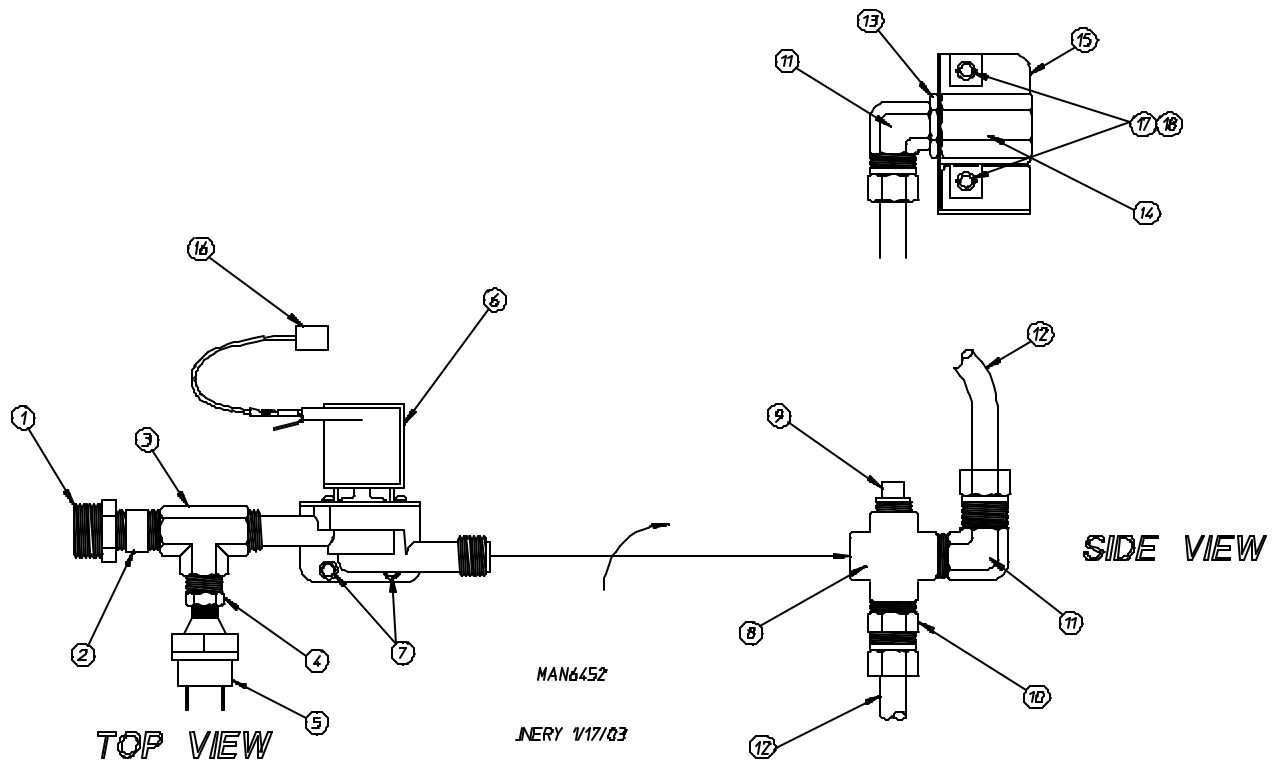

| <u>Illus. No.</u> | <u>Part No.</u> | <u>Qty.</u> | <u>Description</u> |
|-------------------|-----------------|-------------|---|
| 1 | 142888 | 1 | 1/2" M.P.T. x 3/8" F.P.T. Hex Bushing |
| 2 | 143241 | 1 | 3/8" Close Bracket Nipple |
| 3 | 143220 | 1 | 3/8" F.P.T. Brass Tee |
| 4 | 143315 | 1 | 3/8" M.P.T. x 1/8" F.P.T. Brass Bushing |
| 5 | 136987 | 1 | Water Jet Pressure Switch |
| 6 | 165114 | 1 | S.A.F.E. Solenoid Valve 24V 50/60 |
| 7 | 150309 | 2 | #10-16 x 1/2" Hex Head TEK Crimptite Screw |
| 8 | 143236 | 1 | 3/8" Brass Cross |
| 9 | 143251 | 1 | 3/8" M.P.T. Brass Plug |
| 10 | 143208 | 1 | 3/8" Comp x 3/8" M.P.T. Brass Connect |
| 11 | 143320 | 3 | 3/8" Comp x 3/8" M.P.T. Brass Elbow |
| 12 | 143099* | 4' | 3/8" OD x 0.03 Wall Copper Tubing |
| 13 | 143303 | 2 | 3/8" N.P.T. Brass Lock Nut |
| 14 | 143585 | 2 | 3 GPM 3/8" F.P.T. 60 D.E.G. Spray Nozzle |
| 15 | 311591 | 2 | Sprinkler Head Mounting Bracket |
| 16 | 824081 | 1 | R.C. Network Assembly |
| 17 | 154001 | 4 | #10-24 Speed Nut |
| 18 | 150207 | 4 | #10-24 x 1/2" Phillips Pan Head Machine Screw |

* Sold by the foot.

S.A.F.E. Sensor Probe Assembly - All Models

(2 required for 2-pocket stack dryers)

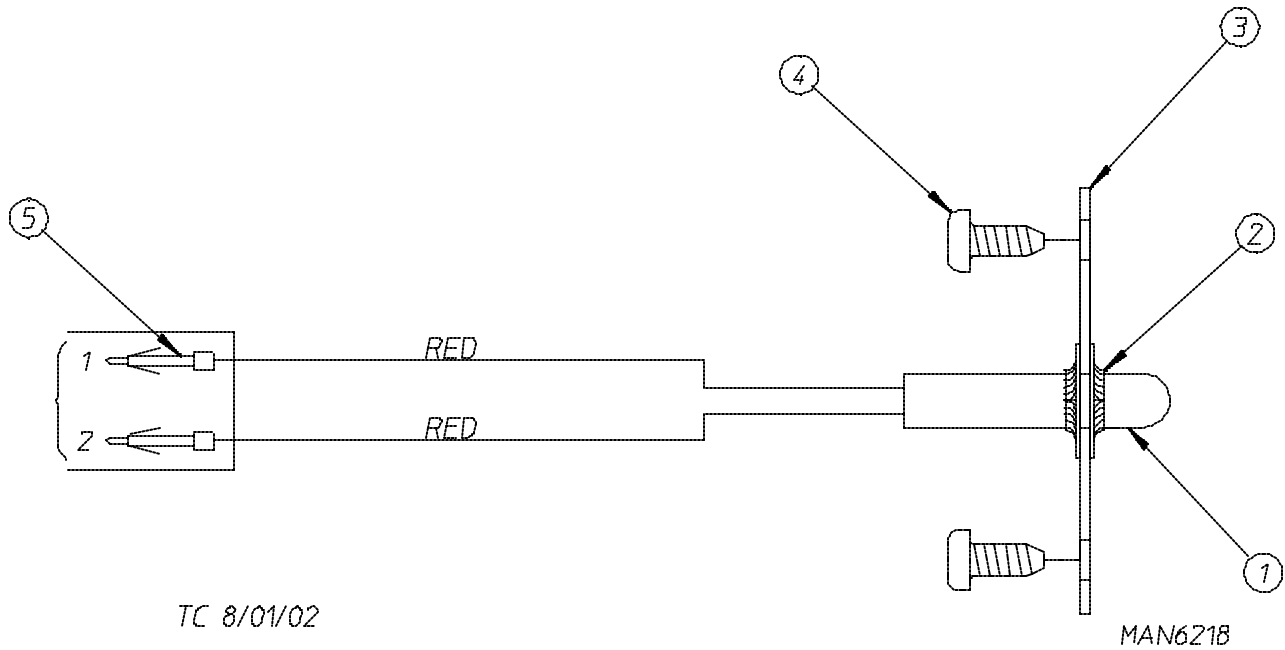

| <u>Illus. No.</u> | <u>Part No.</u> | <u>Qty.</u> | <u>Description</u> |
|-------------------|-----------------|-------------|--|
| 1 | 822752 | 1 | Sensor Activated Fire Extinguishing (S.A.F.E.) System Temperature Probe Assembly (includes illus. nos. 1 through 5) |
| 2 | 154007 | 2 | Push On Fastener |
| 3 | 390390 | 1 | Sensor Bracket ONLY |
| 4 | 150301 | 2 | #8-18 x 7/16" Phillips Pan Head TEK Screw |
| 5 | 122647 | 1 | Connector ONLY (does not include terminals) |

