

# AD/ML-310 Installation Manual

## Phase 7

**WARNING:** For your safety the information in this manual must be followed to minimize the risk of fire or explosion and to prevent property damage, personal injury or death.

— Do not store or use gasoline or other flammable vapors and liquids in the vicinity of this or any other appliance.

— **WHAT TO DO IF YOU SMELL GAS:**

- Do not try to light any appliance.
- Do not touch any electrical switch; do not use any phone in your building.
- Clear the room, building or area of all occupants.
- Immediately call your gas supplier from a neighbor's phone. Follow the gas supplier's instructions.
- If you cannot reach your gas supplier, call the fire department.

— Installation and service must be performed by a qualified installer, service agency or the gas supplier.

**AVERTISSEMENT:** Assurez-vous de bien suivre les instructions données dans cette notice pour réduire au minimum le risque d'incendie ou d'explosion ou pour éviter tout dommage matériel, toute blessure ou la mort.

— Ne pas entreposer ni utiliser d'essence ni d'autres vapeurs ou liquides inflammables à proximité de cet appareil ou de tout autre appareil.

— **QUE FAIRE SI VOUS SENTEZ UNE ODEUR DE GAZ:**

- Ne pas tenter d'allumer d'appareils.
- Ne touchez à aucun interrupteur. Ne pas vous servir des téléphones se trouvant dans le bâtiment.
- Évacuez la pièce, le bâtiment ou la zone.
- Appelez immédiatement votre fournisseur de gaz depuis un voisin. Suivez les instructions du fournisseur.
- Si vous ne pouvez rejoindre le fournisseur de gaz, appelez le service des incendies.

— L'installation et l'entretien doivent être assurés par un installateur ou un service d'entretien qualifié ou par le fournisseur de gaz.



### American Dryer Corporation

88 Currant Road

Fall River MA 02720-4781 USA

Telephone: +1 (508) 678-9000 / Fax: +1 (508) 678-9447

e-mail: techsupport@amdry.com

[www.adclaundry.com](http://www.adclaundry.com)

# Retain This Manual in a Safe Place for Future Reference

This product embodies advanced concepts in engineering, design, and safety. If this product is properly maintained, it will provide many years of safe, efficient, and trouble free operation.

**Only qualified technicians should service this equipment.**

**OBSERVE ALL SAFETY PRECAUTIONS** displayed on the equipment or specified in the installation manual included with the dryer.

The following “**FOR YOUR SAFETY**” caution must be posted near the dryer in a prominent location.

**FOR YOUR SAFETY**

Do not store or use gasoline or other flammable vapors and liquids in the vicinity of this or any other appliance.

**POUR VOTRE SÉCURITÉ**

Ne pas entreposer ni utiliser d'essence ni d'autres vapeurs ou liquides inflammables à proximité de cet appareil ou de tout autre appareil.

We have tried to make this manual as complete as possible and hope you will find it useful. The manufacturer reserves the right to make changes from time to time, without notice or obligation, in prices, specifications, colors, and material, and to change or discontinue models. The illustrations included in this manual may not depict your particular dryer exactly.

## IMPORTANT

For your convenience, log the following information:

DATE OF PURCHASE \_\_\_\_\_ MODEL NO. \_\_\_\_\_

RESELLER'S NAME \_\_\_\_\_

Serial Number(s) \_\_\_\_\_

Replacement parts can be obtained from your reseller or the ADC factory. When ordering replacement parts from the factory, you can FAX your order to ADC at +1 (508) 678-9447 or telephone your order directly to the ADC Parts Department at +1 (508) 678-9000. Please specify the dryer model number and serial number in addition to the description and part number, so that your order is processed accurately and promptly.

These instructions are only valid if the following country code is on the appliance... If this code is not present on the appliance, it is necessary to refer to the technical instructions which will provide the necessary information concerning the modification of the appliance to the condition of use for the country.

In accordance with EN ISO 3166-1, the names of countries shall be represented by the following codes:

**GB** United Kingdom

**IE** Ireland

**“IMPORTANT NOTE TO PURCHASER”**

Information must be obtained from your local gas supplier on the instructions to be followed if the user smells gas. These instructions must be posted in a prominent location near the dryer.

# **⚠ WARNING**

## **Proposition 65**

Use of this product could expose you to substances from fuel combustion that contain chemicals known to the State of California to cause cancer, birth defects and other reproductive harm.

## **IMPORTANT**

You must disconnect and lockout the electric supply and the gas supply or the steam supply before any covers or guards are removed from the machine to allow access for cleaning, adjusting, installation, or testing of any equipment per OSHA standards.

Please observe all safety precautions displayed on the equipment and/or specified in the installation manual included with the dryer.

## **CAUTION**

Dryer(s) should never be left unattended while in operation.

“Caution: Label all wires prior to disconnection when servicing controls. Wiring errors can cause improper operation.”

«Attention: Lor des opérations d’entretien des commandes étiqueter tous fils avant de les déconnecter. Toute erreur de câblage peut être une source de danger et de panne.»

## **WARNING**

Children should not be allowed to play on or near the dryer(s). Children should be supervised if near dryer(s) in operation.

Under no circumstances should the dryer door switch(es), lint door/drawer switch(es), or heat safety circuit(s) ever be disabled.

Do not modify this appliance.

The dryer must never be operated with any of the back guards, outer tops, or service panels removed. Personal injury or fire could result.

The dryer must never be operated without the lint filter/screen in place, even if an external lint collection system is used.

## **FOR YOUR SAFETY**

Do not dry mop heads in the dryer. Do not use dryer in the presence of dry cleaning fumes.

The dryers must not be installed or stored in an area where it will be exposed to water and/or weather.

The wiring diagram for the dryer is located in the front electrical control box area.

In the State of Massachusetts, the following installation instructions apply:

- Installations and repairs must be performed by a qualified or licensed contractor, plumber, or gasfitter qualified or licensed by the State of Massachusetts.
- If using a ball valve, it shall be a T-handle type.
- A flexible gas connector, when used, must not exceed 3 feet.

## **Table of Contents**

|   |           |
|---|-----------|
| <b>SECTION I</b>  |           |
| <b>Safety Precautions .....</b>                                       | <b>4</b>  |
| <b>SECTION II</b>   |           |
| <b>Specifications .....</b>   | <b>7</b>  |
| <b>SECTION III</b>  |           |
| <b>Installation Procedures .....</b>                                  | <b>11</b> |
| A. Reassembly of Dryer .....  | 11        |
| B. Location Requirements .....  | 19        |
| C. Fresh Air Supply Requirements .....                                | 20        |
| D. Exhaust Requirements .....   | 21        |
| E. Compressed Air Supply System .....                                 | 24        |
| F. Electrical Information .....                                       | 28        |
| G. Gas Information .....  | 31        |
| H. Steam Information .....  | 35        |
| I. Preoperational Test .....  | 37        |
| J. Preparation for Operation / Start-Up .....                         | 39        |
| K. Shut Down Instructions .....                                       | 40        |
| <b>SECTION IV</b>   |           |
| <b>Service / Parts Information .....</b>                              | <b>41</b> |
| A. Service .....  | 41        |
| B. Parts .....  | 41        |
| <b>SECTION V</b>  |           |
| <b>Warranty Information .....</b>                                     | <b>42</b> |
| A. Returning Warranty Cards .....                                     | 42        |
| B. Warranty .....   | 42        |
| C. Returning Warranty Parts .....                                     | 42        |
| <b>SECTION VI</b>   |           |
| <b>Routine Maintenance .....</b>                                      | <b>44</b> |
| A. Cleaning .....   | 44        |
| B. Adjustments .....  | 46        |
| C. Lubrication .....  | 46        |
| <b>SECTION VII</b>  |           |
| <b>Manual Reset Burner Hi-Limit Instructions .....</b>                | <b>47</b> |
| <b>SECTION VIII</b>   |           |
| <b>Data Label Information .....</b>                                   | <b>48</b> |
| <b>SECTION IX</b>   |           |
| <b>Procedure for Functional Check of Replacement Components .....</b> | <b>49</b> |
| <b>SECTION X</b>  |           |
| <b>Suppression System .....</b>                                       | <b>50</b> |

# SECTION I

## SAFETY PRECAUTIONS

**WARNING:** For your safety, the information in this manual *must be* followed to minimize the risk of fire or explosion or to prevent property damage, personal injury, or loss of life.

**WARNING:** The dryer *must never be* operated with any of the back guards, outer tops, or service panels removed. **PERSONAL INJURY OR FIRE COULD RESULT.**

1. **DO NOT** store or use gasoline or other flammable vapors and liquids in the vicinity of this or any other appliance.
2. **DO NOT** spray aerosols in the vicinity of this appliance while it is in operation.
3. Purchaser/user should consult the local gas supplier for proper instructions to be followed in the event the user smells gas. The instructions **should be** posted in a prominent location.
4. WHAT TO DO IF YOU SMELL GAS:
  - a. **DO NOT** try to light any appliance.
  - b. **DO NOT** touch any electrical switch.
  - c. **DO NOT** use any phone in your building.
  - d. Clear the room, building, or area of **ALL** occupants.
  - e. Immediately call your gas supplier from a neighbor's phone. Follow the gas supplier's instructions.
  - f. If you **cannot** reach your gas supplier, call the fire department.
5. Installation and service **must be** performed by a qualified installer, service agency, or gas supplier.
6. Dryer(s) **must be** exhausted to the outdoors.
7. Although **ADC** produces a very versatile dryer, there are some articles that, due to fabric composition or cleaning method, **should not be** dried in it.

**WARNING:** Dry only water washed fabrics. **DO NOT** dry articles spotted or washed in dry cleaning solvents, a combustible detergent, industrial chemicals, or "all purpose" cleaner. **EXPLOSION COULD RESULT.**

**WARNING:** **DO NOT** dry rags or articles coated or contaminated with gasoline, kerosene, oil, paint, or wax. **EXPLOSION COULD RESULT.**

**IMPORTANT:** Dryer *must be* installed in a location/environment, which the ambient temperature remains between 40° F (4.44° C) and 130° F (54.44° C).

**WARNING:** *DO NOT* dry mop heads. Contamination by wax or flammable solvents will create a fire hazard.

**WARNING:** *DO NOT* use heat for drying articles that contain plastic, foam, sponge rubber, or similarly textured rubber materials. Drying in a heated basket (tumbler) may damage plastics or rubber and may be a fire hazard.

8. The possible presence of residual quantities of aggressive or decomposed chemicals in the load may produce damage to the machine and harmful fumes.
9. A program **should be** established for the inspection and cleaning of lint in the heating unit area, exhaust ductwork, and inside the dryer. The frequency of inspection and cleaning can best be determined from experience at each location.

**WARNING:** The collection of lint in the burner area and exhaust ductwork can create a potential fire hazard.

10. For personal safety, the dryer **must be** electrically grounded in accordance with local codes and/or the National Electrical Code ANSI/NFPA NO. 70-LATEST EDITION or in Canada, the Canadian Electrical Codes Parts 1 & 2 CSA C22.1-1990 or LATEST EDITION.

**NOTE:** Failure to electrically ground the dryer properly will VOID THE WARRANTY.

11. **UNDER NO CIRCUMSTANCES** should the dryer door switch, lint drawer switch, or heat safety circuits ever be disabled.

**WARNING: PERSONAL INJURY OR FIRE COULD RESULT** should the dryer door switch, lint drawer switch, or heat safety circuits ever be disabled.

12. This dryer is not to be used in the presence of dry cleaning solvents or fumes.
13. Remove articles from the dryer as soon as the drying cycle has been completed.

**WARNING:** Articles left in the dryer after the drying and cooling cycles have been completed can create a fire hazard.

14. **DO NOT** operate steam dryers with more than 125 psi (8.61 bar) steam pressure. Excessive steam pressure can damage steam coil and/or harm personnel.
15. Replace leaking flexible hoses or other steam fixtures immediately. **DO NOT** operate the dryer with leaking flexible hoses. **PERSONAL INJURY OR FIRE COULD RESULT**.
16. **READ AND FOLLOW ALL CAUTION AND DIRECTION LABELS ATTACHED TO THE DRYER.**
17. For safety, proper operation, and optimum performance, the dryer **must not be** operated with a load less than sixty-six percent (66%), 204 lb (92.53 kg) of its rated capacity.



# SECTION II

## SPECIFICATIONS

|  |  |                                       |                              |
|--|--|---------------------------------------|------------------------------|
| MAXIMUM CAPACITY (DRY WEIGHT)                  |  | 310 lb                                | <b>140.61 kg</b>             |
| MINIMUM LOAD SIZE                              |  | 205 lb                                | <b>92.99 kg</b>              |
| TUMBLER DIAMETER                               |  | 62-1/2"                               | <b>158.75 cm</b>             |
| TUMBLER DEPTH                                  |  | 60"                                   | <b>152.40 cm</b>             |
| TUMBLER VOLUME                                 |  | 106.50 cu ft                          | <b>3015.744 L</b>            |
| DOOR OPENING (WIDTH X HEIGHT)                  |  | 36-3/4" x 43"                         | <b>93.35 cm x 109.22 cm</b>  |
| DOOR SILL HEIGHT, LEVEL                        |  | 36-1/2"                               | <b>92.71 cm</b>              |
| DOOR SILL HEIGHT, REAR TILT                    |  | 53"                                   | <b>134.62 cm</b>             |
| DOOR SILL HEIGHT, FRONT TILT                   |  | 33-1/2"                               | <b>85.09 cm</b>              |
| CABINET OPERATING DEPTH, LEVEL (1 DOOR/2 DOOR) |  | 72-3/4" / 78"                         | <b>184.79 cm / 198.12 cm</b> |
| CABINET WIDTH                                  |  | 82-1/2"                               | <b>209.55 cm</b>             |
| REAR TILT                                      |  | 15°                                   |                              |
| FRONT TILT                                     |  | 15°                                   |                              |
| WATER CONNECTION                               |  | 3/4" F.N.P.T.                         |                              |
| <b>GAS</b>                                     | CABINET REAR TILT HEIGHT                 | 122-7/16"                             | <b>310.99 cm</b>             |
|  | CABINET OPERATING HEIGHT, LEVEL          | 114-1/4"                              | <b>290.20 cm</b>             |
|  | CABINET FULL TILT DEPTH                  | 116-7/16"                             | <b>295.75 cm</b>             |
|  | APPROX. NET WEIGHT                       | 5,000 lb                              | <b>2,267.96 kg</b>           |
|  | APPROX. SHIPPING WEIGHT                  | 5,310 lb                              | <b>2,408.58 kg</b>           |
|  | VOLTAGE AVAILABLE                        | 208-575v 3ø                           | 3,4w 50/60 Hz                |
|  | TUMBLER/DRIVE MOTOR                      | 5 hp                                  | <b>3.73 kW</b>               |
|  | BLOWER/FAN MOTOR (REAR/SIDE EXHAUST)     | 15 hp / 25 hp                         | <b>11.19 kW / 18.64 kW</b>   |
|  | BURNER BLOWER MOTOR                      | N / A                                 |                              |
|  | BURNER TYPE                              | On / Off                              |                              |
|  | HEAT INPUT                               | 1,125,000 Btu/hr                      | <b>283,495 kcal/hr</b>       |
|  | INLET PIPE CONNECTION (NON-TILT/TILT)    | (2) 1-1/2" M.N.P.T. / 1-1/2" M.N.P.T. |                              |
|  | MAXIMUM GAS PRESSURE                     | 12 in WC                              | <b>29.89 mb</b>              |
|  | AIRFLOW                                  | 6,500 cfm                             | <b>184.06 cmm</b>            |
|  | MAXIMUM EXHAUST BACK PRESSURE            | 0.3 in WC                             | <b>0.75 mb</b>               |
|  | EXHAUST DIAMETER                         | 24"                                   | <b>60.96 cm</b>              |
|  | COMPRESSED AIR PRESSURE                  | 80 psi (± 10 psi)                     | <b>5.52 bar (± 0.69 bar)</b> |
| COMPRESSED AIR VOLUME (1-WAY/2-WAY TILT)       | 11 cfh / 11 cfh                          | <b>0.31 cmh / 0.31 cmh</b>            |                              |
| COMPRESSED AIR CONNECTION (NON-TILT/TILT)      | 3/8" F.N.P.T. / 3/8" Quick Connection    |                                       |                              |
| <b>STEAM</b>                                   | CABINET REAR TILT HEIGHT                 | 127-1/2"                              | <b>323.85 cm</b>             |
|  | CABINET OPERATING HEIGHT, LEVEL          | 126-1/2"                              | <b>321.31 cm</b>             |
|  | CABINET FULL TILT DEPTH                  | 113-7/16"                             | <b>288.13 cm</b>             |
|  | APPROX. NET WEIGHT                       | 5,425 lb                              | <b>2,460.74 kg</b>           |
|  | APPROX. SHIPPING WEIGHT                  | 5,735 lb                              | <b>2,601.35 kg</b>           |
|  | VOLTAGE AVAILABLE                        | 208-575v 3ø                           | 3,4w 50/60 Hz                |
|  | TUMBLER/DRIVE MOTOR                      | 5 hp                                  | <b>3.73 kW</b>               |
|  | BLOWER/FAN MOTOR                         | 25 hp                                 | <b>18.64 kW</b>              |
|  | BOILER HORSEPOWER (NORMAL LOAD)          | 35 Bhp                                |                              |
|  | SUPPLY CONNECTION                        | 2" M.N.P.T.                           |                              |
|  | RETURN CONNECTION (NON-TILT/TILT)        | 2" M.N.P.T. / 1-1/4" M.N.P.T.         |                              |
|  | STEAM CONSUMPTION                        | 1,153 lb/hr                           | <b>522.99 kg/hr</b>          |
|  | AIRFLOW                                  | 8,500 cfm                             | <b>240.69 cmm</b>            |
|  | MAXIMUM EXHAUST BACK PRESSURE            | 0.3 in WC                             | <b>0.75 mb</b>               |
|  | EXHAUST DIAMETER                         | 24"                                   | <b>60.96 cm</b>              |
|  | COMPRESSED AIR PRESSURE                  | 80 psi (± 10 psi)                     | <b>5.52 bar (± 0.69 bar)</b> |
|  | COMPRESSED AIR VOLUME (1-WAY/2-WAY TILT) | 11 cfh / 11 cfh                       | <b>0.31 cmh / 0.31 cmh</b>   |
| COMPRESSED AIR CONNECTION (NON-TILT/TILT)      | 3/8" F.N.P.T. / 3/8" Quick Connection    |                                       |                              |

Shaded areas are stated in metric equivalents

9/24/04

**NOTE:** Dryers *must be* provided with a clean, dry, regulated 80 psi +/- 10 psi (5.51 bar +/- 0.68 bar) air supply (equivalent volume = 11 cfh [0.31 cmh]).

**NOTE:** ADC reserves the right to make changes in specifications at any time without notice or obligation.

## 310\* NON-TILT GAS MODEL

\* BOTH GAS AND STEAM TILTING UNITS MUST BE SUPPLIED WITH CLEAN, DRY, REGULATED AIR AT 80 PSI +/- 10 PSI (5.52 BAR +/- 0.62 BAR)  
 \*\* DUCTWORK SIZE VARIES WITH INSTALLATION CONDITIONS. EXHAUST STATIC PRESSURE SHOULD NOT EXCEED 0.3" WATER COLUMN (0.74 mb).  
 \*\*\* SIZE OF PIPING TO DRYER VARIES WITH INSTALLATION CONDITIONS. CONTACT FACTORY FOR ASSISTANCE.  
 \*\*\*\* THE FIRE SUPPRESSION SYSTEM MUST BE SUPPLIED WITH WATER AT A PRESSURE OF 40 PSI MIN/100 PSI MAX. (2.8 BAR MIN/6.9 BAR MAX).

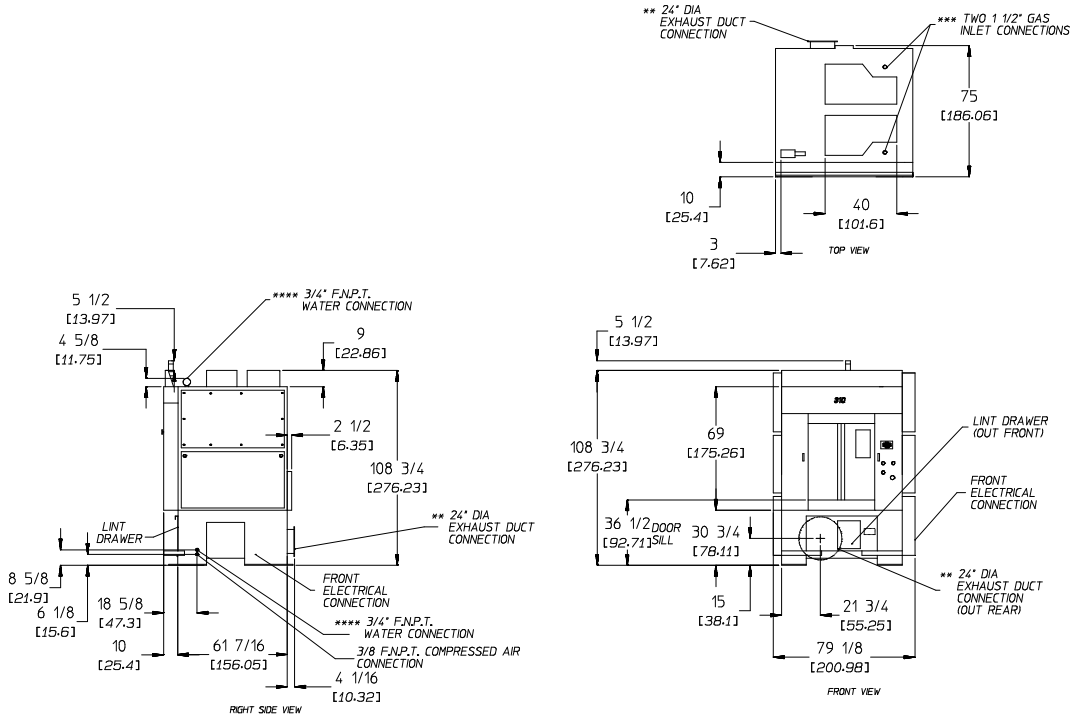

## 310\* NON-TILT STEAM MODEL

\* BOTH GAS AND STEAM TILTING UNITS MUST BE SUPPLIED WITH CLEAN, DRY, REGULATED AIR AT 80 PSI +/- 10 PSI (5.52 BAR +/- 0.62 BAR)  
 \*\* DUCTWORK SIZE VARIES WITH INSTALLATION CONDITIONS. EXHAUST STATIC PRESSURE SHOULD NOT EXCEED 0.3" WATER COLUMN (0.74 mb).  
 \*\*\* SIZE OF PIPING TO DRYER VARIES WITH INSTALLATION CONDITIONS. CONTACT FACTORY FOR ASSISTANCE.  
 \*\*\*\* THE FIRE SUPPRESSION SYSTEM MUST BE SUPPLIED WITH WATER AT A PRESSURE OF 40 PSI MIN/100 PSI MAX. (2.8 BAR MIN/6.9 BAR MAX).

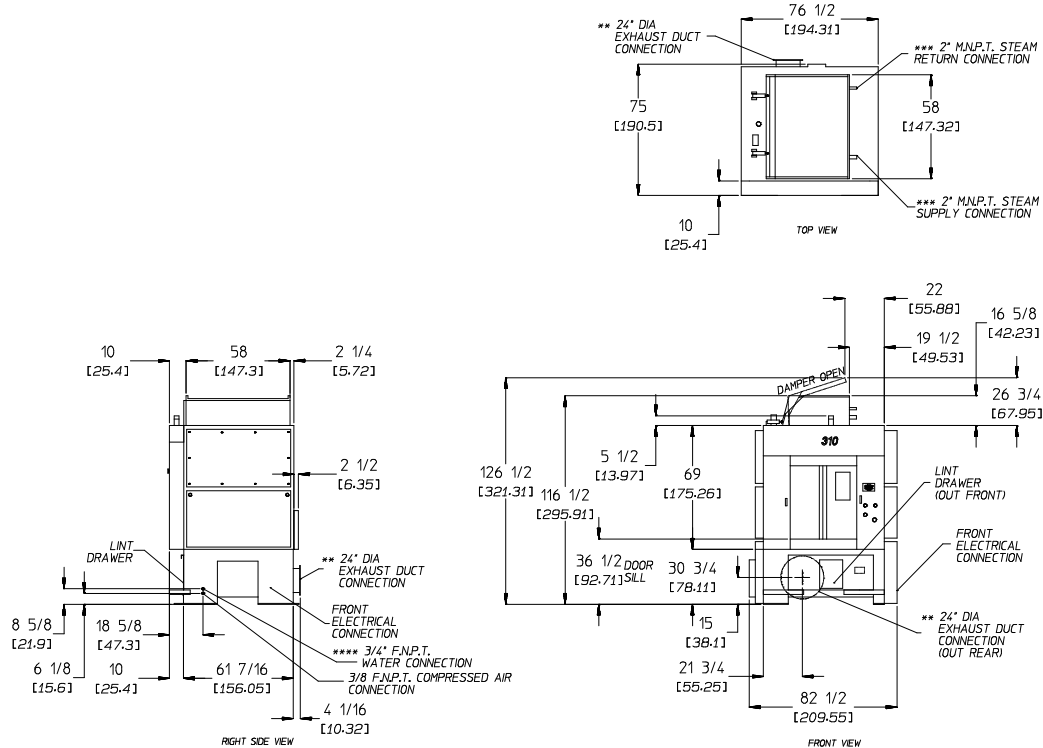

**NOTE:** ADC reserves the right to make changes in specifications at any time without notice or obligation.



### 310 TILTING\* 1 DOOR / FORWARD AND REAR TILT GAS MODEL

- \* BOTH GAS AND STEAM TILTING UNITS MUST BE SUPPLIED WITH CLEAN, DRY, REGULATED AIR AT 80 PSI + 10 PSI (5.52 BAR + .69 BAR)
- \*\* DUCTWORK SIZE VARIES WITH INSTALLATION CONDITIONS. EXHAUST STATIC PRESSURE SHOULD NOT EXCEED 0.3" WATER COLUMN (0.74 mm)
- \*\*\* SIZE OF PIPING TO DRYER VARIES WITH INSTALLATION CONDITIONS. CONTACT FACTORY FOR ASSISTANCE.

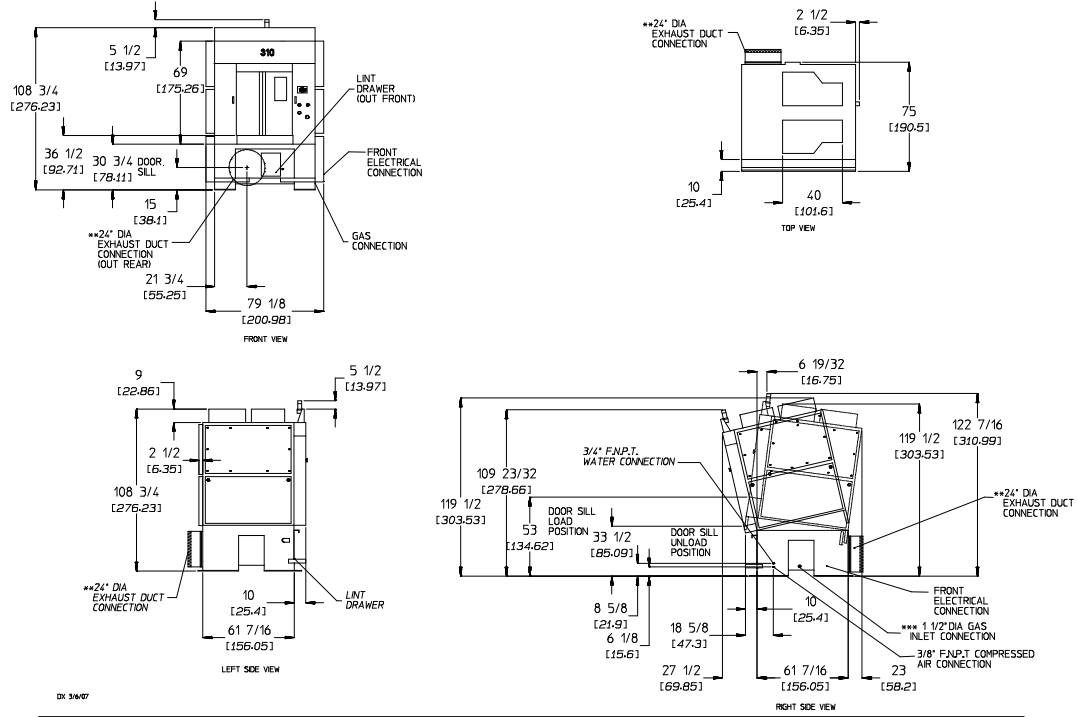

### 310 TILTING\* 1 DOOR / FORWARD AND REAR TILT STEAM MODEL

- \* BOTH GAS AND STEAM TILTING UNITS MUST BE SUPPLIED WITH CLEAN, DRY, REGULATED AIR AT 80 PSI + 10 PSI (5.52 BAR + .69 BAR)
- \*\* DUCTWORK SIZE VARIES WITH INSTALLATION CONDITIONS. EXHAUST STATIC PRESSURE SHOULD NOT EXCEED 0.3" WATER COLUMN (0.74 mm)
- \*\*\* SIZE OF PIPING TO DRYER VARIES WITH INSTALLATION CONDITIONS. CONTACT FACTORY FOR ASSISTANCE.

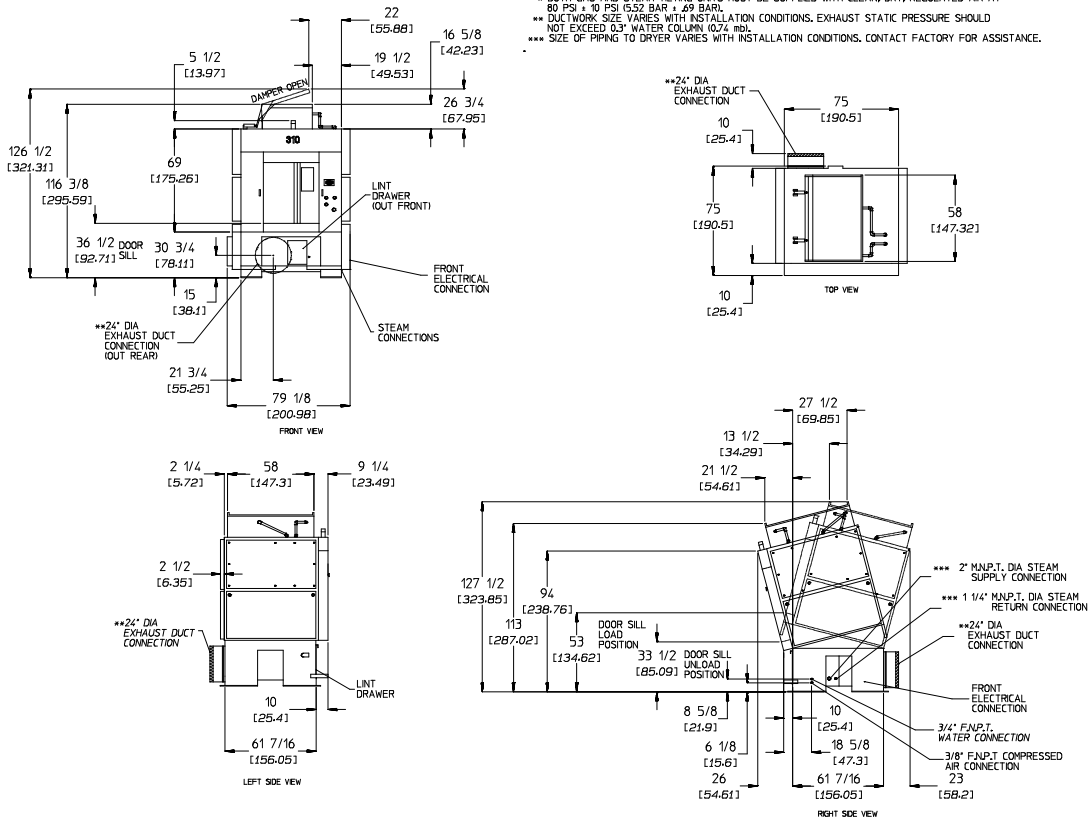

**NOTE:** ADC reserves the right to make changes in specifications at any time without notice or obligation.

## 310 TILTING\* 2 DOOR/REAR TILT GAS MODEL

- \* BOTH GAS AND STEAM TILTING UNITS MUST BE SUPPLIED WITH CLEAN, DRY, REGULATED AIR AT 80 PSI ± 10 PSI (5.52 BAR ± .69 BAR).
- \*\* DUCTWORK SIZE VARIES WITH INSTALLATION CONDITIONS. EXHAUST STATIC PRESSURE SHOULD NOT EXCEED 0.3" WATER COLUMN (0.74 mb).
- \*\*\* SIZE OF PIPING TO DRYER VARIES WITH INSTALLATION CONDITIONS. CONTACT FACTORY FOR ASSISTANCE.

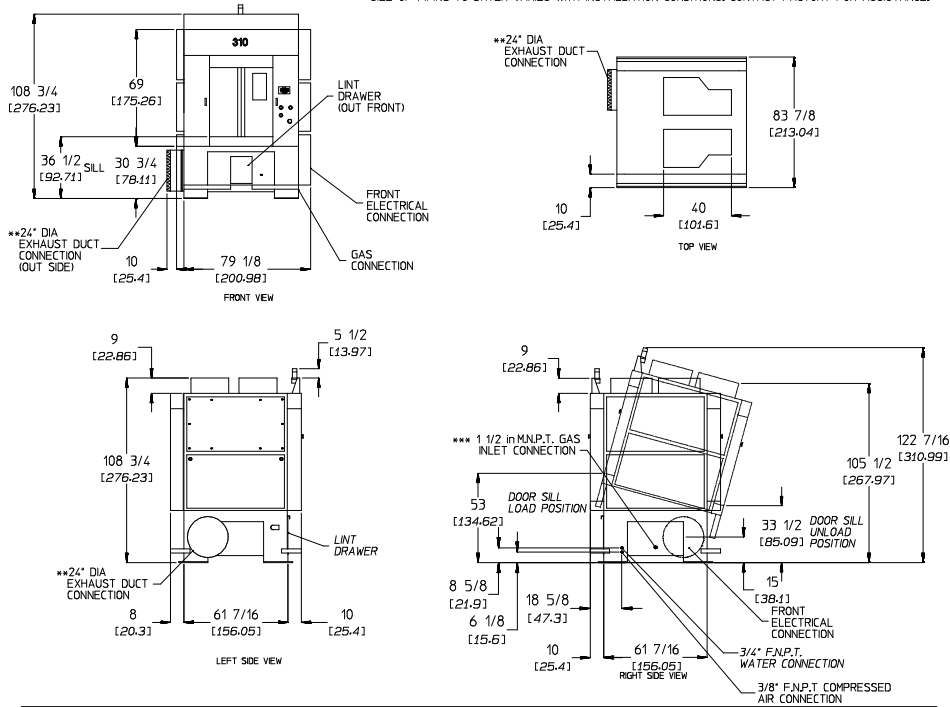

## 310 TILTING\* 2 DOOR/REAR TILT STEAM MODEL

- \* BOTH GAS AND STEAM TILTING UNITS MUST BE SUPPLIED WITH CLEAN, DRY, REGULATED AIR AT 80 PSI ± 10 PSI (5.52 BAR ± .69 BAR).
- \*\* DUCTWORK SIZE VARIES WITH INSTALLATION CONDITIONS. EXHAUST STATIC PRESSURE SHOULD NOT EXCEED 0.3" WATER COLUMN (0.74 mb).
- \*\*\* SIZE OF PIPING TO DRYER VARIES WITH INSTALLATION CONDITIONS. CONTACT FACTORY FOR ASSISTANCE.

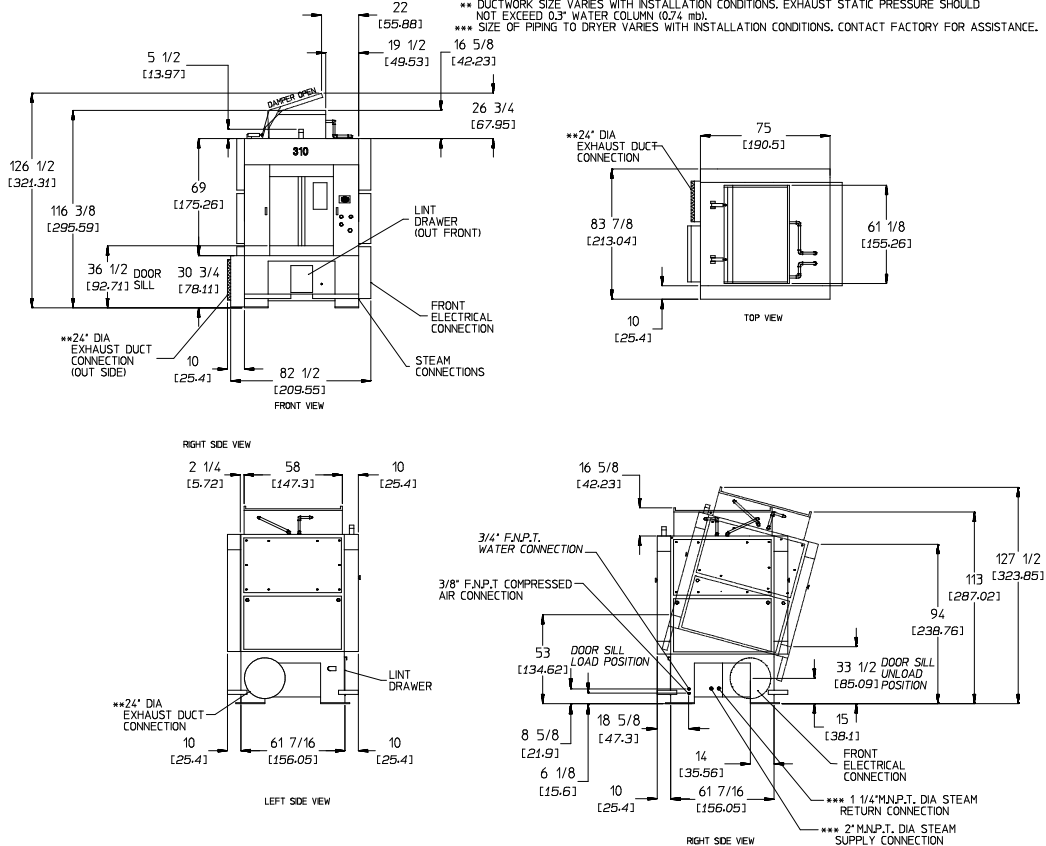

**NOTE:** ADC reserves the right to make changes in specifications at any time without notice or obligation.

# SECTION III

## INSTALLATION PROCEDURES

Installation **should be** performed by competent technicians in accordance with local and state codes. In the absence of these codes, the installation **must conform** to applicable American National Standards: ANSI Z223.1-LATEST EDITION (National Fuel Gas Code) or ANSI/NFPA NO. 70-LATEST EDITION (National Electrical Code) or in Canada, the installation **must conform** to applicable Canadian Standards: CAN/CGA-B149.1-M91 (Natural Gas) or CAN/CGA-B149.2-M91 (Liquid Propane [L.P.] Gas) or LATEST EDITION (for General Installation and Gas Plumbing) or Canadian Electrical Codes Parts 1 & 2 CSA C22.1-1990 or LATEST EDITION (for Electrical Connections).

### A. REASSEMBLY OF DRYER

**IMPORTANT:** Always keep the basket (tumbler) section of the dryer in an upright position when moving it.

**WARNING:** Twisting of the gas line may cause premature failure.

**NOTE:** On a yearly basis flex gas lines **must be** inspected for leaks, if any signs of fraying or abrasion are found, the gas line **must be** replaced.

The dryer may be shipped one (1) of two (2) ways; as a complete unit fully assembled and ready for hookup or with the basket (tumbler) section separated from the base. If the dryer is shipped in two (2) pieces, the basket (tumbler) section will have to be lifted onto the base. Use cables through the eyebolts on top of the basket (tumbler) section, or use a forklift for the lifting process.

The tilting dryer is made in many loading and unloading options. Please refer to the reassembly instructions on the following pages for your particular style of dryer.

If a steam dryer is shipped in two (2) pieces, the steam coil may have been removed from the top of the basket (tumbler) section and shipped with the base. If this is the case, lift the steam coil onto the top of the basket (tumbler) section with the steam pipe connections facing towards the right side of the dryer and bolt the coil to the top of the dryer with the 1/4" hardware supplied. There are three (3) panels that cover the front, right side, and rear of the steam coil. Fasten these in proportion also. Reconnect the steam and condensate pipe unions to the coil. These pipes run down to the flex hoses in the base.

# GAS MODEL / NON-TILT

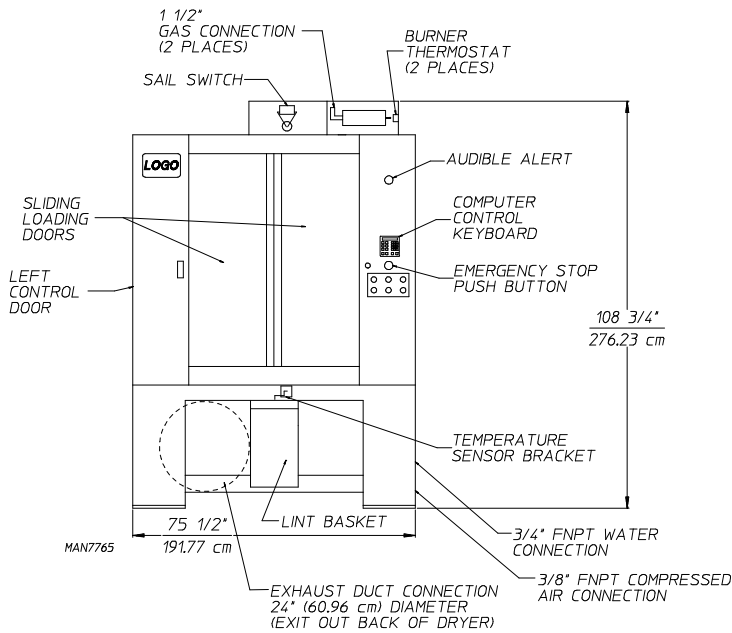

# STEAM MODEL / NON-TILT

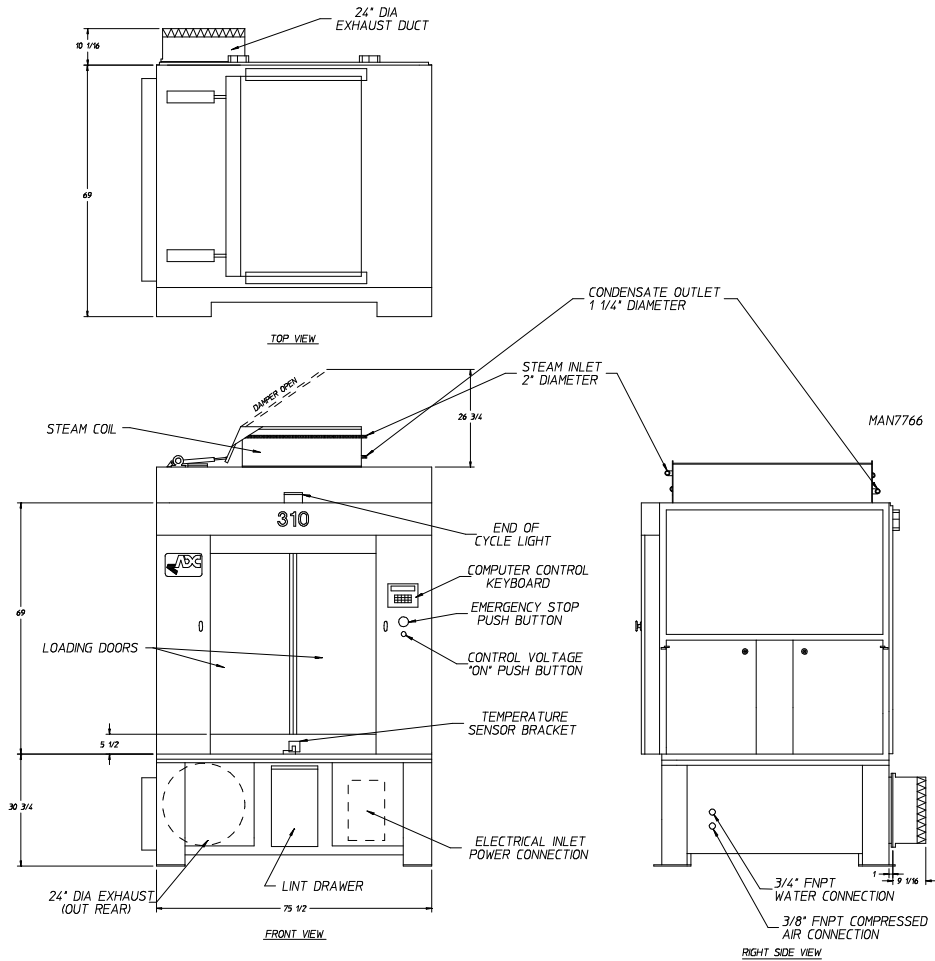

**NOTE:** ADC reserves the right to make changes in specifications at any time without notice or obligation.

# GAS MODEL / 1 DOOR

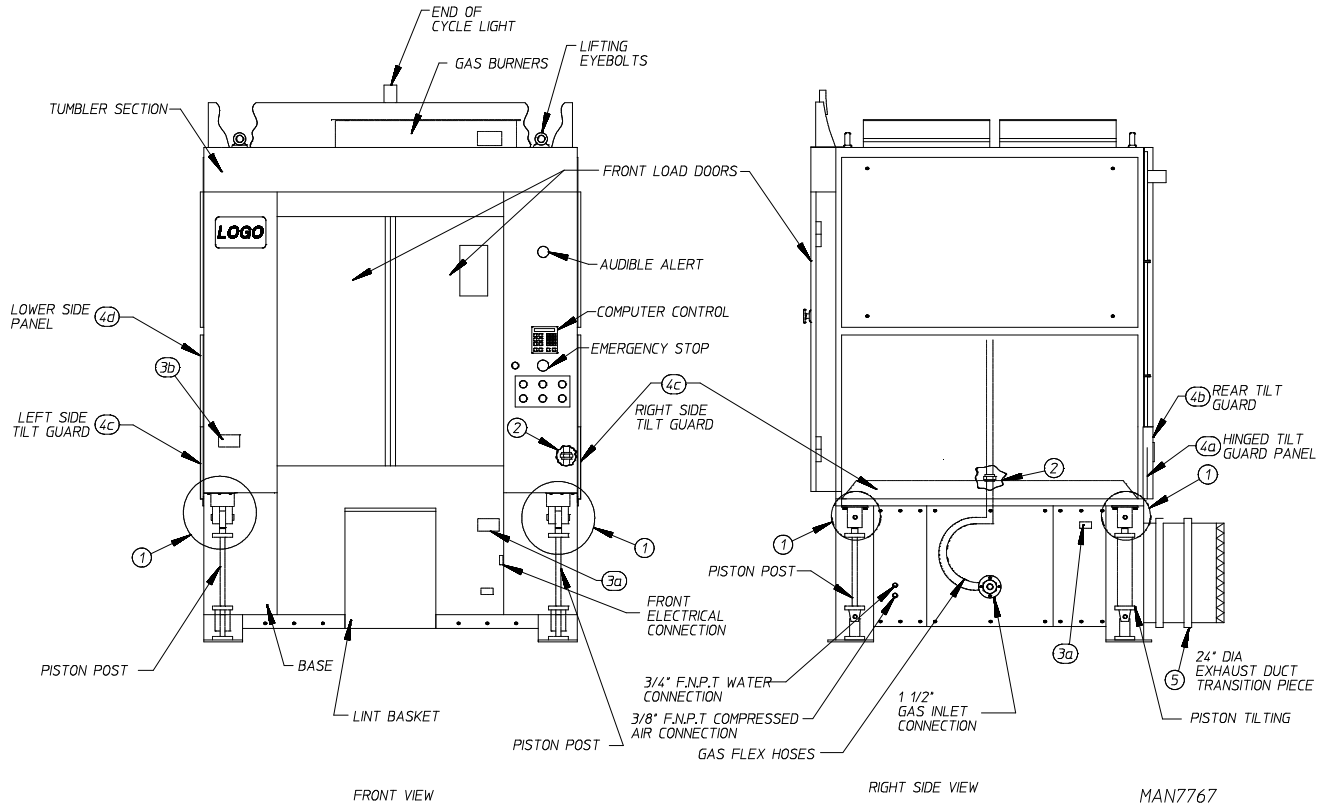

# STEAM MODEL / 1 DOOR

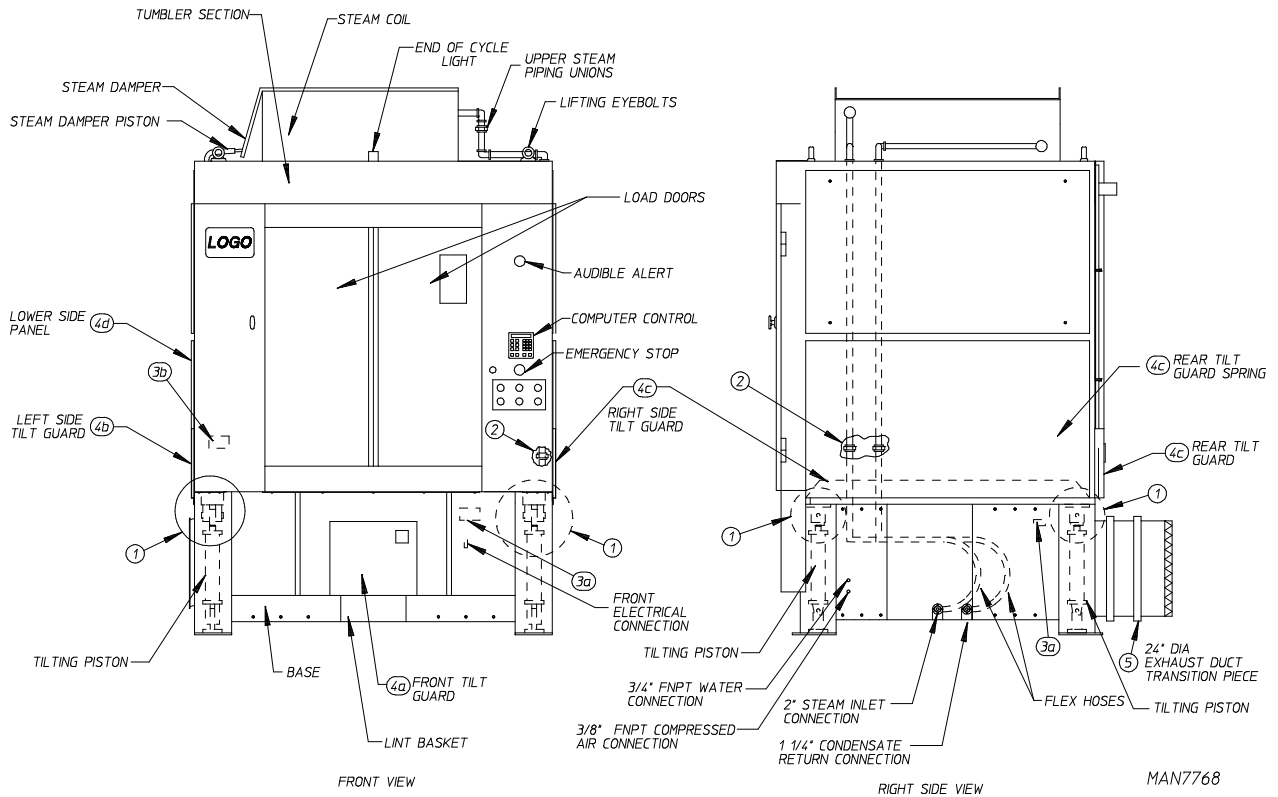

**NOTE:** ADC reserves the right to make changes in specifications at any time without notice or obligation.

# GAS MODEL / 2 DOOR / REAR TILT (PASS THRU)

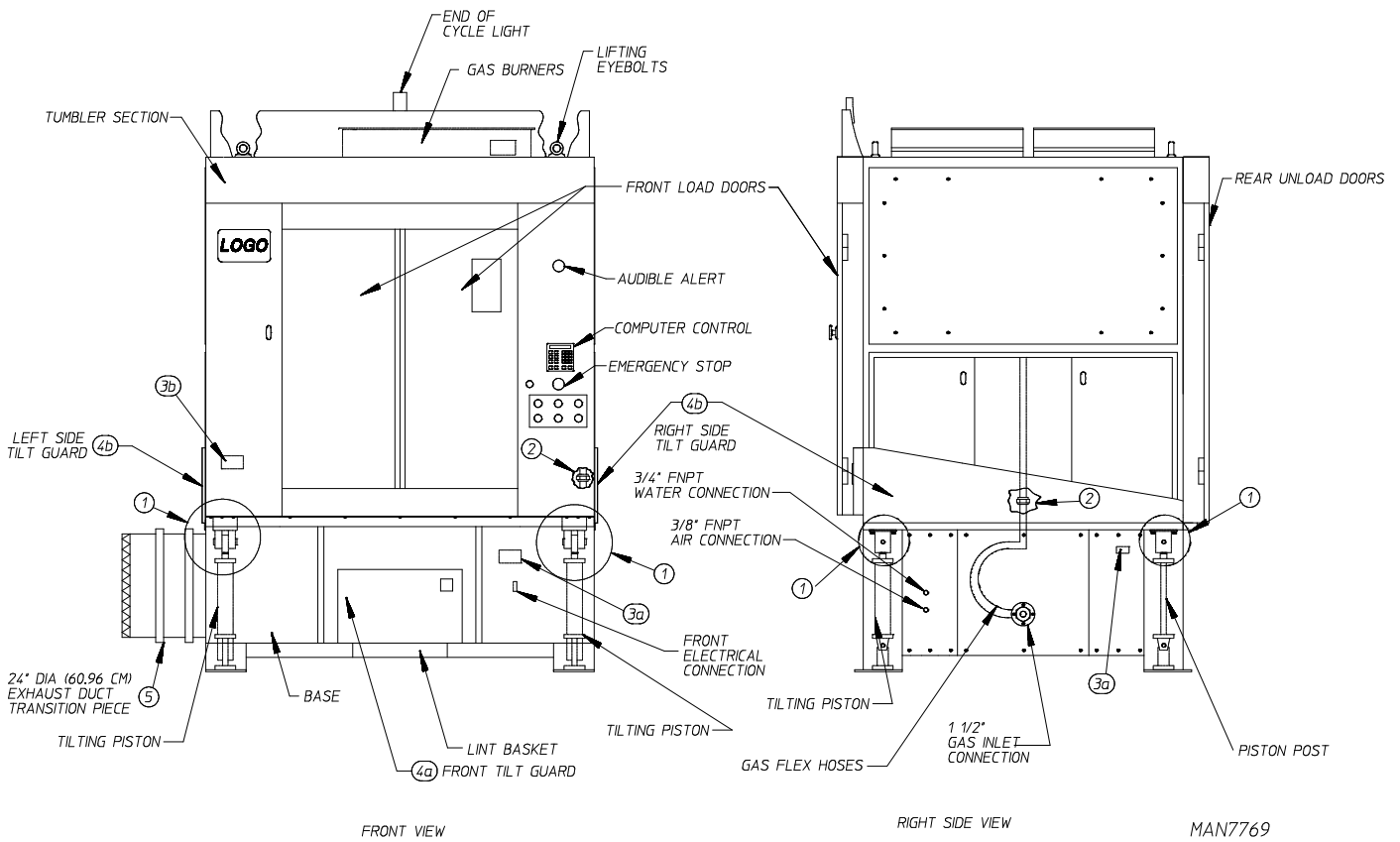

**NOTE:** ADC reserves the right to make changes in specifications at any time without notice or obligation.

PISTON/POST  
RECONNECTION VIEW ①

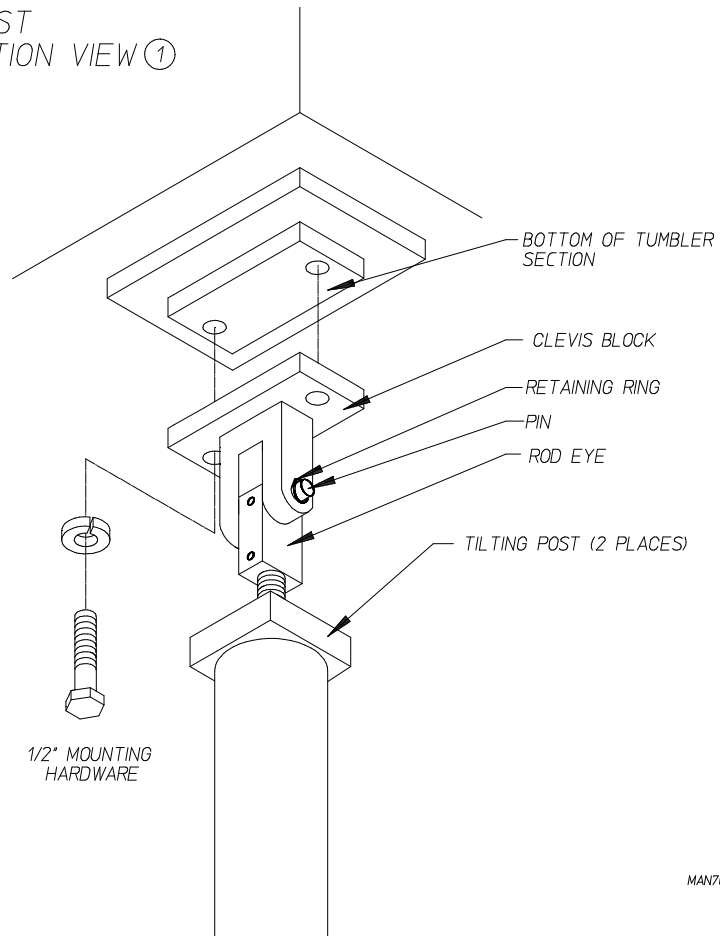

DMG 11/13/03

MAN7003

**Gas Model**

GAS FLEX HOSE  
UNION RECONNECTION  
VIEW ②

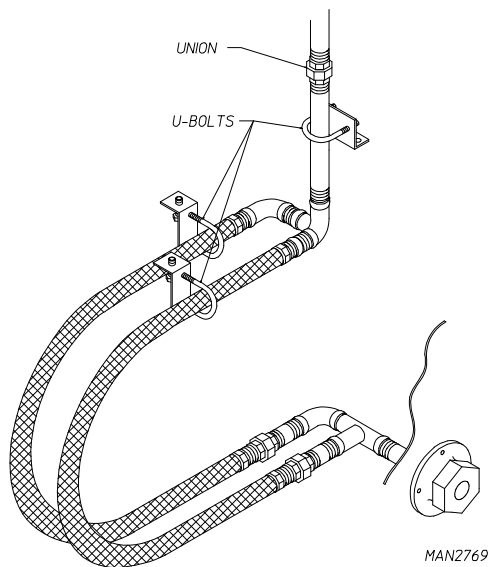

**Steam Model**

STEAM FLEX HOSE UNION RECONNECTION  
VIEW ②

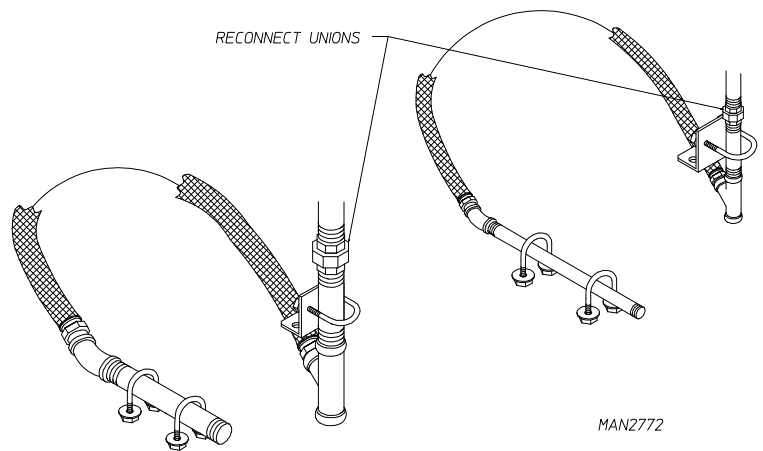

## Reassembly Instructions For Forward Tilt Dryers:

### **Lift the basket (tumbler) section onto the base.**

Tilt dryers have tilting pistons in the base. Non-tilt dryers use piston posts in the base. On the top of each piston is a clevis block. Use the four (4) 1/2" x 1-1/8" long hex head bolts with lock washers to secure each piston clevis block to the bottom of the basket (tumbler) section. (Refer to Piston/Post Reconnection [top] **View 1** on the previous page.)

#### 1. Gas Models

The flexible gas hose union is disconnected when the dryer is shipped in two (2) pieces. The flexible gas hoses are located in the right side of the base. Insert the flexible hoses with the union half up through the hole on the bottom of the basket (tumbler) section and retighten the union. The flex hoses **must not be** kinked. (Refer to [bottom left] **View 2** on the previous page.)

#### 2. Steam Models

Both the 2" steam supply line and the 1-1/4" condensate return line flexible hose unions are disconnected when the dryer is shipped in two (2) pieces. The flexible hoses are located in the right side of the base. Insert both flexible hose union halves up through the holes on the bottom of the basket (tumbler) section and retighten the unions. The flex hoses **must not be** kinked. (Refer to [bottom right] **View 2** on the previous page.)

#### 3. There are two (2) electrical reconnections:

- a. A 24-pin plug and cable and a 10-pin plug and cable are located in the right side of the base. This **must be** lifted up and reconnected into the mating socket located at the bottom of the right basket (tumbler) section.
- b. The basket (tumbler) section power cable **must be** lifted up from the base and reconnected into the junction box next to the basket (tumbler) drive motor in the left side of the basket (tumbler) section.

Make sure that reconnected cables have enough slack in them to allow the dryer to tilt freely in both directions.

#### 4. Reattach the tilt guard panels:

- a. Use 1/4-20 self-tapping screws to secure the hinged rear tilt guard panel on the rear of the base.
- b. Use round head screws to secure the tilt guard panel to the rear of the dryer.
- c. Use 1/4-20 self-tapping screws to secure the right and left side tilt panel.
- d. Use round head screws to secure the right and left lower side panels to the basket (tumbler) section.

#### 5. Secure the 24" diameter exhaust duct transition piece to the dryer's rectangular exhaust duct with the 1/4-20 self-tapping screws supplied with the dryer. The exhaust duct exits from the rear of the base.

#### 6. On dryers equipped with an optional automatic (piston operated) load door, reconnect the two (2) poly-flo air lines that run from the base up to the door pistons. Located in the right side of the base.

#### 7. Reconnect the 1/4" poly-flo air line, which runs from the base up to the steam damper solenoid valve, which is located on the top of the dryer.



# 1 DOOR TILTING MACHINE GUARD INSTALLATION

1. Remove outer panel.
2. Install guard installing screws along bottom of guard.
3. Then reinstall outer panel.
4. Repeat on right side of machine.

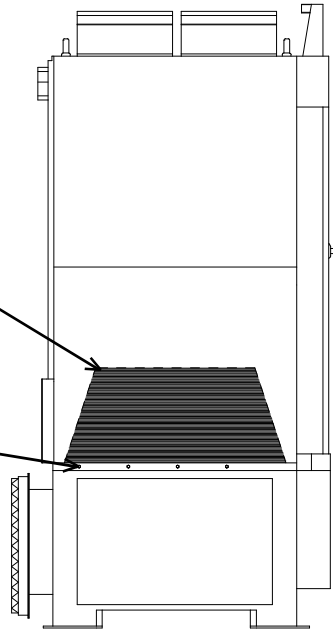

LEFT SIDE VIEW

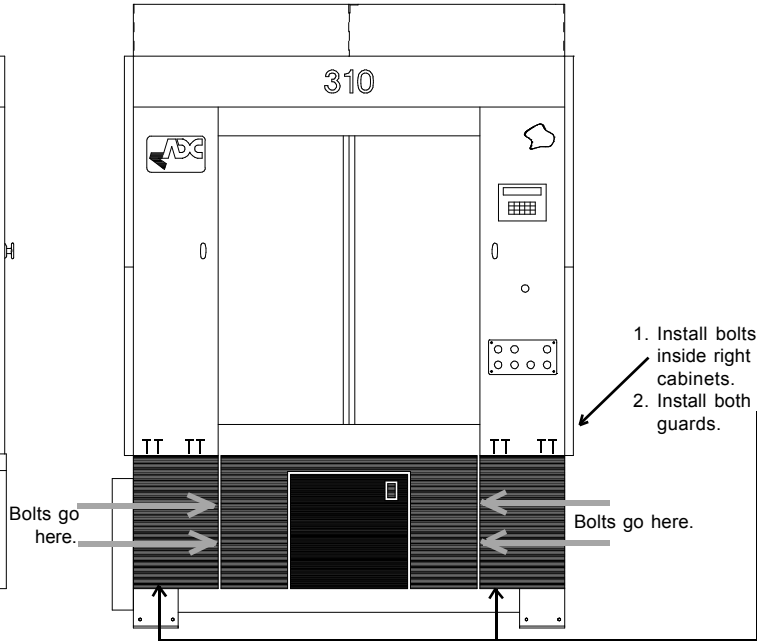

FRONT VIEW

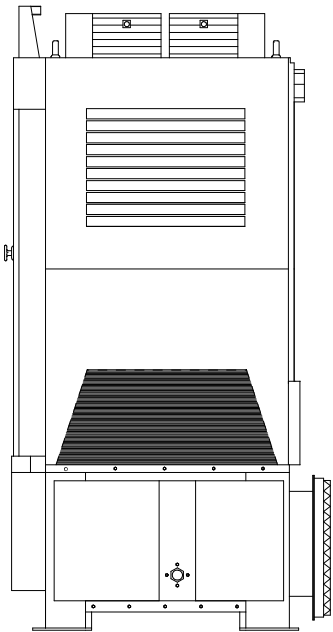

RIGHT SIDE VIEW

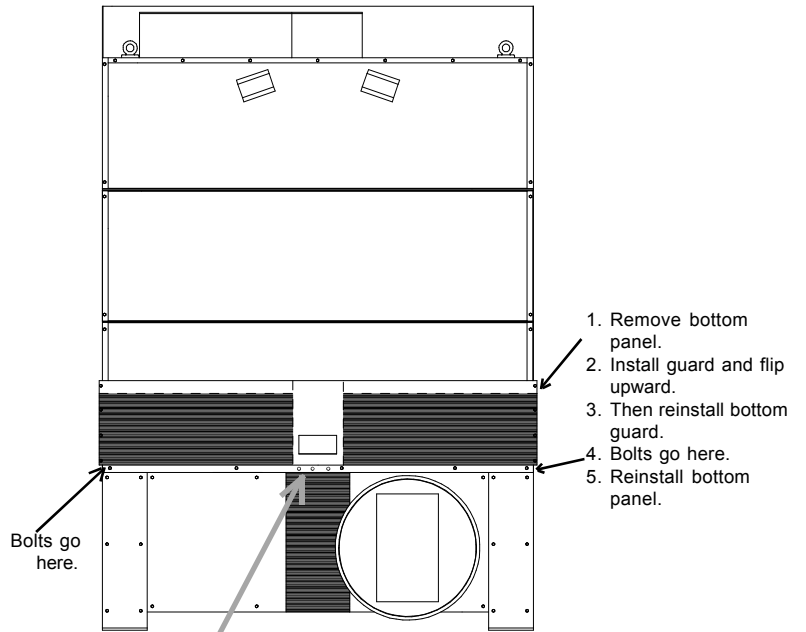

1. Bolts go here.
2. Slide into bottom panel on base.

REAR VIEW

MAN7364

# 2 DOOR TILTING MACHINE GUARD INSTALLATION

1. Remove outer panel.
2. Install guard, installing screws along bottom of guard.
3. Then reinstall outer panel.
4. Repeat on right side of machine.

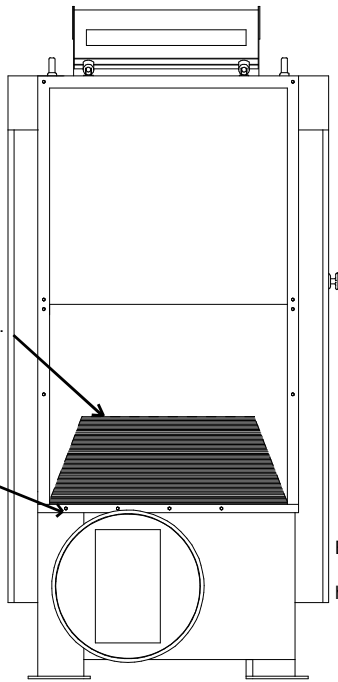

LEFT SIDE VIEW

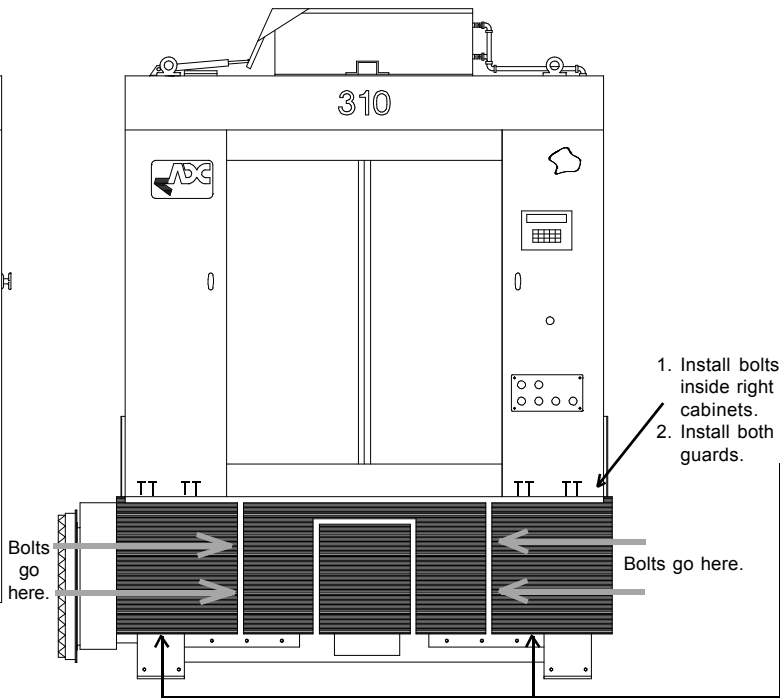

FRONT VIEW

1. Install bolts from inside right and left cabinets.
2. Install both side guards.

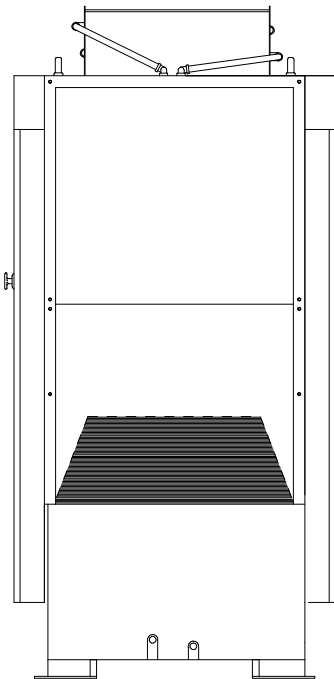

RIGHT SIDE VIEW

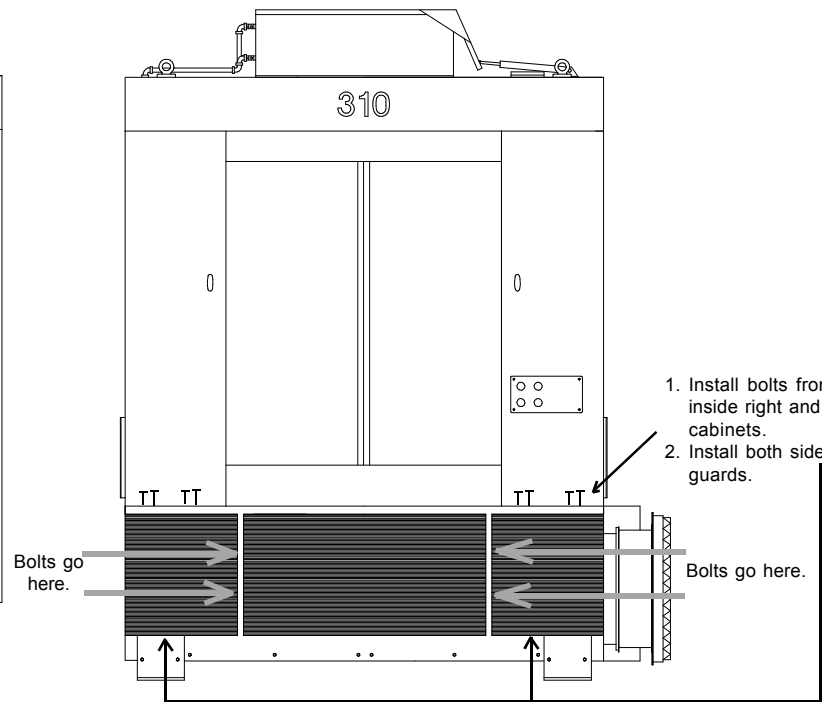

REAR VIEW

1. Install bolts from inside right and left cabinets.
2. Install both side guards.

MAN7363

## B. LOCATION REQUIREMENTS

The tilt model dryer requires 18-inches (45.72 cm) on the right side of the dryer for ease of service. The requirement for the left side clearance on a 1 door dryer is 18-inches (45.72 cm) and for a 2 door dryer 36-inches (91.44 cm) is required due to the side exhaust. The rear of the dryer requires a 36-inch (91.44 cm) clearance for ease of service. Refer to the chart below for ceiling height requirements for each of the tilting dryer models.

The dryer **must be** leveled for proper operation. If shimming is required, place 11-inch x 10-inch (27.94 cm x 25.4 cm) metal shims under the base feet. The dryer **must be** lagged to the floor.

1. The dryer **must be** installed with a proper exhaust duct connection to the outside.
2. The dryer **must be** installed with provisions for adequate combustion and make-up air supply.

| TILT CLEARANCE ALLOWANCE |                            |           |
|--------------------------|----------------------------|-----------|
| Dryer Style              | Ceiling Height Requirement |           |
| Gas                      | 138-inches                 | 350.52 cm |
| Steam                    | 141-inches                 | 358.14 cm |

Shaded areas are stated in metric equivalents

**WARNING:** Dryer *should be* located where a minimum length of exhaust duct **will be** necessary.

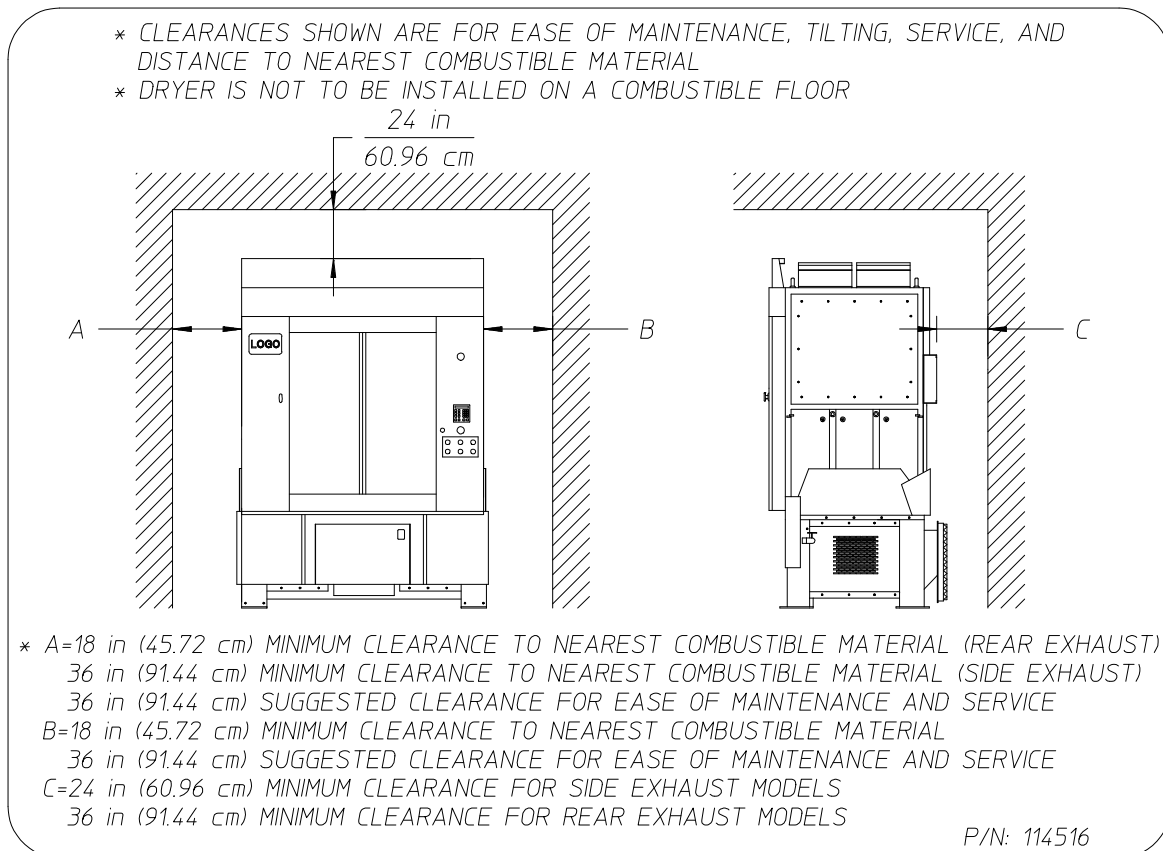

DMG 01/29/01

MAN5622

**CAUTION:** This dryer produces combustible lint and *must be* exhausted to the outdoors. Every 6 months, inspect the exhaust ducting and remove any lint buildup.

**IMPORTANT:** Dryer *must be* installed in a location/environment, which the ambient temperature remains between 40° F (4.44° C) and 130° F (54.44° C).

### C. FRESH AIR SUPPLY REQUIREMENTS

This appliance may only be installed in a room that meets the appropriate ventilation requirements specified in the national installation regulations.

When the dryer is operating, it draws in room air, heats it, passes this air through the basket (tumbler), and exhausts it out of the building. Therefore, the room air **must be** continually replenished from the outdoors. If the make-up air is inadequate, drying time and drying efficiency will be adversely affected. Ignition problems and sail switch “fluttering” problems may result, as well as premature motor failure from overheating.

The dryer **must be** installed with provisions for adequate combustion and make-up air supply.

Air supply (make-up air) **must be** given careful consideration to ensure proper performance of each dryer. An unrestricted source of air is necessary for each dryer. An airflow of 6,500 cfm (cubic feet per minute) (184.05 cmm [cubic meters per minute]) **must be** supplied to each gas dryer and 8,500 cfm (240.69 cmm) for each steam dryer. As a general rule, an unrestricted air entrance from the outdoors (atmosphere) of a minimum of 6 square feet (0.56 square meters) is required for each gas dryer and a minimum of 8 square feet (0.74 square meters) for each steam dryer.

To compensate for the use of registers or louvers used over the openings, this make-up air area **must be** increased by approximately thirty-three percent (33%). Make-up air openings **should not be** located in an area directly near where exhaust vents exit the building.

It is not necessary to have a separate make-up air opening for each dryer. Common make-up openings are acceptable. However, they **must be** set up in such a manner that the make-up air is distributed equally to **ALL** the dryers.

Allowances **must be** made for remote or constricting passageways or where dryers are located at excessive altitudes or predominantly low pressure areas.

**IMPORTANT:** Make-up air *must be* provided from a source free of dry cleaning solvent fumes. Make-up air that is contaminated by dry cleaning solvent fumes will result in irreparable damage to the motors and other dryer components.

**NOTE:** Component failure due to dry cleaning solvent fumes will VOID THE WARRANTY.

## D. EXHAUST REQUIREMENTS

**NOTE:** For 1 door dryers, the 24" diameter exhaust duct exits from the rear of the base. For 2 door dryers, the 24" diameter exhaust duct exits from the left side of the base.

### 1. General Exhaust Ductwork Information

Exhaust ductwork **should be** designed and installed by a qualified professional. Improperly sized ductwork will create excessive back pressure, which results in slow drying, increased use of energy, overheating of the dryer, and shutdown of the burner by the airflow (sail) switches, burner hi-limits, or basket (tumbler) hi-limit thermostats. The dryer **must be** installed with a proper exhaust duct connection to the outside.

**CAUTION:** This dryer produces combustible lint and **must be** exhausted to the outdoors.

**CAUTION: IMPROPERLY SIZED OR INSTALLED EXHAUST DUCTWORK CAN CREATE A POTENTIAL FIRE HAZARD.**

**NOTE:** THE DRYER **MUST BE** INDEPENDENTLY EXHAUSTED. COMMON DUCTWORK **IS NOT** ACCEPTABLE.

The exhaust ductwork **should be** laid out in such a way that the ductwork travels as directly as possible to the outdoors with as few turns as possible. Single or independent dryer venting is recommended.

The shape of the ductwork is not critical provided that the minimum cross section area is maintained. It is suggested that the use of 90° turns in ducting be avoided; use 30° and/or 45° angles instead. The radius of the elbow **should preferably be** 1-1/2 times the diameter of the duct.

**ALL** ductwork **should be** smooth inside with no projections from sheet metal screws or other obstructions, which will collect lint. When adding ducts, the ducts to be added should overlap the duct to which it is connected. **ALL** ductwork joints **must be** taped to prevent moisture and lint from escaping into the building. Additionally, inspection doors **should be** installed at strategic points in the exhaust ductwork for periodic inspection and cleaning of lint from the ductwork.

The internal dimensions of the dryer's rectangular exhaust vent ductwork is 8-1/2" x 21" (20.6 cm x 53.5 cm). A 24" diameter round transition piece is supplied. The location's exhaust duct **must be** the minimum exhaust size requirement of 24-inch (60.96 cm) round duct or 452 square inch (2,916 square centimeters) square duct. The ductwork from the dryer to the outside exhaust outlet for a horizontal run with no more than one (1) elbow **must not exceed** 43 feet (13.1 meters) for gas and 20 feet (6.09 meters) for steam dryers. (Refer to the **illustration** on **page 22**.) For locations with more than one (1) elbow, the minimum exhaust size for a gas model dryer is 28-inch (71.12 cm) round duct (615 square inch [3,967 square centimeters] duct). For a steam model, a 32-inch (81.28 cm) round duct (840 square inch [5,419 square centimeters] duct) **must be** used. The vertical duct total run on both gas and steam models **must not exceed** 50 feet (15.24 meters), which includes the use of no more than three (3) elbows (refer to the **illustration** on **page 22**).

**IMPORTANT:** For extended ductwork runs or where more than the specified number of elbows are used, a professional heating, ventilating, and air-conditioning (HVAC) firm **should be** consulted for proper venting information.

**IMPORTANT:** **It is recommended** that exhaust or booster fans NOT BE USED in the exhaust ductwork system.

GAS AND STEAM  
HORIZONTAL DRYER VENTING

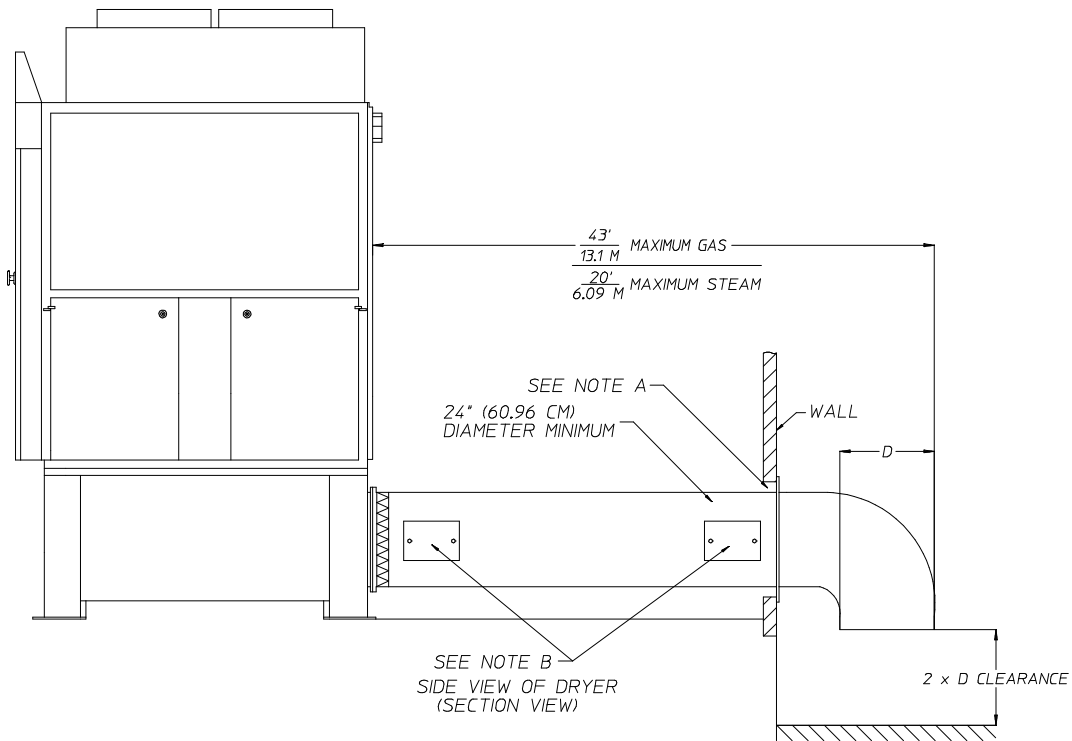

NOTE: "A"- OPENING MUST BE 2-INCHES (5.08 CM) LARGER THAN THE DUCT (ALL THE WAY AROUND). THE DUCT MUST BE CENTERED WITHIN THIS OPENING.  
"B"- INSPECTION DOORS SHOULD BE INSTALLED AT STRATEGIC POINTS FOR PERIODIC INSPECTION AND CLEANING

MAN7005

DMG 11/13/03

GAS AND STEAM  
VERTICAL DRYER VENTING

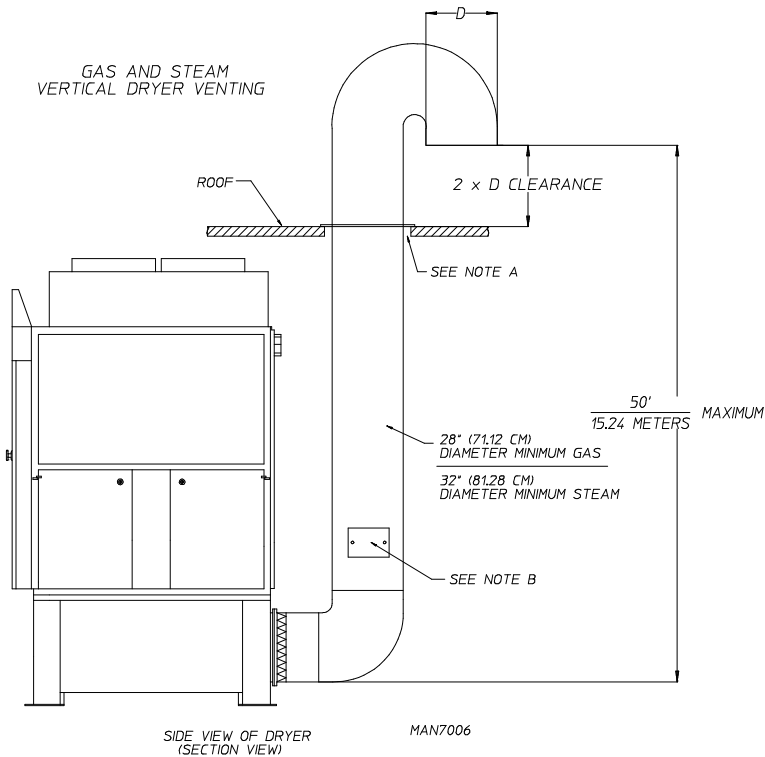

NOTE: "A"- OPENING MUST BE 2-INCHES (5.08 CM) LARGER THAN THE DUCT (ALL THE WAY AROUND). THE DUCT MUST BE CENTERED WITHIN THIS OPENING.  
"B"- INSPECTION DOORS SHOULD BE INSTALLED AT STRATEGIC POINTS FOR PERIODIC INSPECTION AND CLEANING.

DMG 11/21/03

## 2. Outside Ductwork Protection

To protect the outside end of the horizontal ductwork from the weather, a 90° elbow bent downward **should be** installed where the exhaust exits the building. If the exhaust ductwork travels vertically up through the roof, it **should be** protected from the weather by using a 180° turn to point the opening downward. In either case, allow at least twice the diameter of the duct between the duct opening and nearest obstruction.

**IMPORTANT: DO NOT** use screens, louvers, or caps on the outside opening of the exhaust ductwork.

**NOTE:** Exhaust back pressure measured by a manometer at the dryer exhaust duct area **must be** no less than 0 and **must not exceed** 0.3 inches (0.74 mb) of water column (W.C.).

**NOTE:** When the exhaust ductwork passes through a wall, ceiling, or roof made of combustible materials, the opening **must be** 2-inches (5.08 cm) larger than the duct (all the way around). The duct **must be** centered within this opening.

**NOTE:** As per the National Fuel Gas Code, “Exhaust ducts for Type 2 clothes dryers shall be constructed of sheet metal or other noncombustible material. Such ducts shall be equivalent in strength and corrosion resistance to ducts made of galvanized sheet steel not less than 26 gauge (0.0195-inches [0.50 mm]) thick.”

VERTICAL DUCTING

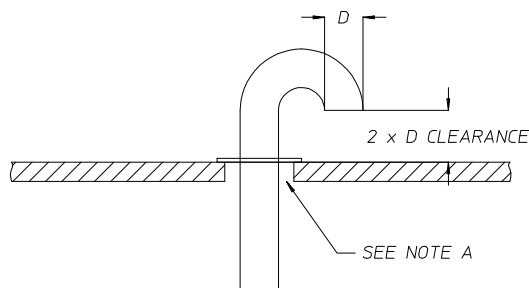

HORIZONTAL DUCTING

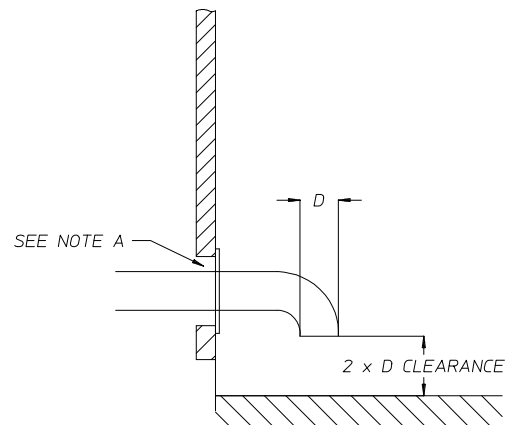

NOTE "A": OPENING MUST BE TWO (2) INCHES (5.08 CM) LARGER THAN DUCT (ALL THE WAY AROUND). THE DUCT MUST BE CENTERED WITHIN THIS OPENING.

MAN4706

## E. COMPRESSED AIR SUPPLY SYSTEM

The compressed air supply system of the tilting dryer consists of a number of pneumatic pistons located throughout the dryer. The pistons are actuated by solenoid valves that are under computer control. The pneumatic pistons are used to:

- Tilt the Dryer for Loading and Unloading
- Open and Close the Load and Unload Doors  
(for dryer models equipped with automatic doors)
- Operate the Steam Coil Damper (for Steam Heated Models Only)

### 1. Filter/Regulator/Gauge Assembly

The compressed air supply to the dryer is connected into the 3/8" F.P.T. fitting located on the right hand side of the dryer base. From there a hose leads to the filter/regulator/gauge assembly, which is located at the bottom rear of the right side of the base.

The filter/regulator/gauge assembly performs three (3) essential functions. The filter removes most solids and liquid particles from the compressed air stream and traps them in a bowl, where this waste can be readily removed through the drain valve at the bottom of the bowl.

The filter bowl **should be** cleaned monthly.

The regulator will maintain a nearly constant outlet air pressure so that the dryer's air pistons will function normally despite upstream air pressure variations. After the compressed air is connected, adjust the regulator knob so that the gauge needle reads 80 psi (5.51 bar).

### 2. Optional Piston Operated Tilting Valves

A 2-way tilt dryer has two (2) of these solenoid valves: one (1) to control the front set of tilting pistons and a second to control the rear set of tilting pistons. A 1-way tilt dryer has only one (1) solenoid valve.

Each valve has five (5) 3/8" F.P.T. ports and two (2) electric solenoid operators, one (1) on each side of the valve.

To tilt the dryer forward, a 24 volt signal is applied to the rear pistons solenoid connector "L6" and no voltage is applied to the solenoid connector "L7". On 2-way tilt dryers, a 24 volt signal is present at the front piston solenoid connector "L4", this prevents both front and rear pistons from extending their rods at the same time. The internal spool in the valve will move and 80 psi (5.51 bar) of air will enter the bottom port of the rear tilting pistons, extending the rear tilting piston rods and tilting the dryer forward for unloading. The top piston ports are bled into the atmosphere.

To level the dryer, the voltage signals are reversed. No voltage is applied to the "L6" solenoid, and 24 volts is applied to the "L7" solenoid. The valve spool will now move so that 80 psi (5.51 bar) of air is applied at the top piston ports, while the bottom piston ports are bled into the atmosphere. The piston rod will now retract leveling the dryer. On rear tilt dryers, the front tilting piston ports are bled to the atmosphere.

The tilting piston valves are 5-port/3-position valves. If no voltage is applied to both the "L6" and "L7" solenoids, **ALL** five (5) valve ports are blocked. This means that, if the dryer is tilting or leveling and the power is shut off, the pistons will lock in position, holding the dryer in a partially tilted position.

The tilting piston valves are located on the pneumatic plate in the rear of the dryer's base.



### 3. Optional Automatic (Piston Operated) Load/Unload Doors

If the dryer is equipped with the automatic door option then the loading doors are operated by two (2) pneumatic pistons located above the load doors. On 2 door dryers, the unloading doors on the back of the dryer will also be controlled by two (2) pistons, located above the unload doors.

The 24 volt solenoid valve controlling the door pistons are located on the pneumatic panel in the rear of the dryer's base. These solenoid valves are configured so that if power to the dryer is shut off, the door piston's ports are bled to the atmosphere so that the doors can be opened and closed by hand.

### 4. Steam Damper Air System Connections

The dryer is manufactured with a pneumatic (piston) damper system, which requires an external supply of compressed air. The air connection is made at the left hand side on top of the dryer.

#### a. Air Requirements

| <b>Compressed Air Supply</b> | <b>Air Pressure</b> |                 |
|------------------------------|---------------------|-----------------|
| Normal                       | 80 psi              | <b>5.51 bar</b> |
| Minimum Supply               | 70 psi              | <b>4.82 bar</b> |
| Maximum Supply               | 90 psi              | <b>6.21 bar</b> |

Shaded areas are stated in metric equivalents

#### b. Air Connection

Air connection to system – 3/8" F.P.T.

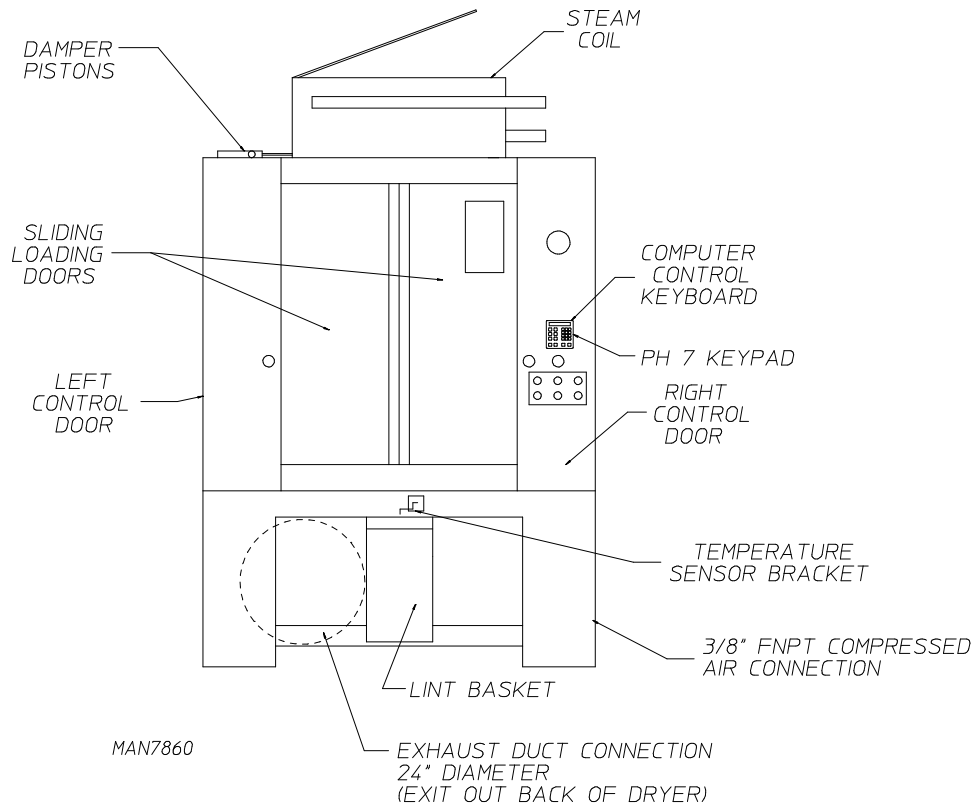

c. No air regulation or filtration is provided with the dryer. External regulation/filtration of 80 psi (5.51 bar) **must be provided**. It is suggested that a filter/regulator/gauge arrangement be added to the compressed air line just before the dryer connection. This is necessary to ensure that correct and clean air pressure is achieved.

## 5. Steam Damper System Operation

The steam damper, as shown in the **illustration below**, allows the coil to stay constantly charged eliminating repeated expansion and contraction. When the damper is opened, the air immediately passes through the already hot coil, providing instant heat to start the drying process. When the damper is closed, ambient air is drawn directly into the basket (tumbler), allowing a rapid cool down.

**Diagram 1** – shows the damper in the heating (open) mode, allowing heat into the basket (tumbler).

**Diagram 2** – shows the damper in the cool down (closed) mode, pulling ambient air directly into the basket (tumbler) without passing through the coils.

**NOTE:** With the dryer off or with no air supply, the damper is in the cool down mode as shown in **Diagram 2**.

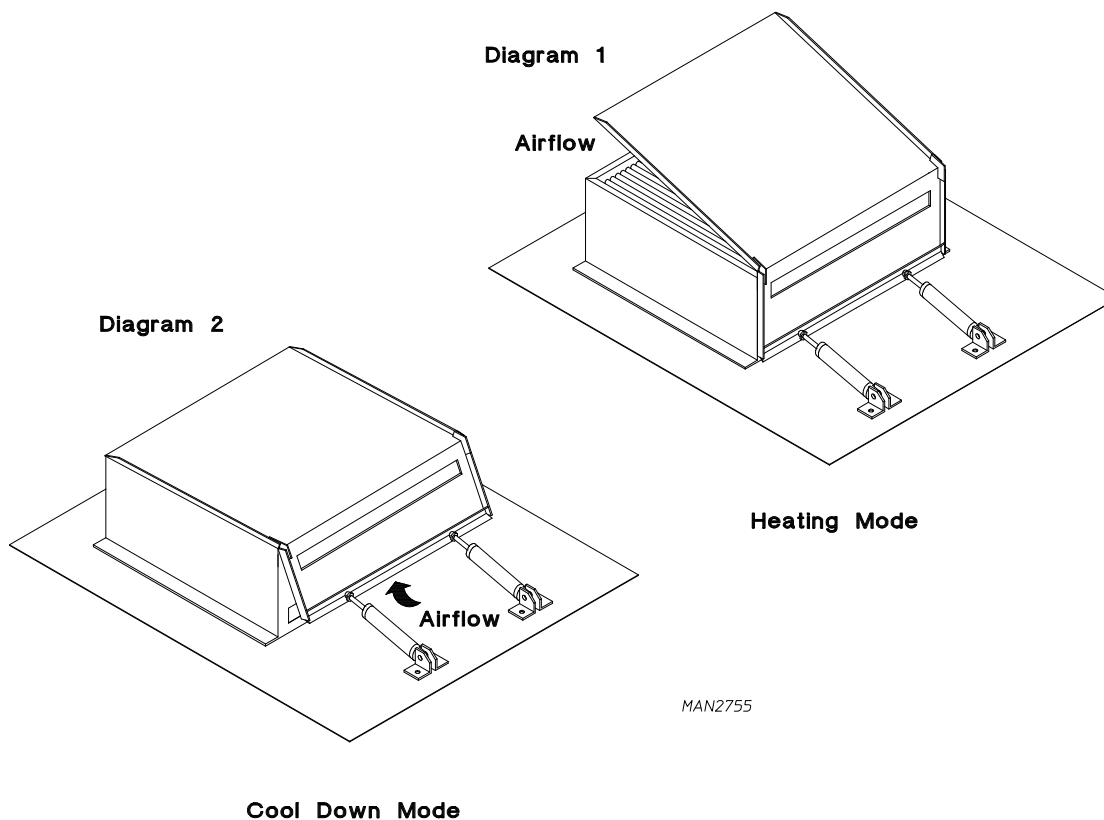

**NOTE:** Turning knob on flow control clockwise (CW) will restrict airflow. Turning knob counterclockwise (CCW) will allow higher airflow.

## 6. Steam Damper Air Piston (Flow Control) Operation Adjustment

Steam damper operation was tested and adjusted prior to shipping at 80 psi (5.51 bar). If steam damper adjustment is necessary, locate the flow control valve and make the necessary adjustments as noted below.

**NOTE:** Adjust both flow control valves equally, so that both pistons operate at the same time.

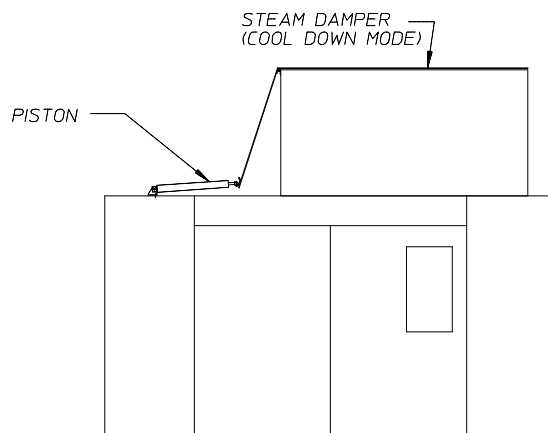
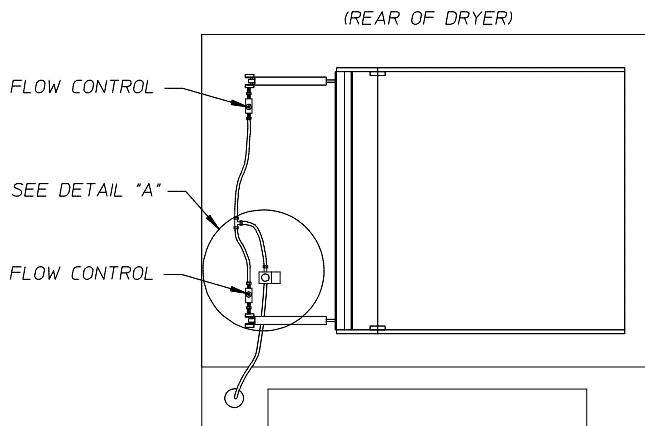

NOTE:  
TURNING KNOB ON FLOW  
CONTROL CLOCKWISE WILL  
RESTRICT AIR FLOW. TURNING  
KNOB COUNTER-CLOCKWISE WILL  
ALLOW HIGHER AIR FLOW.

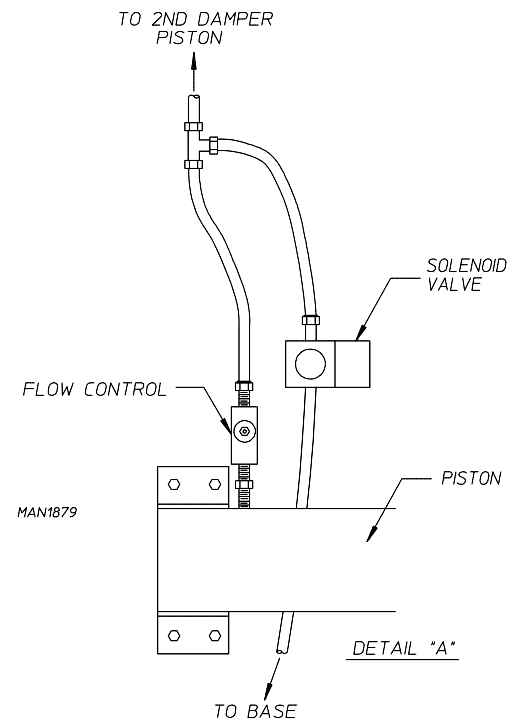

## F. ELECTRICAL INFORMATION

### 1. Electrical Requirements

**ALL electrical connections must be made by a properly licensed and competent electrician.** This is to ensure that the electrical installation is adequate and conforms to local and state regulations or codes. In the absence of such codes, **ALL** electrical connections, materials, and workmanship **must conform** to the applicable requirements of the National Electrical Code ANSI/NFPA NO. 70-LATEST EDITION or in Canada, the Canadian Electrical Codes Parts 1 & 2 CSA C22.1-1990 or LATEST EDITION.

**IMPORTANT:** Failure to comply with these codes or ordinances, and/or the requirements stipulated in this manual can result in personal injury or component failure.

**NOTE:** Component failure due to improper installation will VOID THE WARRANTY.

Each dryer **should be** connected to an independently protected branch circuit. The dryer **must be** connected with copper wire only. ***DO NOT use aluminum wire, which could cause a fire hazard.*** The copper conductor wire/cable **must be** of proper ampacity and insulation in accordance with electric codes for making **ALL** service connections.

**NOTE:** The use of aluminum wire will VOID THE WARRANTY.

**IMPORTANT:** A separate protected circuit ***must be*** provided to each dryer.

**NOTE:** An individual ground circuit ***must be*** provided to each dryer, ***DO NOT*** daisy chain.

**IMPORTANT:** The dryer ***must be*** connected to the electric supply, shown on the data label. In the case of 208 VAC or 230/240 VAC, the supply voltage must match the electric service specifications of the data label **exactly**.

**IMPORTANT:** The wire size ***must be*** properly sized to handle the related current.

**WARNING:** **208 VAC AND 230/240 VAC ARE NOT THE SAME**. Any damage done to dryer components due to improper voltage connections will automatically VOID THE WARRANTY.

**NOTE:** Component failure due to improper voltage application will VOID THE WARRANTY.

**NOTE:** ADC reserves the right to make changes in specifications at any time without notice or obligation.

2. Electrical Service Specifications

| ELECTRICAL SERVICE SPECIFICATIONS (PER DRYER)   |       |              |                  |       |                 |
|---|-------|--------------|------------------|-------|-----------------|
| <b>IMPORTANT:</b> 208 VAC AND 230/240 VAC ARE NOT THE SAME. When ordering, specify exact voltage.   |       |              |                  |       |                 |
| <b>NOTES:</b> A. When fuses are used they must be dual element, time delay, current limiting, class RK1 or RK5 ONLY. Calculate/determine correct fuse value, by applying either local and/or National Electrical Codes to listed appliance amp draw data. |       |              |                  |       |                 |
| B. Circuit breakers are thermal-magnetic (industrial) motor curve type ONLY. For others, calculate/verify correct breaker size according to appliance amp draw rating and type of breaker used.   |       |              |                  |       |                 |
| C. Circuit breakers for 3-phase (3Ø) dryers must be 3-pole type.  |       |              |                  |       |                 |
| SERVICE VOLTAGE   | PHASE | WIRE SERVICE | APPROX. AMP DRAW |       | CIRCUIT BREAKER |
|   |       |              | 60 Hz            | 50 Hz |                 |
| <b>GAS – REAR EXHAUST</b>   |       |              |                  |       |                 |
| 208   | 3Ø    | 3            | 61.2             | —     | 90              |
| 220   | 3Ø    | 3            | 58.6             | —     | 90              |
| 230   | 3Ø    | 3            | 69.0             | 67.4  | 90              |
| 240   | 3Ø    | 3            | 56.5             | —     | 90              |
| 380   | 3Ø    | 3/4          | 36.6             | 35.0  | 60              |
| 400   | 3Ø    | 3/4          | —                | 33.9  | 60              |
| 416   | 3Ø    | 3/4          | —                | 33.2  | 50              |
| 460   | 3Ø    | 3            | 29.1             | —     | 50              |
| 480   | 3Ø    | 3            | 29.6             | —     | 50              |
| 575   | 3Ø    | 3            | 23.2             | —     | 40              |
| <b>STEAM / GAS – SIDE EXHAUST</b>   |       |              |                  |       |                 |
| 208   | 3Ø    | 3/4          | 94.0             | —     | 125             |
| 220   | 3Ø    | 3            | 85.5             | —     | 125             |
| 230   | 3Ø    | 3            | —                | 108.8 | 150             |
| 240   | 3Ø    | 3            | 85.3             | —     | 110             |
| 380   | 3Ø    | 3/4          | —                | 50.4  | 80              |
| 400   | 3Ø    | 3/4          | —                | 51.0  | 80              |
| 416   | 3Ø    | 3/4          | —                | 48.6  | 70              |
| 460   | 3Ø    | 3            | 44.8             | —     | 70              |
| 480   | 3Ø    | 3            | 43.4             | —     | 70              |
| 575   | 3Ø    | 3            | 38.0             | —     | 60              |

8/13/14

### 3. Electrical Connections

**NOTE:** A wiring diagram is included with each dryer and is located in the blueprint pocket inside the left side control cabinet.

The main electrical input connections to the dryer are the 3-phase (3 $\phi$ ) power leads (L1, L2, and L3), GROUND, and in the case of 4 wire service, the Neutral. The electrical connections are made at the power distribution block located in the base front electrical enclosure.

The main electrical (3-phase [3 $\phi$ ]) connections (L1, L2, and L3) **must be** provided and installed in accordance with state and local codes. In the absence of these codes, grounding **must conform** to applicable requirements of the National Electrical Code ANSI/NFPA NO. 70-LATEST EDITION, or in Canada, the installation **must conform** to applicable Canadian Standards: Canadian Electrical Codes Parts 1 & 2 CSA C22.1-1990 or LATEST EDITION (for Electrical Connections).

**NOTE: A CIRCUIT SERVICING EACH DRYER *MUST BE* PROVIDED.**

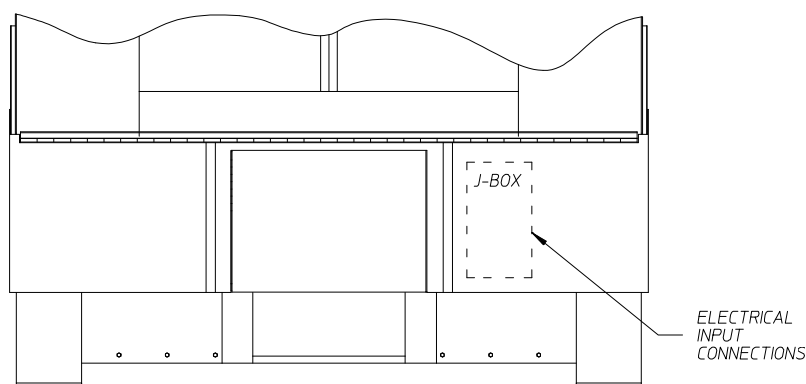

FRONT VIEW OF BASE

MAN5639

### 4. Main Grounding

A ground (earth) connection **must be** provided and installed in accordance with state and local codes. In the absence of these codes, grounding **must conform** to applicable requirements of the National Electrical Code ANSI/NFPA NO. 70-LATEST EDITION, or in Canada, the installation **must conform** to applicable Canada Standards: Canadian Electrical Codes Parts 1 & 2 CSA C22.1-1990 or LATEST EDITION. The ground connection may be to a proven earth ground at the location service panel.

**NOTE:** A grounding connection (terminal lug) is provided in the dryer in the base electrical junction box.

For added personal safety, when possible, it is suggested that a separate ground wire (no. 18 minimum) be connected from the ground connection of the dryer to a grounded cold water pipe. **DO NOT ground to a gas pipe or hot water pipe.** The grounded cold water pipe must have metal-to-metal connection **ALL** the way to the electrical ground. If there are any nonmetallic interruptions, such as, a meter, pump, plastic, rubber, or other insulating connectors, they **must be** jumped out with no. 4 copper wire and securely clamped to bare metal at both ends.

**IMPORTANT:** For personal safety and proper operation, the dryer **must be** grounded. For proper operation of the microprocessor controller (computer), an earth (zero) ground is required.

**NOTE:** Grounding via metallic electrical conduit (pipe) **is not recommended.**

## G. GAS INFORMATION

It is your responsibility to have **ALL** plumbing connections made by a qualified professional to ensure that the gas plumbing installation is adequate and conforms with local and state regulations or codes. In the absence of such codes, **ALL** plumbing connections, materials, and workmanship **must conform** to applicable requirements of the National Fuel Code ANSI Z223.1-LATEST EDITION or in Canada, CAN/CGA-B149.1-M91 (Natural Gas) or CAN/CGA-B149.2-M91 (Liquid Propane [L.P.] Gas) or LATEST EDITION (for General Installation and Gas Plumbing), as well as local codes and ordinances and **must be** done by a qualified professional.

In Australia, the fuel gas code is AS 5601/AG 601, local authority, gas, electricity, and any other relevant statutory regulations.

**IMPORTANT:** Failure to comply with these codes or ordinances, and/or the requirements stipulated in this manual, can result in personal injury and improper operation of the dryer.

**WARNING:** Twisting of the gas line may cause premature failure.

**NOTE:** On a yearly basis flex gas lines **must be** inspected for leaks, if any signs of fraying or abrasion are found the gas line **must be** replaced.

The dryer and its individual shutoff valve **must be** disconnected from the gas supply piping system during any pressure testing of that system at test pressures in excess of 1/2 psig (3.5 kPa). The dryer **must be** isolated from the gas supply piping system by closing its individual manual shutoff valve during any pressure test of the gas supply system at test pressures equal to or less than 1/2 psig (3.5 kPa).

**IMPORTANT:** Failure to isolate or disconnect dryer from supply as noted can cause irreparable damage to the gas valve, which will VOID THE WARRANTY.

**WARNING: FIRE OR EXPLOSION COULD RESULT** due to failure of isolating or disconnecting the gas supply as noted.

### 1. Gas Supply

The gas dryer installation **must meet** the American National Standard...National Fuel Gas Code ANSI Z223.1-LATEST EDITION, or in Canada, CAN/CGA-B149.1-M91 (Natural Gas) or CAN/CGA-B149.2-M91 (L.P. Gas) or LATEST EDITION (for General Installation and Gas Plumbing), as well as local codes and ordinances and **must be** done by a qualified professional.

**NOTE:** Undersized gas piping will result in ignition problems, slow drying, increased use of energy, and can create a safety hazard.

The dryer **must be** connected to the type of heat/gas indicated on the dryer label. If this information does not agree with the type of gas available, **DO NOT operate the dryer**. Contact the reseller who sold the dryer or contact the ADC factory.

**IMPORTANT:** Any burner changes or conversions **must be** made by a qualified professional.

The input ratings shown on the dryer data label are for elevations up to 2,000 feet (609.6 meters) unless elevation requirements over 2,000 feet (609.6 meters) were specified at the time the dryer order was placed with the factory. The adjustment or conversion of the dryers in the field for elevations over 2,000 feet (609.6 meters) is made by changing each burner orifice. If this conversion is necessary, contact the reseller who sold the dryer or contact the ADC factory.

## 2. Technical Gas Data

### a. Gas Specifications

| <b>TYPE OF GAS</b> |                        |                        |                  |                |
|--------------------|------------------------|------------------------|------------------|----------------|
|                    | NATURAL                |                        | LIQUID PROPANE   |                |
| Manifold Pressure* | 3.5 inches W.C.        | <b>8.7 mb</b>          | 10.5 inches W.C. | <b>26.1 mb</b> |
| In-Line Pressure   | 6.0 - 12.0 inches W.C. | <b>14.92 - 29.9 mb</b> | 11.0 inches W.C. | <b>27.4 mb</b> |

Shaded areas are stated in metric equivalents

\*Measured at gas valve pressure taps when the gas valves are on.

### b. Gas Connections:

Run a 1-1/2" pipe from the main gas header to the dryer. There is a 1-1/2" gas pipe connection at the bottom right side of the dryer's base.

Inlet connection ----- 1-1/2" N.P.T.

Btu/hr input (per dryer) ---- 1,125,000 Btu/hr (283,500 kcal/hr)

#### 1) Natural Gas

Pressure regulation is controlled by both gas valve's internal regulators. Incoming supply pressure **must be** consistent between a minimum of 6.0 inches (14.92 mb) water column (W.C.) and a maximum of 12.0 inches (29.9 mb) water column.

**NOTE:** Natural gas model is CSA approved.

2) Liquid propane (L.P.) gas have both of their gas valve's internal pressure regulators blocked open so that the gas pressure **must be** regulated upstream of the dryer. The pressure measured at each gas valve pressure tap **must be** a consistent 10.5 inches (26.1 mb) water column. There is no regulator or regulation provided in an L.P. gas dryer. The water column **must be** regulated at the source (L.P. tank) or external regulator/regulation **must be** added to each dryer.

### 3. Piping/Connections

**ALL** components/materials **must conform** to National Fuel Gas Code Specifications ANSI Z223.1-LATEST EDITION, or in Canada, CAN/CGA-B149.1-M91 (Natural Gas) or CAN/CGA-B149.2-M91 (Liquid Propane [L.P.] Gas) or LATEST EDITION (for General Installation and Gas Plumbing), as well as local codes and ordinances and **must be** done by a qualified professional. It is important that gas pressure regulators meet applicable pressure requirements, and that gas meters be rated for the total amount of **ALL** the appliance Btu being supplied.

The dryer is provided with a 1-1/2" N.P.T. inlet pipe connection located at the right side of the base of the dryer. For ease of servicing, the gas supply line of each dryer must have its own shutoff valve.

The size of the main gas supply line (header) will vary depending on the distance this line travels from the gas meter or, in the case of L.P. gas, the supply tank, other gas-operated appliances on the same supply line, etc. Specific information regarding supply line size **should be** determined by the gas supplier.



**NOTE: Undersized gas supply piping can create a low or inconsistent pressure, which will result in erratic operation of the burner ignition system.**

TYPICAL NATURAL GAS INSTALLATION

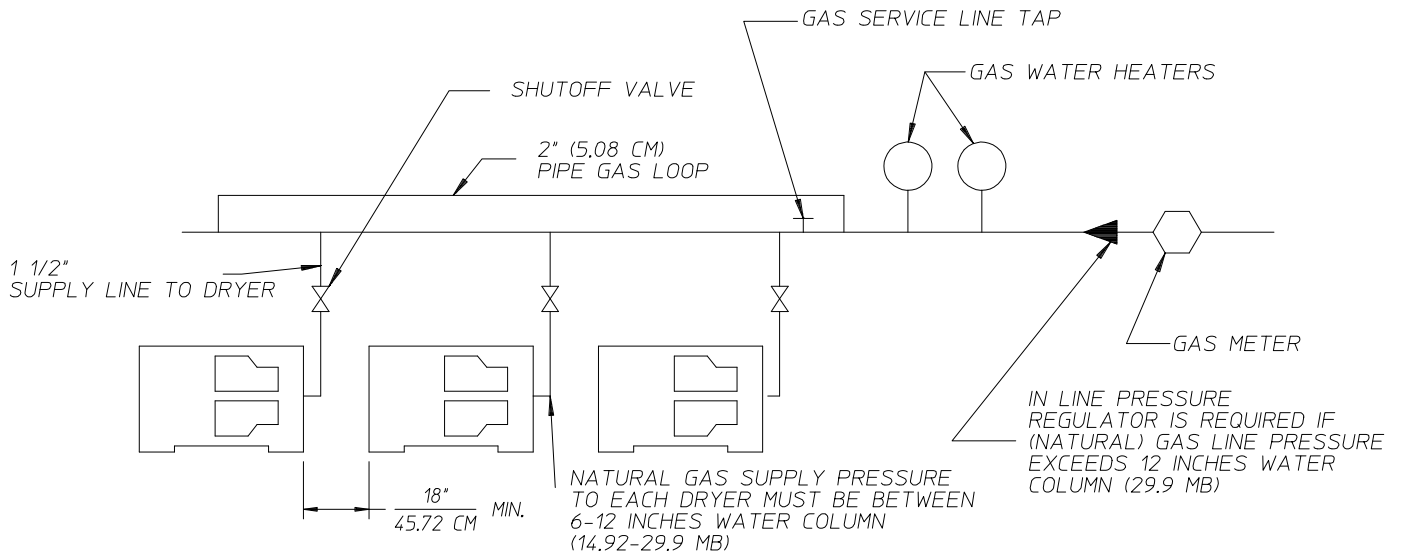

TYPICAL L.P. GAS INSTALLATION

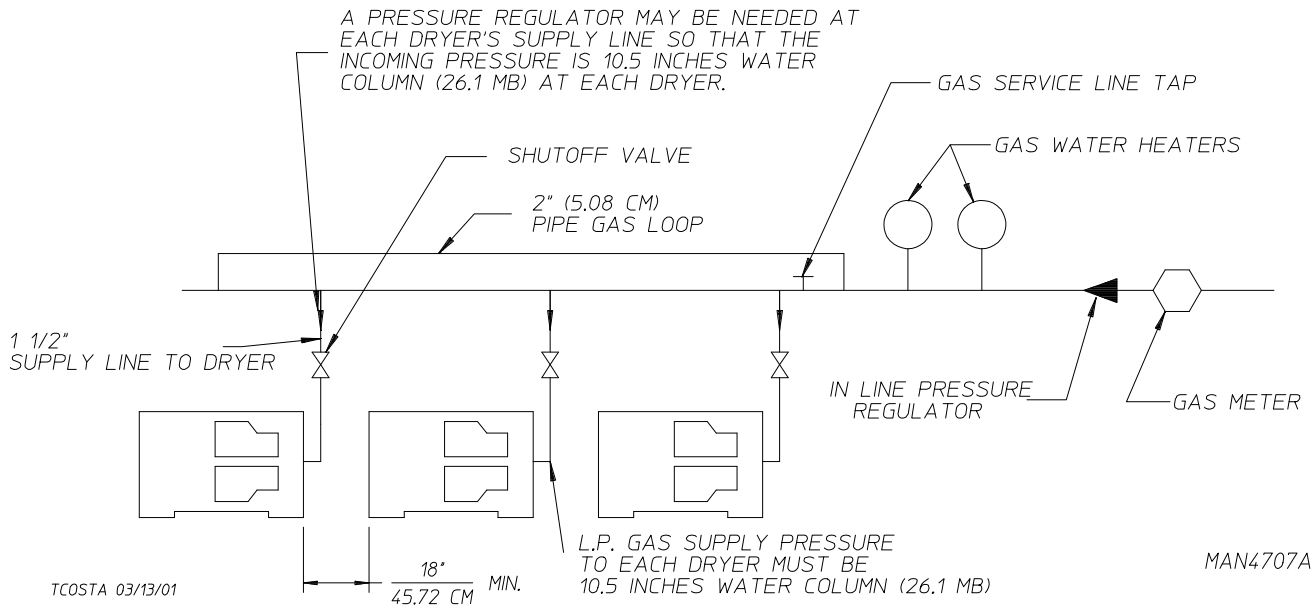

Consistent gas pressure is essential at **ALL** gas connections. It is recommended that a 2-inch (5.08 cm) pipe gas loop be installed in the supply line servicing a bank of dryers. An in-line pressure regulator **must be** installed in the gas supply line (header) if the (natural) gas pressure exceeds 12.0 inches (29.9 mb) of water column pressure.

**IMPORTANT:** A water column pressure of 3.5 inches (8.7 mb) for natural gas or 10.5 inches (26.1 mb) for liquid propane (L.P.) gas dryers is required at the gas valve pressure tap of each dryer for proper and safe operation.

A 1/8" N.P.T. plugged tap, accessible for a test gauge connection, **must be** installed in the main gas supply line immediately upstream of each dryer.

**IMPORTANT:** Pipe joint compounds that resist the action of natural and L.P. gases **must be** used.

**IMPORTANT:** Test **ALL** connections for leaks by brushing on a soapy solution (liquid detergent works well).

**WARNING: NEVER TEST FOR GAS LEAKS WITH A FLAME!!!**

**IMPORTANT:** The dryer and its individual shutoff valve **must be** disconnected from the gas supply piping system during any pressure testing of that system at test pressures in excess of 1/2 psig (3.5 kPa).

**NOTE:** The dryer **must be** isolated from the gas supply piping system by closing its individual manual shutoff valve during any pressure testing of the gas supply piping system at test pressures equal to or less than 1/2 psig (3.5 kPa).

## H. STEAM INFORMATION

It is your responsibility to have **ALL** steam plumbing connections made by a qualified professional to ensure that the installation is adequate and conforms with local and state regulations or codes.

**IMPORTANT:** Failure to comply with the requirements stipulated in this manual can result in component failure, which will VOID THE WARRANTY.

**NOTE:** The dryer is manufactured with a pneumatic (piston) damper system, which requires an external supply of clean, dry, and regulated air (80 psi ± 10 psi [5.51 bar ± 0.68 bar]).

### 1. Steam Coil pH Level

The normal for copper type steam coils **must be** maintained between a value of 8.5 to 9.5. For steel type steam coils the pH level **must be** maintained between a value of 9.5 to 10.5. These limits are set to limit the acid attack of the steam coils.

**IMPORTANT:** Coil failure due to improper pH level will VOID THE WARRANTY.

### 2. Steam Requirements – High Pressure

Inlet ----- 2” supply line connection

Return ----- 1-1/4” return line connection

| <b>Operating Steam Pressure</b> |             |                   |
|---------------------------------|-------------|-------------------|
| Maximum                         | 125 psig*   | <b>861.84 kPa</b> |
| Heat Input (Normal Load)        | 35 Bhp      |                   |
| Consumption (Approximate)       | 1,153 lb/hr | <b>524 kg/hr</b>  |

Shaded areas are stated in metric equivalents

\* The minimum operating pressure for optimum results is 100 psig (689.47 kPa).

### 3. Installation Instructions

To ensure that adequate supply of steam is provided, be sure that the steam supply and steam return lines are sized and laid out as stipulated in this manual. Inadequate steam supply and steam return lines or improper steam plumbing will result in poor performance and can cause component failure. Clean, dry, regulated steam **must be** provided to the dryer.

**IMPORTANT:** Steam coil failure due to water hammer by wet steam will VOID THE WARRANTY.

- a. The presence of the condensate in the steam supply line will cause water hammer and subsequent heat exchanger (steam coil) failure. The steam supply connection into the main supply line **must be** made with a minimum 10-inch (25.4 cm) riser. This will prevent any condensate from draining towards the dryer.
- b. The steam supply piping to the dryer must include a 12-inch (30.48 cm) riser along with a drip trap and check valve. This will prevent any condensate from entering the steam coil.
- c. Flexible hoses or couplings **must be** used. The dryer vibrates slightly when it runs and this will cause the steam coil connections to crack if they are hard piped to the supply and return mains.
- d. Shutoff valves for each dryer **should be** installed in the supply, return, and drip trap return lines. This will allow the dryer to be isolated from the supply and return mains if the dryer needs maintenance work.
- e. Install an inverted bucket steam trap and check valve for each unit at least 12-inches (30.48 cm) below steam coil as close to the coil as possible.
- f. The supply and return lines **should be** insulated. This will save energy and provide for safety of the operator and maintenance personnel.
- g. Water pockets in the supply line, caused by low points, will provide wet steam to the coil possibly causing coil damage. **ALL** horizontal runs of steam supply piping **should be** pitched 1/4-inch for every 1 foot (0.30 meters) back towards the steam supply header causing any condensate in the line to drain the header. Install a bypass trap in any low point to eliminate wet steam.

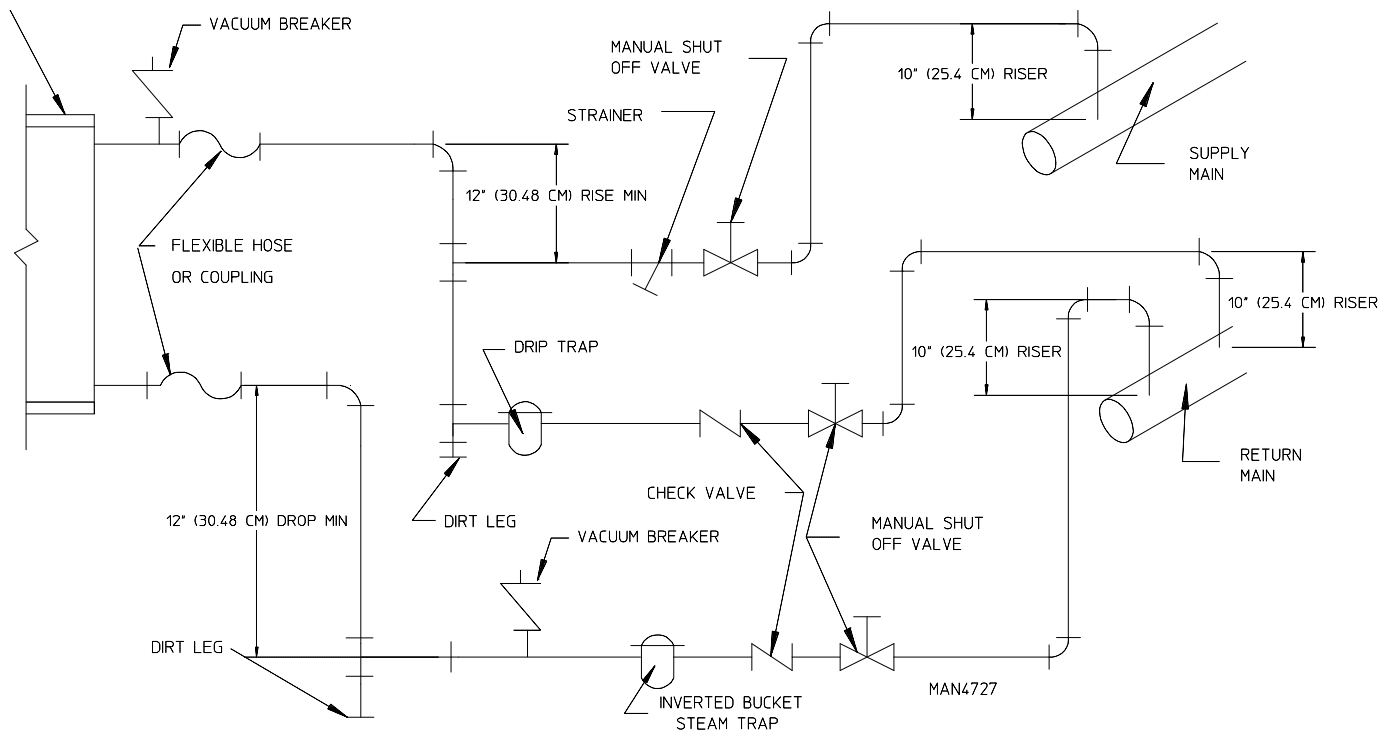



## I. PREOPERATIONAL TEST

**ALL** dryers are thoroughly tested and inspected before leaving the factory. However, a preoperational test **should be** performed before the dryer is publicly used. It is possible that adjustments have changed in transit or due to marginal location (installation) conditions. Installer must instruct the user on how to correctly operate the dryer before leaving.

1. Turn on electric power to the dryer.
2. Make sure the loading doors are closed and the lint drawer is closed.
3. Press in “green” power button and it will illuminate.
4. Microprocessor controller (computer) system operational test – to start the dryer:
  - a. Display will read “READY”.
  - b. Press “D” (preprogrammed) cycle key on the keypad.
5. The dryer will then start (i.e., blower, basket [tumbler], and heat).
6. The light emitting diode (L.E.D.) display will read MANUAL DRYING CYCLE D, 00:00 MIN REMAIN.

**NOTE:** Press the “UP ARROW” to view the basket (tumbler) temperature at any time.

**NOTE:** The dryer can be stopped at any time by pressing the “STOP/CLEAR”  key. If the temperature is above the Cool Down set point when the “STOP/CLEAR”  key is pressed, the dryer will go into a Cool Down Cycle. If the “STOP/CLEAR”  key is pressed again at this point the cycle that was in progress **will be canceled** and returned to the “READY” state. If the temperature is below the Cool Down set point, the cycle that was in progress **will be canceled**, and go into Wrinkle Guard Cycle.

7. When the programmed drying time has expired, the Phase 7 non-coin microprocessor controller (computer) will proceed into the Cool Down Cycle (Mode).
8. Once the Cool Down Cycle begins at the end of the heat cycle, the L.E.D. display will read COOL DOWN TEMP \_\_\_/\_\_\_ MINUTE REMAINING. At the end of the heat cycle, the dryer will shut off the heat and continue the fan and basket (tumbler) until the Cool Down time, or temperature is reached.
9. Once the Cool Down Cycle is completed the Phase 7 non-coin microprocessor controller (computer) will proceed into the Wrinkle Guard Cycle. The Audio Alert tone will sound prior to the start of the Wrinkle Guard Cycle. The L.E.D. display will read “WRINKLE GUARD”. The times are fixed at 2 minutes OFF, 2 minutes ON for a maximum time of 99 minutes. These times are not programmable. During the ON time, the blower (fan) and the basket (tumbler) will start to rotate (without heat for 2 minutes). The Phase 7 non-coin microprocessor controller (computer) will repeat this process until the Maximum Wrinkle Guard On Time has expired (99 minutes). The L.E.D. display will then read “CYCLE DONE” and lockout the dryer functions until the doors are opened. It will then return to “READY”.

**NOTE:** Mechanical functions of the dryer **are not** allowed during the ON time. The blower (fan) **must be** OFF to perform mechanical functions. However the “STOP/CLEAR”  key may be pressed at any time to end the Wrinkle Guard Cycle. Mechanical functions of the dryer is allowed during the OFF time.

**NOTE:** Dryer can be stopped at any time by pressing the “STOP/CLEAR”  key twice. The display will show “READY”, at this time a new keyboard (touch pad) key function *must be* selected for the dryer to operate.

**NOTE:** The six (6) preprogrammed drying cycles (“A” thru “F”) have been stored in the microprocessor controller’s (computer’s) memory. Pressing one (1) of the programmed keys will start the dryer. Refer to the Programming Manual supplied with the dryer for these preprogrammed cycles.

10. Check to ensure that the basket (tumbler) starts in the clockwise (CW) direction. Additionally, check the direction of the blower motor to ensure that it rotates in the counterclockwise (CCW) direction as viewed from the left side of the dryer. If it does, the phasing is correct. If the phasing is incorrect, reverse two (2) of the leads at L1, L2, or L3 of the power supply connections made to the dryer.

**IMPORTANT:** Dryer blower motor and impellor/fan shaft as viewed from the left side of the dryer must turn in the counterclockwise (CCW) direction, otherwise the dryer efficiency will be drastically reduced, and premature component failure can result.

#### 11. Heat Circuit Operational Test

##### a. Gas Models

- 1) When the dryer is first started (during initial start-up), the burners have a tendency not to ignite on the first attempt. This is because the gas supply piping is filled with air, so the dryer may have to be stopped and restarted several times for this air to be purged from the lines.
- 2) The dryer has two (2) burner boxes and each burner has its own Direct Spark Ignition (DSI) Module and Spark Ignitor/Flame-Probe Assembly. If ignition is not established after first attempt, the heat circuit DSI Module will lockout until it is manually reset. To reset the DSI system, open and close the loading doors and restart the dryer (press “ENTER/START” key).

If one (1) burner lights and the other does not, then the system will shut both burners off and the burner fault code will be displayed showing which of the two (2) burners failed to ignite.

**NOTE:** During the purging period, verify that ALL gas shutoff valves are open.

- 3) Once ignition is established, a gas pressure test **should be** taken at each gas valve pressure tap of the dryer to ensure that the water column (W.C.) pressure is correct and consistent.

**NOTE:** Water column pressure requirements (measured at both gas valve pressure taps):

Natural Gas ----- 3.5 inches (8.7 mb) water column.

Liquid Propane (L.P.) Gas ----- 10.5 inches (26.1 mb) water column.

**IMPORTANT:** There is no regulator provided in an L.P. dryer. The water column pressure *must be* regulated at the source (L.P. tank), or an external regulator *must be* added to each dryer.

## b. Steam Models

- 1) Check to ensure that the steam damper is functioning properly.
- 2) Make a complete operational check of **ALL** safety-related circuits (i.e., lint drawer switch and sail switches on gas models).
- 3) Reversing basket (tumbler) dryers should never be operated with less than a 204 lb (92.53 kg) load (dry weight), since the load's weight affects basket (tumbler) coast time during a direction reversal command. It is important that the basket (tumbler) come to a complete stop prior to starting in opposite direction. For automatic (mode) cycle only, the spin and stop times are not adjustable and have been preprogrammed into the microprocessor controller (computer) for a 2-1/2 minute reverse spin time and a 7-second dwell (stop) time.

## BASKET (TUMBLER) COATING

The basket (tumbler) is treated with a protective coating. We suggest dampening old garments or cloth material with a solution of water and nonflammable mild detergent and tumbling them in the basket (tumbler) to remove this coating.

- 4) Each dryer **should be** operated through one (1) complete cycle to ensure that no further adjustments are necessary and that **ALL** components are functioning properly.
- 5) Microprocessor controller (computer) programs/selections – each microprocessor controller (computer) has been preprogrammed by the factory with the most commonly used parameter (programs) selections. If computer program changes are required, refer to the Computer Programming Manual, which was shipped with the dryer.

## J. PREPARATION FOR OPERATION / START-UP

The following items **should be** checked before attempting to operate the dryer:

1. Read **ALL** “CAUTION,” “WARNING,” and “DIRECTION” labels attached to the dryer.
2. Check incoming supply voltage to be sure that it is the same as indicated on the dryer data label.
3. **GAS MODELS** – Check to ensure that the dryer is connected to the type of heat/gas indicated on the dryer data label.
4. **GAS MODELS** – The sail switch damper assembly was installed and adjusted at the factory prior to shipping. However, each sail switch adjustment **must be** checked to ensure that this important safety control is functioning.
5. **GAS MODELS** – Be sure that **ALL** gas shutoff valves are in the open position.
6. Be sure **ALL** side and base panels are on the dryer.
7. Check **ALL** service doors to ensure that they are closed and secure.
8. Be sure lint drawer is securely in place.

**NOTE: LINT DRAWER *MUST BE* ALL THE WAY IN PLACE TO ACTIVATE SAFETY SWITCH, OTHERWISE THE DRYER WILL NOT START.**

9. Rotate the basket (tumbler/drum) by hand to be sure it moves freely.
10. Check bolts, nuts, screws, terminals, and fittings for security.
11. Check to ensure air supply (80 psi [5.51 bar]) is connected to the dryer.
12. **STEAM MODELS** – Check to ensure **ALL** steam shutoff valves are open.

## **K. SHUT DOWN INSTRUCTIONS**

If the dryer is to be shut down (taken out of service) for a period of time, the following **must be** performed:

1. Discontinue power to the dryer either at the external disconnect switch or the circuit breaker.
2. Discontinue the heat supply:
  - a. **GAS MODELS** – **discontinue the gas supply.**
    - 1) **SHUT OFF external gas supply shutoff valve.**
    - 2) **SHUT OFF internal gas supply shutoff valve located in the gas valve burner area.**
  - b. **STEAM MODELS** – **discontinue steam supply.**
    - 1) **SHUT OFF external (location furnished) shutoff valve.**
    - 2) **SHUT OFF internal steam valves in the supply lines and the return lines.**



# SECTION IV

## SERVICE / PARTS INFORMATION

### A. SERVICE

Service **must be** performed by a qualified trained technician, service agency, or gas supplier. If service is required, contact the reseller from whom the **ADC** equipment was purchased. If the reseller **cannot** be contacted or is unknown, contact the **ADC** Service Department for a reseller in your area.

**NOTE:** When contacting the **ADC** Service Department, be sure to give them the correct **model number** and **serial number** so that your inquiry is handled in an expeditious manner.

### B. PARTS

Replacement parts **should be** purchased from the reseller from whom the **ADC** equipment was purchased. If the reseller **cannot** be contacted or is unknown, contact the **ADC** Parts Department for a reseller in your area. Parts may also be purchased directly from the factory by calling the **ADC** Parts Department at +1 (508) 678-9000 or you may FAX in your order at +1 (508) 678-9447.

**NOTE:** When ordering replacement parts from the **ADC** reseller or the **ADC** factory be sure to give them the correct **model number** and **serial number** so that your parts order can be processed in an expeditious manner.

# SECTION V

## WARRANTY INFORMATION

### A. RETURNING WARRANTY CARDS

Before any dryer leaves the **ADC** factory test area, a warranty card is placed on the back side of the main door glass. These warranty cards are intended to serve the customer where we record the individual installation date and warranty information to better serve you should you file a warranty claim.

If a warranty card did not come with your dryer, contact the **ADC** Warranty Department or **ADC** Service Department at +1 (508) 678-9000.

**IMPORTANT:** A separate warranty card *must be* completed and returned for each individual dryer.

**NOTE:** Be sure to include the installation date when returning the warranty card(s).

### B. WARRANTY

For a copy of the **ADC** commercial warranty covering your particular dryer(s), contact the **ADC** reseller from whom you purchased the equipment and request a dryer warranty form. If the reseller **cannot** be contacted or is unknown, warranty information can be obtained from the factory by contacting the **ADC** Warranty Department at +1 (508) 678-9000.

**NOTE:** Whenever contacting the **ADC** factory for warranty information, be sure to have dryer's **model number** and **serial number** available so that your inquiry can be handled in an expeditious manner.

### C. RETURNING WARRANTY PARTS

**ALL** dryer or parts warranty claims or inquiries **should be** addressed to the **ADC** Warranty Parts Department at +1 (508) 678-9000. To expedite processing, the following procedures **must be** followed:

1. No parts are to be returned to **ADC** without prior written authorization ("Return Material Authorization" [R.M.A.]) from the factory.

**NOTE:** An R.M.A. is valid for only thirty (30) days from date of issue.

The R.M.A. issued by the factory, as well as any other correspondence pertaining to the returned part(s), **must be** included inside the package with failed merchandise.

2. Each part **must be** tagged with the following information:
  - a. **Model number** and **serial number** of the dryer from which the part was removed.
  - b. Nature of failure (be specific).
  - c. Date of dryer installation.
  - d. Date of part failure.
  - e. Specify whether the part(s) being returned is for a replacement, a credit, or a refund.

**NOTE:** If a part is marked for a credit or refund, the invoice number covering the purchase of the replacement part ***must be*** provided.

**NOTE:** Warranty tags (ADC P/N 450064) are available at “no charge” from ADC upon request.

3. The company returning the part(s) must clearly note the complete company name and address on the outside of the package.
4. **ALL** returns **must be** properly packaged to ensure that they are not damaged in transit. *Damage claims are the responsibility of the shipper.*

**IMPORTANT:** No replacements, credits, or refunds **will be** issued for merchandise damaged in transit.

5. **ALL** returns **should be** shipped to the ADC factory in such a manner that they are insured and a proof of delivery can be obtained by the sender.
6. **Shipping charges are not the responsibility of ADC. ALL returns should be “prepaid” to the factory. Any “C.O.D.” or “COLLECT” returns will not be accepted.**

**IMPORTANT:** No replacements, credits, or refunds **will be** issued if the claim **cannot** be processed due to insufficient information. The party filing the claim **will be** notified in writing, either by “FAX” or “CERTIFIED MAIL” – Return Receipt Requested,” as to the information necessary to process claim. If a reply **is not** received by the ADC Warranty Department within thirty (30) days from the FAX/letter date, then no replacements, credits, or refunds **will be** issued, and the merchandise **will be discarded**.

# SECTION VI

## ROUTINE MAINTENANCE

### A. CLEANING

A program and/or schedule **should be** established for periodic inspection, cleaning, and removal of lint from various areas of the dryer, as well as throughout the ductwork system. The frequency of cleaning can best be determined from experience at each location. Maximum operating efficiency is dependent upon proper air circulation. The accumulation of lint can restrict this airflow. If the guidelines in this section are met, an **ADC** dryer will provide many years of efficient, trouble free, and most importantly, safe operation.

**WARNING: LINT FROM MOST FABRICS IS HIGHLY COMBUSTIBLE. THE ACCUMULATION OF LINT CAN CREATE A POTENTIAL FIRE HAZARD.**

**WARNING: KEEP DRYER AREA CLEAN AND FREE FROM COMBUSTIBLE MATERIALS, GASOLINE, AND OTHER FLAMMABLE VAPORS AND LIQUIDS.**

**NOTE:** Suggested time intervals shown are for average usage, which is considered six (6) to eight (8) operational (running) hours a day.

**IMPORTANT:** This dryer produces combustible lint and **must be** exhausted to the outdoors. Every 6 months, inspect the exhaust ducting and remove any lint buildup.

### CLEANING SCHEDULE

#### ***EVERY THIRD OR FOURTH LOAD***

Clean the lint basket. A clogged lint basket will cause poor dryer performance. The lint basket is located in the lint drawer in the base of the dryer. Pull out the lint drawer, brush the lint off the basket, and remove the lint. Inspect lint basket assembly and replace if torn.

**NOTE:** Frequency of cleaning lint basket can best be determined at each location.

#### ***WEEKLY***

Remove side panels on each side of the basket (tumbler) section and remove any lint accumulation, from the basket (tumbler) drive motor, drive shafts, gear reducer, V-belts, drive wheels, and drive shaft bearings.

Slide the lint basket **ALL** the way out of the dryer and clean any lint accumulation off of the temperature sensor bracket, which is located above the lint basket.

**WARNING: TO AVOID THE HAZARD OF ELECTRICAL SHOCK, DISCONTINUE ELECTRICAL SUPPLY TO THE DRYER.**

## **MONTHLY**

Empty the compressed air filter bowl.

## **EVERY 3 MONTHS**

Clean lint accumulation from the gas valve/burner area at the top of the dryer, the fan (impellor) motor, and the fan/impellor bearings located in the dryer's base.

**NOTE:** To prevent damage, avoid cleaning and/or touching ignitor/flame-probe assembly.

## **EVERY 6 MONTHS**

Check fan (impellor) and drive motor V-belts for tightness and wear. Retighten and replace if required.

**STEAM MODELS** – Clean the steam coil fins. We suggest using compressed air and a vacuum cleaner with brush attachment.

**NOTE:** When cleaning steam coil fins, be careful not to bend the fins. If fins are bent, straighten by using a fin comb, which is available from local air-conditioning supply houses.

Inspect and remove lint accumulation in customer furnished exhaust ductwork system and from dryer's internal exhaust ducting.

**CAUTION: THE ACCUMULATION OF LINT IN THE EXHAUST DUCTWORK CAN CREATE A POTENTIAL FIRE HAZARD.**

**NOTE: DO NOT OBSTRUCT THE FLOW OF COMBUSTION AND VENTILATION AIR. CHECK CUSTOMER FURNISHED BACK DRAFT DAMPERS IN THE EXHAUST DUCTWORK. INSPECT AND REMOVE ANY LINT ACCUMULATION, WHICH CAN CAUSE THE DAMPER TO BIND OR STICK.**

**NOTE:** When cleaning the dryer cabinet(s), avoid using harsh abrasives. A product intended for the cleaning of appliances is recommended.

## B. ADJUSTMENTS

### ***7 DAYS AFTER INSTALLATION AND EVERY 6 MONTHS THEREAFTER***

Inspect bolts, nuts, screws, setscrews, grounding connections, and nonpermanent gas connections (unions, shutoff valves, and orifices). Motor and drive belts **should be** examined. Cracked or seriously frayed belts **should be** replaced. Tighten loose V-belts when necessary. Complete operational check of controls and valves. Complete operational check of **ALL** safety devices (door switch, lint drawer switch, sail switch, burner, and hi-limit thermostats).

### ***30 DAYS AFTER INSTALLATION***

**SHUT OFF ALL POWER TO THE DRYER.** Verify that the electrical connections to the motor contactors and overloads are tight. This is done to accommodate the compression of the wires over time.

### ***YEARLY***

**WARNING:** Twisting of the gas line may cause premature failure.

Inspect flex gas lines for leaks; if any signs of fraying or abrasion are found, the gas line **must be** replaced.

## C. LUBRICATION

### ***MONTHLY***

The two (2) bearings that support the impellor/fan shaft **must be** lubricated. Use Shell Alvania #2 grease or its equivalent. Generically, this grease would be described as an NLGI Grade 2 multipurpose industrial grease with a lithium thickener and mineral base oil.

### ***EVERY 3 MONTHS***

The four (4) bearings that support the drive and idler shafts **must be** lubricated. Use Shell Alvania #2 grease or its equivalent. Generically, this grease would be described as an NLGI Grade 2 multipurpose industrial grease with a lithium thickener and mineral base oil.

# SECTION VII

## MANUAL RESET BURNER HI-LIMIT INSTRUCTIONS

This dryer was manufactured with a manual reset burner hi-limit thermostat, which is monitored by the Phase 7 computer. If the burner hi-limit is open prior to the start of the drying cycle, the dryer will start momentarily and then shut down, the Phase 7 computer will display “burner HIGH LIMIT fault” with an audio indication.

If the burner hi-limit opens during a drying cycle, the Phase 7 computer will also display the same error code described above, along with an audio indication. If the drum temperature is above 100° F (38° C), the dryer will continue to run with no heat for 3 minutes or until the drum temperature has dropped below 100° F (38° C). The clear/stop button on the Phase 7 keyboard (touch pad) **must be** pressed to clear the error condition. The open burner hi-limit **must be** reset “manually” prior to the start of the next cycle.

**WARNING:** Discontinue power to dryer before attempting to reset hi-limit.

### IMPORTANT IMPORTANT IMPORTANTE

HEATING UNIT IS EQUIPPED WITH A HI-LIMIT THERMOSTAT WHICH *MUST BE RESET MANUALLY.*

WARNING - DISCONTINUE POWER TO DRYER BEFORE ATTEMPTING TO RESET HI-LIMIT.

L'ÉLÉMENT CHAUFFANT EST ÉQUIPÉ D'UN THERMOSTAT À LIMITE MAXIMALE QUI *DOIT ÊTRE RÉGLÉ MANUELLEMENT.*

MISE EN GARDE - COUPER LE COURANT D' ALIMENTATION DU SÈCHE-LINGE AVANT DE RÉGLER LA LIMITE MAXIMALE.

LA UNIDAD DE CALENTAMIENTO ESTÁ EQUIPADA CON UN TERMOSTATO DE LÍMITE SUPERIOR *QUE DEBE REINICIARSE MANUALMENTE.*

ADVERTENCIA - DESCONNECTE LA ALIMENTACIÓN ELÉCTRICA A LA SECADORA ANTES DE REINICIAR EL LÍMITE SUPERIOR.

ADC P/N: 114076





# SECTION IX

## PROCEDURE FOR FUNCTIONAL CHECK

### OF REPLACEMENT COMPONENTS

#### 1. For Models with Direct Spark Ignition (DSI) Module (Type I)

Theory of Operation:

Start the drying cycle. When the gas burner ignites within the chosen trial for ignition time (6-seconds), the flame sensor detects gas burner flame and signals the DSI module to keep the gas valve open as long as there is a call for heat. The DSI module will “LOCKOUT” if the gas burner flame is not sensed at the end of the trial for ignition period. The trial for ignition period will be repeated for a total of three (3) retries/trials (the initial try and two [2] more retries/trials). If the flame is not sensed at the end of the third retry/trial (inter-purge period of 30-seconds), the DSI module will “LOCKOUT” (light emitting diode [L.E.D.] diagnostic indicator flashes).

A steady L.E.D. indicator indicates normal operation.

No L.E.D. indicator indicates a power or an internal failure has occurred.

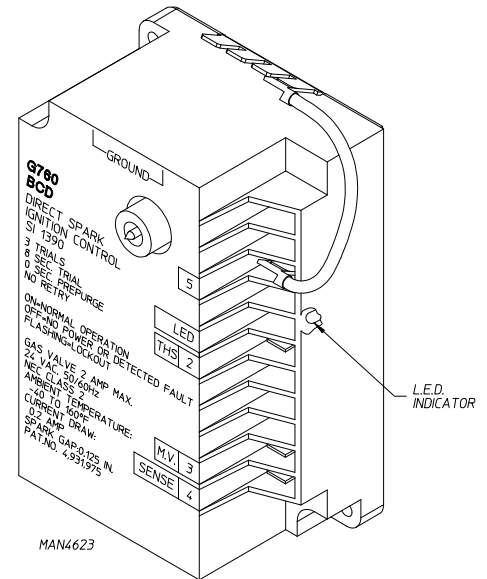

# SECTION X

## SUPPRESSION SYSTEM

The exclusive suppression system will extinguish fires that may start in the drying basket (tumbler). A series of sensors positioned throughout the basket (tumbler) and interfaced with the microprocessor controller (computer) will trigger the suppression system water jets to extinguish the flames quickly. The water jets remain on for 2 minutes and will automatically activate again if a fire condition remains or reignites. While the water jets are activated, the basket (tumbler) will jog to move the water throughout the load. Until the dryer is attended to, the microprocessor controller (computer) will display that the system was activated.

**NOTE:** It is recommended that a filter or strainer be installed in the water supply (feed) line.

### BEFORE YOU START!

#### CHECK LOCAL CODES AND PERMITS

Call your local water company or the proper municipal authority for information regarding local codes.

**IMPORTANT:** It is your responsibility to have ALL plumbing connections made by a qualified professional to assure that the plumbing installation is adequate and conforms to local, state, and federal regulations or codes.

**IMPORTANT:** It is the installation or owner's responsibility to see that the required water, water pressure, pipe size, and connections are provided. The manufacturer assumes no responsibility if the suppression system is not connected, installed, or maintained properly.

**WARNING:** The suppression system will become INOPERATIVE if water is not supplied.

**WARNING:** ELECTRICAL POWER ***MUST BE*** PROVIDED TO THE DRYER AT ALL TIMES. If the main electrical power supply to the dryer is disconnected, the suppression system is INOPERATIVE!!

# INSTALLATION

## 1. Requirements

The connection point for the suppression system is a 3/4" F.N.P.T. port. The suppression system **must be** supplied with a minimum water pipe size of 1/2" and be provided with a minimum of 40 psi (2.75 bar) and a maximum of 100 psi (6.89 bar) of pressure. For use of optional manual bypass, a second source with the same piping and pressure requirements is required.

**IMPORTANT:** Flexible supply (feed) line/coupling **must be** used. Solenoid valve failure due to hard plumbing connections will VOID THE WARRANTY.

If the rear area of the dryer or the water supply is located in an area where it will be exposed to cold/freezing temperatures, provisions **must be** made to protect these water lines from freezing.

**WARNING:** If the water in the supply (feed) line or water solenoid valve freezes, the suppression system **will be** INOPERATIVE!!

## 2. Water Connections:

The water connection is made to the 3/4" F.N.P.T. port located on the right hand side of the dryer base.

### TYPICAL WATER SUPPLY...

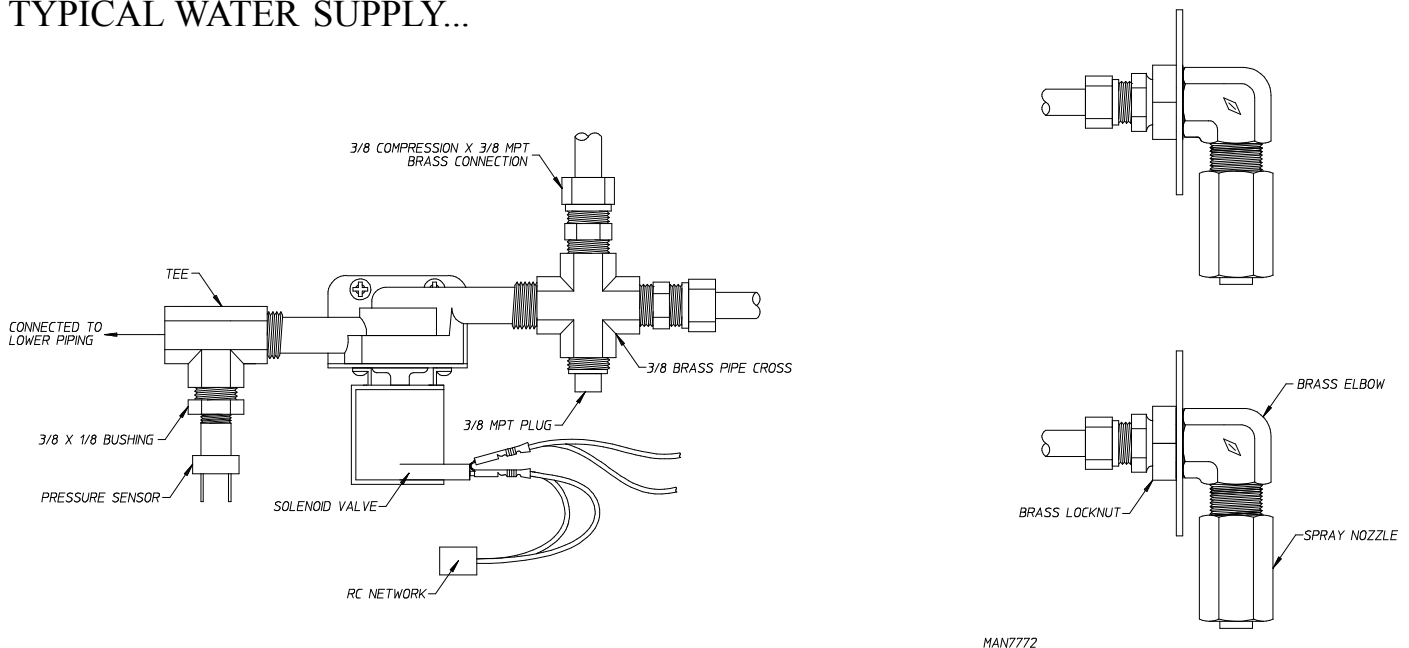

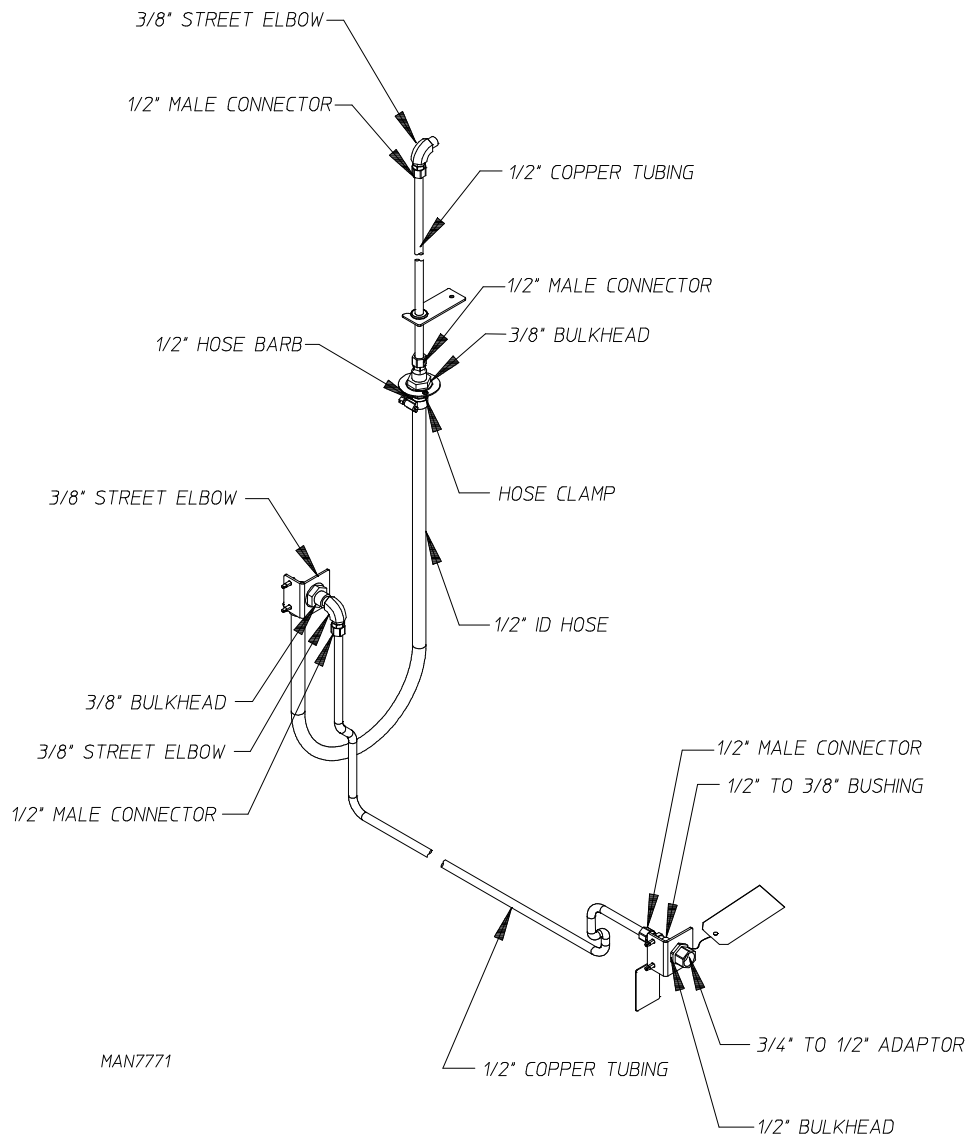

MAN7771

**WARNING:** The suppression system will become INOPERATIVE if water **is not** supplied.

**IMPORTANT:** Flexible supply (feed) line/coupling **must be** used. Solenoid valve failure due to hard plumbing connections will **VOID THE WARRANTY**. **It is recommended** that a filter or strainer be installed in the water supply (feed) line. (For non-tilt models only.)

## OPTIONAL MANUAL BYPASS

Provisions are made in the dryer's suppression system for the installation of an optional manual bypass. Depending on the model dryer, the connections for the manual bypass are made at the "T" or "four way" fitting located in the outlet supply side of the water solenoid valve. The use and connections of this manual bypass are at the option or discretion of the owner.

The water connection for the manual bypass is made to the "T" or "four way" fitting, which has a 3/8" F.P.T. and a coupling **must be** used to provide the minimum 1/2" supply (feed) line.

If the rear area of the dryer or the water supply is located in an area where it will be exposed to cold/freezing temperatures, provisions **must be** made to protect these water lines from freezing.

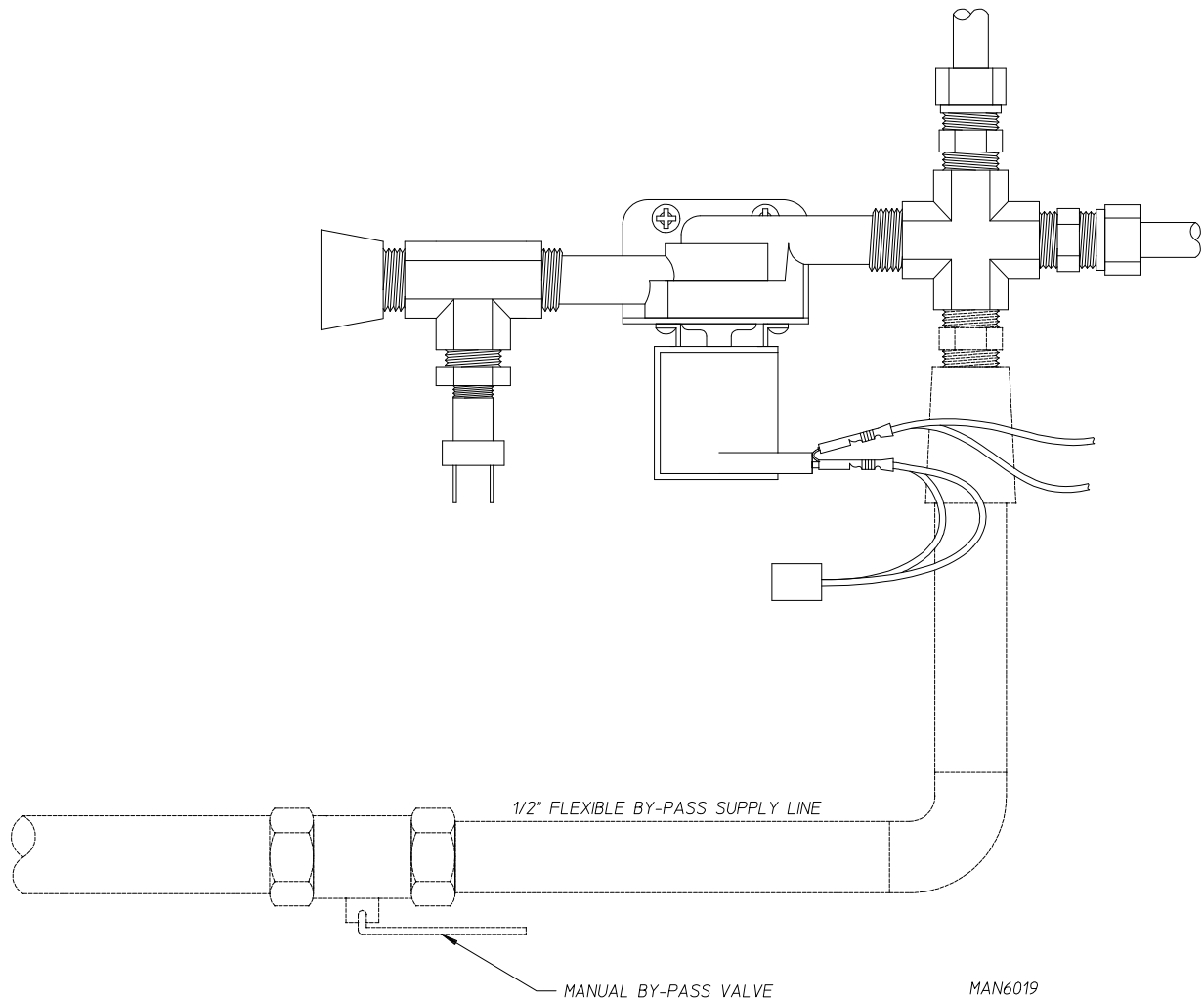

DMG 12/3/01

MANUAL BY-PASS VALVE

MAN6019

**WARNING:** If the water in the supply (feed) line or water solenoid valve freezes, the suppression system **will be** INOPERATIVE!!

The manual ball cock shutoff valve **must be** located outside of the dryer at a distance from the dryer where it is easily accessible.

### 3. Electrical Requirements

No independent external power source or supply connection is necessary. The 24-volt power to operate the suppression system is accomplished internally in the dryer (from the dryer controls).

**WARNING:** ELECTRICAL POWER **MUST BE** PROVIDED TO THE DRYER AT **ALL** TIMES. If the main electrical power supply to the dryer is disconnected, the suppression system is INOPERATIVE!!

# Theory of Operation

20-seconds after the heat turns off, the Phase 7 microprocessor controller (computer) monitors the suppression system probe located in the top of the basket (tumbler) chamber and records the minimum temperature. If the minimum recorded temperature is no less than 120° F (48° C) and the microprocessor controller (computer) detects a 35° rise in temperature, this will be the trip point and the suppression system routine will activate.

While a drying cycle is in process and the heat is on, the Phase 7 microprocessor controller (computer) monitors the exhaust temperature transducer. If the drying cycle temperature set point is set greater than 160° F (71° C) and the microprocessor controller (computer) detects an exhaust temperature rise 25° F greater than set point, this will be the trip point and the suppression system routine will activate.

Once the suppression system routine is activated, water will be injected into the basket (tumbler) chamber. Anytime water is being injected into the basket (tumbler), the basket (tumbler) drive will turn the load for 1-second every 15-seconds. This process will continue for a minimum of 2 minutes. After 2 minutes has elapsed, the microprocessor controller (computer) will check if the temperature remained above trip point, if so water will remain on. The microprocessor controller (computer) will continue to check if temperature is above trip point every 30-seconds. If the water has been on for a constant 10 minutes, the water will be turned off regardless of the temperature. If the temperature has dropped below trip point, the microprocessor controller (computer) will turn off the water prior to 10 minutes.

## SYSTEM RESET



After the microprocessor controller (computer) determines that the situation is under control and shuts off the water being injected into the basket (tumbler), the microprocessor controller (computer) display will read "...SUPPRESSION SYSTEM ACTIVATED", and the audio alert tone will sound until reset manually.

To reset the microprocessor controller (computer) and the suppression system, press the red "STOP/CLEAR"  key on the keyboard (touch pad).

## NON-COIN SUPPRESSION SYSTEM CHECK PROCEDURE

The operation of the water solenoid valve **should be** tested to ensure that the water supply system and valve are functional. Before attempting system check, be sure that **ALL** water supply shutoff valves to the dryer are in the OPEN position, and the dryer **must be** in the "READY" mode (where no cycle is loaded or in progress).

**IMPORTANT:** This is a test function only and the keys **should be** held and system activated for only a second or so, otherwise water will accumulate in various places in the dryer.

The suppression system water solenoid valve test can be performed by pressing the red "STOP/CLEAR"  key and the  key together. The water valve will open and water will be dispensed into basket (tumbler) area as long as both keys are held.



