

# AD-24 Installation Manual

## Phase 7 / Dual Timer / S.A.F.E. System

**WARNING:** For your safety the information in this manual must be followed to minimize the risk of fire or explosion and to prevent property damage, personal injury or death.

- Do not store or use gasoline or other flammable vapors and liquids in the vicinity of this or any other appliance.
- **WHAT TO DO IF YOU SMELL GAS:**
  - Do not try to light any appliance.
  - Do not touch any electrical switch; do not use any phone in your building.
  - Clear the room, building or area of all occupants.
  - Immediately call your gas supplier from a neighbor's phone. Follow the gas supplier's instructions.
  - If you cannot reach your gas supplier, call the fire department.
- Installation and service must be performed by a qualified installer, service agency or the gas supplier.

**AVERTISSEMENT:** Assurez-vous de bien suivre les instructions données dans cette notice pour réduire au minimum le risque d'incendie ou d'explosion ou pour éviter tout dommage matériel, toute blessure ou la mort.

- Ne pas entreposer ni utiliser d'essence ni d'autres vapeurs ou liquides inflammables à proximité de cet appareil ou de tout autre appareil.
- **QUE FAIRE SI VOUS SENTEZ UNE ODEUR DE GAZ:**
  - Ne pas tenter d'allumer d'appareils.
  - Ne touchez à aucun interrupteur. Ne pas vous servir des téléphones se trouvant dans le bâtiment.
  - Évacuez la pièce, le bâtiment ou la zone.
  - Appelez immédiatement votre fournisseur de gaz depuis un voisin. Suivez les instructions du fournisseur.
  - Si vous ne pouvez rejoindre le fournisseur de gaz, appelez le service des incendies.
- L'installation et l'entretien doivent être assurés par un installateur ou un service d'entretien qualifié ou par le fournisseur de gaz.



### American Dryer Corporation

88 Currant Road  
Fall River MA 02720-4781 USA  
Telephone: +1 (508) 678-9000 / Fax: +1 (508) 678-9447  
e-mail: techsupport@amdry.com

[www.adclaundry.com](http://www.adclaundry.com)

# Retain This Manual in a Safe Place for Future Reference

This product embodies advanced concepts in engineering, design, and safety. If this product is properly maintained, it will provide many years of safe, efficient, and trouble free operation.

Only qualified technicians should service this equipment.

OBSERVE ALL SAFETY PRECAUTIONS displayed on the equipment or specified in the installation manual included with the dryer.

The following "FOR YOUR SAFETY" caution must be posted near the dryer in a prominent location.

**FOR YOUR SAFETY**

Do not store or use gasoline or other flammable vapors and liquids in the vicinity of this or any other appliance.

**POUR VOTRE SÉCURITÉ**

Ne pas entreposer ni utiliser d'essence ni d'autres vapeurs ou liquides inflammables à proximité de cet appareil ou de tout autre appareil.

We have tried to make this manual as complete as possible and hope you will find it useful. The manufacturer reserves the right to make changes from time to time, without notice or obligation, in prices, specifications, colors, and material, and to change or discontinue models. The illustrations included in this manual may not depict your particular dryer exactly.

## IMPORTANT

For your convenience, log the following information:

**DATE OF PURCHASE** \_\_\_\_\_ **MODEL NO.** **AD-24**

**RESELLER'S NAME** \_\_\_\_\_

**SERIAL NUMBER(S)** \_\_\_\_\_

Replacement parts can be obtained from your reseller or the ADC factory. When ordering replacement parts from the factory, you can FAX your order to ADC at +1 (508) 678-9447 or telephone your order directly to the ADC Parts Department at +1 (508) 678-9000. Please specify the dryer model number and serial number in addition to the description and part number, so that your order is processed accurately and promptly.

These instructions are only valid if the following country code is on the appliance... If this code is not present on the appliance, it is necessary to refer to the technical instructions which will provide the necessary information concerning the modification of the appliance to the condition of use for the country.

In accordance with EN ISO 3166-1, the names of countries shall be represented by the following codes:

**GB** United Kingdom  
**IE** Ireland

**"IMPORTANT NOTE TO PURCHASER"**

Information must be obtained from your local gas supplier on the instructions to be followed if the user smells gas. These instructions must be posted in a prominent location near the dryer.

# ⚠ WARNING

## Proposition 65

**Use of this product could expose you to substances from fuel combustion that contain chemicals known to the State of California to cause cancer, birth defects and other reproductive harm.**

### IMPORTANT

You must disconnect and lockout the electric supply and the gas supply or the steam supply before any covers or guards are removed from the machine to allow access for cleaning, adjusting, installation, or testing of any equipment per OSHA standards.

Please observe all safety precautions displayed on the equipment and/or specified in the installation manual included with the dryer.

### CAUTION

Dryer(s) should never be left unattended while in operation.

“Caution: Label all wires prior to disconnection when servicing controls. Wiring errors can cause improper operation.”

«Attention: Au moment de l'entretien des commandes, étiquetez tous les fils avant de les débrancher. Des erreurs de câblage peuvent entraîner un fonctionnement inadéquat et dangereux.»

### WARNING

Children should not be allowed to play on or near the dryer(s). Children should be supervised if near dryer(s) in operation.

Under no circumstances should the dryer door switch, lint door switch, or heat safety circuit ever be disabled.

Do not modify this appliance.

The dryer must never be operated with any of the back guards, outer tops, or service panels removed. Personal injury or fire could result.

The dryer must never be operated without the lint filter/screen in place, even if an external lint collection system is used.

### FOR YOUR SAFETY

Do not dry mop heads in the dryer. Do not use dryer in the presence of dry cleaning fumes.

The dryers must not be installed or stored in an area where it will be exposed to water and/or weather.

The wiring diagram for the dryer is located in the front electrical control box area.

In the State of Massachusetts, the following installation instructions apply:

- Installations and repairs must be performed by a qualified or licensed contractor, plumber, or gasfitter qualified or licensed by the State of Massachusetts.
- If using a ball valve, it shall be a T-handle type.
- A flexible gas connector, when used, must not exceed 3 feet.

## Table of Contents

Safety Precautions .....	4
Specifications .....	5
Installation Procedures .....	7
Unpacking / Setting Up .....	7
Dryer Enclosure Requirements .....	7
Fresh Air Supply Requirements .....	8
Exhaust Requirements .....	8
Electrical Information .....	11
Gas Information .....	14
Preparation for Operation / Start-Up .....	15
Preoperational Test .....	15
Preoperational Instructions .....	16
Shutdown Instructions .....	17
Service / Parts Information .....	17
Service .....	17
Parts .....	17
Warranty Information .....	17
Returning Warranty Cards .....	17
Warranty .....	17
Returning Warranty Parts .....	17
Routine Maintenance .....	18
Cleaning .....	18
Adjustments .....	19
Lubrication .....	19
Data Label Information .....	19
Procedure for Functional Check .....	19
S.A.F.E. System .....	21
Non-Coin Programming .....	24
Coin Programming .....	25

## List of Acronyms

D.M.S.	Drill Measurement Size
DSI	Direct Spark Ignition
HVAC	Heating, Ventilating, and Air-Conditioning
in WC	Inches of Water Column
L.C.D.	Liquid Crystal Display
L.E.D.	Light Emitting Diode
L.P.	Liquid Propane
OSHA	Occupational Safety and Health Administration
R.M.A.	Return Material Authorization
S.A.F.E.	Sensor Activated Fire Extinguishing
UL	Underwriters Laboratory

## Safety Precautions \_\_\_\_\_

### WARNING

**For your safety, the information in this manual must be followed to minimize the risk of fire or explosion or to prevent property damage, personal injury, or loss of life.**

**The dryer must never be operated with any of the back guards, outer tops, or service panels removed. Personal injury or fire could result.**

Keep dryer area clear and free from combustible materials, gasoline, and other flammable vapors and liquids.

Do not spray aerosols in the vicinity of this appliance while it is in operation.

Purchaser/user should consult the local gas supplier for proper instructions to be followed in the event the user smells gas. The instructions should be posted in a prominent location.

#### What To Do If You Smell Gas:

- Do not try to light any appliance.
- Do not touch any electrical switch.
- Do not use any phone in your building.
- Clear the room, building, or area of all occupants.
- Immediately call your gas supplier from a neighbor's phone. Follow the gas supplier's instructions.
- If you cannot reach your gas supplier, call the fire department.

Installation and service must be performed by a qualified installer, service agency, or gas supplier.

Dryers must be exhausted to the outdoors.

Although the manufacturer produces a very versatile dryer, there are some articles that, due to fabric composition or cleaning method, should not be dried in it.

### WARNING

**Dry only water washed fabrics. Do not dry articles spotted or washed in dry cleaning solvents, combustible detergents, industrial chemicals, or "all purpose" cleaner. Explosion could result.**

**Do not dry rags or articles coated or contaminated with gasoline, kerosene, oil, paint, or wax. Explosion could result.**

**Do not dry mop heads. Contamination by wax or flammable solvents will create a fire hazard.**

**Do not use heat for drying articles that contain plastic, foam, sponge rubber, or similarly textured rubber materials. Drying in a heated tumbler may damage plastics or rubber and also may be a fire hazard.**

The possible presence of residual quantities of aggressive or decomposed chemicals in the load may produce damage to the machine and harmful fumes.

A program should be established for the inspection and cleaning of lint in the burner area, exhaust ductwork, and area around the back of the dryer. The frequency of inspection and cleaning can best be determined from experience at each location.

### WARNING

**The collection of lint in the burner area and exhaust ductwork can create a potential fire hazard.**

For personal safety, the dryer must be electrically grounded in accordance with local codes and/or the National Electrical Code ANSI/NFPA NO. 70-LATEST EDITION, or in Canada, the Canadian Electrical Codes Parts 1 & 2 CSA C22.1-1990 or LATEST EDITION.

**NOTE:** *Failure to electrically ground the dryer properly will void the warranty.*

Under no circumstances should the dryer door switch, lint door switch, or heat safety circuit ever be disabled.

### WARNING

**Personal injury or fire could result should the dryer door switch, lint door switch, or heat safety circuit ever be disabled.**

This dryer is not to be used in the presence of dry cleaning solvents or fumes.

Remove articles from the dryer as soon as the drying cycle has been completed.

### WARNING

**Articles left in the dryer after the drying and cooling cycles have been completed can create a fire hazard.**

**CAUTION:** **Label all wires prior to disconnection when servicing controls. Wiring errors cause improper and dangerous operation. Verify proper operation after servicing.**

Read and follow all caution and direction labels attached to the dryer.

For safety, proper operation, and optimum performance, the dryer must not be operated with a load less than sixty-six percent, 13 lb (5.89 kg) of its rated capacity.

### WARNING

**You must disconnect and lockout the electric supply and the gas supply or the steam supply before any covers or guards are removed from the machine to allow access for cleaning, adjusting, installation, or testing of any equipment per OSHA standards.**

**IMPORTANT:** *The dryer must be installed in a location/ environment, which the ambient temperature remains between 40° F (4.44° C) and 130° F (54.44° C).*

### CE ONLY

**IMPORTANT:** *This appliance must only be installed and operated in the country of destination indicated on the dryer's data plate. If the appliance is to be installed and operated in a country other than the one indicated on the data plate, a data plate amendment must be obtained from American Dryer Corporation.*

IEC335 applies.

# Specifications

MAXIMUM CAPACITY (DRY WEIGHT)		20 lb	<b>9.07 kg</b>	
TUMBLER DIAMETER		27-1/4"	<b>69.22 cm</b>	
TUMBLER DEPTH		24"	<b>60.96 cm</b>	
TUMBLER VOLUME		8.10 cu ft	<b>229.37 L</b>	
TUMBLER/DRIVE MOTOR		1/2 hp	<b>0.37 kW</b>	
BLOWER/FAN MOTOR		N / A		
DOOR OPENING (DIAMETER)		21-1/2"	<b>54.61 cm</b>	
DOOR SILL HEIGHT		28-1/3"	<b>71.91 cm</b>	
WATER CONNECTION*		3/4" F.N.P.T.		
DRYERS PER 20'/40' CONTAINER		14 / 30		
DRYERS PER 48'/53' TRUCK		42 / 48		
GAS	VOLTAGE AVAILABLE		120-480V 1,3ø 2,3,4w 50/60 Hz	
	APPROXIMATE NET WEIGHT		426 lb <b>193.23 kg</b>	
	APPROXIMATE SHIPPING WEIGHT		461 lb <b>209.11 kg</b>	
	AIRFLOW	60 Hz	400 cfm	<b>11.33 cmm</b>
		50 Hz	333 cfm	<b>9.44 cmm</b>
	HEAT INPUT		60,000 Btu/hr	<b>15,120 kcal/hr</b>
	EXHAUST CONNECTION (DIAMETER)		6"	<b>15.24 cm</b>
	COMPRESSED AIR CONNECTION		N / A	
	COMPRESSED AIR VOLUME		N / A	
INLET PIPE CONNECTION		1/2" M.N.P.T.		
ELECTRIC	VOLTAGE AVAILABLE		208-480V 1,3ø 2,3,4w 50/60 Hz	
	APPROXIMATE NET WEIGHT		426 lb <b>193.23 kg</b>	
	APPROXIMATE SHIPPING WEIGHT		461 lb <b>209.11 kg</b>	
	AIRFLOW	60 Hz	400 cfm	<b>11.33 cmm</b>
		50 Hz	333 cfm	<b>9.44 cmm</b>
	EXHAUST CONNECTION (DIAMETER)		6"	<b>15.24 cm</b>
	COMPRESSED AIR CONNECTION		N / A	
	COMPRESSED AIR VOLUME		N / A	
	OVEN SIZE			
		kW	Btu/hr	<b>kcal/hr</b>
	18	61,400	<b>15,500</b>	
	20	68,200	<b>17,200</b>	
	24	81,900	<b>20,600</b>	
STEAM	VOLTAGE AVAILABLE		N / A	
	APPROXIMATE NET WEIGHT			
	APPROXIMATE SHIPPING WEIGHT			
	AIRFLOW	60 Hz		
		50 Hz		
	STEAM CONSUMPTION			
	OPERATING STEAM PRESSURE			
	EXHAUST CONNECTION (DIAMETER)			
	COMPRESSED AIR CONNECTION			
	COMPRESSED AIR VOLUME			
	BOILER HORSEPOWER (NORMAL LOAD)			
SUPPLY CONNECTION				
RETURN CONNECTION				

Shaded areas are stated in metric equivalents

10/5/10

\* Water supply must be 40 psi +/- 20 psi (2.75 bar +/- 1.37 bar) for fire suppression system to operate properly.

**NOTE:** The manufacturer reserves the right to make changes in specifications at any time without notice or obligation.

# Specifications

## DRYER NOTES:

- ° DUCTWORK SIZE VARIES WITH INSTALLATION CONDITIONS.
- ° EXHAUST STATIC PRESSURE MUST BE NO LESS THAN 0 AND MUST NOT EXCEED 0.3" (0.74 MB) WATER COLUMN.

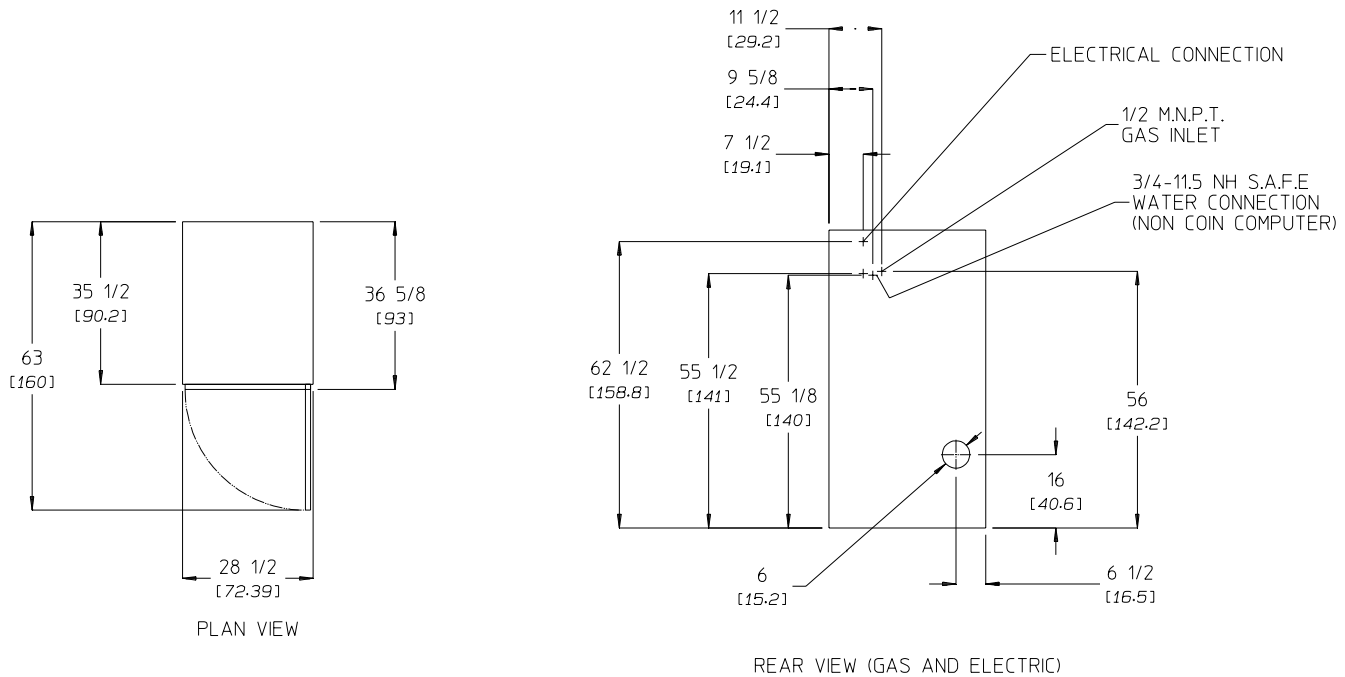

**NOTE:** The manufacturer reserves the right to make changes in specifications at any time without notice or obligation.

## Installation Procedures

Installation should be performed by competent technicians in accordance with local and state codes. In the absence of these codes, the installation must conform to applicable American National Standards: ANSI.Z223.1-LATEST EDITION (National Fuel Gas Code) or ANSI/NFPA NO. 70-LATEST EDITION (National Electrical Code) or in Canada, the installation must conform to Canadian Standards: CAN/CGA-B149.1-M91 (Natural Gas) or CAN/CGA-B149.2-M91 (L.P. Gas) or LATEST EDITION (for General Installation and Gas Plumbing) or Canadian Electrical Codes Parts 1 & 2 CSA C22.1-1990 or LATEST EDITION (for Electrical Connections).

### Unpacking / Setting Up

Remove protective shipping material (i.e., plastic wrap, and/or optional shipping box) from dryer.

The dryer can be moved to its final location while still attached to the skid or with the skid removed. To unskid the dryer, locate and remove the four bolts securing the base of the dryer to the wooden skid. Two are at the rear base (remove the back panel for access), and two are located in the bottom of the lint chamber. To remove the two bolts located in the lint chamber area, remove the lint door. Once the bolts are removed, slide the dryer off the skid.

With the skid removed, to make it easier to slide the dryer into its final position, slightly lower all four leveling legs, so that the dryer will slide on the legs instead of the base frame. The dryer is equipped with four leveling legs, one at each corner of the dryer base. Two are located at the rear of the dryer base, and two are located in the lint chamber.

To increase bearing life and improve efficiency, the dryer should be tilted slightly to the rear.

### Location of the Dryer

Before installing the dryer, be sure the location conforms to local codes and ordinances. In the absence of such codes or ordinances the location must conform with the National Fuel Gas Code ANSI.Z223.1 LATEST EDITION, or in Canada, the installation must conform to applicable Canadian Standards: CAN/CGA-B149.1-M91 (Natural Gas) or CAN/CGA-B149.2-M91 (L.P. Gas) or LATEST EDITION (for General Installation and Gas Plumbing).

The dryer must be installed on a sound level floor capable of supporting its weight. Carpeting must be removed from the floor area that the dryer is to rest on.

**IMPORTANT:** "The dryer must be installed on noncombustible floors only."

The dryer must not be installed or stored in an area where it will be exposed to water and/or weather.

The dryer is for use in noncombustible locations.

Provisions for adequate air supply must be provided as noted in this manual (refer to Fresh Air Supply Requirements section).

Clearance provisions must be made from noncombustible construction as noted in this manual (refer to Dryer Enclosure Requirements section).

Provisions must be made for adequate clearances for servicing and for operation as noted in this manual (refer to Dryer Enclosure Requirements section).

Dryer must be exhausted to the outdoors in an area where correct exhaust venting can be achieved as noted in this manual (refer to Exhaust Requirements section).

Dryer must be located in an area where correct exhaust venting can be achieved as noted in this manual (refer to Exhaust Requirements section).

**IMPORTANT:** Dryer should be located where a minimum amount of exhaust duct will be necessary.

The dryer must be installed with a proper exhaust duct connection to the outside.

The dryer must be installed with provisions for adequate combustion and make-up air supply.

**CAUTION:** This dryer produces combustible lint and must be exhausted to the outdoors. Every six months, inspect the exhaust ducting and remove any lint buildup.

**IMPORTANT:** Dryer must be installed in a location/environment, which the ambient temperature remains between 40° F (4.44° C) and 130° F (54.44° C).

### Dryer Enclosure Requirements

Bulkheads and partitions should be made of non-combustible materials and must be located a minimum of 12-inches (30.48 cm), 18-inches (45.72 cm) or more is recommended for ease of installation, maintenance, and service, above the dryer outer top, except along the front of the dryer, which may be closed in if desired. The clearance between the bulkhead header and the dryer must be a minimum of 4-inches (10.16 cm) and must not extend more than 4-inches (10.16 cm) to the rear of the front.

**NOTE:** Allowances must be made for opening the control door.

**IMPORTANT:** If the dryer is installed in a closet type enclosure there must be no other fuel burning appliance installed in the same closet.

Dryers may be positioned sidewall to sidewall. However, a 1/16" (1.5875 mm) minimum allowance must be made for opening and closing of the control door and the lint door. It is suggested that the dryer be positioned about 2 feet (0.61 meters) away from the nearest obstruction for ease of installation, maintenance, and service (to be measured from the back guard). Refer to the illustration below for details.

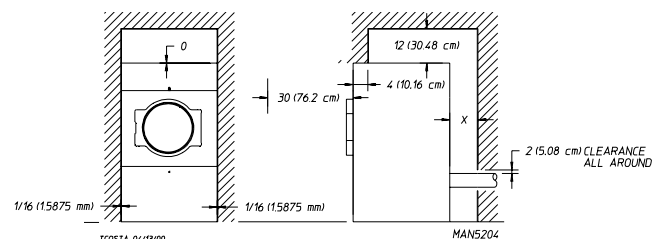

X = 12-inch (30.48 cm) minimum, 24-inches (60.96 cm) is suggested for ease of maintenance.

**NOTE:** Air considerations are important for proper and efficient operation.

## Fresh Air Supply Requirements

This appliance may only be installed in a room that meets the appropriate ventilation requirements specified in the national installation regulations.

Air supply (make-up air) must be given careful consideration to ensure proper performance of each dryer. An unrestricted source of air is necessary for each dryer. An airflow of 400 cfm (cubic feet per minute) (11.3 cmm [cubic meters per minutes]) must be supplied to each gas dryer. As a general rule, an unrestricted air entrance from the outdoors (atmosphere) of a minimum of 1 square foot (0.093 square meters) is required for each dryer. If registers or louvers are installed over the openings, then the area must be increased. It is not necessary to have separate make-up air openings for each dryer. Common make-up air openings are acceptable. However, they must be set up in such a manner that the make-up air is distributed equally to the dryers. The dryer must be installed with provisions for adequate combustion and make-up air supply.

**EXAMPLE:** For a bank of eight dryers, two unrestricted openings measuring 2 feet by 2 feet (0.61 meters by 0.61 meters) are acceptable.

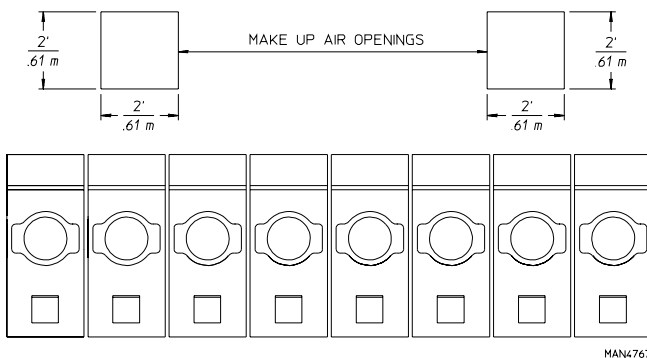

TYPICAL INSTALLATION SHOWING MAKE - UP AIR OPENINGS

**IMPORTANT:** Make-up air openings should not be located in an area directly near where exhaust vents exit the building.

Allowances must be made for remote or constricting passageways or where dryers are located at excessive altitudes or predominantly low pressure areas.

**IMPORTANT:** Make-up air must be provided from a source free of dry cleaning solvent fumes. Make-up air that is contaminated by dry cleaning solvent fumes will result in irreparable damage to the motors and other dryer components.

**NOTE:** Component failure due to dry cleaning solvent fumes will void the warranty.

## Exhaust Requirements

Exhaust ductwork should be designed and installed by a qualified professional. Improperly sized ductwork will create excessive back pressure, which results in slow drying, increased use of energy, overheating of the dryer, and shutdown of the burner by the airflow (sail) switches, burner hi-limits, or tumbler hi-limit thermostats. (Refer to the illustrations on the following page for details.) The dryer must be installed with a proper exhaust duct connection to the outside.

The design of the flue system shall be such that any condensate formed when operating the appliance from cold shall either be retained and subsequently re-evaporated or discharged.

**CAUTION:** This dryer produces combustible lint and must be exhausted to the outdoors.

**Improperly sized or installed exhaust ductwork can create a potential fire hazard.**

When possible, it is desirable to provide a separate exhaust air duct for each dryer. The duct should go as directly as possible to the outside air. Avoid sharp 90° right-angle turns in ducting; use 30° or 45° angles instead. The radius of the elbows should preferably be 1-1/2 times the diameter of the duct. To protect the outside end of the duct from the weather, it may be bent downwards as indicated on the following page. Leave at least twice the diameter of the duct as clearance between the duct opening and the nearest obstruction. If the exhaust duct goes through the roof, it may be protected from the weather by using a 180° turn to point the opening down. Allow at least twice the diameter of the duct as clearance from the nearest obstruction.

Do not use screens, louvers, or caps on the outside opening of the exhaust ductwork. The ducting should be smooth inside with no projections from sheet metal screws or other obstructions, which will collect lint. Additionally, inspection doors should be installed at strategic points in the exhaust ductwork for periodic inspection and cleaning.

Inadequate exhaust facilities may cause high temperature limit switches or airflow switches to shut off the dryers. Do not disable the switches, which are provided for your safety. Instead, investigate the exhaust ducting. Any obstruction or air friction due to numerous elbows/fittings in the ducting will slow the passage of air through the system with resulting inefficiency and potential fire hazard.

**IMPORTANT:** Exhaust back pressure measured by a manometer at the dryer's exhaust duct area must be no less than 0 and must not exceed 0.3 in WC (0.74 mb).

**NOTE:** When the exhaust ductwork passes through a wall, ceiling, or roof made of combustible materials, the opening must be 2-inches (5.08 cm) larger than the duct (all the way around). The duct must be centered within this opening.

**IMPORTANT:** The dryer exhaust duct must not be connected to any gas vent, chimney, wall, ceiling, or concealing space of a building.

It is recommended that exhaust or booster fans not be used in the exhaust ductwork system.

As per the National Fuel Gas Code, "Exhaust ducts for type 2 clothes dryers shall be constructed of sheet metal or other noncombustible material. Such ducts shall be equivalent in strength and corrosion resistance to ducts made of galvanized sheet steel not less than 26 gauge (0.0195-inches [0.50 mm]) thick."

## Single Dryer Venting

**IMPORTANT:** A minimum exhaust duct size of 6-inches (15.24 cm) must be used.

For a 6-inch (15.24 cm) horizontal run where a maximum of one elbow is used (refer to the illustration on the following page), the ductwork from the dryer outlet must not exceed 8 feet (2.44 meters).



HORIZONTAL SINGLE DRYER  
VENTING 6-INCH (15.24 cm) DUCTING

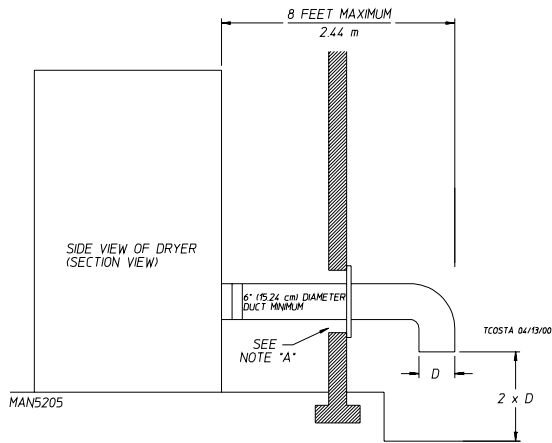

NOTE A: OPENING MUST BE 2-INCHES (5.08 cm) LARGER THAN THE DUCT (ALL THE WAY AROUND). THE DUCT MUST BE CENTERED WITHIN THIS OPENING.

If the length of the duct run or quantity of elbows used exceeds the above noted specifications, the cross-sectional area of the ductwork must be increased in proportion to the number of elbows or duct run added.

**IMPORTANT:** For extended ductwork runs, the cross section area of the ductwork can only be increased to an extent. When the ductwork approaches the maximum limits noted in this manual, a professional HVAC firm should be consulted for proper venting information.

When single 6-inch (15.24 cm) venting is used, for a horizontal run, the ductwork from the dryer to the outside outlet cannot exceed 8 feet (2.44 meters) in total length. This calculation of 8 feet (2.44 meters) compensates or allows for the use of a maximum of one elbow (which is the outside outlet protection). Refer to the illustration above.

Single Dryer Venting

**IMPORTANT:** A minimum exhaust duct size of 8-inches (20.32 cm) must be used.

For an 8-inch (20.32 cm) horizontal run where a maximum of one elbow is used (refer to the illustration below), the ductwork from the dryer outlet must not exceed 40 feet (12.2 meters).

HORIZONTAL SINGLE DRYER  
VENTING 8-INCH (20.32 cm) DUCTING

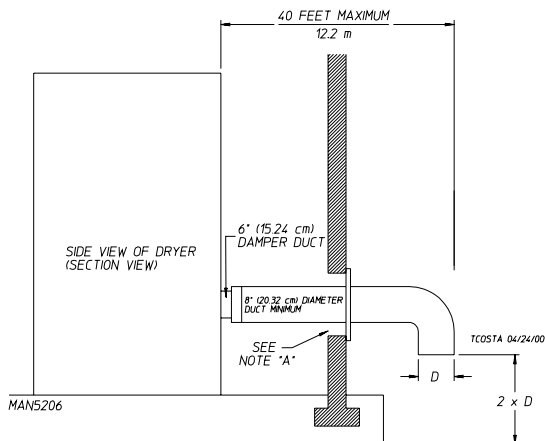

NOTE A: OPENING MUST BE 2-INCHES (5.08 cm) LARGER THAN THE DUCT (ALL THE WAY AROUND). THE DUCT MUST BE CENTERED WITHIN THIS OPENING.

If the length of the duct run or quantity of elbows used exceeds the above noted specifications, the cross-sectional area of the ductwork must be increased in proportion to the number of elbows or duct run added.

**IMPORTANT:** For extended ductwork runs, the cross section area of the ductwork can only be increased to an extent. When the ductwork approaches the maximum limits noted in this manual, a professional HVAC firm should be consulted for proper venting information.

When single 8-inch (20.32 cm) venting is used, for a horizontal run, the ductwork from the dryer to the outside outlet cannot exceed 40 feet (12.2 meters) in total length. This calculation of 40 feet (12.2 meters) compensates or allows for the use of a maximum of one elbow (which is the outside outlet protection). Refer to the previous illustration.

VERTICAL SINGLE DRYER  
VENTING 8-INCH (20.32 cm) DUCTING

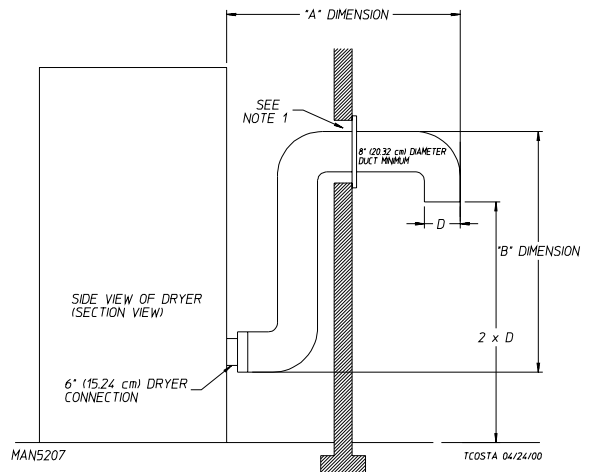

NOTE 1: OPENING MUST BE 2-INCHES (5.08 cm) LARGER THAN THE DUCT (ALL THE WAY AROUND). THE DUCT MUST BE CENTERED WITHIN THIS OPENING.

NOTE 2: "A" DIMENSION + "B" DIMENSION SHOULD NOT EXCEED 35 FEET (10.67 m) MAXIMUM.

When single 8-inch (20.32 cm) vertical venting is used (refer to the illustration below), the ductwork from the dryer to the outside outlet cannot exceed 35 feet (10.67 meters) in total length. This calculation of 35 feet (10.67 meters) compensates or allows for the use of a maximum of three elbows including the 180° (turned downward) outside outlet.

VERTICAL SINGLE DRYER VENTING

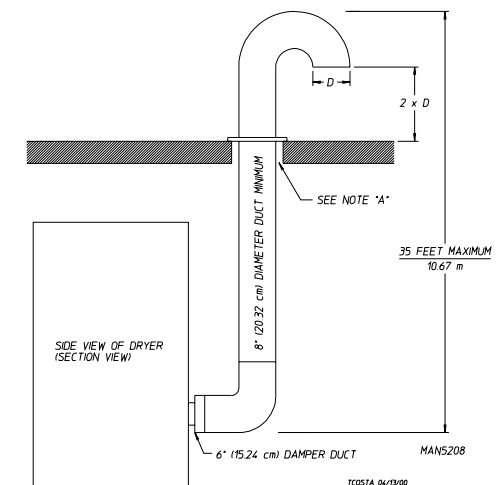

NOTE A: OPENING MUST BE 2-INCHES (5.08 cm) LARGER THAN THE DUCT (ALL THE WAY AROUND). THE DUCT MUST BE CENTERED WITHIN THIS OPENING.

MULTIPLE DRYER VENTING (HORIZONTAL)  
WITH A MINIMUM 8" (20.32 cm) DIAMETER EXHAUST  
CONNECTIONS AT COMMON DUCT

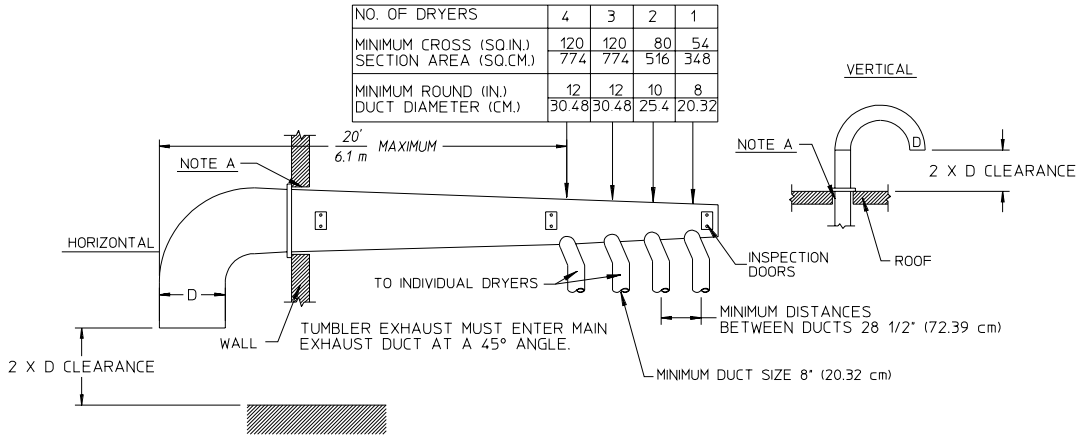

IMPORTANT: NO MORE THAN 4 DRYERS CAN BE CONNECTED TO ONE COMMON DUCT ( VENT ).

TCOSTA 04/13/00

MAN5209

FORMULAS TO CALCULATE DUCTING CROSS SECTIONAL AREA

CROSS SECTIONAL AREA OF A ROUND DUCT = .785 (19.939 mm) x D<sup>2</sup> WHERE D = DIAMETER OF THE DUCT.

CROSS SECTIONAL AREA OF A RECTANGULAR DUCT = W x H WHERE W = WIDTH AND H = HEIGHT.

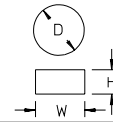

NOTE A: OPENING MUST BE 2-INCHES (5.08 cm) LARGER THAN DUCT (ALL THE WAY AROUND). THE DUCT MUST BE CENTERED WITHIN THIS OPENING.

MULTIPLE DRYER VENTING (VERTICAL) WITH A  
MINIMUM 8" (20.32 cm) DIAMETER EXHAUST CONNECTIONS AT COMMON DUCT

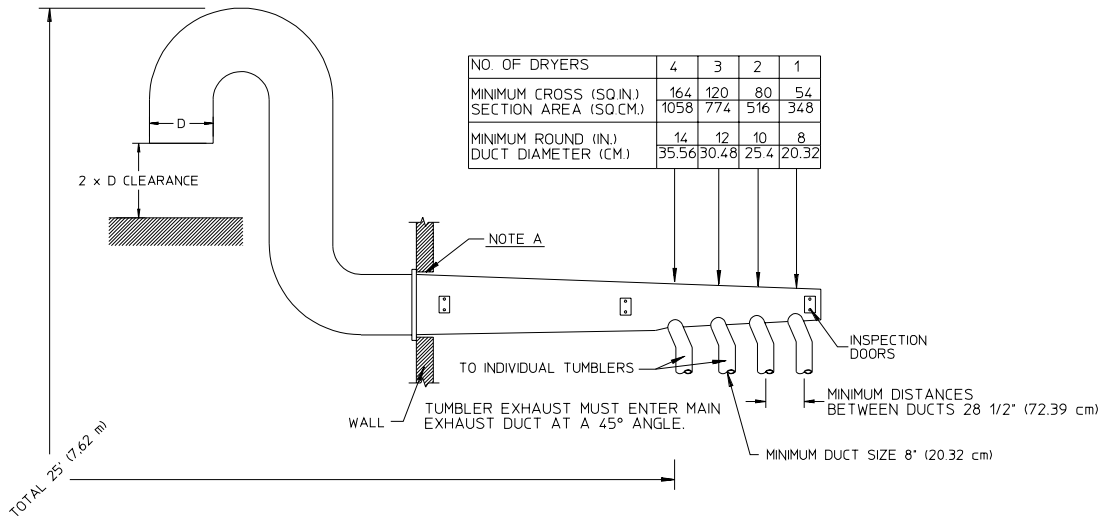

IMPORTANT: NO MORE THAN 4 DRYERS CAN BE CONNECTED TO ONE COMMON DUCT ( VENT ).

TCOSTA 04/13/00

MAN5210

FORMULAS TO CALCULATE DUCTING CROSS SECTIONAL AREA

CROSS SECTIONAL AREA OF A ROUND DUCT = .785 (19.939 mm) x D<sup>2</sup> WHERE D = DIAMETER OF THE DUCT.

CROSS SECTIONAL AREA OF A RECTANGULAR DUCT = W x H WHERE W = WIDTH AND H = HEIGHT.

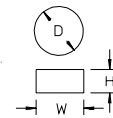

NOTE A: OPENING MUST BE 2-INCHES (5.08 cm) LARGER THAN DUCT (ALL THE WAY AROUND). THE DUCT MUST BE CENTERED WITHIN THIS OPENING.

**IMPORTANT:** For extended ductwork runs, the cross section area of the ductwork can only be increased to an extent. When the ductwork approaches the maximum limits as noted in this manual, a professional HVAC firm should be consulted for proper venting information.

Electrical Information  
Electrical Requirements

All electrical connections must be made by a properly licensed and competent electrician. This is to ensure that the electrical installation is adequate and conforms to local and state regulations or codes. In the absence of such codes, all electrical connections, materials, and workmanship must conform to the applicable requirements of the National Electrical Code ANSI/NFPA NO. 70-LATEST EDITION or in Canada, the Canadian Electrical Codes Parts 1 & 2 CSA C22.1-1990 or LATEST EDITION.

**IMPORTANT:** Failure to comply with these codes or ordinances, and/or the requirements stipulated in this manual can result in personal injury or component failure.

**NOTE:** Component failure due to improper installation will void the warranty.

Each dryer should be connected to an independently protected branch circuit. The dryer must be connected with copper wire only. Do not use aluminum wire, which could cause a fire hazard. The copper conductor wire/cable must be of proper ampacity and insulation in accordance with electric codes for making all service connections.

**NOTE:** The use of aluminum wire will void the warranty.

**IMPORTANT:** A separate protected circuit must be provided to each dryer.

**NOTE:** An individual ground circuit must be provided to each dryer, do not daisy chain.

**IMPORTANT:** The dryer must be connected to the electric supply shown on the data label. In the case of 208 VAC or 240 VAC, the supply voltage must match the electric service specifications of the data label exactly.

The wire size must be properly sized to handle the related current.

WARNING

**208 VAC and 240 VAC are not the same. Any damage done to dryer components due to improper voltage connections will automatically void the warranty.**

**NOTE:** Component failure due to improper voltage application will void the warranty.

The manufacturer reserves the right to make changes in specifications at any time without notice or obligation.

Electrical Service Specifications

**IMPORTANT:** Figures shown are for non-reversing models only. For reversing models contact the factory.

Gas Models Only

Gas					
ELECTRICAL SERVICE SPECIFICATIONS (PER DRYER)					
<b>IMPORTANT:</b> 208 VAC AND 230/240 VAC ARE NOT THE SAME. When ordering, specify exact voltage.					
<b>NOTES:</b> A. When fuses are used they must be dual element, time delay, current limiting, class RK1 or RK5 ONLY. Calculate/determine correct fuse value, by applying either local and/or National Electrical Codes to listed appliance amp draw data. B. Circuit breakers are thermal-magnetic (industrial) motor curve type ONLY. For others, calculate/verify correct breaker size according to appliance amp draw rating and type of breaker used. C. Circuit breakers for 3-phase (3ø) dryers must be 3-pole type.					
SERVICE VOLTAGE	PHASE	WIRE SERVICE	APPROX. AMP DRAW		CIRCUIT BREAKER
			60 Hz	50 Hz	
120	1ø	2	8.7	—	15
208	1ø	2	5.2	—	15
240	1ø	2	4.8	5.8	15
208	3ø	3	3	—	15
240	3ø	3	3.2	3.6	15
380-400	3ø	4 or 3	—	2.2	15
416	3ø	4 or 3	—	2.3	15
460 / 480	3ø	3	2.1	—	15

Check your national and local code for breaker and wire size 7/14/14

Electric Models Only

All electrically heated dryers must be connected to the electric service shown on the dryer's data label. The connecting wires must be properly sized to handle the rated current.

Electric					
ELECTRICAL SERVICE SPECIFICATIONS (PER DRYER)					
<b>IMPORTANT:</b> 208 VAC AND 230/240 VAC ARE NOT THE SAME. When ordering, specify exact voltage.					
<b>NOTES:</b> A. When fuses are used they must be dual element, time delay, current limiting, class RK1 or RK5 ONLY. Calculate/determine correct fuse value, by applying either local and/or National Electrical Codes to listed appliance amp draw data. B. Circuit breakers are thermal-magnetic (industrial) type ONLY. For others, calculate/verify correct breaker size according to appliance amp draw rating and type of breaker used. C. Circuit breakers for 3-phase (3ø) dryers must be 3-pole type.					
SERVICE VOLTAGE	PHASE	WIRE SERVICE	APPROX. AMP DRAW		CIRCUIT BREAKER
			60 Hz	50 Hz	
<b>18 kW</b>					
208	1ø	2	92	—	125
240	1ø	2	80	—	100
240	1ø	2	—	81	125
208	3ø	3	55	—	70
240	3ø	3	48	—	70

Check your national and local code for breaker and wire size 7/14/14

## Grounding

A ground (earth) connection must be provided and installed in accordance with state and local codes. In the absence of these codes, grounding must conform to applicable requirements of the National Electrical Code ANSI/NFPA NO. 70-LATEST EDITION, or in Canada, the installation must conform to applicable Canadian Standards: Canadian Electrical Codes Parts 1 & 2 CSA C22.1-1990 or LATEST EDITION. The ground connection may be to a proven earth ground at the location service panel.

For added personal safety, when possible, it is suggested that a separate ground wire (size per local codes) be connected from the ground connection of the dryer to a grounded cold water pipe. Do not ground to a gas pipe or hot water pipe. The grounded cold water pipe must have metal-to-metal connection all the way to the electrical ground. If there are any nonmetallic interruptions, such as, a meter, pump, plastic, rubber, or other insulating connectors, they must be jumped out with a wire (size per local codes) and securely clamped to bare metal at both ends.

**IMPORTANT:** For personal safety and proper operation, the dryer must be grounded.

Provisions are made for ground connection in each dryer at the electrical service connection area.

## Electrical Connections

A wiring diagram is located inside the control box for connection data.

If local codes permit, power to the dryer can be made by the use of a flexible UL listed power cord/pigtail (wire size must conform to rating of dryer), or the dryer can be hard wired directly to the service breaker panel. In both cases, a strain relief must be installed where the wiring enters the dryer.

## Gas Models Only

**IMPORTANT:** A separate protected circuit must be provided to each dryer.

## Single-Phase (1 $\phi$ ) Wiring Connections/Hookup

The electrical input connections on all single-phase (1 $\phi$ ) gas dryers are made into the rear service box located at the upper left area of the dryer.

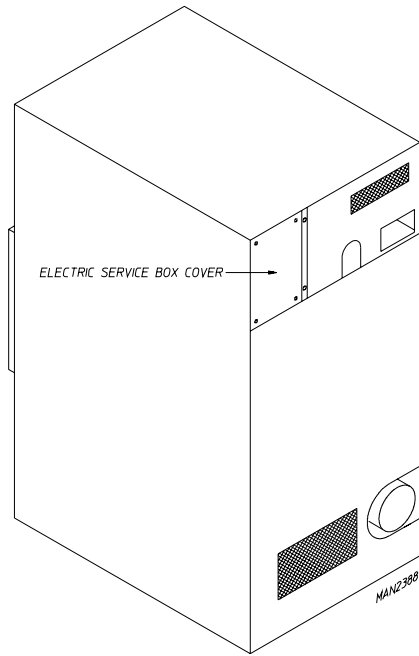
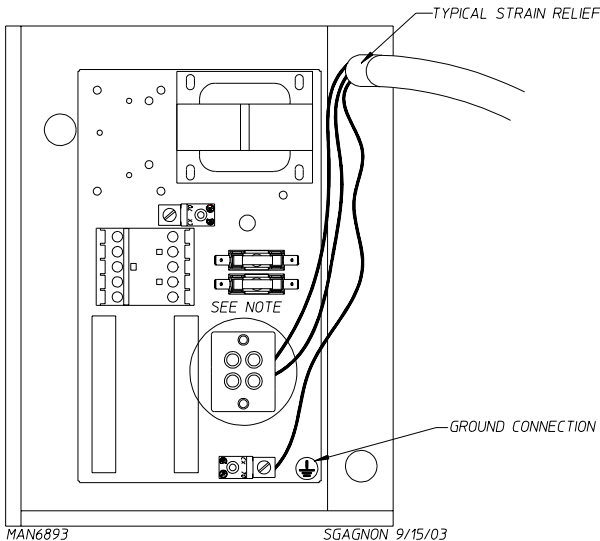

Single-Phase Electrical Lead Connections		
Black + Positive	White or Red + Neutral or L2	Green + Ground

## For 110V Applications

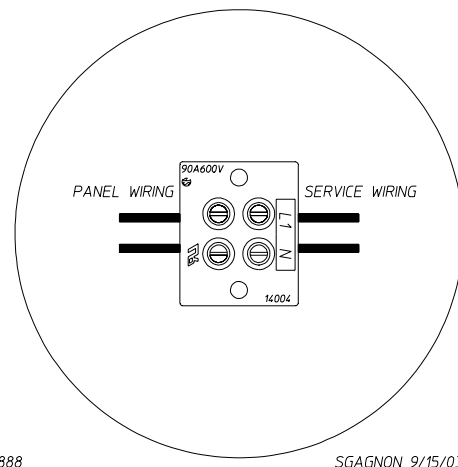
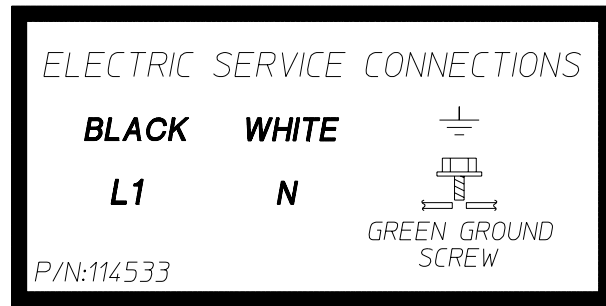

For 208-240V Applications

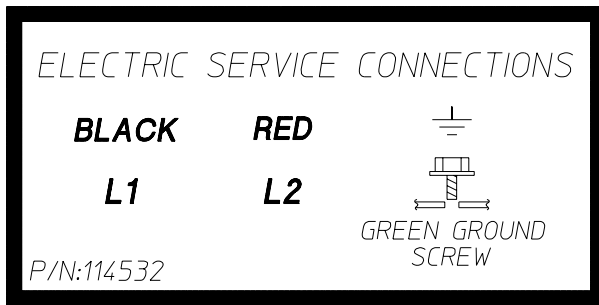

MAN6887

SGAGNON 9/15/03

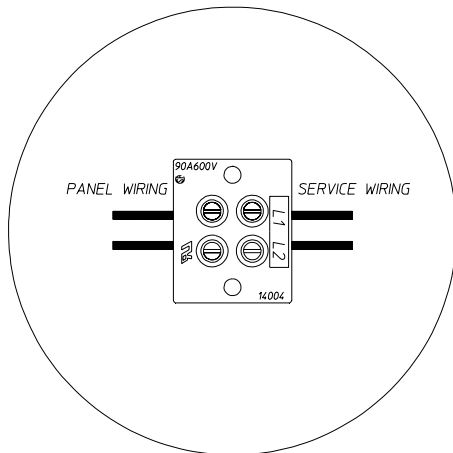

MAN6897

SGAGNON 9/15/03

A ground lug is provided in the rear electrical box to connect your service ground.

3-Phase (3 $\phi$ ) Wiring Connections/Hookup

The electrical connections on all 3-phase (3 $\phi$ ) gas dryers are made into the rear service box located at the upper left area of the dryer. The electrical connections are made at the power distribution block located in the service box. The ground connection is made to the copper lug, also provided in this box. To gain access, the service box cover must be removed.

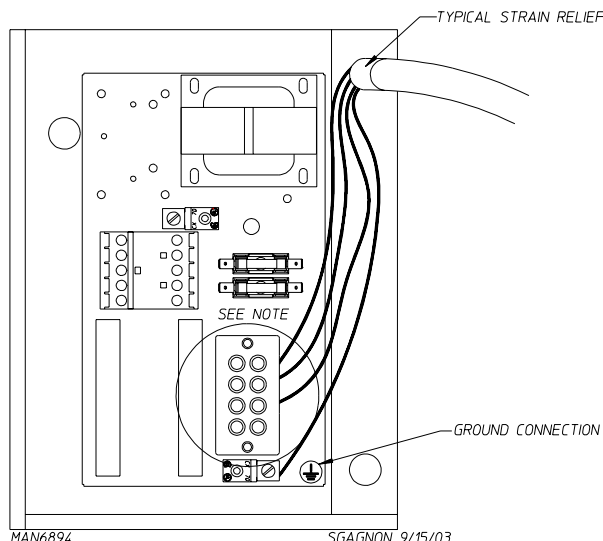

MAN6894

SGAGNON 9/15/03

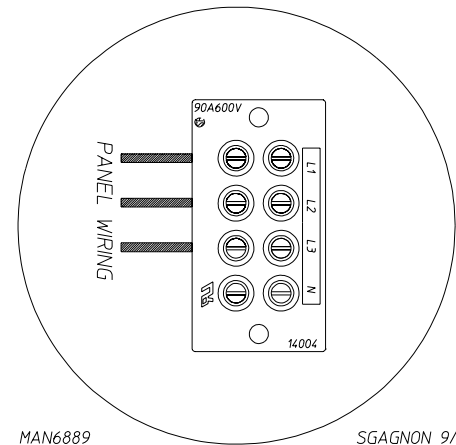

MAN6889

SGAGNON 9/15/03

The neutral will only be used on 4-wire service. This is typical for 380-416V, 50 Hz.

Electrically Heated Models Only

The only electrical input connections to the dryer are the 3-phase (3 $\phi$ ) power leads (L1, L2, L3, and sometimes neutral) and ground. Single-phase (1 $\phi$ ) power for the control circuit and for any single-phase (1 $\phi$ ) motors (if present) is done internally to the dryer by the factory at the oven contactor. No single-phase (1 $\phi$ ) input connection is required on a 3-phase (3 $\phi$ ) dryer.

**CAUTION: The dryer must be grounded. A ground lug has been provided for this purpose.**

Input connection wiring must be sized properly to handle the dryer's current draw. This information is printed on the dryer's data label.

The electrical input connections are made at the electric oven contactor located inside the assembly at the rear center upper section of the dryer. The ground connection is made to a copper lug also provided in this area. To gain access, remove oven rear service cover.

**IMPORTANT: A strain relief must be used where the input wiring enters the oven assembly.**

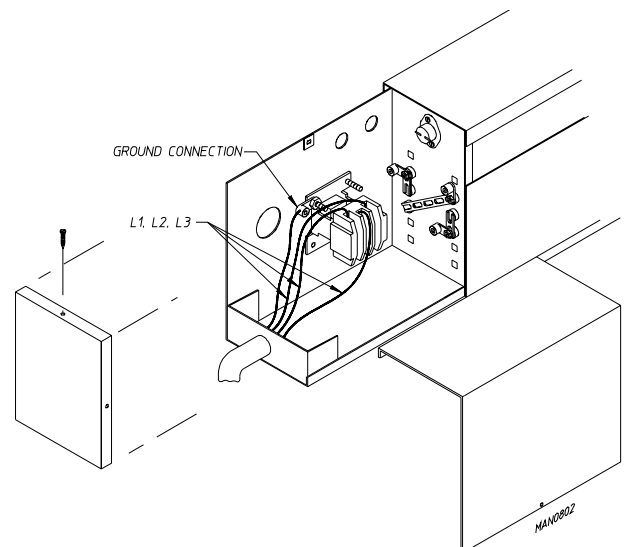

## Gas Information

It is your responsibility to have all plumbing connections made by a qualified professional to ensure that the gas plumbing installation is adequate and conforms to local and state regulations or codes. In the absence of such codes, all plumbing connections, materials, and workmanship must conform to the applicable requirements of the National Fuel Gas Code ANSI Z223.1-LATEST EDITION, or in Canada, the Canadian Installation Codes CAN/CGA-B149.1-M91 (Natural Gas) or CAN/CGA-B149.2-M91 (L.P. Gas) or LATEST EDITION.

In Australia, the fuel gas code is AS 5601/AG 601, local authority, gas, electricity, and any other relevant statutory regulations.

**IMPORTANT:** Failure to comply with these codes or ordinances, and/or the requirements stipulated in this manual, can result in personal injury and improper operation of the dryer.

Each dryer must have its own manual shutoff valve to provide isolation of the dryer from the gas supply.

The dryer and its individual shutoff valve must be disconnected from the gas supply piping system during any pressure testing of that system at test pressures in excess of 1/2 psig (3.5 kPa). The dryer must be isolated from the gas supply piping system by closing its individual manual shutoff valve during any pressure testing of the gas supply system at test pressures equal to or less than 1/2 psig (3.5 kPa).

**IMPORTANT:** Failure to isolate or disconnect the dryer from supply as noted can cause irreparable damage to the gas valve voiding the warranty.

### WARNING

**Fire or explosion could result due to failure of isolating or disconnecting gas supply as noted.**

## Gas Supply

The gas dryer installation must meet the American National Standard...National Fuel Gas Code ANSI Z223.1-LATEST EDITION, or in Canada, the Canadian Installation Codes CAN/CGA-B149.1 M91 (Natural Gas) or CAN/CGA-B149.2-M91 (L.P. Gas) or LATEST EDITION, as well as local codes and ordinances and must be done by a qualified professional.

**NOTE:** Undersized gas piping will result in ignition problems, slow drying, increased use of energy, and can create a safety hazard.

The dryer must be connected to the type of heat/gas indicated on the dryer data label. If this information does not agree with the type of gas available, do not operate the dryer. Contact the reseller who sold the dryer or contact the manufacturer.

**IMPORTANT:** Any burner changes or conversions must be made by a qualified professional.

The input ratings shown on the dryer data label are for elevations up to 2,000 feet (610 meters), unless elevation requirements of over 2,000 feet (610 meters) were specified at the time the dryer order was placed with the factory. The adjustment or conversion of dryers in the field for elevations over 2,000 feet (610 meters) is made by changing each burner orifice. If this conversion is necessary, contact the reseller who sold the dryer or contact the manufacturer.

**IMPORTANT:** This gas dryer is not provided with an internal gas supply shutoff and an external gas supply shutoff must be provided.

## Technical Gas Data

### Gas Specifications

Type of Gas	Manifold Pressure*	In-Line Pressure
Natural	3.5 in wc	6.0 - 12.0 in wc
	<b>8.7 mb</b>	<b>14.92 - 29.9 mb</b>
Liquid Propane	10.5 in wc	11.0 in wc
	<b>26.1 mb</b>	<b>27.4 mb</b>

Shaded areas are stated in metric equivalents

\* Measured at outlet side of gas valve pressure tap when gas valve is on.

### Gas Connections:

Inlet connection ..... 1/2" N.P.T.  
 Inlet supply size ..... 1/2" Pipe (minimum)  
 Btu/hr input ..... 60,000 (15,120 kcal/hr)

### Natural Gas

Regulation is controlled by the dryer's gas valve's internal regulator. Incoming supply pressure must be consistent between a minimum of 6.0 in WC (14.92 mb) and a maximum of 12.0 in WC (29.9 mb) pressure.

### L.P. Gas

Dryers made for use with L.P. gas have the gas valve's internal pressure regulator blocked open so that the gas pressure must be regulated upstream of the dryer. The pressure measured at each gas valve pressure tap must be a consistent 10.5 in WC (26.1 mb). There is no regulator or regulation provided in an L.P. dryer. The water column pressure must be regulated at the source (L.P. tank) or an external regulator must be added to each dryer.

		TYPE OF GAS					
Btu/hr Rating	kcal/hr Rating	Natural			Liquid Propane		
		Qty.	D.M.S.*	Part No.	Qty.	D.M.S.*	Part No.
60,000	<b>15,120</b>	2	#37	140815	2	#52	140800
Liquid Propane Conversion Kit Part Number 874058							

Shaded area is stated in metric equivalent

\* D.M.S. equivalents are as follows:

Natural Gas ..... #37 = 0.1040" (2.6416 mm).  
 L.P. Gas ..... #52 = 0.0635" (1.6129 mm).

## Piping Connections

All components/materials must conform to National Fuel Gas Code Specifications ANSI Z223.1-LATEST EDITION, or in Canada, CAN/CGA-B149.1-M91 (Natural Gas) or CAN/CGA-B149.2-M91 (L.P. Gas) or LATEST EDITION (for General Installation and Gas Plumbing), as well as local codes and ordinances and must be done by a qualified professional. It is important that gas pressure regulators meet applicable pressure requirements, and that gas meters be rated for the total amount of all the appliance Btu being supplied.

The dryer is provided with a 1/2" N.P.T. inlet pipe connection located at the right side of the base of the dryer. The minimum pipe size (supply line) to the dryer is 1/2" pipe. For ease in servicing, the gas supply line of each dryer must have its own shutoff valve.

**IMPORTANT:** The gas supply line to each dryer must be a minimum of 1/2-inch (12.7 mm). Do not reduce this pipe size requirement.

The size of the main gas supply line (header) will vary depending on the distance this line travels from the gas meter or, in the case of L.P. gas, the supply tank, other gas-operated appliances on the same line, etc. Specific information regarding supply line size should be determined by the gas supplier.

**NOTE:** Undersized gas supply piping can create a low or inconsistent pressure, which will result in erratic operation of the burner ignition system.

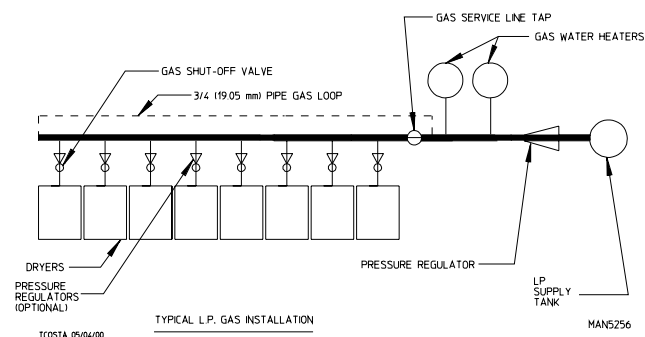
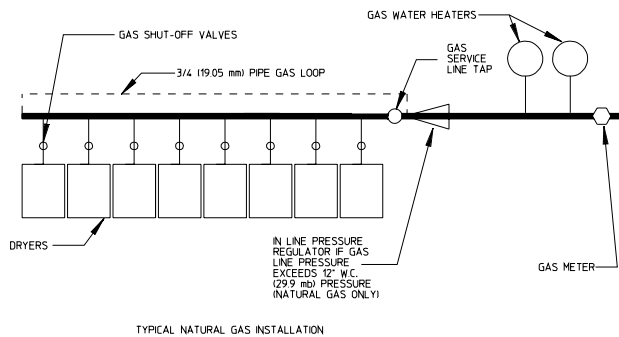

## Preparation for Operation / Start-Up

The following items should be checked before attempting to operate the dryer:

Read all "caution," "warning," and "direction" labels attached to the dryer.

Check incoming supply voltage to be sure that it is the same as indicated on the dryer data label.

Gas Models – check to ensure that the dryer is connected to the type of heat/gas indicated on the dryer data label.

The sail switch damper assembly was installed and adjusted at the factory prior to shipping. However, each sail switch adjustment must be checked to ensure that this important safety control is functioning.

Check bolts, nuts, screws, terminals, and fittings for tightness.

Gas Models – be sure that all gas shutoff valves are in the open position.

Be sure all back guard panels and service box covers have been replaced.

Check the lint door to ensure that it is closed and secured in place.

**IMPORTANT:** If during installation the lint door safety chain was disconnected, it must be reconnected or personal injury may result.

Rotate the tumbler by hand to be sure it moves freely.

## Preoperational Test

All dryers are thoroughly tested and inspected before leaving the factory. However, a preoperational test should be performed before the dryer is publicly used. It is possible that adjustments have changed in transit or due to marginal location (installation) conditions. Installer must instruct the user on how to correctly operate the dryer before leaving.

Turn on electric power to the dryer.

Refer to the operating instructions for starting your particular model dryer.

## Gas Dryers

When a gas dryer is first started (during initial start-up), it has a tendency not to ignite on the first ignition attempt. This is because the gas supply piping is filled with air, so it may take a few minutes for the air to be purged from the lines.

**NOTE:** During the purging period, check to be sure that all gas shutoff valves are open.

Gas model dryers are equipped with an ignition system, which has internal diagnostics. If ignition is not established after one time, the heat circuit in the ignition module will attempt two more ignitions (total of three ignition attempts). If there is no flame after the third ignition attempt, the module will lock out until it is manually reset. To reset the ignition system, open and close the main door and restart the dryer.

A gas pressure test should be taken at the gas valve pressure tap of each dryer to ensure that the water column pressure is correct and consistent.

**NOTE:** Water column pressure requirements (measured at the pressure tap of the gas valve body):

Natural Gas..... 3.5 in WC (8.7 mb).

L.P. Gas ..... 10.5 in WC (26.1 mb).

**IMPORTANT:** There is no regulator provided in an L.P. dryer. The water column pressure must be regulated at the source (L.P. tank) or an external regulator must be added to each dryer.

Make a complete operational check of all safety related circuits:

Door Switch(es)

Hi-Limit Thermostats

Cycling Thermostats

Sail Switch

**NOTE:** The sail switch can be checked for proper operation by opening the lint door while the heating circuit (gas burner/electric oven) is active (on). The heating unit should shut off within a few seconds. If not, make necessary adjustments to the sail switch.

Make a complete operational check of all operating controls.

**NOTE:** If computer program changes are required, refer to the computer programming section of the manual supplied with the dryer.

The dryer should be operated through one complete cycle to ensure that no further adjustments are necessary and that all components are functioning properly.

### Tumbler Coating

The tumbler is treated with a protective coating. We suggest dampening old garments or cloth material with a solution of water and nonflammable mild detergent and tumbling them in the tumbler to remove this coating.

Check the electric service phase sequence (3-phase [3Ø] models only). While the dryer is operating, check to see if the blower wheel (impellor/fan) is rotating in the proper direction. Looking from the front, the blower wheel (impellor/fan) should spin in the clockwise direction. If it is, the phasing is correct. If the phasing is incorrect, reverse the two leads at connections L1, L2, or L3 of the power supply to the dryer.

## Preoperational Instructions

### Coin Models

#### Microprocessor Controller (Computer)

When the microprocessor controller (computer) is in the ready state, the L.C.D. screen will display "Ready, Insert \$XX.XX (amount) to Start".

Insert coin(s). Once the correct "Amount to Start" has been inserted, the L.C.D. will display "Select Temperature".

Select temperature by pressing "HI," "MED," or "LO." The cycle will start and the L.C.D. will display the Dry Cycle selected and the remaining time.

The dryer will continue through the drying and cooling cycles, until the vended time has expired.

**NOTE:** To stop dryer, open main door or press the "PAUSE" key. Continuation of the cycle will resume only after the door has been closed and any of the three temperature selection is pressed.

Upon completion of the drying and cooling cycles, the tone (buzzer) will sound and the dryer will go into the Anti-Wrinkle Mode for 99 minutes, or until the main door has been opened.

**IMPORTANT:** For more detailed information regarding the microprocessor controller (computer) on your dryer, refer to the microprocessor user's manual included with the dryer.

### Mechanical Drop /

#### Rotary Coin Meter or Slide Coin Meter

Insert coin and turn knob (rotary type meter), or for slide meter unit, push in coin chute.

Select Temperature.

Push the "Start" button.

To stop dryer, open the main door.

### Non-Coin Models

The L.E.D. display reads "READY" (no cycle in progress).

Press the letter on the keypad corresponding to the cycle desired (i.e., key "D").

**NOTE:** "0-40" will require the "START/ENTER" key to be pressed after the number is selected in order to accept the selection and start drying.

The dryer will then start. (I.E., blower, tumbler, and heat.)

The L.E.D. display will read MANUAL DRYING CYCLE D, 00:00 MIN REMAIN.

**NOTE:** Press and hold the "UP ARROW" to view the tumbler temperature at any time.

The dryer can be stopped at any time by pressing the "STOP/CLEAR" key, at this time the dryer will go into a cycle pause. If the "STOP/CLEAR" key is pressed again at this point, the cycle that was in progress will be cancelled and returned to the "READY" state.

Press and hold the "DOWN ARROW" to view the tumbler RPM.

When the programmed drying time has expired, the Phase 7 non-coin microprocessor controller (computer) will proceed into the Cool Down Cycle.

Once the Cool Down Cycle begins at the end of the heat cycle, the L.E.D. display will read COOL DOWN TEMP \_\_\_/\_\_\_ MINUTES REMAINING. At the end of the heat cycle, the dryer will shut off the heat and continue the fan and tumbler until the Cool Down Time or temperature is reached.

**IMPORTANT:** For more detailed information regarding the microprocessor controller (computer) on your dryer, refer to the microprocessor user's manual included with the dryer.

### Dual Timer Dryers

Turn drying timer knob for a time of 20 minutes.

Select "High Temp."

Push "Push to Start" button.

To stop dryer, open the main door.

Spin and dwell (stop) times are adjustable at the reversing timer.



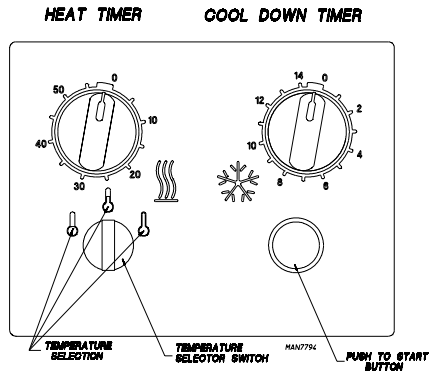

## Reversing Timer Spin / Dwell Adjustments

Timer models have an electronic reversing timer in the electrical service box, which is located in the upper left rear area of the dryer.

Both the Dwell (stop) Time and the tumbler Spin Time are adjustable by mode selection switches located on the electronic timer (as noted in the illustration below).

TIMING LEGEND					
<b>SPIN TIME</b>					
Adjustment Position Number	1	2	3	4	5
Time in Seconds*	30	60	90	120	150
<b>DWELL (STOP) TIME</b>					
Adjustment Position Number	1	2	3	4	5
Time in Seconds*	5	6.3	7.6	8.9	10.2
* Values shown are +/- 1-second.					

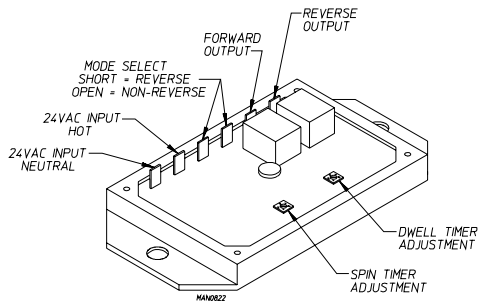

## Shutdown Instructions

If the dryer is to be shutdown (taken out of service) for a period of time, the following must be performed:

Discontinue power to the dryer either at the external disconnect switch or the circuit breaker.

Discontinue the gas supply (for gas models only):

Shut off external gas supply shutoff valve.

Shut off internal gas supply shutoff valve located in the gas valve burner area.

## Service / Parts Information

### Service

Service must be performed by a qualified trained technician, service agency, or gas supplier. If service is required, contact the reseller from whom the equipment was purchased. If the reseller cannot be contacted or is unknown, contact the Service Department for a reseller in your area.

**NOTE:** When contacting the Service Department, be sure to give them the correct model number and serial number so that your inquiry is handled in an expeditious manner.

### Parts

Replacement parts should be purchased from the reseller from whom the equipment was purchased. If the reseller cannot be contacted or is unknown, contact the Parts Department for a reseller in your area. Parts may also be purchased directly from the factory by calling the Parts Department at (508) 678-9000 or you may FAX in your order at (508) 678-9447.

**NOTE:** When ordering replacement parts from the reseller or the manufacturer, be sure to give them the correct model number and serial number so that your parts order can be processed in an expeditious manner.

## Warranty Information

### Returning Warranty Cards

Before any dryer leaves the factory test area, a warranty card is placed on the back side of the main door glass. These warranty cards are intended to serve the customer where we record the individual installation date and warranty information to better serve you should you file a warranty claim.

If a warranty card did not come with your dryer, contact the Warranty Department or the Service Department at (508) 678-9000.

**IMPORTANT:** A separate warranty card must be completed and returned for each individual dryer.

**NOTE:** Be sure to include the installation date when returning the warranty card(s).

### Warranty

For a copy of the commercial warranty covering your particular dryer(s), contact the reseller from whom you purchased the equipment and request a dryer warranty form. If the reseller cannot be contacted or is unknown, warranty information can be obtained from the factory by contacting the Warranty Department at (508) 678-9000.

**NOTE:** Whenever contacting the factory for warranty information, be sure to have the dryer's model number and serial number available so that your inquiry can be handled in an expeditious manner.

### Returning Warranty Parts

All dryer or parts warranty claims or inquiries should be addressed to the Warranty Parts Department. To expedite processing, the following procedures must be followed:

No parts are to be returned without prior written authorization (R.M.A.) from the factory.

**NOTE:** An R.M.A. is valid for only 30 days from date of issue.

The R.M.A. issued by the factory, as well as any other correspondence pertaining to the returned part(s), must be included inside the package with the failed merchandise.

Each part must be tagged with the following information:  
Model number and serial number of the dryer from which part was removed.  
Nature of failure (be specific).  
Date of dryer installation.  
Date of part failure.  
Specify whether the part(s) being returned is for a replacement, a credit, or a refund.

**NOTE:** If a part is marked for a credit or a refund, the invoice number covering the purchase of the replacement part must be provided.

Warranty tags (P/N 450064) are available at "no charge" from ADC upon request.

The company returning the part(s) must clearly note the complete company name and address on the outside of the package.

All returns must be properly packaged to ensure that they are not damaged in transit. Damage claims are the responsibility of the shipper.

**IMPORTANT:** No replacements, credits, or refunds will be issued for merchandise damaged in transit.

All returns should be shipped to the ADC factory in such a manner that they are insured and a proof of delivery can be obtained by the sender.

Shipping charges are not the responsibility of ADC. All returns should be "prepaid" to the factory. Any "C.O.D." or "COLLECT" returns will not be accepted.

**IMPORTANT:** No replacements, credits, or refunds will be issued if the claim cannot be processed due to insufficient information. The party filing the claim will be notified in writing, either by "FAX" or "CERTIFIED MAIL – Return Receipt Requested," as to the information necessary to process claim. If reply is not received by the Warranty Department within 30 days from the FAX/letter date, then no replacements, credits, or refunds will be issued, and the merchandise will be discarded.

## Routine Maintenance \_\_\_\_\_

### Cleaning

A program and/or schedule should be established for periodic inspection, cleaning, and removal of lint from various areas of the dryer, as well as throughout the ductwork system. The frequency of cleaning can best be determined from experience at each location. Maximum operating efficiency is dependent upon proper air circulation. The accumulation of lint can restrict this airflow. If the guidelines in this section are met, an ADC dryer will provide many years of efficient, trouble free, and most importantly, safe operation.

#### WARNING

**Lint from most fabrics is highly combustible. The accumulation of lint can create a potential fire hazard.**

**Keep dryer area clear and free from combustible materials, gasoline, and other flammable vapors and liquids.**

**NOTE:** Suggested time intervals shown are for average usage, which is considered six to eight operational (running) hours per day.

**IMPORTANT:** Dryer produces combustible lint and must be exhausted to the outdoors. Every six months, inspect the exhaust ducting and remove any lint buildup.

### Suggested Cleaning Schedule

#### Every Third or Fourth Load

Clean the lint screen every third or fourth load. A clogged lint screen will cause poor dryer performance. The lint screen is located behind the lint door in the base of the dryer. Open the lint door, brush the lint off the lint screen, and remove the lint. Inspect lint screen and replace if torn.

**NOTE:** The frequency of cleaning the lint screen can best be determined from experience at each location.

#### Weekly

Clean lint accumulation from lint chamber, thermostat, and microprocessor temperature sensor (sensor bracket) area.

#### WARNING

**To avoid the hazard of electrical shock, discontinue electrical supply to the dryer.**

#### 90 Days

Remove lint from around tumbler, drive motors, and surrounding areas.

Remove lint from gas valve burner area with a dusting brush or vacuum cleaner attachment.

Clean any lint accumulation in and around both the blower and drive motor casing openings.

**NOTE:** To prevent damage, avoid cleaning and/or touching ignitor/flame-probe assembly.

#### Every Six Months

Inspect and remove lint accumulation in customer furnished exhaust ductwork system and from dryer's internal exhaust ducting.

**NOTE:** The accumulation of lint in the exhaust ductwork can create a potential fire hazard.

Do not obstruct the flow of combustion and ventilation air. Check customer furnished back draft dampers in the exhaust ductwork. Inspect and remove any lint accumulation, which can cause the damper to bind or stick.

A back draft damper that is sticking partially closed can result in slow drying and shutdown of heat circuit safety switches or thermostats.

When cleaning the dryer cabinet(s), avoid using harsh abrasives. A product intended for the cleaning of appliances is recommended.

## Adjustments

### 7 Days After Installation and Every Six Months Thereafter

Inspect bolts, nuts, screws, setscrews, grounding connections, and nonpermanent gas connections (unions, shutoff valves, and orifices). Motor and drive belts should be examined. Cracked or seriously frayed belts should be replaced. Tighten loose V-belts when necessary. Complete operational check of controls and valves. Complete operational check of all safety devices (door switches, lint drawer switch, sail switch, burner and hi-limit thermostats).

## Lubrication

The motor bearings, idler bearings, and under normal/most conditions the tumbler bearings are permanently lubricated. It is physically possible to relubricate the tumbler bearings if you choose to do so even though this practice is not necessary. Use Shell Alvania #2 grease or its equivalent. The tumbler bearings used in the dryer do not have a grease fitting. Provisions are made in the bearing housing for the addition of a grease fitting, which can be obtained elsewhere, or from ADC by ordering kit P/N 882159 (includes two fittings).

## Data Label Information \_\_\_\_\_

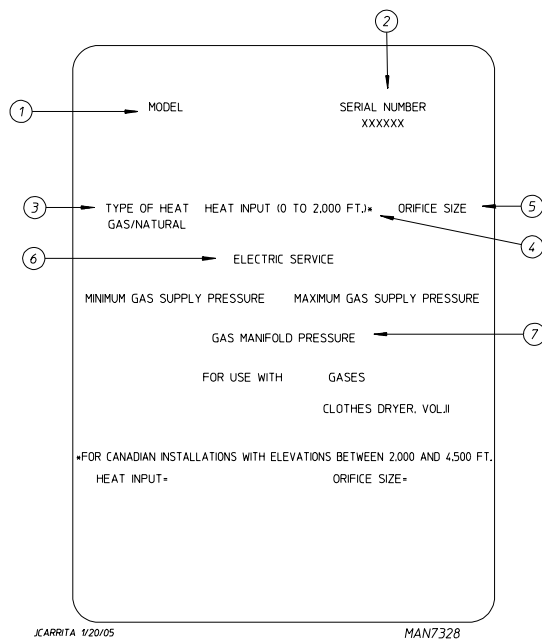

When contacting ADC, certain information is required to ensure proper service/parts information from ADC. This information is on the data label affixed to the left side panel area behind the top control (access) door. When contacting ADC, please have the model number and serial number available.

1. Model Number – This describes the style of dryer and type of heat (gas, electric, or steam).
2. Serial Number – Allows the manufacturer to gather information on your particular dryer.
3. Type of Heat – This describes the type of heat for your particular dryer, gas (either natural gas or L.P. gas), electric, or steam.

4. Heat Input (For Gas Dryers) – This describes the heat input in British thermal units per hour (Btu/hr) or kilowatts (kW).
5. Orifice Size (For Gas Dryers) – Gives the number drill size used.
6. Electric Service – This describes the voltage and current rating for a particular model.
7. Gas Manifold Pressure (For Gas Dryers) – This describes the manifold pressure taken at the gas valve tap.

## Procedure for Functional Check of Replacement Components \_\_\_\_\_

### Microprocessor Controller (Computer) Board Phase 7 Coin Models

Upon completing installation of the replacement microprocessor controller (computer) board, reestablish power to the dryer.

Start the drying cycle by pressing any temperature selection keys (HI, PP, or LO).

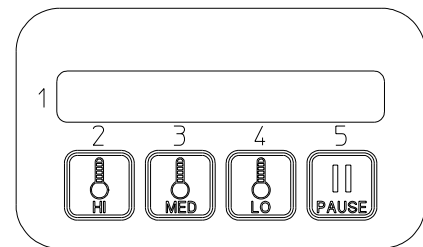

JM 9/17/03

MAN6873

Verify that the applicable indicator lights on the microprocessor controller (computer) board are lit. (Refer to the illustration below.)

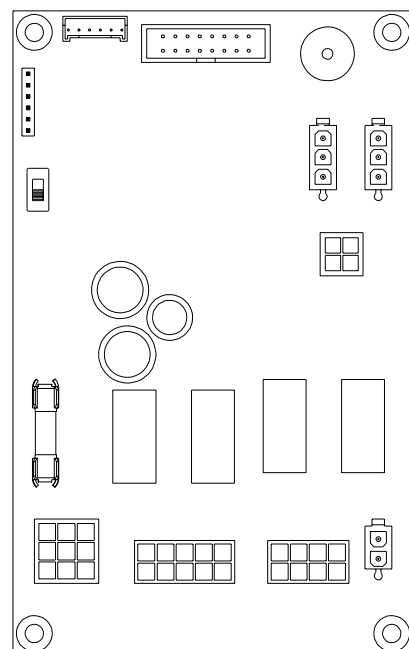

MAN6875

JM 9/11/03

## Phase 7 Non-Coin Models

Upon completing installation of the replacement microprocessor controller (computer) board, reestablish power to the dryer.

Start the drying cycle by pressing any of the preset cycles in letters A-F.

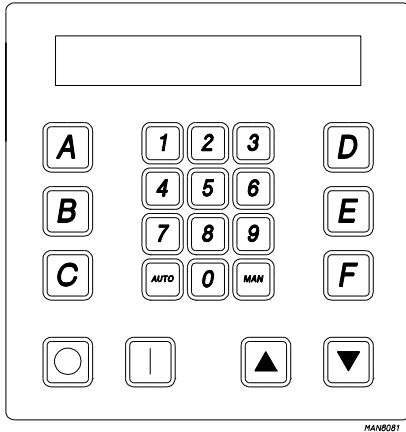

Verify that the applicable indicator lights on the microprocessor controller (computer) board are lit. (Refer to the illustration below.)

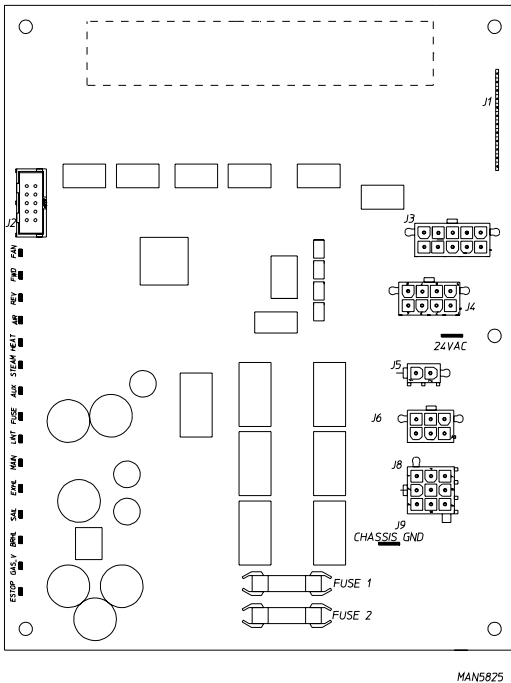

## For Models with DSI Module (Type I)

**Theory of Operation:** Start the drying cycle. When the gas burner ignites within the chosen trial for ignition time (6-seconds), the flame sensor detects gas burner flame and signals the DSI module to keep the gas valve open as long as there is a call for heat. The DSI module will “LOCKOUT” if the gas burner flame is not sensed at the end of the trial for ignition period. The trial for ignition period will be repeated for a total of three retries/trials (the initial try and two more retries/trials). If the flame is not sensed at the end of the third retry/trial (inter-purge period of 30-seconds), the DSI module will “LOCKOUT” (L.E.D. diagnostic indicator flashes).

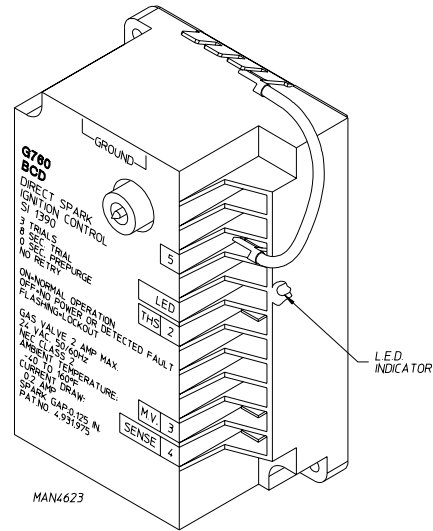

A steady L.E.D. indicator indicates normal operation.

No L.E.D. indicator indicates a power or an internal failure has occurred.

## For Models with DSI Module (Type II)

**Theory of Operation:** Start the drying cycle. When the gas burner ignites within the chosen trial for ignition time (8-seconds), the flame sensor detects gas burner flame and signals the DSI module to keep the gas valve open as long as there is a call for heat. The DSI module will “LOCKOUT” if the gas burner flame is not sensed at the end of the trial for ignition period. The trial for ignition period will be repeated for a total of three retries/trials (the initial try and two more retries/trials). If the flame is not sensed at the end of the third retry/trial (inter-purge period of 30-seconds), the DSI module will “LOCKOUT” (a red L.E.D. diagnostic indicator will flash).

An unlit red L.E.D. diagnostic indicator indicates normal operation.

A lit green L.E.D. diagnostic indicator indicates dryer controller is calling for heat and that all interlocks have been satisfied.

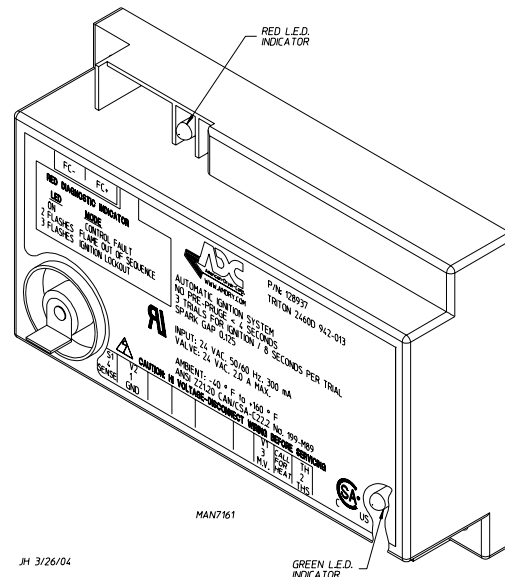

## S.A.F.E. System \_\_\_\_\_

The exclusive S.A.F.E. system will extinguish fires that may start in the drying tumbler. A series of sensors positioned throughout the tumbler and interfaced with the microprocessor will trigger the S.A.F.E. system water jet(s) to quickly extinguish the flames. The water jet(s) remain on for 2 minutes and will automatically activate again if a fire condition remains or reignites. While the water jet(s) are activated, the tumbler will jog to move the water throughout the load. The microprocessor will display that the system was activated and will continue to display until the dryer is attended to.

We have tried to make this manual as complete as possible and hope you will find it useful. ADC reserves the right to make changes from time to time, without notice or obligation, in prices, specifications, colors, and material, and to change or discontinue models.

### Before You Start!

#### Check Local Codes and Permits

Call your local water company or the proper municipal authority for information regarding local codes.

**IMPORTANT:** It is your responsibility to have all plumbing connections made by a qualified professional to ensure that the plumbing installation is adequate and conforms to local, state, and federal regulations or codes.

It is the installation or owners responsibility to see that the necessary or required water, water pressure, pipe size, or connections are provided. Manufacturer assumes no responsibility if the S.A.F.E. system is not connected, installed, or maintained properly.

### Installation

#### Requirements

The S.A.F.E. system must be supplied with a minimum water pipe size of 1/2" and be provided with 40 psi +/- 20 psi (2.75 bar +/- 1.37 bar) of pressure. For use of optional manual bypass, a second source with the same piping and pressure requirements is required.

Flexible 1/2 feeds must be provided to avoid damage to electric water solenoid valve by vibration.

**IMPORTANT:** Flexible supply line/coupling must be used. Solenoid valve failure due to hard plumbing connections will void warranty.

If the rear area of the dryer, or the water supply is located in an area where it will be exposed to cold/freezing temperatures, provisions must be made to protect these water lines from freezing.

### WARNING

**If the water in the supply line or water solenoid valve freezes, the S.A.F.E. system will be inoperative!!**

**IMPORTANT:** Appliance is to be connected to the water mains using a new hose set and the old hose set should not be reused.

### Water Connections

The water connection is made to the 3/4"-11.5 NH hose adapter of the electric water solenoid valve, located at the rear upper midsection of the dryer.

The water solenoid valve has a 3/8" M.P.T. connection supplied with a 3/4"-11.5 NH hose adapter to provide the minimum 1/2-inch supply (feed) line. Flexible supply line/coupling must be used in an effort to avoid damaging the electric water solenoid valve.

**NOTE:** The 3/4"-11.5 NH is a standard hose coupling screw thread. It is not to be confused with 3/4" N.P.T. The sealing of an NH connection is made with a washer opposed to the mating threads of an N.P.T. assembly. The two thread designs are not compatible.

**IMPORTANT:** Flexible supply line/coupling must be used. Solenoid valve failure due to hard plumbing connections will void warranty. It is recommended that a filter or strainer be installed in the water supply line.

### Typical water supply

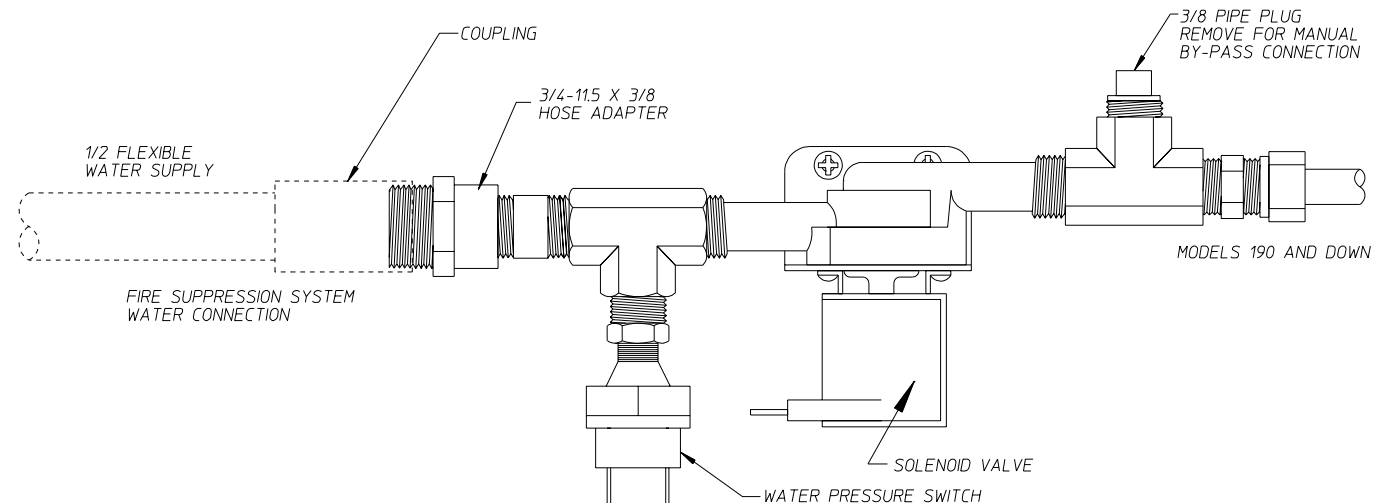

MG 12/3/03

MAN7032

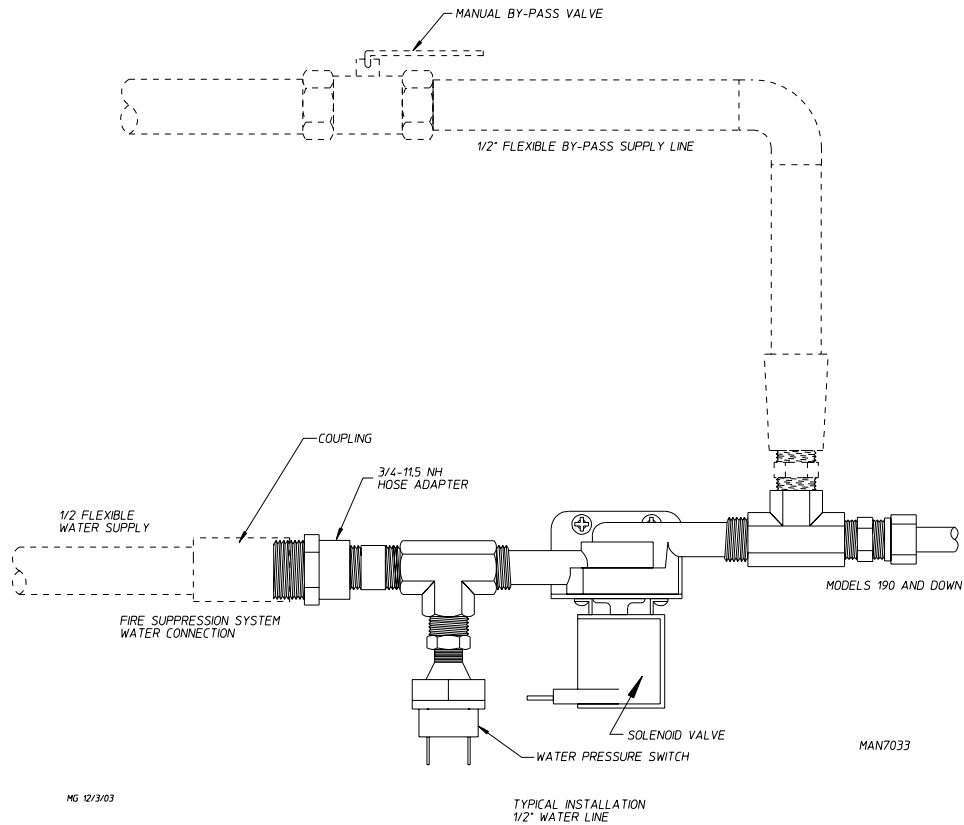

### Optional Manual Bypass

Provisions are made in the dryer S.A.F.E. system for the installation of an optional manual bypass. Depending on the model dryer, the connections for the manual bypass are made at the “T” or “three way” fitting located in the outlet supply side of the water solenoid valve. The use and connections of this manual bypass are at the option or discretion of the owner.

The water connection for the manual bypass is made to the “T” or “three way” fitting, which has a 3/8” F.P.T. and a coupling must be used to provide the minimum 1/2” supply (feed) line.

If the rear area of the dryer, or the water supply is located in an area where it will be exposed to cold/freezing temperatures, provisions must be made to protect these water lines from freezing.

### WARNING

**If the water in the supply line or water solenoid valve freezes, the S.A.F.E. system will be inoperative!!**

The manual ball cock shutoff valve must be located outside of the dryer at a distance from the dryer where it is easily accessible.

### Electrical Requirements

No independent external power source or supply connection is necessary. The 24 volt power to operate the S.A.F.E. system is accomplished internally in the dryer (from the dryer controls).

### WARNING

**Electrical power must be provided to the dryer at all times. If the main electrical power supply to the dryer is disconnected, the S.A.F.E. system is inoperative!!**

### S.A.F.E. System Theory of Operation

While the dryer is in an idle state, or 20-seconds after the heat turns off, the Phase 7 control monitors the thermistor probe, located in the top of the tumbler chamber, and records the minimum temperature. If the minimum recorded thermistor probe temperature is greater than 120° F (48° C) and the control detects a 50° rise in temperature, this will be the trip point and the S.A.F.E. system routine will activate.

While a drying cycle is in process and the heat has turned on at least once, the Phase 7 control monitors the exhaust temperature transducer. If the drying cycle temperature set point is set greater than 160° F (71° C) and the control detects an exhaust temperature rise 25° F greater than set point, this will be the trip point and the S.A.F.E. system routine will activate. If set point is below 160° F (71° C), the trip point will be 185° F (85° C).

Once the S.A.F.E. system routine is activated, the control will display “S.A.F.E. SYSTEMACTIVATED” and water will be injected into the tumbler chamber. Any time water is being injected into the tumbler, the tumbler drive will turn the load for 1-second every 15-seconds. This process will continue for a minimum of 2 minutes. After the 2 minutes have elapsed, the control will check if the temperature remained above trip point; if so, the water will remain on. The control will continue to check if the temperature is above trip point every 30-seconds. If the water has been on for a constant 10 minutes, the water will be turned off, regardless of the temperature, and the control will display “S.A.F.E. SYSTEM WAS ACTIVATED.” If the temperature has dropped below trip point, the control will turn off the water prior to 10 minutes.

## System Reset

After the microprocessor determines that the situation is under control and shuts the water being injected into the tumbler off, the microprocessor display will read "S.A.F.E. SYSTEM WAS ACTIVATED," and the horn/tone will sound until reset manually.

**NON-COIN** – To reset the microprocessor once the control displays "S.A.F.E. SYSTEM WAS ACTIVATED," press the red "STOP/CLEAR" key on the keypad.

**COIN** – To reset the microprocessor once the control displays "S.A.F.E. SYSTEM WAS ACTIVATED," press and hold the red "PAUSE" key for 3-seconds on the keypad.

## S.A.F.E. System Water Valve Check

The operation of the water solenoid valve can be tested to ensure that the water supply system and valve are functional. Before attempting a system check, be sure that all water supply shutoff valves to the dryer are in the OPEN position; the dryer must be in the "READY" mode with no cycle loaded or in progress.

### Non-Coin

Press and hold the red "STOP/CLEAR" key (while in "READY" mode and no cycle is in progress).

Press and hold the "A" key.

Water valve will open and water will be dispensed into tumbler area as long as both keys are held.

The Phase 7 non-coin microprocessor controller (computer) will prompt the user to perform a S.A.F.E. system valve check at every 4000 hours to ensure proper functionality. At the 4000 hour mark, the control will wait for end of the cycle and then will prompt the user to "PLEASE EMPTY TUMBLER, THEN PRESS THE 'STOP/CLEAR' AND 'A' KEYS TO TEST THE WATER VALVE." When the 'STOP/CLEAR' and 'A' keys are pressed, the control will activate the S.A.F.E. system water valve for 2-seconds, at which point the control will prompt the user with the following message: "IF WATER DID NOT TURN ON, CALL FOR SERVICE. THANK YOU."

**NOTE:** *The control will not let the user continue until the valve test has been completed.*

### Coin

While the control is in the program mode, press and hold the "PAUSE" key for 3-seconds to get into the valve test mode. Valve test mode: The control will display "PRESS AND HOLD MEDIUM TO OPEN WATER VALVE". When the medium key is pressed, the control will activate the water output.

## S.A.F.E. System Diagnostics

**NON-COIN** – In the event that the Phase 7 non-coin microprocessor controller (computer) detects a fault in the S.A.F.E. system, the control will display the message "S.A.F.E. SYSTEM DISABLED...READY." To find out why the S.A.F.E. system is disabling, press and hold the red "STOP/CLEAR" and green "START" keys. This will cause the control to display a diagnostic message, as detailed in the "S.A.F.E. SYSTEM Diagnostics Messages" section.

**COIN** – In the event that the Phase 7 microprocessor controller (computer) detects a fault in the S.A.F.E. system, the control will display the message "S.A.F.E. SYSTEM DISABLED...READY, INSERT XX TO START." To find out the reason for the S.A.F.E. system disabling, press and hold the red "PAUSE" and "LOW" keys. This will cause the control to display a diagnostic message, as detailed in the following section.

## S.A.F.E. System Diagnostics Messages

**OPEN THERMISTOR PROBE** – This message indicates that the S.A.F.E. system thermistor probe either is not connected or is damaged. If this condition is detected, the Phase 7 non-coin control will immediately enter S.A.F.E. SYSTEM DISABLED mode.

**SHORTED THERMISTOR PROBE** – This message indicates that the S.A.F.E. system thermistor probe is damaged or the wiring is shorted. If this condition is detected, the Phase 7 non-coin control will immediately enter S.A.F.E. SYSTEM DISABLED mode.

**DISCONNECTED WATER VALVE** – This message indicates that the water valve is open or that it is not connected to the control. If this condition is detected, the Phase 7 non-coin control will continue to monitor the condition for a period of 5 minutes before entering S.A.F.E. SYSTEM DISABLED mode. Once the condition is corrected, the control will continue to monitor the condition for 1 minute before exiting S.A.F.E. SYSTEM DISABLED mode.

**SHORTED WATER VALVE** – This message indicates that the water valve is shorted or that the wiring to the valve is shorted. If this condition is detected, the Phase 7 non-coin control will continue to monitor the condition for a period of 5 minutes before entering S.A.F.E. SYSTEM DISABLED mode. Once the condition is corrected, the control will continue to monitor the condition for 1 minute before exiting S.A.F.E. SYSTEM DISABLED mode.

**WATER NOT CONNECTED** – This indicates that there is no water pressure at the water valve. This will occur if water is not connected to the dryer, or if there is low water pressure in the water line coming to the dryer. This could also signify a defective pressure switch or defective wiring to the pressure switch. If this condition is detected, the Phase 7 non-coin control will continue to monitor the condition for a period of 5 minutes before entering S.A.F.E. SYSTEM DISABLED mode. Once the condition is corrected, the control will continue to monitor the condition for 1 minute before exiting S.A.F.E. SYSTEM DISABLED mode.

## Starting a Cycle

### When Computer Is In

#### "S.A.F.E. System Is Disabled" Mode

**NON-COIN** – When the S.A.F.E. system is disabled, the user can still start a cycle. However, when a cycle is started, the control will display the following message: "S.A.F.E. SYSTEM IS DISABLED. PRESS 'START' TO CONTINUE." This message will be displayed every time a cycle is started, until the disabling condition has been corrected.

**COIN** – When the S.A.F.E. system is disabled, the user can still start a cycle. Simply insert credit and select a cycle to start.

# Non-Coin Programming

To Enter Programming Mode  
Press **0** And **▲** Keys Together

To Exit Programming Mode Press **0** Multiple Times  
Until Display Returns to "Ready".

0:	SELECT LANGUAGE
1:	SELECT SYSTEM PARAMETERS
0:	DRYER SETUP
0:	SELECT MODEL
1:	SYSTEM TEMP
2:	ENTER LINT COUNT 1 TO 5
3:	ENTER AUDIO ALERT ON TIMES 0 TO 10
4:	ROTATION SENSOR
1:	REVERSING SETUP
0:	ENTER SPIN TIME 30 TO 120 SECONDS
1:	ENTER STOP TIME 5 TO 10 SECONDS
	WRINKLE GUARD SETUP
2:	WRINKLE GUARD AUDIO ALERT
3:	STEAM INJECTION SETUP
2:	PROGRAM A - F CYCLES
	ENTER A - F
	SELECT CYCLE TYPE
	AUTO
0:	REVERSE MODE
1:	ENTER DRY TEMP 160 (71) TO 200 F (94 C) *
2:	ENTER DRYNESS LEVEL
3:	ENTER CYCLE ADJUSTMENT VALUE 0 TO 99
4:	CONTROLLED COOL DOWN
5:	ENTER COOL DOWN TIME 0 TO 99 MINUTES
6:	ENTER COOL DOWN TEMP 70 (21) TO 100 F (38 C)
	MANUAL
0:	REVERSE MODE
1:	ENTER DRY TIME 0 TO 99 MINUTES
2:	ENTER DRY TEMP 100 (38) TO 200 F (94 C) *
3:	CONTROLLED COOL DOWN
4:	ENTER COOL DOWN TIME 0 TO 99 MINUTES
5:	ENTER COOL DOWN TEMP 70 (21) TO 100 F (38 C)
6:	STEAM INJECTION
3:	PROGRAM 0 - 40 CYCLES
	ENTER 0 - 40
	SELECT CYCLE TYPE
	AUTO
0:	REVERSE MODE
1:	ENTER DRY TEMP 160 (71) TO 200 F (94 C) *
2:	ENTER DRYNESS LEVEL
3:	ENTER CYCLE ADJUSTMENT VALUE 0 TO 99
4:	CONTROLLED COOL DOWN
5:	ENTER COOL DOWN TIME 0 TO 99 MINUTES
6:	ENTER COOL DOWN TEMP 70 (21) TO 100 F (38 C)
	MANUAL
0:	REVERSE MODE
1:	ENTER DRY TIME 0 TO 99 MINUTES
2:	ENTER DRY TEMP 100 (38) TO 200 F (94 C) *
3:	CONTROLLED COOL DOWN
4:	ENTER COOL DOWN TIME 0 TO 99 MINUTES
5:	ENTER COOL DOWN TEMP 70 (21) TO 100 F (38 C)
6:	STEAM INJECTION
4:	DEFAULT SETTING FAULT HISTORY
5:	SAFE SYSTEM VALVE TEST OR <b>0</b> + <b>▲</b>
DISPLAY: <b>0</b> SAFE TEMP <b>▲</b> TUMBLER TEMP <b>▼</b> CTL VAC / RPM	
* 160 F (71 C) MAXIMUM TEMP ON AXIAL MODELS	

## Phase 7.2 Non-Coin Diagnostic Codes

- MAIN DOOR OPENED – A main door or door circuit is open.
- EXHAUST HIGH TEMP FAULT – Tumbler is above 220° F (104° C).
- LINT ACCESS OPEN – Lint drawer or lint door circuit is open.
- EXHAUST HIGH LIMIT FAULT – Temp. disk under tumbler is open.
- SAIL SWITCH CLOSED FAULT – Sail switch is closed – should be open at the start of a cycle.

SAIL SWITCH OPEN FAULT – Sail switch remained open after the cycle started. Should have closed.

BURNER HIGH LIMIT FAULT – Burner temp. disk has opened.

BURNER IGNITION CONTROL – No signal to gas valve from (DSI) module during trial for ignition time. DSI module is bad.

IGNITION FAULT – Gas valve did not remain open after trial for ignition. Indicates that no flame was detected.

FLAME FAULT – Flame was detected during trial for ignition but failed later.

ROTATION FAULT – Indicates the tumbler is not rotating.

OPEN EXHAUST TEMPERATURE PROBE – Indicates the exhaust temperature probe is open or shorted.

OPEN FIRE SUPPRESSION SYSTEM (F.S.S.) PROBE FAULT – Indicates the temperature probe for the F.S.S. is open or shorted.

LOW VOLTAGE FAULT – Volt dropped below the operating value.

EE PROM FAULT ### – Error in memory location. Fault correction:

Enter the program mode by pressing the UP and STOP keys.

Press "4" and ENTER keys in password "FAA" Press UP ARROW.

Press enter to confirm reset of EE PROM.

## Inputs (Red L.E.D.s)

All indications are with L.E.D. lit

ESTOP – Indicates E-STOP has been pressed.

GAS\_V – Indicates the gas valve is open (ON).

BRHL – Indicates the burner high limit disk is closed (temperature below 330° F [166° C]).

SAIL – Indicates the sail switch is closed.

EXHL – Indicates the exhaust high limit disk is closed (temperature below 225° F [107° C]).

MAIN – Indicates the status of main door is closed.

LINT – Indicates the lint drawer is closed.

FUSE – Indicates the status of the control voltage after POWER ON button has been pressed.

## Outputs (Green L.E.D.s)

All indications are with L.E.D. lit

AUX – This is for a spare output to be programmed.

STEAM – Indicates the status of the steam injection output.

\_HEAT – Indicates the status of the heat output.

AIR – Indicates the status of the air jet output.

REV – Indicates the status of the tumbler reverse direction output.

If the request to tumble the drum in the reverse direction is made, then the L.E.D. is ON.

FWD – This L.E.D. will indicate the status of the tumbler forward direction output.

FAN – This L.E.D. will indicate the status of the fan output.



## Coin Programming

Enter Programming Mode By Placing  
The Programming Switch On The Phase 7 Board Up  
While No Cycle Is In Progress.  
"Program Mode" Will Then Be Displayed.

Navigating Within The Programming Mode:

"Med" Key To Enter A Program Location.  
"Hi-temp" / "Lo-temp" Keys Increase / Decrease  
Program Location.  
"Pause" Key Rejects Entry And Moves To Next  
Program Location.

Changing A Parameter Value:

With Parameter Value Displayed Pressing "Lo Temp"  
Or "High Temp" Changes The Parameter Value.  
"Med" Key Must Be Pressed To Accept A New Parameter.

	FUNCTION	SAMPLE AXIAL DRYER SETTINGS
PL01  CONTROL SETTINGS	Language	English
	Temperature Scale	F
	Buzzer Mode	Buzz
	Beep Count 1 to 9 Beeps	2
	Dry Mode	Coin Dry Mode
	Pause Time 1 to 3 Minutes	1 Minute
	Ready Prompt	Rdy Inst Amt to Start
PL02  MACHINE SETTINGS	Model	Gas Dual Motors
	Rotation Sensor	On
	Lint Clean 1 to 10 Hours	2
	Axial Thermistor Input	On
	Axial Thermistor Setpoint	180F 82C
PL03  HI KEY SETTINGS	Time for Amt to Start 1-99M	10 Minutes
	Time for Top Off 1 to 99 M	10 Minutes
	Dry Temp 100 to 190F*	150F 66C
	Cool Time 0 to 9 Minutes	2
PL04  MED KEY SETTINGS	Time for Amt to Start 1-99M	12 Minutes
	Time for Top Off 1 to 99 M	12 Minutes
	Dry Temp 100 to 190F*	140F 60C
	Cool Time 0 to 9 Minutes	2
PL05  LO KEY SETTINGS	Time for Amt to Start 1-99M	14 Minutes
	Time for Top Off 1 to 99 M	14 Minutes
	Dry Temp 100 to 190F*	120F 49C
	Cool Time 0 to 9 Minutes	2
PL06  VENDING ITEMS	Currency Symbol	USD (\$)
	Vending Mode	Accumulative Time
	Vending Safeguard	Bad Coin Reset
	Left Coin Den .05 to 25.00	0.25
	Right Coin Den .05 to 25.00	0.10
	Amount to Start .05 to 25.00	0.25
	Amount for Top Off	0.25
PL07	No Faults / Faults	

150F (66C) Maximum Temperature on Axial Models

Typical Programming Example:

Change a single coin acceptor from factory setting to yield  
20 minutes for \$.50, \$.50 as the minimum amount to start,  
and no differential in regard to temperature key selection.

Settings: Time for Amt to Start (PL03, PL04, PL05) 20  
Left Coin Denomination (PL06) ..... \$.25  
Amount to Start (PL06) ..... \$.50

Clearing Coin Credit:

NO CYCLE IN PROGRESS AND PROGRAM SWITCH DOWN.

Hold PAUSE while pressing HI 3 times, LO twice, and MED  
once.

"Clear Credit?" will appear. Press any key to complete.

Accessing and Clearing Coin Vault Total

Enter program mode by switching program switch (up) while  
no cycle is in progress.

Press HI – "Coin Vault total is \$XXX" will appear.

Press HI – "Clear Coin Vault Total?" will appear.

Press MED to clear this amount or PAUSE to leave as is.

Hot Keys:

In the Coin Mode Hot Keys are enabled while in a cycle by  
placing the program switch in the program (up) position.

In Free Mode Hot Keys are always enabled.

HI – Remaining credit – coin mode / remaining time – free  
mode.

MED – Temps – Exhaust / left, S.A.F.E. / right, Axial / middle  
(Axial dryer)

LO – Tumbler RPM

S.A.F.E. TEST: Switch to program mode. Press and hold the  
"Pause" key until prompted to press MED to open the water.

L.C.D. Operating Messages

When Display Reads "Out of Order"

Pressing LO displays one of the causes listed below.

MODEL FAULT – Wrong model selected at PL01/3rd position.

SAIL SWITCH CLOSED – Sail switch closed before starting.

SAIL SWITCH OPEN – Sail switch failed to close after starting.

BURNER HI-LIMIT – Oven thermostat switch has opened.

EXHAUST HI-LIMIT – Tumbler thermostat switch has  
opened.

BURNER CONTROL – No gas valve signal – Bad DSI unit.

IGNITION FAULT – No flame ignition detected thru all retries.

FLAME FAULT – Flame detected at ignition but failed later.

CLEAN LINT – Due to failure to clean out lint.

CHECK CONTROL BOARD FUSE #2 – 2 on Phase 7 board  
is open.

EXHAUST PROBE FAULT / AXIAL – Indicated probe has  
failed.

ROTATION SENSOR – Rotation sensor or tumbler drive has  
failed.

EXHAUST HI-TEMP – Overheating condition has occurred.

BURNER PURGE FAULT – Gas return signal before heat  
output.

"S.A.F.E. System Disabled"

In Coin Mode hold "Pause" and "LO" keys down together.

OPEN / SHORTED THERMISTOR – Probe or probe circuit  
bad.

OPEN / SHORTED WATER VALVE – Water valve or circuit  
bad.

WATER NOT CONNECTED – No water pressure at sol. valve.

"S.A.F.E. System (was) Activated"

Indicates the S.A.F.E. system is active or was active because  
a fire was detected. The buzzer sounds at a fast pace while  
the system is active.

