

AD-35x2 and AD-35x2R Installation Manual

WARNING: For your safety the information in this manual must be followed to minimize the risk of fire or explosion and to prevent property damage, personal injury or death.

— Do not store or use gasoline or other flammable vapors and liquids in the vicinity of this or any other appliance.

— WHAT TO DO IF YOU SMELL GAS:

- Do not try to light any appliance.
- Do not touch any electrical switch; do not use any phone in your building.
- Clear the room, building or area of all occupants.
- Immediately call your gas supplier from a neighbor's phone. Follow the gas supplier's instructions.
- If you cannot reach your gas supplier, call the fire department.

— Installation and service must be performed by a qualified installer, service agency or the gas supplier.

AVERTISSEMENT: Assurez-vous de bien suivre les instructions données dans cette notice pour réduire au minimum le risque d'incendie ou d'explosion ou pour éviter tout dommage matériel, toute blessure ou la mort.

— Ne pas entreposer ni utiliser d'essence ni d'autres vapeurs ou liquides inflammables à proximité de cet appareil ou de tout autre appareil.

— QUE FAIRE SI VOUS SENTEZ UNE ODEUR DE GAZ:

- Ne pas tenter d'allumer d'appareils.
- Ne touchez à aucun interrupteur. Ne pas vous servir des téléphones se trouvant dans le bâtiment.
- Évacuez la pièce, le bâtiment ou la zone.
- Appelez immédiatement votre fournisseur de gaz depuis un voisin. Suivez les instructions du fournisseur.
- Si vous ne pouvez rejoindre le fournisseur de gaz, appelez le service des incendies.

— L'installation et l'entretien doivent être assurés par un installateur ou un service d'entretien qualifié ou par le fournisseur de gaz.



American Dryer Corporation
88 Currant Road
Fall River MA 02720-4781 USA
Telephone: +1 (508) 678-9000 / Fax: +1 (508) 678-9447
e-mail: techsupport@amdry.com

www.amdry.com

ADC Part No. 113297-1

Retain This Manual in a Safe Place for Future Reference

This product embodies advanced concepts in engineering, design, and safety. If this product is properly maintained, it will provide many years of safe, efficient, and trouble free operation.

Only qualified technicians should service this equipment.

OBSERVE ALL SAFETY PRECAUTIONS displayed on the equipment or specified in the installation manual included with the dryer.

The following **“FOR YOUR SAFETY”** caution must be posted near the dryer in a prominent location.

FOR YOUR SAFETY

Do not store or use gasoline or other flammable vapors and liquids in the vicinity of this or any other appliance.

POUR VOTRE SÉCURITÉ

Ne pas entreposer ni utiliser d'essence ni d'autres vapeurs ou liquides inflammables à proximité de cet appareil ou de tout autre appareil.

We have tried to make this manual as complete as possible and hope you will find it useful. The manufacturer reserves the right to make changes from time to time, without notice or obligation, in prices, specifications, colors, and material, and to change or discontinue models. The illustrations included in this manual may not depict your particular dryer exactly.

IMPORTANT

For your convenience, log the following information:

DATE OF PURCHASE _____ MODEL NO. _____

RESELLER'S NAME _____

SERIAL NUMBER(S) _____

Replacement parts can be obtained from your reseller or the ADC factory. When ordering replacement parts from the factory, you can FAX your order to ADC at +1 (508) 678-9447 or telephone your order directly to the ADC Parts Department at +1 (508) 678-9000. Please specify the dryer model number and serial number in addition to the description and part number, so that your order is processed accurately and promptly.

These instructions are only valid if the following country code is on the appliance... If this code is not present on the appliance, it is necessary to refer to the technical instructions which will provide the necessary information concerning the modification of the appliance to the condition of use for the country.

In accordance with EN ISO 3166-1, the names of countries shall be represented by the following codes:

GB United Kingdom
IE Ireland

“IMPORTANT NOTE TO PURCHASER”

Information must be obtained from your local gas supplier on the instructions to be followed if the user smells gas. These instructions must be posted in a prominent location near the dryer.

WARNING

Proposition 65

Use of this product could expose you to substances from fuel combustion that contain chemicals known to the State of California to cause cancer, birth defects and other reproductive harm.

IMPORTANT

You must disconnect and lockout the electric supply and the gas supply or the steam supply before any covers or guards are removed from the machine to allow access for cleaning, adjusting, installation, or testing of any equipment per OSHA standards.

Please observe all safety precautions displayed on the equipment and/or specified in the installation manual included with the dryer.

CAUTION

Dryer(s) should never be left unattended while in operation.

“Caution: Label all wires prior to disconnection when servicing controls. Wiring errors can cause improper operation.”

«Attention: Au moment de l'entretien des commandes, étiquetez tous les fils avant de les débrancher. Des erreurs de câblage peuvent entraîner un fonctionnement inadéquat et dangereux.»

WARNING

Children should not be allowed to play on or near the dryer(s). Children should be supervised if near dryer(s) in operation.

Under no circumstances should the dryer door switch, lint door switch, or heat safety circuit ever be disabled.

Do not modify this appliance.

The dryer must never be operated with any of the back guards, outer tops, or service panels removed. Personal injury or fire could result.

The dryer must never be operated without the lint filter/screen in place, even if an external lint collection system is used.

If the hi-limit switch trips, a service call is required to investigate the reason and resolve the issue.

FOR YOUR SAFETY

Do not dry mop heads in the dryer. Do not use dryer in the presence of dry cleaning fumes.

The dryers must not be installed or stored in an area where it will be exposed to water and/or weather.

The wiring diagram for the dryer is located in the front electrical control box area.

In the State of Massachusetts, the following installation instructions apply:

- Installations and repairs must be performed by a qualified or licensed contractor, plumber, or gasfitter qualified or licensed by the State of Massachusetts.
- If using a ball valve, it shall be a T-handle type.
- A flexible gas connector, when used, must not exceed 3 feet.

Table of Contents

Safety Precautions	4
Specifications	5
Installation Procedures	6
Unpacking / Setting Up	6
Location of the Dryer	6
Dryer Enclosure Requirements	6
Fresh Air Supply Requirements	7
Exhaust Requirements	7
Electrical Information	9
Gas Information	10
Preparation for Operation / Start-Up	11
Preoperational Test	12
Preoperational Instructions	12
Shutdown Instructions	12
Service / Parts Information	12
Service	12
Parts	13
Warranty Information	13
Warranty Registration	13
Warranty	13
Returning Warranty Parts	13
Routine Maintenance	13
Cleaning	13
Adjustments	14
Data Label Information	14
Procedure for Functional Check of Replacement Components	15

List of Acronyms

D.M.S.	Drill Measurement Size
HVAC	Heating, Ventilating, and Air-Conditioning
in WC	Inches of Water Column
L.C.D.	Liquid Crystal Display
L.E.D.	Light Emitting Diode
L.P.	Liquid Propane
OSHA	Occupational Safety and Health Administration
R.M.A.	Return Material Authorization
UL	Underwriters Laboratory

Safety Precautions

WARNING

For your safety, the information in this manual must be followed to minimize the risk of fire or explosion or to prevent property damage, personal injury, or loss of life.

The dryer must never be operated with any of the back guards, outer tops, or service panels removed. Personal injury or fire could result.

Keep dryer area clear and free from combustible materials, gasoline, and other flammable vapors and liquids.

Do not spray aerosols in the vicinity of this appliance while it is in operation.

Purchaser/user should consult the local gas supplier for proper instructions to be followed in the event the user smells gas. The instructions should be posted in a prominent location.

What To Do If You Smell Gas:

- Do not try to light any appliance.
- Do not touch any electrical switch.
- Do not use any phone in your building.
- Clear the room, building, or area of all occupants.
- Immediately call your gas supplier from a neighbor's phone. Follow the gas supplier's instructions.
- If you cannot reach your gas supplier, call the fire department.

Installation and service must be performed by a qualified installer, service agency, or gas supplier.

Dryers must be exhausted to the outdoors.

Although the manufacturer produces a very versatile dryer, there are some articles that, due to fabric composition or cleaning method, should not be dried in it.

WARNING

Dry only water washed fabrics. Do not dry articles spotted or washed in dry cleaning solvents, combustible detergents, or "all purpose" cleaner. Explosion could result.

Do not dry rags or articles coated or contaminated with gasoline, kerosene, oil, paint, or wax. Explosion could result.

Do not dry mop heads. Contamination by wax or flammable solvents will create a fire hazard.

Do not use heat for drying articles that contain plastic, foam, sponge rubber, or similarly textured rubber materials. Drying in a heated tumbler may damage plastics or rubber and also may be a fire hazard.

A program should be established for the inspection and cleaning of lint in the burner area, exhaust ductwork, and area around the back of the dryer. The frequency of inspection and cleaning can best be determined from experience at each location.

WARNING

The collection of lint in the burner area and exhaust ductwork can create a potential fire hazard.

For personal safety, the dryer must be electrically grounded in accordance with local codes and/or the National Electrical Code ANSI/NFPA NO. 70-LATEST EDITION, or in Canada, the Canadian Electrical Codes Parts 1 & 2 CSA C22.1-1990 or LATEST EDITION.

NOTE: Failure to electrically ground the dryer properly will void the warranty.

Under no circumstances should the dryer door switch, lint door switch, or heat safety circuit ever be disabled.

WARNING

Personal injury or fire could result should the dryer door switch, lint door switch, or heat safety circuit ever be disabled.

This dryer is not to be used in the presence of dry cleaning solvents or fumes.

Remove articles from the dryer as soon as the drying cycle has been completed.

WARNING

Articles left in the dryer after the drying and cooling cycles have been completed can create a fire hazard.

CAUTION: Label all wires prior to disconnection when servicing controls. Wiring errors cause improper and dangerous operation. Verify proper operation after servicing.

Read and follow all caution and direction labels attached to the dryer.

For safety, proper operation, and optimum performance, the dryer must not be operated with a load less than sixty-six percent, 23 lb (10.5 kg) of its rated capacity.

WARNING

You must disconnect and lockout the electric supply and the gas supply or the steam supply before any covers or guards are removed from the machine to allow access for cleaning, adjusting, installation, or testing of any equipment per OSHA standards.

IMPORTANT: The dryer must be installed in a location/ environment, which the ambient temperature remains between 40° F (4.44° C) and 130° F (54.44° C).

WARNING

Disconnect power before resetting the hi-limit. The hi-limit is located on the rear opening of the lint compartment. Press and release and the hi-limit will reset.

Specifications

MAXIMUM CAPACITY (DRY WEIGHT) PER POCKET		35 lb	15.88 kg
TUMBLER DIAMETER		30"	76.2 cm
TUMBLER DEPTH		30"	76.2 cm
TUMBLER VOLUME PER POCKET		12.27 cu ft	347.4 L
TUMBLER / DRIVE MOTOR PER POCKET		1/4 hp	0.19 kW
BLOWER / FAN MOTOR PER POCKET		1/2 hp	0.37 kW
DOOR OPENING (DIAMETER)		21-1/2"	54.6 cm
DOOR SILL HEIGHT TOP POCKET / BOTTOM POCKET		51-3/4" / 13-1/8"	131.4 cm / 33.3 cm
DRYERS PER 20' / 40' CONTAINER		14 / 28	
DRYERS PER 48' / 53' TRUCK		36 / 42	
GAS	VOLTAGE AVAILABLE	120-240V 1ø 2w	50/60 Hz
	APPROXIMATE NET WEIGHT	540 lb	245 kg
	APPROXIMATE SHIPPING WEIGHT	570 lb	259 kg
	AIRFLOW PER POCKET	450 cfm	12.74 cmm
	HEAT INPUT PER POCKET	72,000 Btu/hr	18,144 kcal/hr
	EXHAUST CONNECTION (DIAMETER) PER POCKET	6"	15.24 cm
	INLET PIPE CONNECTION PER DRYER	1/2" M.N.P.T.	

Shaded areas are stated in metric equivalents

6/15/12

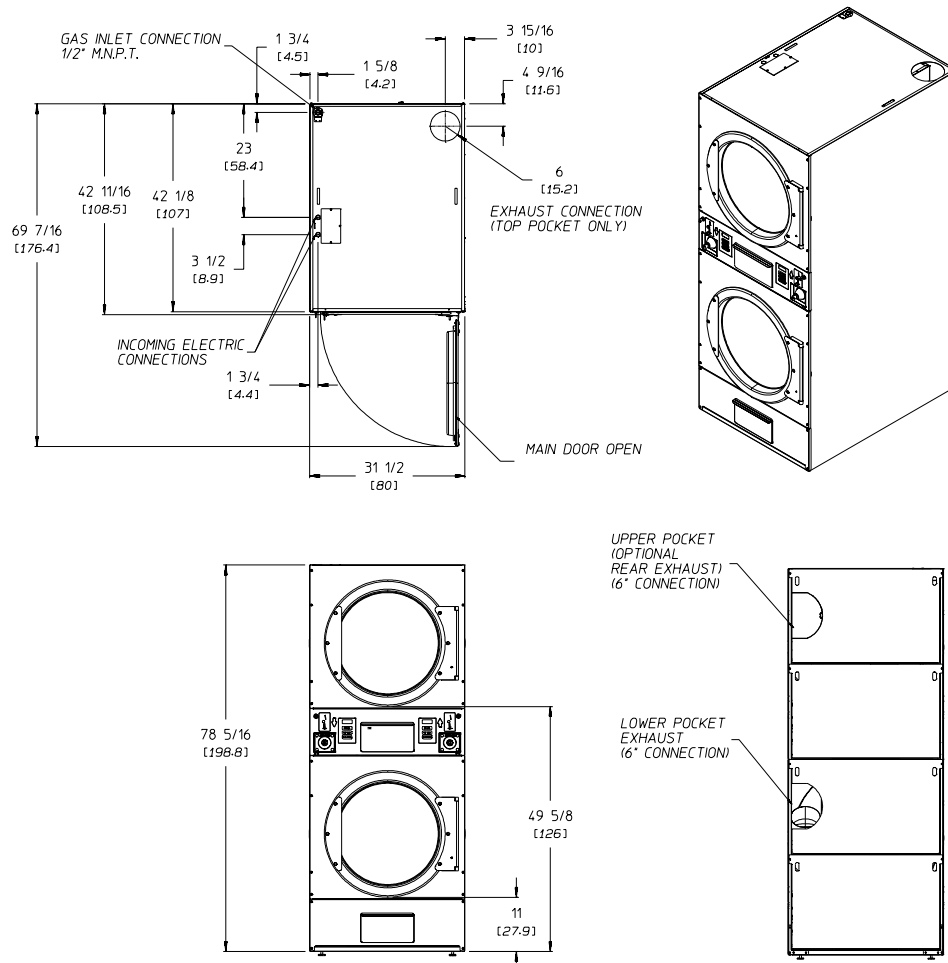

NOTE: The manufacturer reserves the right to make changes in specifications at any time without notice or obligation.

Installation Procedures

Installation should be performed by competent technicians in accordance with local and state codes. In the absence of these codes, the installation must conform to applicable American National Standards: ANSI.Z223.1-LATEST EDITION (National Fuel Gas Code) or ANSI/NFPA NO. 70-LATEST EDITION (National Electrical Code) or in Canada, the installation must conform to Canadian Standards: CAN/CGA-B149.1-M91 (Natural Gas) or CAN/CGA-B149.2-M91 (L.P. Gas) or LATEST EDITION (for General Installation and Gas Plumbing) or Canadian Electrical Codes Parts 1 & 2 CSA C22.1-1990 or LATEST EDITION (for Electrical Connections).

Unpacking / Setting Up

Remove protective shipping material (i.e., plastic wrap, and/or optional shipping box) from dryer.

The dryer can be moved to its final location while still attached to the pallet or with the pallet removed. To unpallet the dryer, locate and remove the four bolts securing the base of the dryer to the wooden pallet. Two are inside the lower back guard at the rear base and two are located at the front base. To remove the bolt located in the front, remove the lint door. Once the bolts are removed, slide the dryer off the pallet.

With the pallet removed, to make it easier to slide the dryer into its final position, slightly lower all four leveling legs, so that the dryer will slide on the legs instead of the base frame. The dryer is equipped with four leveling legs, one at each corner of the dryer base.

The dryer should be level side-to-side and front-to-rear.

Location of the Dryer

Before installing the dryer, be sure the location conforms to local codes and ordinances. In the absence of such codes or ordinances the location must conform with the National Fuel Gas Code ANSI.Z223.1 LATEST EDITION, or in Canada, the installation must conform to applicable Canadian Standards: CAN/CGA-B149.1-M91 (Natural Gas) or CAN/CGA-B149.2-M91 (L.P. Gas) or LATEST EDITION (for General Installation and Gas Plumbing).

The dryer must be installed on a sound level floor capable of supporting its weight. Carpeting must be removed from the floor area that the dryer is to rest on.

IMPORTANT: "The dryer must be installed on noncombustible floors only."

The dryer must not be installed or stored in an area where it will be exposed to water and/or weather.

The dryer is for use in noncombustible locations.

The dryer must be installed with provisions for adequate air supply as noted in this manual (refer to Fresh Air Supply Requirements section).

Clearance provisions must be made from noncombustible construction as noted in this manual (refer to Dryer Enclosure Requirements section).

Provisions must be made for adequate clearances for servicing and for operation as noted in this manual (refer to Dryer Enclosure Requirements section).

Dryer must be exhausted to the outdoors in an area where correct exhaust venting can be achieved as noted in this manual (refer to Exhaust Requirements section).

Dryer must be located in an area where correct exhaust venting can be achieved as noted in this manual (refer to Exhaust Requirements section).

IMPORTANT: Dryer must be installed in a location/ environment, which the ambient temperature remains between 40° F (4.44° C) and 130° F (54.44° C).

Dryer Enclosure Requirements

Bulkheads and partitions should be made of non-combustible materials and must be located a minimum of 12-inches (30.48 cm), 18-inches (45.72 cm) or more is recommended for ease of installation, maintenance, and service, above the dryer outer top, except along the front of the dryer, which may be closed in if desired. The clearance between the bulkhead header and the dryer must be a minimum of 4-inches (10.16 cm) and must not extend more than 4-inches (10.16 cm) to the rear of the front.

IMPORTANT: If the dryer is installed in a closet type enclosure there must be no other fuel burning appliance installed in the same closet.

Dryers may be positioned sidewall to sidewall. However, a 1/16" (1.5875 mm) minimum allowance must be made for opening and closing of the control door and the lint door. It is suggested that the dryer be positioned about 2 feet (0.61 meters) away from the nearest obstruction for ease of installation, maintenance, and service (to be measured from the back guard). Refer to the illustration below for details.

Clearances shown are minimum dimensions to nearest combustible materials.

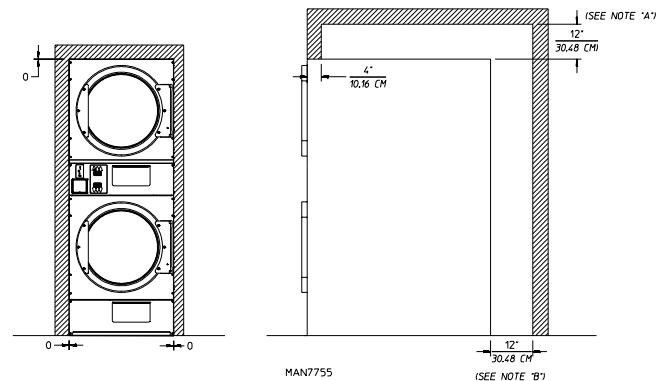

NOTE A: 12-inch (30.48 cm) minimum, 18-inches (45.7 cm) is suggested for ease of maintenance.

NOTE B: 12-inch (30.48 cm) minimum, 24-inches (61.0 cm) is suggested for ease of maintenance.

NOTE: Fresh air considerations are important for proper and efficient operation.

Fresh Air Supply Requirements

When the dryer is operating, it draws in room air, heats it, passes this air through the tumbler, and exhausts it out of the building. Therefore, the room air must be continually replenished from the outdoors. If the make-up air is inadequate, drying time and drying efficiency will be adversely affected. Ignition problems and sail switch "fluttering" problems may result, as well as premature motor failure from overheating. The dryer must be installed with provisions for adequate combustion and make-up air supply.

Air supply (make-up air) must be given careful consideration to ensure proper performance of each dryer. Fresh air ventilation openings shall not be blocked and/or sealed. As a general rule, an unrestricted air entrance from the outdoors of 144 inch² (929.03 cm²) is required. (Based on 1 inch² [6.5 cm²] per 1,000 Btu [252 kcal].)

It is not necessary to have a separate make-up air opening for each dryer. Common make-up air openings are acceptable. However, they must be set up in such a manner that the make-up air is distributed equally to all the dryers.

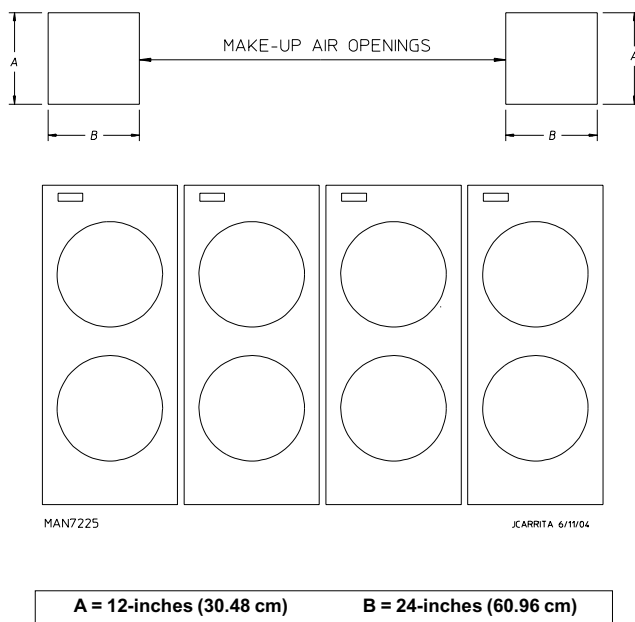

EXAMPLE: For a bank of 4 dryers, 2 unrestricted openings measuring 12-inches by 24-inches (30.48 cm by 60.96 cm) are acceptable.

To compensate for the use of registers or louvers used over the openings, this area must be increased by approximately 33%. Make-up air openings should not be located in an area directly near where exhaust vents exit the building.

Allowances must be made for remote or constricting passageways or where dryers are located at high altitudes or predominantly low pressure areas.

IMPORTANT: Make-up air must be free of dry cleaning solvent fumes. Make-up air that is contaminated by dry cleaning solvent fumes will result in irreparable damage to the motors and other dryer components.

NOTE: Component failure due to dry cleaning solvent fumes will void the warranty.

Exhaust Requirements

IMPORTANT: Dryer should be located where a minimum amount of exhaust duct will be necessary.

CAUTION: This dryer produces combustible lint and must be exhausted to the outdoors. Every six months, inspect the exhaust ducting and remove any lint buildup.

Exhaust ductwork should be designed and installed by a qualified professional. Improperly sized ductwork will create excessive back pressure, which results in slow drying, increased use of energy, overheating of the dryer, and shutdown of the burner by the airflow (sail) switches, burner hi-limits, or tumbler hi-limit thermostats. (Refer to the illustrations on the following page for details.) The dryer must be installed with a proper exhaust duct connection to the outside.

The design of the flue system shall be such that any condensate formed when operating the appliance from cold shall either be retained and subsequently re-evaporated or discharged.

CAUTION: This dryer produces combustible lint and must be exhausted to the outdoors.

Improperly sized or installed exhaust ductwork can create a potential fire hazard.

When possible, it is desirable to provide a separate exhaust air duct for each dryer. The duct should go as directly as possible to the outside air. Avoid sharp 90° right-angle turns in ducting; use 30° or 45° angles instead. The radius of the elbows should preferably be a minimum of 1-1/2 times the diameter of the duct. To protect the outside end of the duct from the weather, it may be bent downwards as indicated on the following page. Leave at least twice the diameter of the duct as clearance between the duct opening and the nearest obstruction. If the exhaust duct goes through the roof, it may be protected from the weather by using a 180° turn to point the opening down. Allow at least twice the diameter of the duct as clearance from the nearest obstruction.

Do not use screens, louvers, or caps on the outside opening of the exhaust ductwork. The ducting should be smooth inside with no projections from sheet metal screws or other obstructions, which will collect lint. Additionally, inspection doors should be installed at strategic points in the exhaust ductwork for periodic inspection and cleaning.

Inadequate exhaust facilities may cause high temperature limit switches or airflow switches to shut off the dryers. Do not disable the switches, which are provided for your safety. Instead, investigate the exhaust ducting. Any obstruction or air friction due to numerous elbows/fittings in the ducting will slow the passage of air through the system with resulting inefficiency and potential fire hazard.

IMPORTANT: Exhaust back pressure measured by a manometer at the dryer's exhaust duct area must be no less than 0 and must not exceed 0.6 in WC (1.48 mb).

NOTE: When the exhaust ductwork passes through a wall, ceiling, or roof made of combustible materials, the opening must be 2-inches (5.08 cm) larger than the duct (all the way around). The duct must be centered within this opening.

IMPORTANT: The dryer exhaust duct must not be connected to any gas vent, chimney, wall, ceiling, or concealing space of a building.

It is recommended that exhaust or booster fans not be used in the exhaust ductwork system.

As per the National Fuel Gas Code, "Exhaust ducts for type 2 clothes dryers shall be constructed of sheet metal or other noncombustible material. Such ducts shall be equivalent in strength and corrosion resistance to ducts made of galvanized sheet steel not less than 26 gauge (0.0195-inches [0.50 mm]) thick."

Single Pocket Venting (6" Duct)

IMPORTANT: A minimum exhaust duct size of 6-inches (15.24 cm) must be used.

For a 6-inch (15.24 cm) run where a maximum of two elbows are used (refer to the illustration below), the ductwork from the dryer outlet must not exceed 10 feet (3.0 meters).

This calculation of 10 feet (3.0 meters) compensates or allows for the use of a maximum of two elbows. Refer to the illustration below.

SINGLE POCKET VENTING (6" DUCT)

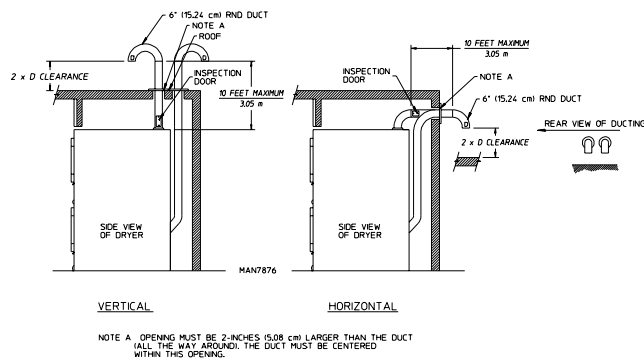

If the length of the duct run or quantity of elbows used exceeds the above noted specifications, the cross-sectional area of the ductwork may need to be increased.

IMPORTANT: For extended ductwork runs, the cross section area of the ductwork can only be increased to an extent. When the ductwork approaches the maximum limits noted in this manual, a professional HVAC firm should be consulted for proper venting information.

Single Dryer Venting (8" Duct)

IMPORTANT: A minimum exhaust duct size of 8-inches (20.3 cm) must be used.

For an 8-inch (20.3 cm) run where a maximum of two elbows are used (refer to the illustration below), the ductwork from the dryer outlet must not exceed 10 feet (3.0 meters).

This calculation of 10 feet (3.0 meters) compensates or allows for the use of a maximum of two elbows. Refer to the illustration below.

SINGLE DRYER VENTING (8" DUCT)

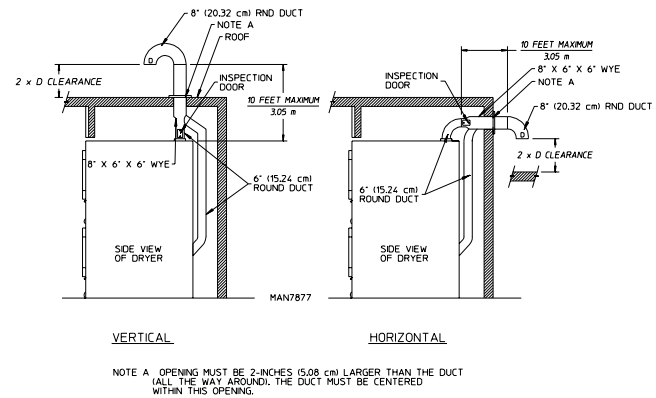

If the length of the duct run or quantity of elbows used exceeds the above noted specifications, the cross-sectional area of the ductwork may need to be increased.

IMPORTANT: For extended ductwork runs, the cross section area of the ductwork can only be increased to an extent. When the ductwork approaches the maximum limits noted in this manual, a professional HVAC firm should be consulted for proper venting information.

Single Dryer Venting (10" Duct)

IMPORTANT: A minimum exhaust duct size of 10-inches (25.4 cm) must be used for extended runs.

For a 10-inch (25.4 cm) run where a maximum of two elbows are used (refer to the illustration below), the ductwork from the dryer outlet must not exceed 45 feet (13.7 meters).

This calculation of 45 feet (13.7 meters) compensates or allows for the use of a maximum of two elbows. Refer to the illustration below.

SINGLE DRYER VENTING (10" DUCT)

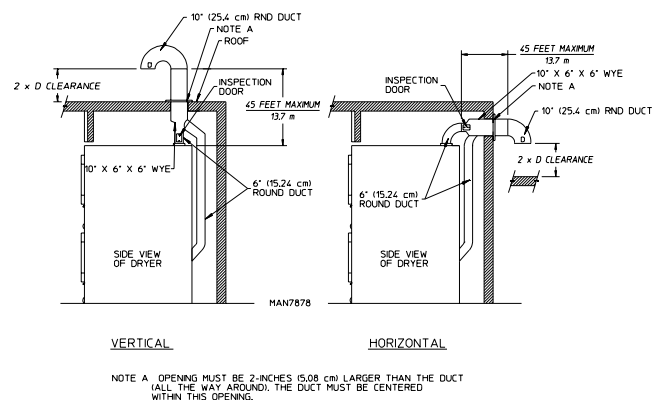

If the length of the duct run or quantity of elbows used exceeds the above noted specifications, the cross-sectional area of the ductwork may need to be increased.

IMPORTANT: For extended ductwork runs, the cross section area of the ductwork can only be increased to an extent. When the ductwork approaches the maximum limits noted in this manual, a professional HVAC firm should be consulted for proper venting information.

Multiple Dryer (Common) Venting

If it is not feasible to provide separate exhaust ducts for each dryer, ducts from individual dryers may be channeled into a "common main duct." The individual ducts should enter the bottom or side of the main duct at an angle not more than 45° in the direction of airflow. The main duct should be tapered, with the diameter increasing before each individual 10-inch (25.4 cm) duct (when dryer common exhaust is used) is added.

IMPORTANT: No more than four dryers or eight tumblers total should be connected to one main common duct.

The main duct may be any shape provided that the minimum cross-sectional area is maintained. The illustration below shows the minimum cross-sectional area for multiple dryer venting. These figures must be increased if the main duct run from the last dryer to where it exhausts to the outdoors is unusually long (over 30 feet [9.1 meters]) or has numerous elbows (more than one) in it.

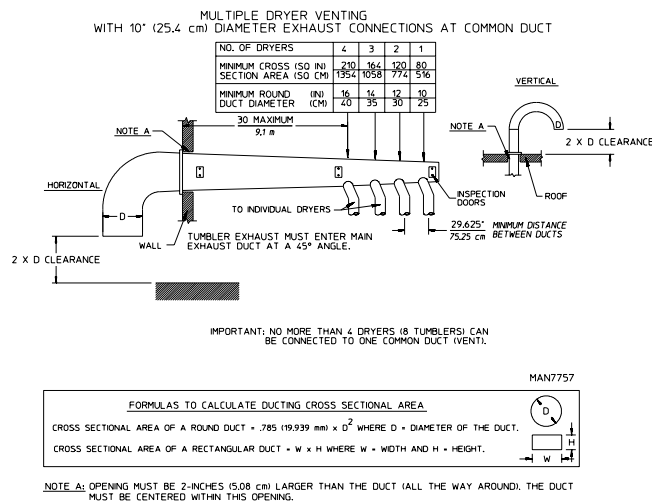

Electrical Information

Electrical Requirements

All electrical connections must be made by a properly licensed and competent electrician. This is to ensure that the electrical installation is adequate and conforms to local and state regulations or codes. In the absence of such codes, all electrical connections, materials, and workmanship must conform to the applicable requirements of the National Electrical Code ANSI/NFPA NO. 70-LATEST EDITION or in Canada, the Canadian Electrical Codes Parts 1 & 2 CSA C22.1-1990 or LATEST EDITION.

IMPORTANT: Failure to comply with these codes or ordinances, and/or the requirements stipulated in this manual can result in personal injury or component failure.

NOTE: Component failure due to improper installation will void the warranty.

Each dryer should be connected to an independently protected branch circuit (each pocket can be independently wired, if you prefer). The dryer must be connected with copper wire only. Do not use aluminum wire, which could cause a fire hazard. The copper conductor wire/cable must be of proper ampacity and insulation in accordance with electric codes for making all service connections.

NOTE: The use of aluminum wire will void the warranty.

IMPORTANT: A separate protected circuit must be provided to each dryer.

NOTE: An individual ground circuit must be provided to each dryer, do not daisy chain.

IMPORTANT: The dryer must be connected to the electric supply shown on the data label. In the case of 208 VAC or 240 VAC, the supply voltage must match the electric service specifications of the data label exactly. The amp draw listed on data plate is per pocket.

The wire size must be properly sized to handle the related current.

⚠ WARNING

208 VAC and 240 VAC are not the same. Any damage done to dryer components due to improper voltage connections will automatically void the warranty.

NOTE: Component failure due to improper voltage application will void the warranty.

The manufacturer reserves the right to make changes in specifications at any time without notice or obligation.

Electrical Service Specifications Gas Models Only

ELECTRICAL SERVICE SPECIFICATIONS (PER DRYER)					
IMPORTANT: 208 VAC AND 230/240 VAC ARE NOT THE SAME. When ordering, specify exact voltage.					
NOTES:					
A. When fuses are used they must be dual element, time delay, current limiting, class RK1 or RK5 ONLY. Calculate/determine correct fuse value, by applying either local and/or National Electrical Codes to listed appliance amp draw data.					
B. Circuit breakers are thermal-magnetic (industrial) motor curve type ONLY. For others, calculate/verify correct breaker size according to appliance amp draw rating and type of breaker used.					
C. Circuit breakers for 3-phase (3ø) dryers must be 3-pole type.					
SERVICE VOLTAGE	PHASE	WIRE SERVICE	APPROX. AMP DRAW		CIRCUIT BREAKER
			60 Hz	50 Hz	
120	1ø	2	14.2	—	20
120*	1ø	2	7.1	—	15 (2)
230	1ø	2	—	4.6	15
230	1ø	2	4.8	—	15

* Separate circuit for top and bottom pocket.

6/19/12

Grounding

A ground (earth) connection must be provided and installed in accordance with state and local codes. In the absence of these codes, grounding must conform to applicable requirements of the National Electrical Code ANSI/NFPA NO. 70-LATEST EDITION, or in Canada, the installation must conform to applicable Canada Standards: Canadian Electrical Codes Parts 1 & 2 CSA C22.1-1990 or LATEST EDITION. The ground connection may be to a proven earth ground at the location service panel.

For added personal safety, when possible, it is suggested that a separate ground wire (size per local codes) be connected from the ground connection of the dryer to a grounded cold water pipe. Do not ground to a gas pipe or hot water pipe. The grounded cold water pipe must have metal-to-metal connection all the way to the electrical ground. If there are any nonmetallic interruptions, such as, a meter, pump, plastic, rubber, or other insulating connectors, they must be jumped out with a wire (size per local codes) and securely clamped to bare metal at both ends.

IMPORTANT: For personal safety and proper operation, the dryer must be grounded.

Provisions are made for ground connection in each dryer at the electrical service connection area.

Electrical Connections

A wiring diagram is located inside the control box for connection data.

If local codes permit, power to the dryer can be made by the use of a flexible UL listed power cord/pigtail (wire size must conform to rating of dryer), or the dryer can be hard wired directly to the service breaker panel. In both cases, a strain relief must be installed where the wiring enters the dryer.

Gas Models Only

IMPORTANT: A separate protected circuit must be provided to each dryer.

Single-Phase (1Ø) Wiring Connections/Hookup

The electrical input connections on all single-phase (1Ø) gas dryers are made into the junction box located at the top left side area of the dryer (refer to page 5).

Electrical Connections Leads		
Black +	White -	Green
Positive	Neutral	Ground
(L1)	(L2)	(GND)

A ground wire is provided in the electrical box to connect your service ground.

Gas Information

It is your responsibility to have all plumbing connections made by a qualified professional to ensure that the gas plumbing installation is adequate and conforms to local and state regulations or codes. In the absence of such codes, all plumbing connections, materials, and workmanship must conform to the applicable requirements of the National Fuel Gas Code ANSI Z223.1-LATEST EDITION, or in Canada, the Canadian Installation Codes CAN/CGA-B149.1-M91 (Natural Gas) or CAN/CGA-B149.2-M91 (L.P. Gas) or LATEST EDITION.

IMPORTANT: Failure to comply with these codes or ordinances, and/or the requirements stipulated in this manual, can result in personal injury and improper operation of the dryer.

Each dryer must have its own manual shutoff valve to provide isolation of the dryer from the gas supply.

The dryer and its individual shutoff valve must be disconnected from the gas supply piping system during any pressure testing of that system at test pressures in excess of 1/2 psig (3.5 kPa). The dryer must be isolated from the gas supply piping system by closing its individual manual shutoff valve during any pressure testing of the gas supply system at test pressures equal to or less than 1/2 psig (3.5 kPa).

IMPORTANT: Failure to isolate or disconnect the dryer from supply as noted can cause irreparable damage to the gas valve voiding the warranty.

WARNING

Fire or explosion could result due to failure of isolating or disconnecting gas supply as noted.

Gas Supply

The gas dryer installation must meet the American National Standard...National Fuel Gas Code ANSI Z223.1-LATEST EDITION, or in Canada, the Canadian Installation Codes CAN/CGA-B149.1 M91 (Natural Gas) or CAN/CGA-B149.2-M91 (L.P. Gas) or LATEST EDITION, as well as local codes and ordinances and must be done by a qualified professional.

NOTE: Undersized gas piping will result in ignition problems, slow drying, increased use of energy, and can create a safety hazard.

The dryer must be connected to the type of heat/gas indicated on the dryer data label. If this information does not agree with the type of gas available, do not operate the dryer. Contact the reseller who sold the dryer or contact the manufacturer.

IMPORTANT: Any burner changes or conversions must be made by a qualified professional.

The input ratings shown on the dryer data label are for elevations up to 2,000 feet (610 meters), unless elevation requirements of over 2,000 feet (610 meters) were specified at the time the dryer order was placed with the factory. The adjustment or conversion of dryers in the field for elevations over 2,000 feet (610 meters) is made by changing each burner orifice. If this conversion is necessary, contact the reseller who sold the dryer or contact the manufacturer.

Technical Gas Data

Gas Specifications

Type of Gas	Manifold Pressure*	In-Line Pressure
Natural	3.5 in wc	6.0 - 12.0 in wc
	8.7 mb	14.92 - 29.9 mb
Liquid Propane	10.5 in wc	11.0 in wc
	26.1 mb	27.4 mb

Shaded areas are stated in metric equivalents

* Measured at outlet side of gas valve pressure tap when gas valve is on.

Gas Connections

Inlet connection 1/2" N.P.T. (1 per dryer)
 Inlet supply size 1/2" Pipe (minimum)
 Btu/hr input (per pocket) 72,000 (18,143 kcal/hr)

Natural Gas

Regulation is controlled by the dryer's gas valve's internal regulator. Incoming supply pressure must be consistent between a minimum of 6.0 in WC (14.92 mb) and a maximum of 12.0 in WC (29.9 mb) pressure.

L.P. Gas

Dryers made for use with L.P. gas have the gas valve's internal pressure regulator blocked open so that the gas pressure must be regulated upstream of the dryer. The pressure measured at each gas valve pressure tap must be a consistent 10.5 in WC (26.1 mb). There is no regulator or regulation provided in an L.P. dryer. The water column pressure must be regulated at the source (L.P. tank) or an external regulator must be added to each dryer.

		TYPE OF GAS (PER POCKET)					
Btu/hr Rating	kcal/hr Rating	Natural			Liquid Propane		
		Qty.	D.M.S.*	Part No.	Qty.	D.M.S.*	Part No.
72,000	18,143	1	#20	140908	1	#41	140909
Liquid Propane Conversion Kit Part Number 884439							

Shaded area is stated in metric equivalent

* D.M.S. equivalents are as follows:

Natural Gas #20 = 0.161" (4.089 mm).
 L.P. Gas #41 = 0.096" (2.438 mm).

Piping Connections

All components/materials must conform to National Fuel Gas Code Specifications ANSI Z223.1-LATEST EDITION, or in Canada, CAN/CGA-B149.1-M91 (Natural Gas) or CAN/CGA-B149.2-M91 (L.P. Gas) or LATEST EDITION (for General Installation and Gas Plumbing), as well as local codes and ordinances and must be done by a qualified professional. It is important that gas pressure regulators meet applicable pressure requirements, and that gas meters be rated for the total amount of all the appliance Btu being supplied.

The dryer is provided with one 1/2" N.P.T. inlet pipe connection extending out the top left corner of the dryer (refer to page 5).

It is recommended that a gas shutoff valve be provided to the gas supply line of each dryer for ease in servicing.

An 1/8" N.P.T. plugged tap, accessible for a test gauge connection, must be installed in the main gas supply line immediately upstream of each dryer.

IMPORTANT: Pipe joint compounds that resist the action of natural gas and L.P. gas must be used.

Test all connections for leaks by brushing on a soapy water solution (liquid detergent works well).

! WARNING

NEVER TEST FOR LEAKS WITH A FLAME!!!

The size of the main gas supply line (header) will vary depending on the distance this line travels from the gas meter or, in the case of L.P. gas, the supply tank, other gas-operated appliances on the same line, etc. Specific information regarding supply line size should be determined by the gas supplier.

NOTE: Undersized gas supply piping can create a low or inconsistent pressure, which will result in erratic operation of the burner ignition system.

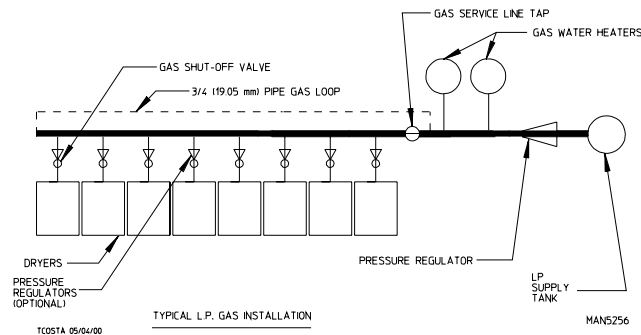
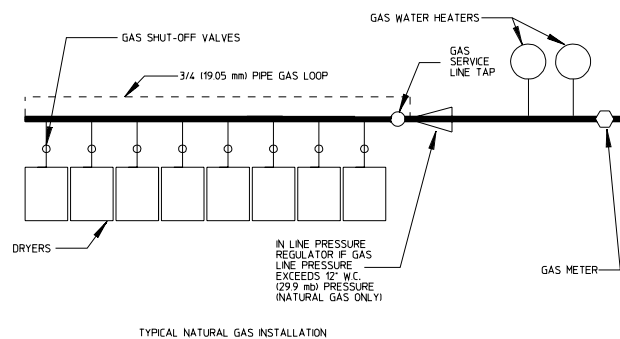

Preparation for Operation / Start-Up

The following items should be checked before attempting to operate the dryer:

Read all "CAUTION," "WARNING," and "DIRECTION" labels attached to the dryer.

Check incoming supply voltage to be sure that it is the same as indicated on the dryer data label.

Gas Models – check to ensure that the dryer is connected to the type of heat/gas indicated on the dryer data label.

The sail switch damper assembly was installed and adjusted at the factory prior to shipping. However, each sail switch adjustment must be checked to ensure that this important safety control is functioning.

Check bolts, nuts, screws, terminals, and fittings for tightness.

Gas Models – be sure that all gas shutoff valves are in the open position.

Be sure all back guard panels and service box covers have been replaced.

Check the lint door to ensure that it is closed and secured in place.

Rotate the tumbler by hand to be sure it moves freely.

Preoperational Test

All dryers are thoroughly tested and inspected before leaving the factory. However, a preoperational test should be performed before the dryer is publicly used. It is possible that adjustments have changed in transit or due to marginal location (installation) conditions. Installer must instruct the user on how to correctly operate the dryer before leaving.

Turn on electric power to the dryer.

Refer to the operating instructions for starting your particular model dryer.

Gas Dryers

When a gas dryer is first started (during initial start-up), it has a tendency not to ignite on the first ignition attempt. This is because the gas supply piping is filled with air, so it may take a few minutes for the air to be purged from the lines.

NOTE: During the purging period, check to be sure that all gas shutoff valves are open.

Gas model dryers are equipped with an ignition system, which has internal diagnostics. If ignition is not established after one time, the heat circuit in the ignition module will attempt two more ignitions (total of three ignition attempts). If there is no flame after the third ignition attempt, the module will lock out until it is manually reset. To reset the ignition system, open and close the main door and restart the dryer.

A burner gas pressure measurement should be taken at the gas valve outlet pressure tap of each gas valve to ensure that the water column pressure is correct and consistent.

NOTE: Water column burner pressure requirements (measured at the outlet pressure tap of the gas valve body):
Natural Gas 3.5 in WC (8.7 mb).
L.P. Gas 10.5 in WC (26.1 mb).

IMPORTANT: There is no regulator provided in an L.P. dryer. The water column pressure must be regulated at the source (L.P. tank) or an external regulator must be added to each dryer.

Make a complete operational check of all safety related circuits:

Door Switch(es)

Hi-Limit Thermostats

Cycling Thermostats

Sail Switch

Make a complete operational check of all operating controls.

NOTE: If computer program changes are required, refer to the computer programming section of the manual supplied with the dryer.

The dryer should be operated through one complete cycle to ensure that no further adjustments are necessary and that all components are functioning properly.

Tumbler Coating

The tumbler is treated with a protective coating. We suggest dampening old garments or cloth material with a solution of water and nonflammable mild detergent and tumbling them in the tumbler to remove this coating.

Preoperational Instructions

Coin Models

Microprocessor Controller (Computer)

When the microprocessor controller (computer) is in the ready state, the L.C.D. screen will display "FILL" followed by the amount to start.

Insert coin(s). Once the correct "Amount to Start" has been inserted, the L.C.D. will display "PUSH".

Select temperature by pressing "HI," "LO," or "PERM PRESS." The cycle will start and the L.C.D. will display the Dry Cycle selected and the remaining time.

The dryer will continue through the drying and cooling cycles, until the vended time has expired.

NOTE: To stop the dryer, open the main door. Continuation of the cycle will resume only after the door has been closed and any of the three temperature selection buttons is pressed.

Upon completion of the drying and cooling cycles, the tone (buzzer) will sound and the dryer will go into the Anti-Wrinkle Mode, if active, for up to 99 minutes, or until the main door or lint drawer has been opened.

IMPORTANT: For more detailed information regarding the microprocessor controller (computer) on your dryer, refer to the microprocessor user's manual included with the dryer.

Shutdown Instructions

If the dryer is to be shutdown (taken out of service) for a period of time, the following must be performed:

Discontinue power to the dryer either at the external disconnect switch or the circuit breaker.

Discontinue the gas supply (for gas models only):

Shut off external gas supply shutoff valve.

Service / Parts Information

Service

Service must be performed by a qualified trained technician, service agency, or gas supplier. If service is required, contact the reseller from whom the equipment was purchased. If the reseller cannot be contacted or is unknown, contact the Service Department for a reseller in your area.

NOTE: When contacting the Service Department, be sure to give them the correct model number and serial number so that your inquiry is handled in an expeditious manner.

Parts

Replacement parts should be purchased from the reseller from whom the equipment was purchased. If the reseller cannot be contacted or is unknown, contact the Parts Department for a reseller in your area. Parts may also be purchased directly from the factory by calling the Parts Department at (508) 678-9000, FAX in your order at (508) 678-9447, or visit us online at www.amdry.com.

NOTE: When ordering replacement parts from the reseller or the manufacturer, be sure to give them the correct model number and serial number so that your parts order can be processed in an expeditious manner.

Warranty Information

Warranty Registration

Visit us at www.amdry.com and register all of your new dryers by clicking on "Warranty" under the "Service" menu.

Warranty

For a copy of the commercial warranty covering your particular dryer(s), contact the reseller from whom you purchased the equipment and request a dryer warranty form. If the reseller cannot be contacted or is unknown, warranty information can be obtained from the factory by contacting the Warranty Department at (508) 678-9000.

NOTE: Whenever contacting the factory for warranty information, be sure to have the dryer's model number and serial number available so that your inquiry can be handled in an expeditious manner.

Returning Warranty Parts

All dryer or parts warranty claims or inquiries should be addressed to the Warranty Parts Department. To expedite processing, the following procedures must be followed:

No parts are to be returned without prior written authorization (R.M.A.) from the factory.

NOTE: An R.M.A. is valid for only 30 days from date of issue.

The R.M.A. issued by the factory, as well as any other correspondence pertaining to the returned part(s), must be included inside the package with the failed component.

Each part must be tagged with the following information:

Model number and serial number of the dryer from which part was removed.

Nature of failure (be specific).

Date of dryer installation.

Date of part failure.

Specify whether the part(s) being returned is for a replacement, a credit, or a refund.

NOTE: If a part is marked for a credit or a refund, the invoice number covering the purchase of the replacement part must be provided.

Warranty tags (PIN 450064) are available at "no charge" from ADC upon request.

The company returning the part(s) must clearly note the complete company name and address on the outside of the package.

All returns must be properly packaged to ensure that they are not damaged in transit. Damage claims are the responsibility of the shipper.

IMPORTANT: No replacements, credits, or refunds will be issued for merchandise damaged in transit.

All returns should be shipped to the ADC factory in such a manner that they are insured and a proof of delivery can be obtained by the sender.

Shipping charges are not the responsibility of ADC. All returns should be "prepaid" to the factory. Any "C.O.D." or "COLLECT" returns will not be accepted.

IMPORTANT: No replacements, credits, or refunds will be issued if the claim cannot be processed due to insufficient information. The party filing the claim will be notified in writing, either by "FAX" or "CERTIFIED MAIL – Return Receipt Requested," as to the information necessary to process claim. If reply is not received by the Warranty Department within 30 days from the FAX/letter date, then no replacements, credits, or refunds will be issued, and the merchandise will be discarded.

Routine Maintenance

Cleaning

A program and/or schedule should be established for periodic inspection, cleaning, and removal of lint from various areas of the dryer, as well as throughout the ductwork system. The frequency of cleaning can best be determined from experience at each location. Maximum operating efficiency is dependent upon proper air circulation. The accumulation of lint can restrict this airflow. If the guidelines in this section are met, an ADC dryer will provide many years of efficient, trouble free, and most importantly, safe operation.

WARNING

Lint from most fabrics is highly combustible. The accumulation of lint can create a potential fire hazard.

Keep dryer area clear and free from combustible materials, gasoline, and other flammable vapors and liquids.

NOTE: Suggested time intervals shown are for average usage, which is considered six to eight operational (running) hours per day.

IMPORTANT: Dryers produce combustible lint and must be exhausted to the outdoors. Every six months, inspect the exhaust ducting and remove any lint buildup.

Suggested Cleaning Schedule

Every Third or Fourth Load

Clean the lint drawer screen every third or fourth load. A clogged lint screen will cause poor dryer performance. Inspect the lint screen and replace if torn.

NOTE: The frequency of cleaning the lint screen can best be determined from experience at each location.

Weekly

Clean lint accumulation from the lint chamber, thermostat, and microprocessor temperature sensor (sensor bracket) area.

! WARNING

To avoid the hazard of electrical shock, discontinue electrical supply to the dryer.

90 Days

Remove lint from around tumbler, drive motor, and surrounding areas.

Remove lint from the gas valve burner area with a dusting brush or vacuum cleaner attachment.

Clean any lint accumulation in and around both the blower and drive motor casing openings.

NOTE: To prevent damage, avoid cleaning and/or touching ignitor/ flame-probe assembly.

Every Six Months

Inspect and remove lint accumulation in customer furnished exhaust ductwork system and from dryer's internal exhaust ducting.

NOTE: The accumulation of lint in the exhaust ductwork can create a potential fire hazard.

Do not obstruct the flow of combustion and ventilation air. Check customer furnished back draft dampers in the exhaust ductwork. Inspect and remove any lint accumulation, which can cause the damper to bind or stick.

A back draft damper that is sticking partially closed can result in slow drying and shutdown of heat circuit safety switches or thermostats.

If the hi-limit trips due to a high temperature occurrence, you must disconnect power before resetting. To reset, press and release the reset button, which is located in the lint compartment of the dryer.

When cleaning the dryer cabinet(s), avoid using harsh abrasives. A product intended for the cleaning of appliances is recommended.

Adjustments

7 Days After Installation and Every Six Months Thereafter

Inspect bolts, nuts, screws, setscrews, grounding connections, and nonpermanent gas connections (unions, shutoff valves, and orifices). Motor and drive belt should be examined. Cracked or seriously frayed belt should be replaced. Tighten loose belts when necessary. Complete operational check of controls and main valves. Complete operational check of all safety devices (door switch, lint drawer switch, sail switch, burner and exhaust hi-limit thermostats).

Data Label Information

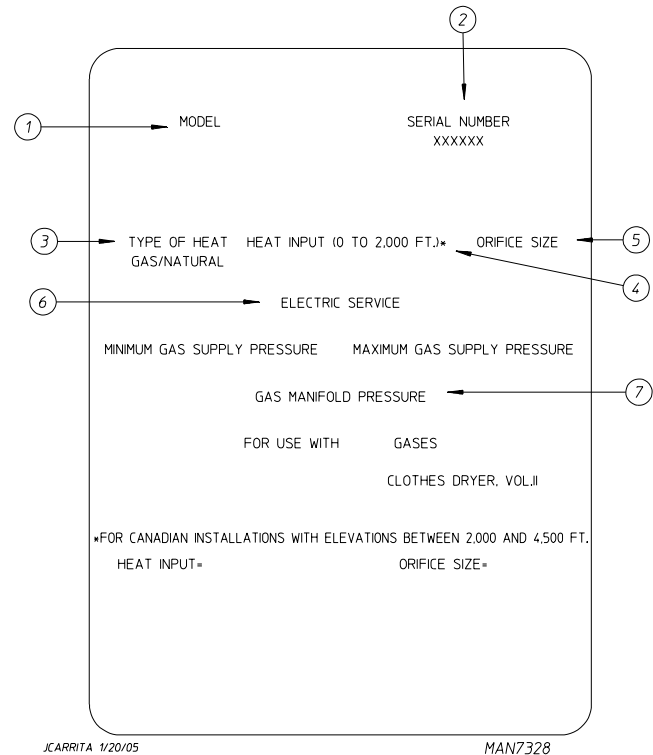

When contacting ADC, certain information is required to ensure proper service/parts information from ADC. This information is on the data label affixed to the right side panel area at the rear of the dryer. When contacting ADC, please have the model number and serial number available.

1. **MODEL NUMBER** – This describes the style of dryer and type of heat (gas, electric, or steam).
2. **SERIAL NUMBER** – Allows the manufacturer to gather information on your particular dryer.
3. **TYPE OF HEAT** – This describes the type of heat for your particular dryer, gas (either natural gas or L.P. gas), electric, or steam.
4. **HEAT INPUT** (For Gas Dryers) – This describes the heat input in British thermal units per hour (Btu/hr) or kilowatts (kW).
5. **ORIFICE SIZE** (For Gas Dryers) – Gives the number drill size used.
6. **ELECTRIC SERVICE** – This describes the voltage and current rating for a particular model.
7. **GAS MANIFOLD PRESSURE** (For Gas Dryers) – This describes the manifold pressure taken at the gas valve tap.

