

AD-210 Installation Manual

Phase 7 / Non-Coin / 650,000 Btu/hr with Non-Tilting Options

WARNING: For your safety the information in this manual must be followed to minimize the risk of fire or explosion and to prevent property damage, personal injury or death.

— Do not store or use gasoline or other flammable vapors and liquids in the vicinity of this or any other appliance.

— **WHAT TO DO IF YOU SMELL GAS:**

- Do not try to light any appliance.
- Do not touch any electrical switch; do not use any phone in your building.
- Clear the room, building or area of all occupants.
- Immediately call your gas supplier from a neighbor's phone. Follow the gas supplier's instructions.
- If you cannot reach your gas supplier, call the fire department.

— Installation and service must be performed by a qualified installer, service agency or the gas supplier.

AVERTISSEMENT: Assurez-vous de bien suivre les instructions données dans cette notice pour réduire au minimum le risque d'incendie ou d'explosion ou pour éviter tout dommage matériel, toute blessure ou la mort.

— Ne pas entreposer ni utiliser d'essence ni d'autres vapeurs ou liquides inflammables à proximité de cet appareil ou de tout autre appareil.

— **QUE FAIRE SI VOUS SENTEZ UNE ODEUR DE GAZ:**

- Ne pas tenter d'allumer d'appareils.
- Ne touchez à aucun interrupteur. Ne pas vous servir des téléphones se trouvant dans le bâtiment.
- Évacuez la pièce, le bâtiment ou la zone.
- Appelez immédiatement votre fournisseur de gaz depuis un voisin. Suivez les instructions du fournisseur.
- Si vous ne pouvez rejoindre le fournisseur de gaz, appelez le service des incendies.

— L'installation et l'entretien doivent être assurés par un installateur ou un service d'entretien qualifié ou par le fournisseur de gaz.



American Dryer Corporation

88 Currant Road

Fall River MA 02720-4781 USA

Telephone: +1 (508) 678-9000 / Fax: +1 (508) 678-9447

e-mail: techsupport@amdry.com

www.adclaundry.com

Retain This Manual in a Safe Place for Future Reference

This product embodies advanced concepts in engineering, design, and safety. If this product is properly maintained, it will provide many years of safe, efficient, and trouble free operation.

Only qualified technicians should service this equipment.

OBSERVE ALL SAFETY PRECAUTIONS displayed on the equipment or specified in the installation manual included with the dryer.

The following **“FOR YOUR SAFETY”** caution must be posted near the dryer in a prominent location.

FOR YOUR SAFETY

Do not store or use gasoline or other flammable vapors and liquids in the vicinity of this or any other appliance.

POUR VOTRE SÉCURITÉ

Ne pas entreposer ni utiliser d'essence ni d'autres vapeurs ou liquides inflammables à proximité de cet appareil ou de tout autre appareil.

We have tried to make this manual as complete as possible and hope you will find it useful. The manufacturer reserves the right to make changes from time to time, without notice or obligation, in prices, specifications, colors, and material, and to change or discontinue models. The illustrations included in this manual may not depict your particular dryer exactly.

IMPORTANT

For your convenience, log the following information:

DATE OF PURCHASE _____ MODEL NO. **AD-210 Non-Tilt**

RESELLER'S NAME _____

SERIAL NUMBER(S) _____

Replacement parts can be obtained from your reseller or the ADC factory. When ordering replacement parts from the factory, you can FAX your order to ADC at +1 (508) 678-9447 or telephone your order directly to the ADC Parts Department at +1 (508) 678-9000. Please specify the dryer model number and serial number in addition to the description and part number, so that your order is processed accurately and promptly.

These instructions are only valid if the following country code is on the appliance... If this code is not present on the appliance, it is necessary to refer to the technical instructions which will provide the necessary information concerning the modification of the appliance to the condition of use for the country.

In accordance with EN ISO 3166-1, the names of countries shall be represented by the following codes:

GB United Kingdom
IE Ireland

“IMPORTANT NOTE TO PURCHASER”

Information must be obtained from your local gas supplier on the instructions to be followed if the user smells gas. These instructions must be posted in a prominent location near the dryer.

⚠ WARNING

Proposition 65

Use of this product could expose you to substances from fuel combustion that contain chemicals known to the State of California to cause cancer, birth defects and other reproductive harm.

In the State of Massachusetts, the following installation instructions apply:

- Installations and repairs must be performed by a qualified or licensed contractor, plumber, or gasfitter qualified or licensed by the State of Massachusetts.
- If using a ball valve, it shall be a T-handle type.
- A flexible gas connector, when used, must not exceed 3 feet.

IMPORTANT

YOU MUST DISCONNECT AND LOCKOUT THE ELECTRIC SUPPLY AND THE GAS SUPPLY OR THE STEAM SUPPLY BEFORE ANY COVERS OR GUARDS ARE REMOVED FROM THE MACHINE TO ALLOW ACCESS FOR CLEANING, ADJUSTING, INSTALLATION, OR TESTING OF ANY EQUIPMENT PER OCCUPATIONAL SAFETY AND HEALTH ADMINISTRATION (OSHA) STANDARDS.

“Caution: Label all wires prior to disconnection when servicing controls. Wiring errors can cause improper operation.”

«Attention: Au moment de l'entretien des commandes, étiquetez tous les fils avant de les débrancher. Des erreurs de câblage peuvent entraîner un fonctionnement inadéquat et dangereux.»

CAUTION

DRYERS SHOULD NEVER BE LEFT UNATTENDED WHILE IN OPERATION.

WARNING

CHILDREN SHOULD NOT BE ALLOWED TO PLAY ON OR NEAR THE DRYERS.

CHILDREN SHOULD BE SUPERVISED IF NEAR DRYERS IN OPERATION.

FOR YOUR SAFETY

DO NOT DRY MOP HEADS IN THE DRYER.

DO NOT USE DRYER IN THE PRESENCE OF DRY CLEANING FUMES.

WARNING

UNDER NO CIRCUMSTANCES should the dryer door switches, lint drawer switch, heat safety circuit ever be disabled.

Do not modify this appliance.

The dryer *must never be* operated with any of the back guards, outer tops, or service panels removed. PERSONAL INJURY OR FIRE COULD RESULT.

DRYER MUST NEVER BE OPERATED WITHOUT THE LINT FILTER/SCREEN IN PLACE, EVEN IF AN EXTERNAL LINT COLLECTION SYSTEM IS USED.

IMPORTANT

PLEASE OBSERVE ALL SAFETY PRECAUTIONS displayed on the equipment and/or specified in the installation manual included with the dryer.

Dryer ***must not be*** installed or stored in an area where it **will be** exposed to water or weather.

The wiring diagram for the dryer is located in the front electrical control box area.

IMPORTANT

Dryer *must be* installed in a location/environment, which the ambient temperature remains between 40° F (4.44° C) and 130° F (54.44° C).

Table of Contents

SECTION I	
IMPORTANT INFORMATION.....	3
A. Receiving and Handling	3
B. Safety Precautions	4
SECTION II	
SPECIFICATIONS/DIMENSIONS AND COMPONENT LOCATION	7
A. Specifications (Gas and Steam)	7
B. Dimensions and Component Location	8
SECTION III	
INSTALLATION PROCEDURES	10
A. Reassembly of Dryer	10
B. Location Requirements	15
C. Fresh Air Supply Requirements	16
D. Exhaust Requirements.....	17
E. Compressed Air Supply System.....	23
F. Electrical Information	25
G. Gas Information	29
H. Water Supply Connection for Sensor Activated Fire Extinguishing (S.A.F.E.) System	32
I. Steam Information	33
J. Preoperational Test	38
K. Preparation for Operation / Start-Up	40
L. Shutdown Instructions	41
SECTION IV	
SERVICE / PARTS INFORMATION	42
A. Service	42
B. Parts	42
SECTION V	
WARRANTY INFORMATION	43
A. Returning Warranty Cards.....	43
B. Warranty	43
C. Returning Warranty Parts.....	43

SECTION VI	
ROUTINE MAINTENANCE	45
A. Cleaning	45
B. Adjustments	47
C. Lubrication.....	47
SECTION VII	
COMPONENT SYSTEM DESCRIPTIONS	48
A. Tumbler Drive System.....	48
B. Tumbler	49
C. Air Blower Drive System	49
D. Safety Devices	49
E. Steam Damper Actuator System	51
SECTION VIII	
MANUAL RESET BURNER HI-LIMIT INSTRUCTIONS	52
SECTION IX	
DATA LABEL INFORMATION	53
SECTION X	
PROCEDURE FOR FUNCTIONAL CHECK OF REPLACEMENT COMPONENTS	54
SECTION XI	
OPTIONAL SENSOR ACTIVATED FIRE EXTINGUISHING (S.A.F.E.) SYSTEM	55
SECTION XII	
NON-COIN PROGRAMMING	60

SECTION I

IMPORTANT INFORMATION

A. RECEIVING AND HANDLING

The dryer is shipped in a protective stretch wrap cover with protective cardboard corners and top cover (or optional box) as a means of preventing damage in transit. Upon delivery, the dryer and/or packaging, and wooden skid **should be** visually inspected for shipping damage. If any damage whatsoever is noticed, inspect further before delivering carrier leaves.

Dryers damaged in shipment:

1. **ALL** dryers **should be** inspected upon receipt and before they are signed for.
2. If there is suspected damage or actual damage, the trucker's receipt **should be** so noted.
3. If the dryer is damaged beyond repair, it **should be** refused. Those dryers, which were not damaged in a damaged shipment **should be** accepted, but the number received and the number refused **must be** noted on the receipt.
4. If you determine that the dryer was damaged after the trucker has left your location, you should call the delivering carrier's freight terminal immediately and file a claim. The freight company considers this concealed damage. This type of freight claim is very difficult to get paid and becomes extremely difficult when more than a day or two passes after the freight was delivered. It is your responsibility to file freight claims. Dryer/parts damaged in transit **cannot** be claimed under warranty.
5. Freight claims are the responsibility of the consignee, and **ALL** claims **must be** filed at the receiving end. **ADC** assumes no responsibility for freight claims or damages.
6. If you need assistance in handling the situation, please contact the **ADC** Traffic Manager at +1 (508) 678-9000.

IMPORTANT: The tumbler section of the dryer **must be** transported and handled in an upright position at **ALL** times.

B. SAFETY PRECAUTIONS

WARNING: For your safety, the information in this manual *must be* followed to minimize the risk of fire or explosion or to prevent property damage, personal injury, or loss of life.

WARNING: The dryer *must never be* operated with any of the back guards, outer tops, or service panels removed. **PERSONAL INJURY OR FIRE COULD RESULT.**

1. **DO NOT** store or use gasoline or other flammable vapors and liquids in the vicinity of this or any other appliance.
2. **DO NOT** spray aerosols in the vicinity of this appliance while it is in operation.
3. Purchaser/user should consult the local gas supplier for proper instructions to be followed in the event the user smells gas. The instructions **should be** posted in a prominent location.
4. WHAT TO DO IF YOU SMELL GAS...
 - a. **DO NOT** try to light any appliance.
 - b. **DO NOT** touch any electrical switch.
 - c. **DO NOT** use any phone in your building.
 - d. Clear the room, building, or area of **ALL** occupants.
 - e. Immediately call your gas supplier from a neighbor's phone. Follow the gas supplier's instructions.
 - f. If you **cannot** reach your gas supplier, call the fire department.
5. Installation and service **must be** performed by a qualified installer, service agency, or gas supplier.
6. Dryer(s) **must be** exhausted to the outdoors.
7. Although ADC produces a very versatile dryer, there are some articles that, due to fabric composition or cleaning method, **should not be** dried in it.

WARNING: Dry only water washed fabrics. **DO NOT** dry articles spotted or washed in dry cleaning solvents, a combustible detergent, industrial chemicals, or "all purpose" cleaner. **EXPLOSION COULD RESULT.**

WARNING: **DO NOT** dry rags or articles coated or contaminated with gasoline, kerosene, oil, paint, or wax. **EXPLOSION COULD RESULT.**

WARNING: **DO NOT** dry mop heads. Contamination by wax or flammable solvents will create a fire hazard.

WARNING: **DO NOT** use heat for drying articles that contain plastic, foam, sponge rubber, or similarly textured rubber materials. Drying in a heated tumbler may damage plastics or rubber and may be a fire hazard.

8. The possible presence of residual quantities of aggressive or decomposed chemicals in the load may produce damage to the machine and harmful fumes.
9. A program **should be** established for the inspection and cleaning of lint in the heating unit area, exhaust ductwork, and inside the dryer. The frequency of inspection and cleaning can best be determined from experience at each location.

WARNING: The collection of lint in the burner area and exhaust ductwork can create a potential fire hazard.

10. For personal safety, the dryer **must be** electrically grounded in accordance with local codes and/or the National Electrical Code ANSI/NFPA NO. 70-LATEST EDITION or in Canada, the Canadian Electrical Codes Parts 1 & 2 CSA C22.1-1990 or LATEST EDITION.

NOTE: Failure to do so will VOID THE WARRANTY.

11. **UNDER NO CIRCUMSTANCES** should the dryer door switches, lint drawer switch, heat safety circuit ever be disabled.

WARNING: PERSONAL INJURY OR FIRE COULD RESULT.

12. This dryer is not to be used in the presence of dry cleaning solvents or fumes.
13. Remove articles from the dryer as soon as the drying cycle has been completed.

WARNING: Articles left in the dryer after the drying and cooling cycles have been completed can create a fire hazard.

14. **DO NOT** operate steam dryers with more than 125 PSI (8.62 bar) steam pressure. Excessive steam pressure can damage steam coil and/or harm personnel.
15. Replace leaking flexible hoses or other steam fixtures immediately. **DO NOT** operate the dryer with leaking flexible hoses. **PERSONAL INJURY MAY RESULT.**
16. **READ AND FOLLOW ALL CAUTION AND DIRECTION LABELS ATTACHED TO THE DRYER.**
17. For safety, proper operation, and optimum performance, the dryer **must not be** operated with a load less than sixty-six percent (66%), 132 lb (59.9 kg) of its rated capacity.

WARNING: YOU MUST DISCONNECT AND LOCKOUT THE ELECTRIC SUPPLY AND THE GAS SUPPLY OR THE STEAM SUPPLY BEFORE ANY COVERS OR GUARDS ARE REMOVED FROM THE MACHINE TO ALLOW ACCESS FOR CLEANING, ADJUSTING, INSTALLATION, OR TESTING OF ANY EQUIPMENT PER OSHA (Occupational Safety and Health Administration) STANDARDS.

IMPORTANT: Dryer *must be* installed in a location/environment, which the ambient temperature remains between 40° F (4.44° C) and 130° F (54.44° C).

CE ONLY

IMPORTANT: This appliance must only be installed and operated in the country of destination indicated on the dryer's data plate. If the appliance is to be installed and operated in a country other than the one indicated on the data plate, a data plate amendment must be obtained from American Dryer Corporation.

IEC335 applies.

NOTES _____

SECTION II

SPECIFICATIONS / DIMENSIONS

AND COMPONENT LOCATION

A. SPECIFICATIONS (GAS AND STEAM)

MAXIMUM CAPACITY (DRY WEIGHT)		200 lb	90.72 kg
TUMBLER DIAMETER		62-1/2"	158.75 cm
TUMBLER DEPTH		42"	106.7 cm
TUMBLER VOLUME		74.5 cu ft	2,109.60 L
TUMBLER / DRIVE MOTOR		3 hp	2.24 kW
DOOR OPENING *		36-3/4" w x 43" h	93.3 cm x 109.2 cm
DOOR SILL HEIGHT – LEVEL		36-1/2"	92.7 cm
COMPRESSED AIR VOLUME		3.25 cfh	0.09 cmh
COMPRESSED AIR CONNECTION **		1/8" F.N.P.T.	
EXHAUST CONNECTION (DIAMETER)		20"	50.8 cm
WATER CONNECTION ***		3/4" F.N.P.T.	
GAS	VOLTAGE AVAILABLE	208-575V 3ø 3,4w 50/60 Hz	
	BLOWER / FAN MOTOR (REAR / SIDE EXHAUST)	7-1/2 hp / 15 hp	5.6 kW / 11.2 kW
	APPROXIMATE NET WEIGHT	3,033 lb	1,376 kg
	APPROXIMATE SHIPPING WEIGHT	3,195 lb	1,449 kg
	HEAT INPUT	650,000 Btu/hr	163,810 kcal/hr
	AIRFLOW 50/60 Hz	5,300 cfm	150.08 cmm
	INLET PIPE CONNECTION	1-1/2" F.N.P.T.	
STEAM	VOLTAGE AVAILABLE	208-575V 3ø 3,4w 50/60 Hz	
	BLOWER / FAN MOTOR	15 hp	11.2 kW
	APPROXIMATE NET WEIGHT	3,275 lb	1,486 kg
	APPROXIMATE SHIPPING WEIGHT	3,437 lb	1,559 kg
	AIRFLOW 60 Hz	6,500 cfm	184.06 cmm
	AIRFLOW 50 Hz	5,417 cfm	153.38 cmm
	STEAM CONSUMPTION	890 lb/hr	404.5 kg/hr
	OPERATING STEAM PRESSURE	125 psi max	8.6 bar
	BOILER HORSEPOWER (NORMAL LOAD)	27 Bhp	
	SUPPLY CONNECTION	2" M.N.P.T.	
RETURN CONNECTION	2" M.N.P.T.		

Shaded areas are stated in metric equivalents

7/17/14

* Height is 43-inches (109.22 cm) maximum at the center of the door.

** Dryer must be provided with clean, dry and regulated 80 psi +/- 10 psi (5.51 bar +/- 0.69 bar) air supply.

*** Water supply must be 40 psi +/- 20 psi (2.75 bar +/- 1.37 bar) for fire suppression system to operate properly.

NOTE: ADC reserves the right to make changes in specifications at any time without notice or obligation.

B. DIMENSIONS AND COMPONENT LOCATION

AD-210* NON-TILT GAS MODEL

- * BOTH GAS AND STEAM UNITS MUST BE SUPPLIED WITH CLEAN, DRY, REGULATED AIR AT 80 PSI \pm 10 PSI (5.52 BAR \pm 0.69 BAR).
- ** DUCTWORK SIZE VARIES WITH INSTALLATION CONDITIONS. EXHAUST STATIC PRESSURE SHOULD NOT EXCEED 0.3" WATER COLUMN (0.74 mb).
- *** SIZE OF PIPING TO DRYER VARIES WITH INSTALLATION CONDITIONS. CONTACT FACTORY FOR ASSISTANCE.

AD-210* NON-TILT GAS MODEL

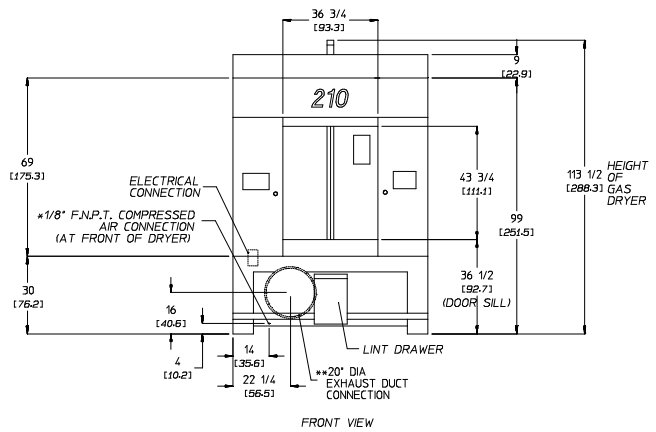
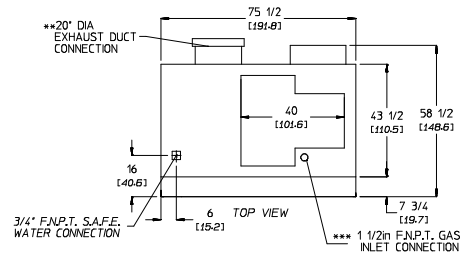
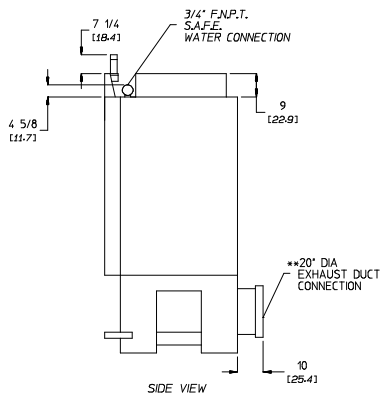

AD-210* NON-TILT STEAM MODEL

- * BOTH GAS AND STEAM UNITS MUST BE SUPPLIED WITH CLEAN, DRY, REGULATED AIR AT 80 PSI ± 10 PSI (5.52 BAR ± 0.69 BAR).
- ** DUCTWORK SIZE VARIES WITH INSTALLATION CONDITIONS. EXHAUST STATIC PRESSURE SHOULD NOT EXCEED 0.3" WATER COLUMN (0.74 mb).
- *** SIZE OF PIPING TO DRYER VARIES WITH INSTALLATION CONDITIONS. CONTACT FACTORY FOR ASSISTANCE.

AD-210* NON-TILT STEAM MODEL

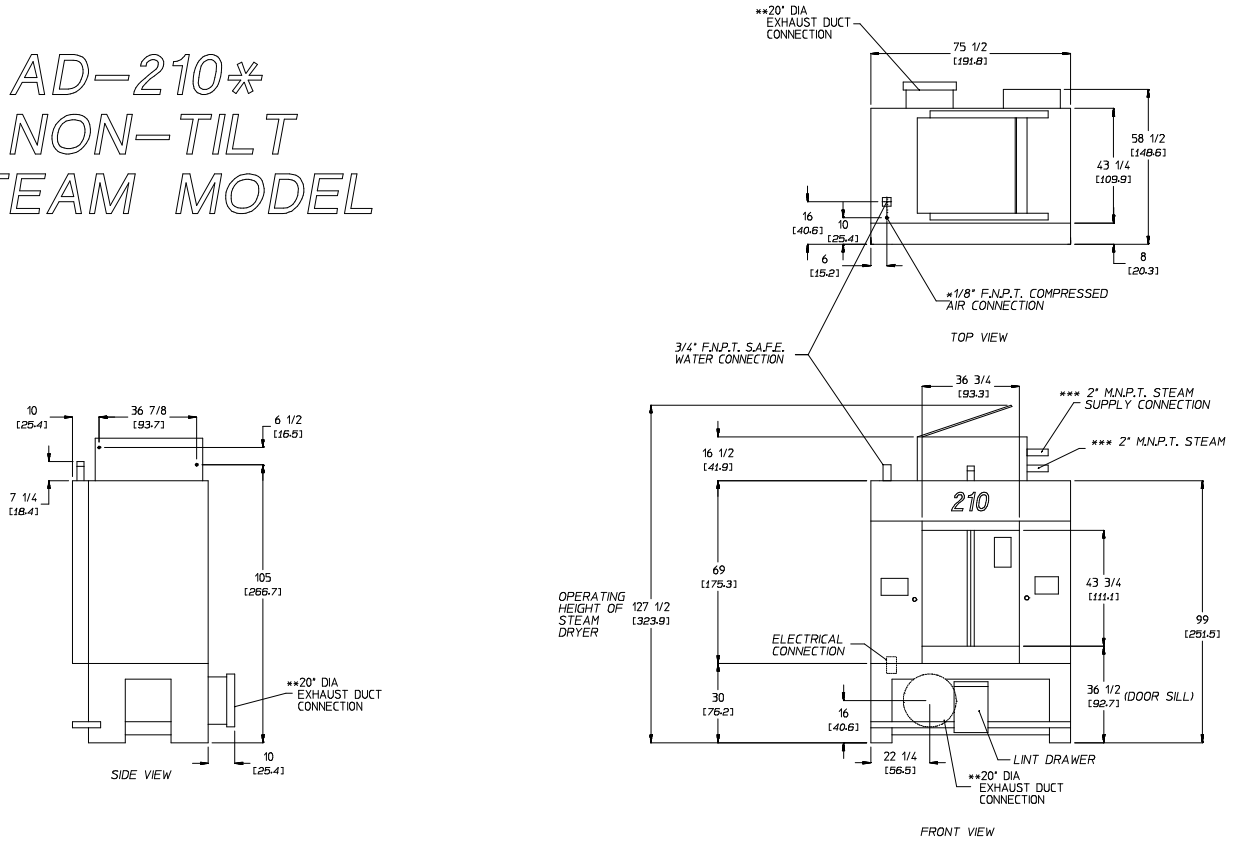

SECTION III

INSTALLATION PROCEDURES

Installation **should be** performed by competent technicians in accordance with local and state codes. In the absence of these codes, the installation **must conform** to applicable American National Standards: ANSI Z223.1-LATEST EDITION (National Fuel Gas Code) or ANSI/NFPA NO. 70-LATEST EDITION (National Electrical Code) or in Canada, the installation **must conform** to applicable Canadian Standards: CAN/CGA-B149.1-M91 (Natural Gas) or CAN/CGA-B149.2-M91 (Liquid Propane Gas) or LATEST EDITION (for General Installation and Gas Plumbing) or Canadian Electrical Codes Parts 1 & 2 CSA C22.1-1990 or LATEST EDITION (for Electrical Connections).

A. REASSEMBLY OF DRYER

IMPORTANT: Always keep the tumbler section of the dryer in an upright position when moving it.

The dryer may be shipped one (1) of two (2) ways; as a complete unit fully assembled and ready for hookup or with the tumbler section separated from the base. If the dryer is shipped in two (2) pieces, the tumbler section will have to be lifted onto the base. Use cables through the eyebolts on top of the tumbler section, or use a forklift for the lifting process.

1. Reassembly Instructions For Gas Dryer Shipped In Two (2) Pieces

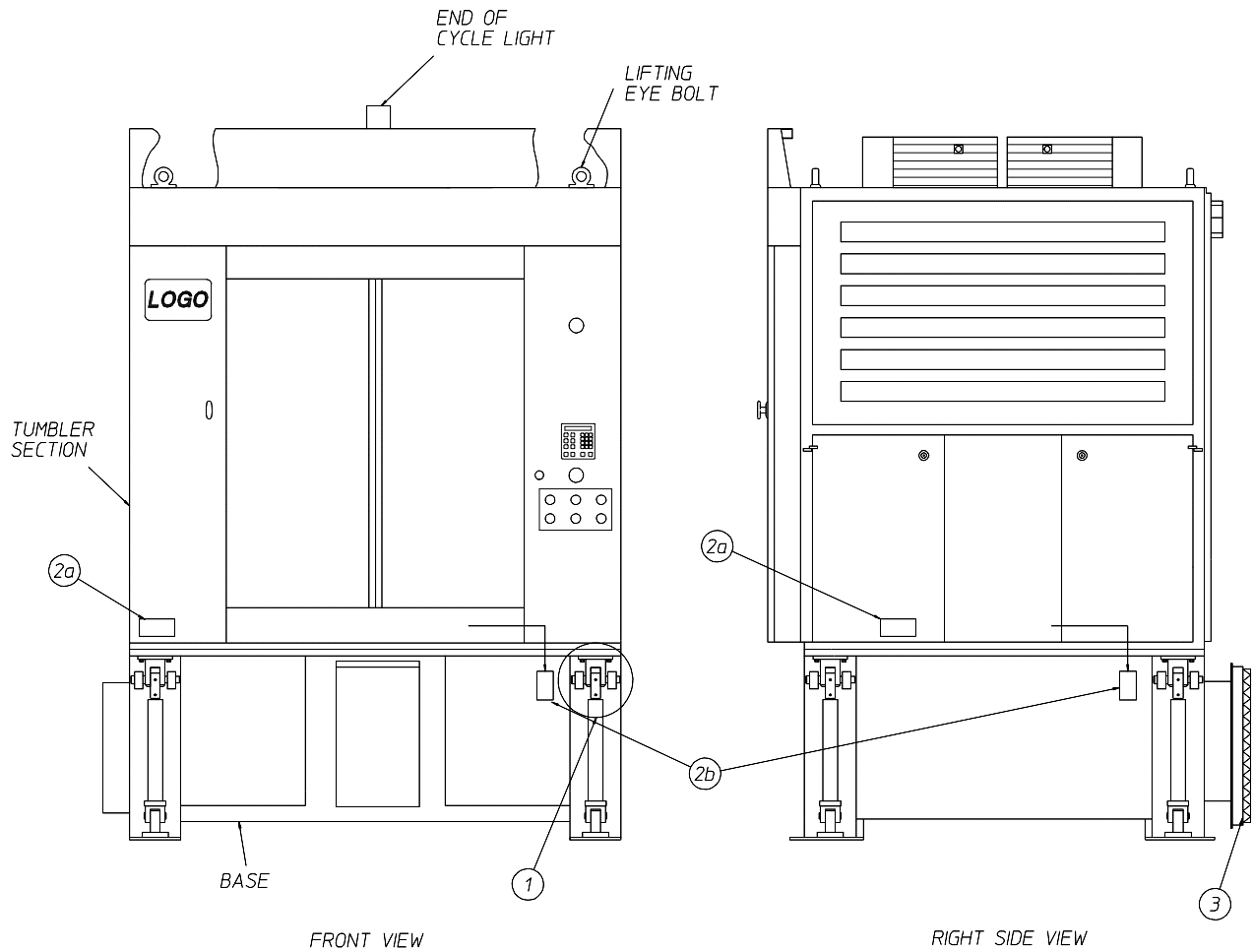

MAN5601

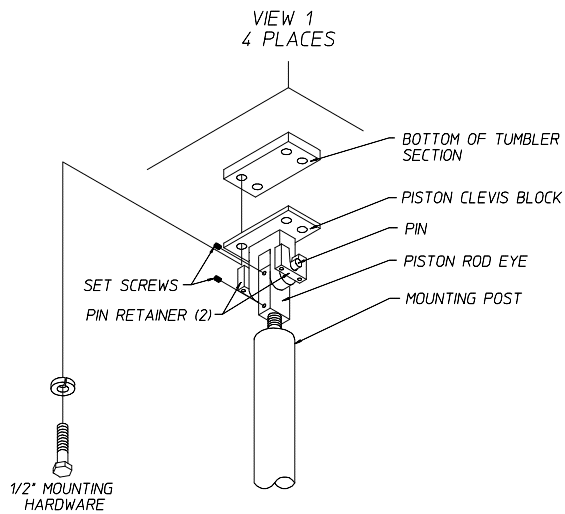

DMG 01/24/01

a. Reassembly Instructions For Non-Tilt Gas Dryers:

Lift the tumbler section onto the base.

- 1) The dryer has four (4) support posts assemblies, which are located in each corner of the base. On top of each post assembly is a clevis block, which **must be** bolted to the tumbler section. Use the 4-1/2" diameter x 1-1/8" long bolts and lock washers to bolt each clevis block to the tumbler section. (Refer to **View 1** on the previous page.)
- 2) Tumbler power cable reconnection:
 - a) A plug and cable is located in the right of the base. This **must be** lifted up and reconnected into the mating socket located at the bottom of the right tumbler section.
 - b) Pull the tumbler section power cable up from the left side of the base through the hole in the bottom of the tumbler section. Reconnect the wires of this cable into the 2-inch x 4-inch (5.08 cm x 10.16 cm) tumbler junction box located at the bottom of the tumbler section. (Refer to the **illustration** on the previous page.)
 - c) Drop the control cable connector from the rear right side of the tumbler section into the base. Reconnect the industrial grade plug in to its mating socket.
- 3) Bolt the 20-inch (50.8 cm) diameter exhaust duct transition piece to the dryers rectangular exhaust duct. The exhaust duct exits the dryer from the rear of the base. (Refer to the **illustration** on the previous page.) Use the 1/4-20 self-drilling screws supplied with the dryer.

2. Reassembly Instructions For Steam Dryer Shipped In Two (2) Pieces

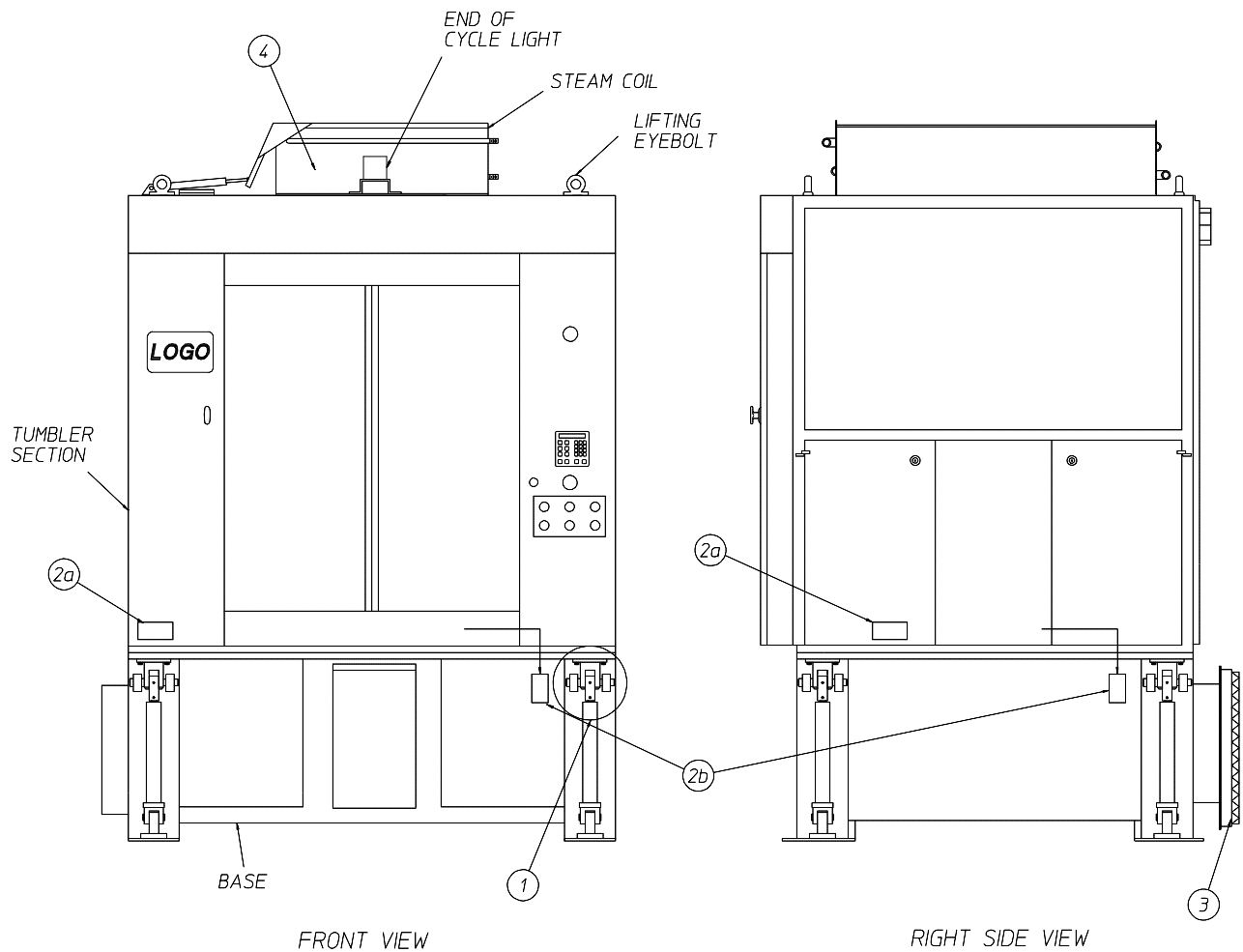

MAN5738

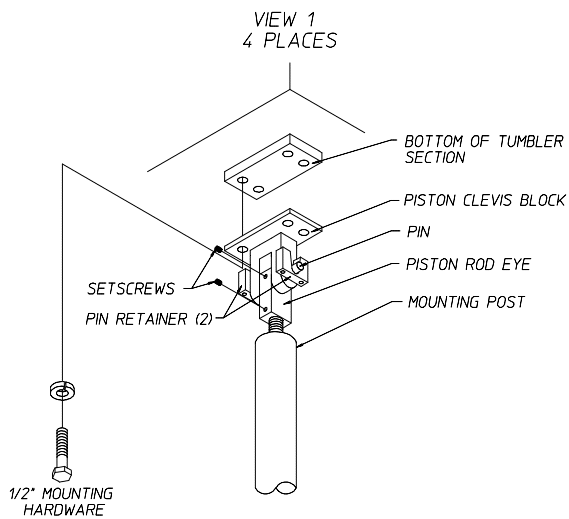

DMG 04/09/01

a. Reassembly Instructions For Non-Tilt Steam Dryers:

Lift the tumbler section onto the base.

- 1) The dryer has four (4) support posts assemblies, which are located in each corner of the base. On top of each post assembly is a clevis block, which **must be** bolted to the tumbler section. Use the 4-1/2" diameter x 1-1/8" long bolts and lock washers to bolt each clevis block to the tumbler section. (Refer to **View 1** on the previous page.)
- 2) Tumbler power cable reconnection:
 - a) A plug and cable is located in the right of the base. This **must be** lifted up and reconnected into the mating socket located at the bottom of the right tumbler section.
 - b) Pull the tumbler section power cable up from the left side of the base through the hole in the bottom of the tumbler section. Reconnect the wires of this cable into the 2-inch x 4-inch (5.08 cm x 10.16 cm) tumbler junction box located at the bottom of the tumbler section. (Refer to the **illustration** on the previous page.)
 - c) Drop the control cable connector from the rear right side of the tumbler section into the base. Reconnect the industrial grade plug in to its mating socket.
- 3) Bolt the 20-inch (50.8 cm) diameter exhaust duct transition piece to the dryers rectangular exhaust duct. The exhaust duct exits the dryer from the rear of the base. (Refer to the **illustration** on the previous page.) Use the 1/4-20 self-drilling screws supplied with the dryer.
- 4) If a steam dryer is shipped in two (2) pieces, the steam coil may have been removed from the top of the tumbler section and shipped with the base. If this is the case, lift the steam coil on to the top of the tumbler section with the steam pipe connections facing towards the right side of the dryer and bolt the coil to the top of the dryer with a 1/4-inch hardware supplied. There are three (3) panels that cover the front, right side, and rear of the steam coil. Fasten these in position also.

B. LOCATION REQUIREMENTS

Before installing the dryer, be sure the location conforms to local codes and ordinances. In the absence of such codes or ordinances the location **must conform** with the National Fuel Gas Code ANSI.Z223.1 LATEST EDITION, or in Canada, the installation **must conform** to applicable Canadian Standards: CAN/CGA-B149.1-M91 (Natural Gas) or CAN/CGA-B149.2-M91 (Liquid Propane Gas) or LATEST EDITION (for General Installation and Gas Plumbing).

The non-tilting model dryer requires 18-inches (45.72 cm) of space on each side of the dryer and 24-inches (60.96 cm) of space behind the unit for ease of service. A minimum of 12-inches (30.48 cm) **must be** allowed between the top of a gas dryer and the ceiling. A ceiling height of 120-inches (304.8 cm) is required for gas dryers, and a ceiling height for 130-inches (330.2 cm) is required for steam dryers. The dryer **must be** leveled for proper operation. If shimming is required, put metal shims which are the same size as the base feet under the base feet. The dryer **must be** lagged to the floor.

WARNING: Dryer *should be* located where a minimum length of exhaust duct **will be** necessary.

1. The dryer **must be** installed with a proper exhaust duct connection to the outside.
2. The dryer **must be** installed with provisions for adequate combustion and make-up air supply.

CAUTION: This dryer produces combustible lint and **must be** exhausted to the outdoors. Every 6 months, inspect the exhaust ducting and remove any lint build up.

IMPORTANT: Dryer **must be** installed in a location/environment, which the ambient temperature remains between 40° F (4.44° C) and 130° F (54.44° C).

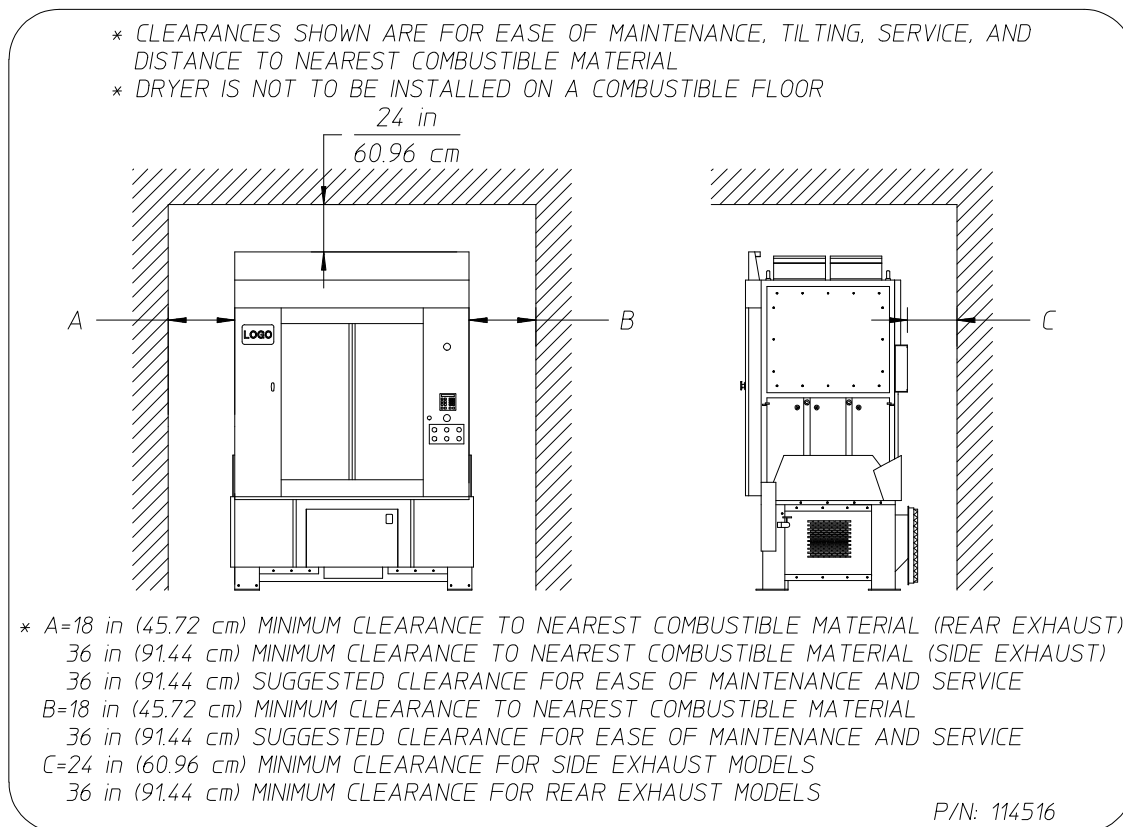

DMG 01/29/01

MAN5622

C. FRESH AIR SUPPLY REQUIREMENTS

This appliance may only be installed in a room that meets the appropriate ventilation requirements specified in the national installation regulations.

When the dryer is operating, it draws in room air, heats it, passes this air through the tumbler, and exhausts it out of the building. Therefore, the room air **must be** continually replenished from the outdoors. If the make-up air is inadequate, drying time and drying efficiency will be adversely affected. Ignition problems and sail switch “fluttering” problems may result, as well as premature motor failure from overheating.

Air supply (make-up air) **must be** given careful consideration to assure proper performance of each dryer. An unrestricted source of air is necessary for each dryer. An airflow of 5,300 cfm (cubic feet per minute) (150 cmm [cubic meters per minute]) **must be** supplied to each gas dryer and 6,500 cfm (184 cmm) for each steam dryer. As a general rule, an unrestricted air entrance from the outdoors (atmosphere) of a minimum of 6 square feet (0.56 square meters) is required for each gas dryer and a minimum of 8 square feet (0.74 square meters) for each steam dryer.

To compensate for the use of registers or louvers used over the openings, this make-up air area **must be** increased by approximately thirty-three percent (33%). Make-up air openings **should not be** located in an area directly near where exhaust vents exit the building.

It is not necessary to have a separate make-up air opening for each dryer. Common make-up air openings are acceptable. However, they **must be** set up in such a manner that the make-up air is distributed equally to **ALL** the dryers. The dryer **must be** installed with provisions for adequate combustion and make-up air supply.

Allowances **must be** made for remote or constricting passageways or where dryers are located at excessive altitudes or predominantly low pressure areas.

IMPORTANT: Make-up air **must be** provided from a source free of dry cleaning solvent fumes. Make-up air that is contaminated by dry cleaning solvent fumes will result in irreparable damage to the motors and other dryer components.

NOTE: Component failure due to dry cleaning solvent fumes will VOID THE WARRANTY.

D. EXHAUST REQUIREMENTS

NOTE: For 1 door dryers, the 20-inch (50.8 cm) diameter exhaust duct exits from the rear of the base. For 2 door dryers, the 20-inch (50.8 cm) diameter exhaust duct exits from the left side of the base.

1. General Exhaust Ductwork Information

Exhaust ductwork **should be** designed and installed by a qualified professional. Improperly sized ductwork will create excessive back pressure which results in slow drying, increased use of energy, overheating of the dryer, and shutdown of the burner by the airflow (sail) switches, burner hi-limits, or tumbler hi-limit thermostats. The dryer **must be** installed with a proper exhaust duct connection to the outside.

CAUTION: This dryer produces combustible lint and **must be** exhausted to the outdoors.

CAUTION: DRYER **MUST BE** EXHAUSTED TO THE OUTDOORS.

CAUTION: IMPROPERLY SIZED OR INSTALLED EXHAUST DUCTWORK CAN CREATE A POTENTIAL FIRE HAZARD.

NOTE: THE DRYER **MUST BE** INDEPENDENTLY EXHAUSTED. **COMMON DUCTWORK IS NOT ACCEPTABLE.**

The exhaust ductwork **should be** laid out in such a way that the ductwork travels as directly as possible to the outdoors with as few turns as possible. Single or independent dryer venting is recommended.

The shape of the ductwork is not critical so long as the minimum cross section area is provided. It is suggested that the use of 90° turns in ducting be avoided; use 30° and/or 45° angles instead. The radius of the elbow **should preferably be** 1-1/2 times the diameter of the duct.

ALL ductwork **should be** smooth inside with no projections from sheet metal screws or other obstructions, which will collect lint. When adding ducts, the ducts to be added should overlap the duct to which it is connected. **ALL** ductwork joints **must be** taped to prevent moisture and lint from escaping into the building. Additionally, inspection doors **should be** installed at strategic points in the exhaust ductwork for periodic inspection and cleaning of lint from the ductwork.

IMPORTANT: It is recommended that exhaust booster fans not be used in the exhaust ductwork system.

The internal dimensions of the dryer's rectangular exhaust vent ductwork are 8-inches x 20-inches (20.3 cm x 50.8 cm). A transition piece 20-inches (50.8 cm) in diameter round is supplied. The location's exhaust duct **must be** the minimum exhaust size requirement of (20-inches [50.8 cm] round duct or 315 square inches [2,032 square centimeters] square duct) the ductwork from the dryer to the outside exhaust outlet for a horizontal run, with no more than one (1) elbow **must not exceed** 30 feet (9.14 meters) for gas and 20 feet (6.09 meters) for steam dryers. (Refer to the **illustration below** and on **page 19**.) For locations with more than one (1) elbow, the minimum exhaust size for a gas or steam model dryer is 24-inches (60.96 cm) round duct (464 square inches [2,993 square centimeters] duct) **must be** used. The horizontal or vertical duct total run on gas models **must not exceed** 50 feet (15.24 meters) and steam models **must not exceed** 25 feet (7.62 meters) which includes the use of no more than three (3) elbows (refer to the **illustrations** on **page 20** and **page 21**). Should more than the maximum number of elbows be used or if the run exceeds the maximum limits noted, a professional heating, ventilating, and air-conditioning (HVAC) firm **should be** consulted for proper venting information.

IMPORTANT: For extended ductwork runs or where more than the specified number of elbows are used, a professional HVAC firm **should be** contacted for proper venting information.

NOTE: For extended ductwork runs the cross-sectional area of a duct can only be increased to an extent. In some cases the addition of a booster fan in the ductwork may be necessary.

**210 GAS DRYER 5,300 CFM (150.08 CMM)
HORIZONTAL DRYER VENTING**

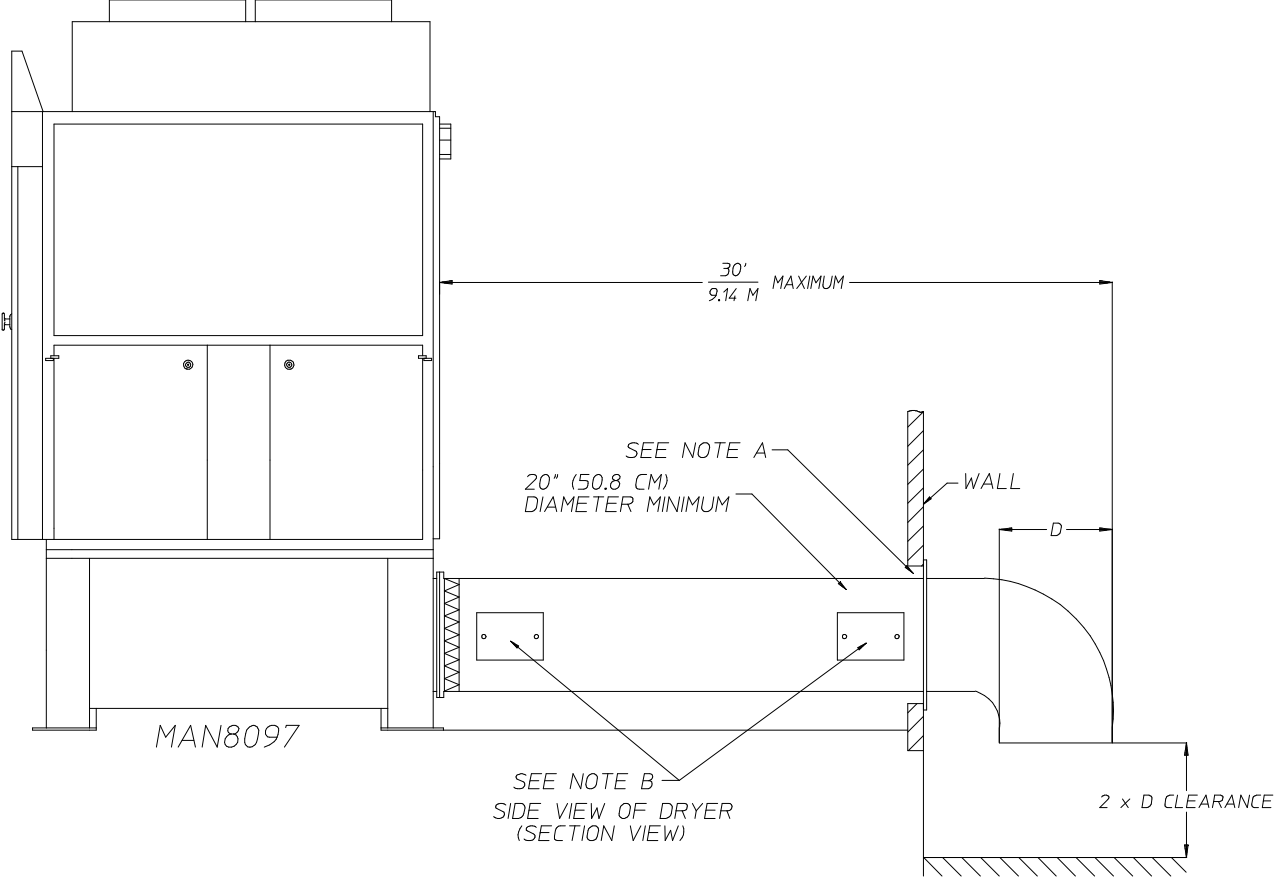

NOTE: "A"- OPENING MUST BE 2-INCHES (5.08 CM) LARGER THAN THE DUCT (ALL THE WAY AROUND). THE DUCT MUST BE CENTERED WITHIN THIS OPENING.
 "B"- INSPECTION DOORS SHOULD BE INSTALLED AT STRATEGIC POINTS FOR PERIODIC INSPECTION AND CLEANING.

210 STEAM DRYER 6,500 CFM (184 CMM)
HORIZONTAL DRYER VENTING

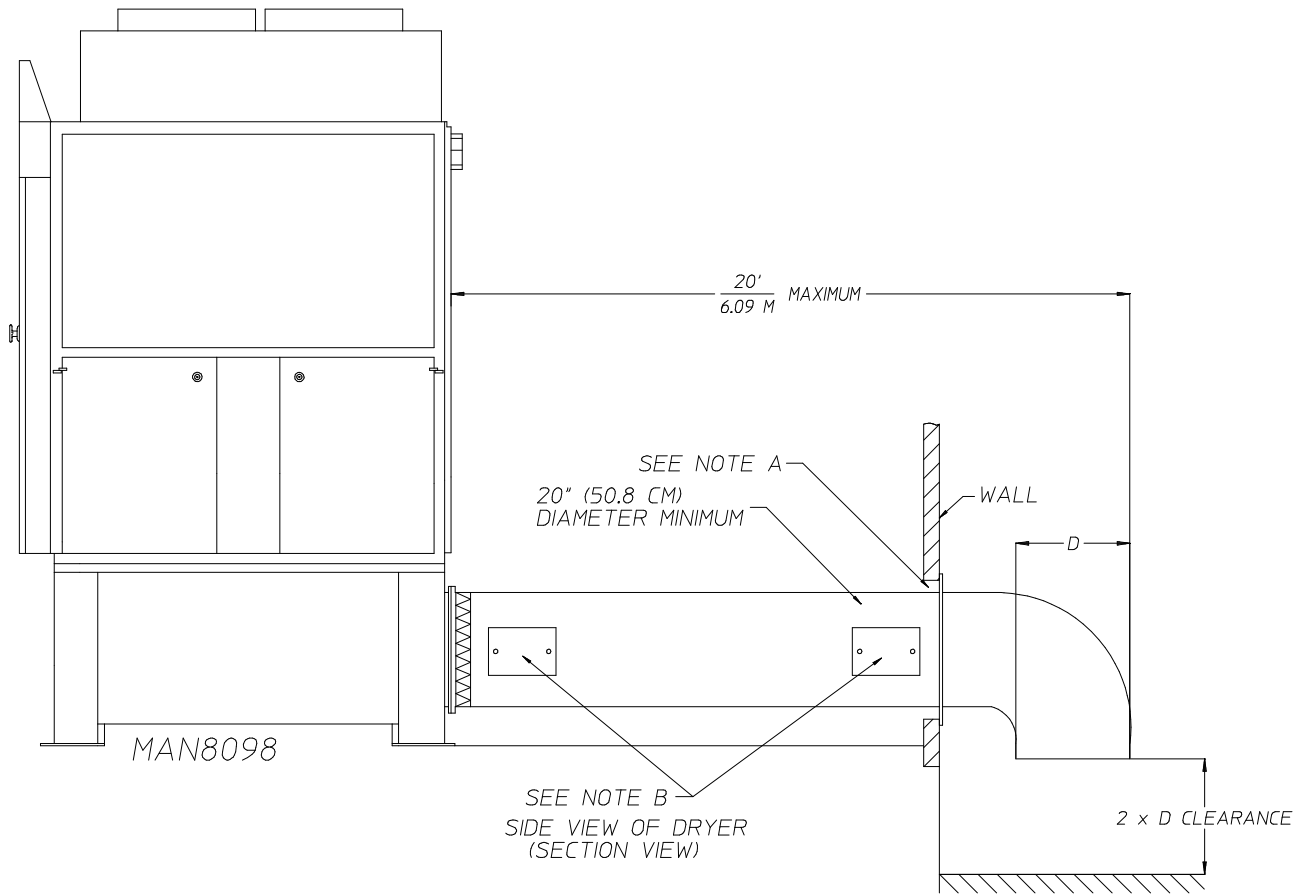

NOTE: "A"- OPENING MUST BE 2-INCHES (5.08 CM) LARGER THAN THE DUCT (ALL THE WAY AROUND).
THE DUCT MUST BE CENTERED WITHIN THIS OPENING.
"B"- INSPECTION DOORS SHOULD BE INSTALLED AT STRATEGIC POINTS
FOR PERIODIC INSPECTION AND CLEANING.

**210 GAS DRYER 5,300 CFM (150.08 CMM)
VERTICAL DRYER VENTING**

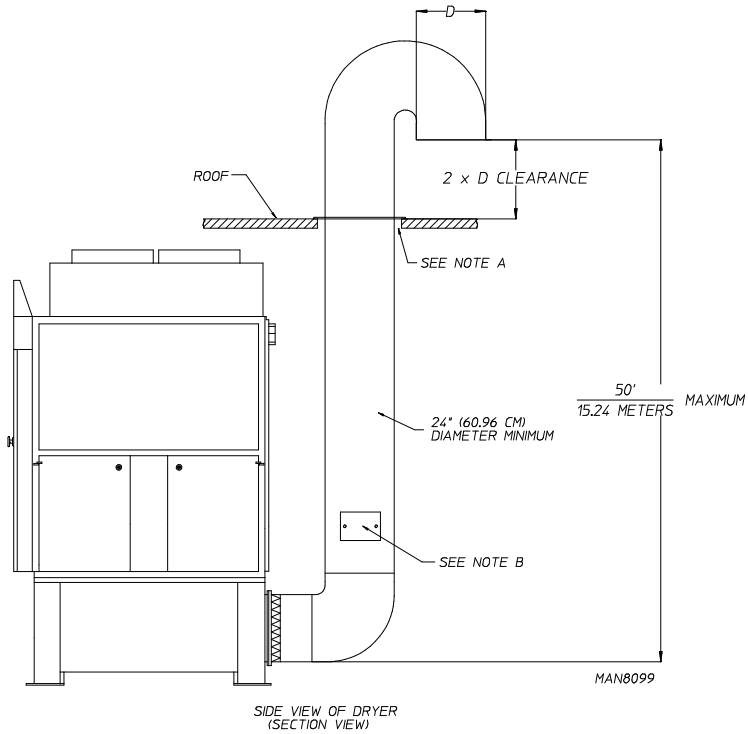

NOTE: *A*- OPENING MUST BE 2-INCHES (5.08 CM) LARGER THAN THE DUCT (ALL THE WAY AROUND).
THE DUCT MUST BE CENTERED WITHIN THIS OPENING.
B- INSPECTION DOORS SHOULD BE INSTALLED AT STRATEGIC POINTS
FOR PERIODIC INSPECTION AND CLEANING.

**210 STEAM DRYER 6,500 CFM (184 CMM)
VERTICAL DRYER VENTING**

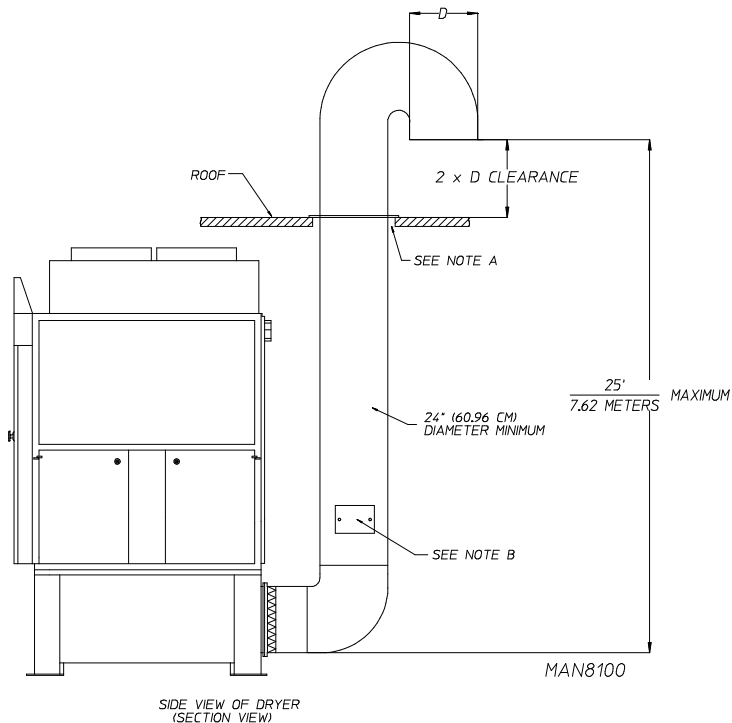

NOTE: *A*- OPENING MUST BE 2-INCHES (5.08 CM) LARGER THAN THE DUCT (ALL THE WAY AROUND).
THE DUCT MUST BE CENTERED WITHIN THIS OPENING.
B- INSPECTION DOORS SHOULD BE INSTALLED AT STRATEGIC POINTS
FOR PERIODIC INSPECTION AND CLEANING.

**210 GAS DRYER 5,300 CFM (150.08 CMM)
VERTICAL / HORIZONTAL DRYER VENTING**

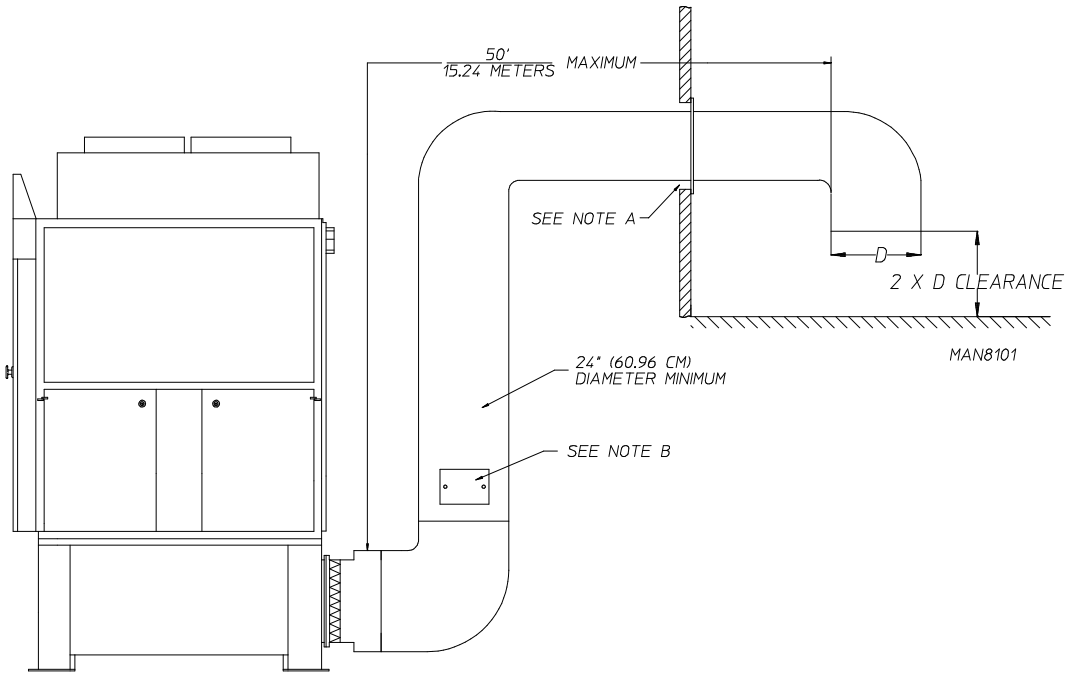

SIDE VIEW OF DRYER
(SECTION VIEW)

NOTE: *A*- OPENING MUST BE 2-INCHES (5.08 CM) LARGER THAN THE DUCT (ALL THE WAY AROUND).
THE DUCT MUST BE CENTERED WITHIN THIS OPENING.
B- INSPECTION DOORS SHOULD BE INSTALLED AT STRATEGIC POINTS FOR PERIODIC INSPECTION AND CLEANING

**210 STEAM DRYER 6,500 CFM (184 CMM)
VERTICAL / HORIZONTAL DRYER VENTING**

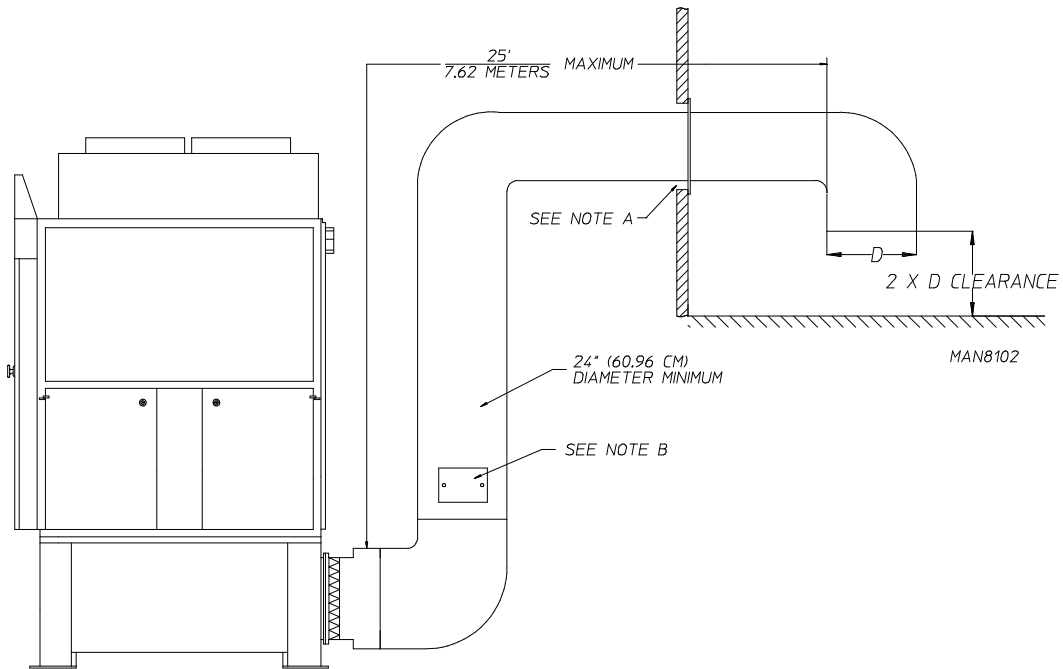

SIDE VIEW OF DRYER
(SECTION VIEW)

NOTE: *A*- OPENING MUST BE 2-INCHES (5.08 CM) LARGER THAN THE DUCT (ALL THE WAY AROUND).
THE DUCT MUST BE CENTERED WITHIN THIS OPENING.
B- INSPECTION DOORS SHOULD BE INSTALLED AT STRATEGIC POINTS FOR PERIODIC INSPECTION AND CLEANING

a. Outside Ductwork Protection

- 1) To protect the outside end of the horizontal ductwork from the weather, a 90° elbow bent downward **should be** installed where the exhaust exits the building. If the exhaust ductwork travels vertically up through the roof, it **should be** protected from the weather by using a 180° turn to point the opening downward. In either case, allow at least twice the diameter of the duct between the duct opening and nearest obstruction.

IMPORTANT: DO NOT use screens, louvers, or caps on the outside opening of the exhaust ductwork.

NOTE: Exhaust back pressure measured by a manometer at the dryer exhaust duct area **must be** no less than 0 and **must not exceed** 0.3 inches (0.74 mb) of water column (W.C.).

NOTE: When the exhaust ductwork passes through a wall, ceiling, or roof made of combustible materials, the opening **must be** 2-inches (5.08 cm) larger than the duct (all the way around). The duct **must be** centered within this opening.

VERTICAL DUCTING

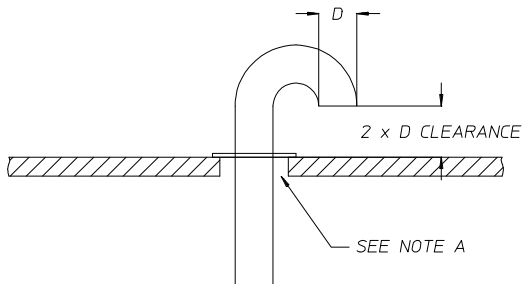

HORIZONTAL DUCTING

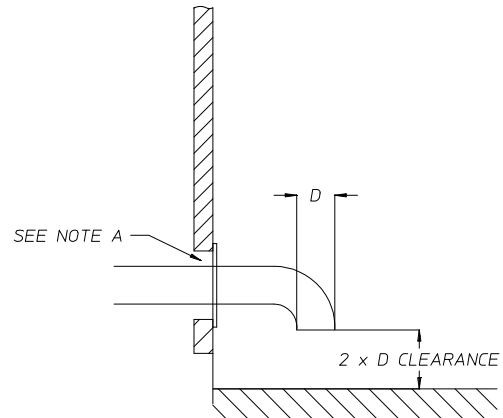

NOTE "A": OPENING MUST BE TWO (2) INCHES (5.08 CM) LARGER THAN DUCT (ALL THE WAY AROUND). THE DUCT MUST BE CENTERED WITHIN THIS OPENING.

MAN4706

E. COMPRESSED AIR SUPPLY SYSTEM

A clean, dry, and regulated air supply of 80 PSI (5.51 bar) compressed air **must be** supplied to the dryer. The connection size is 1/8" N.P.T. No air filtering or pressure regulating devices are provided with the standard non-tilt dryer.

1. Compressed Air Supply Connection Location For Non-Tilt Dryers

a. Gas Dryers

The air line supply connection is made into the 1/8" N.P.T. port on the air jet solenoid valve which is located in the base of the dryer. (Refer to the **illustration below.**)

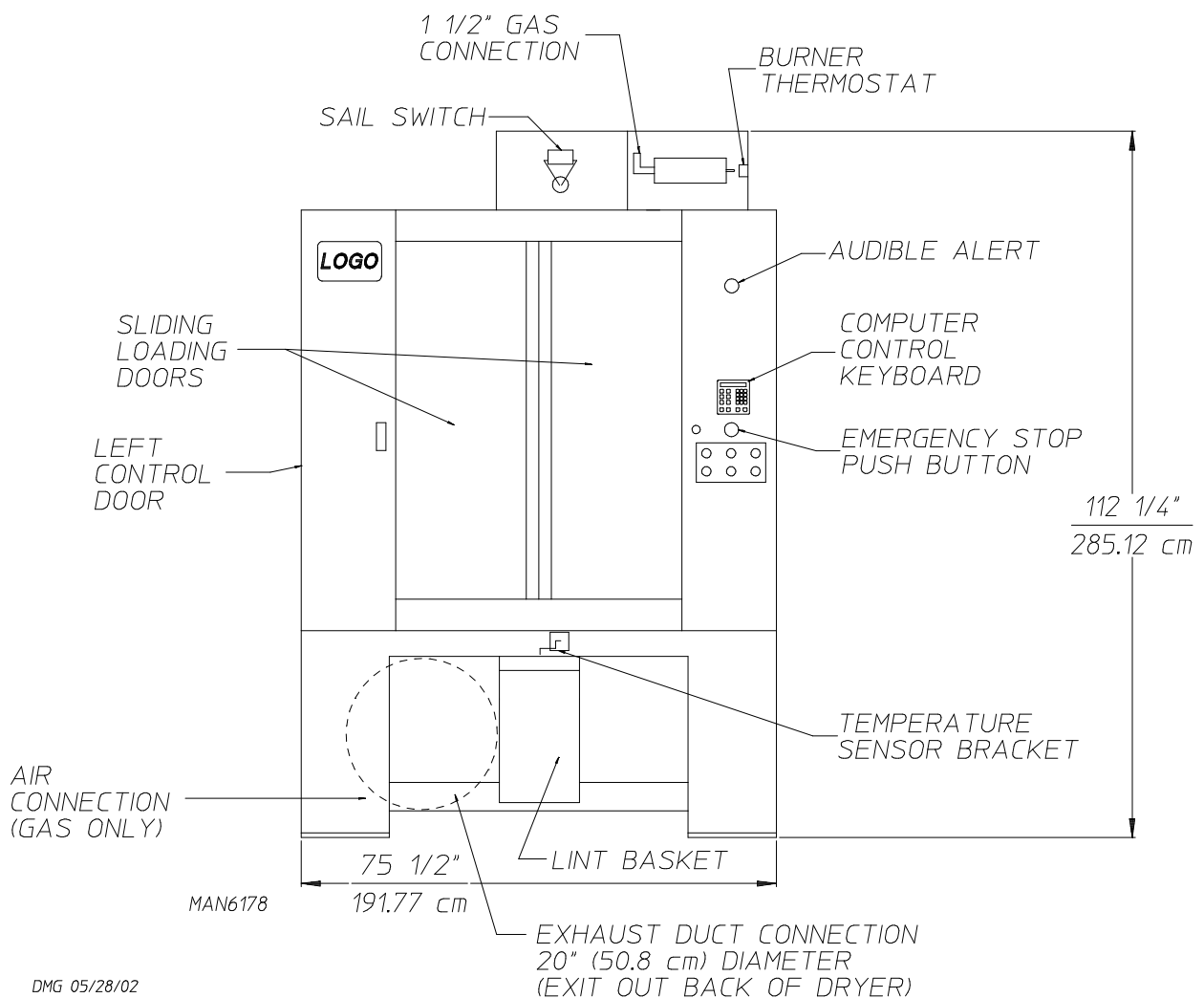

DMG 05/28/02

b. Steam Dryers

The air line supply connection is made into the 1/8" N.P.T. tee, which is located at the left hand side of the top of the dryer. (Refer to the **illustration below.**)

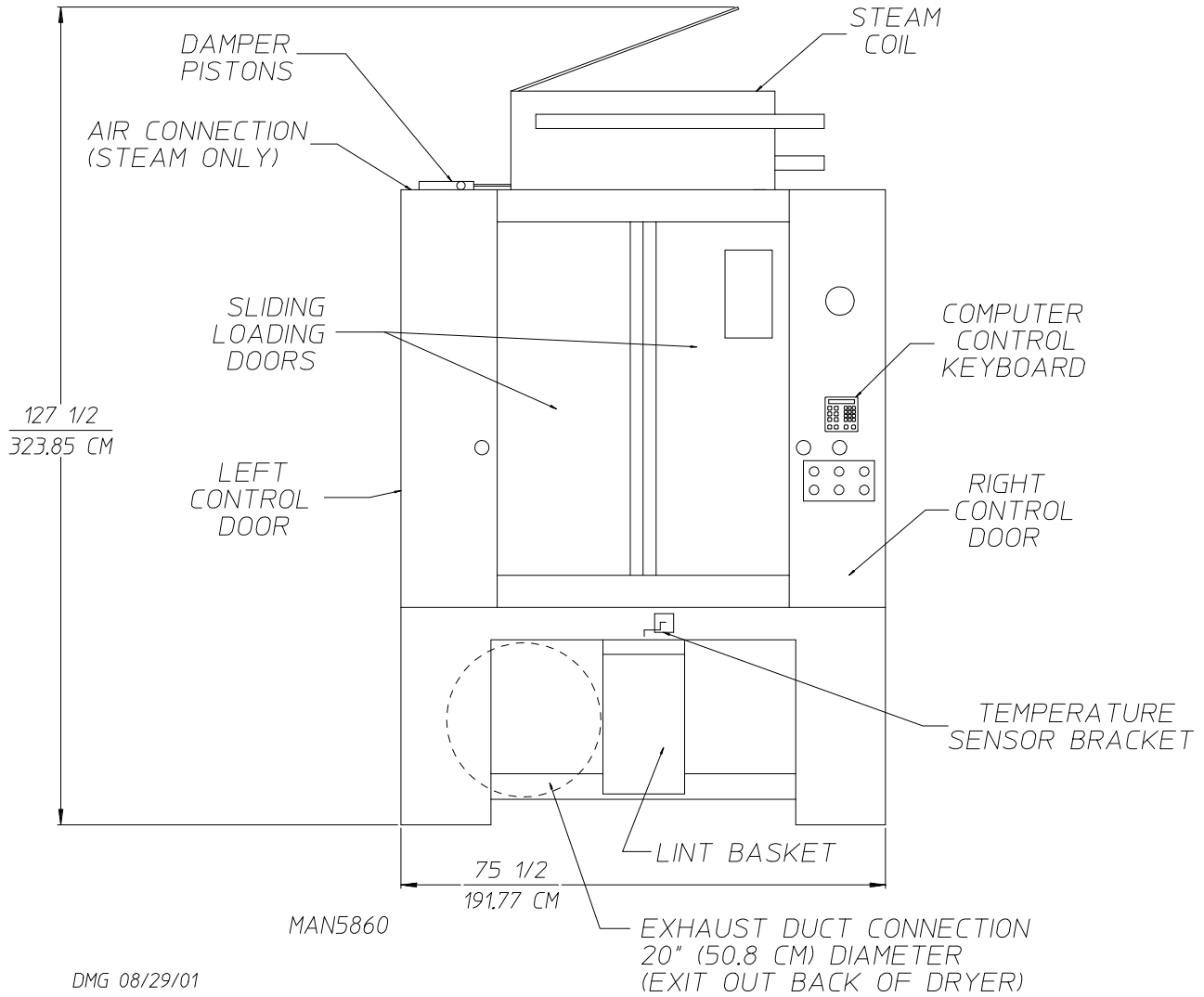

F. ELECTRICAL INFORMATION

1. Electrical Requirements

It is your responsibility to have **ALL** electrical connections made by a properly licensed and competent electrician to assure that the electrical installation is adequate and conforms to local and state regulations or codes. In the absence of such codes, **ALL** electrical connections, materials, and workmanship **must conform** to the applicable requirements of the National Electrical Code ANSI/NFPA NO. 70-LATEST EDITION or in Canada, the Canadian Electrical Codes Parts 1 & 2 CSA C22.1-1990 or LATEST EDITION.

IMPORTANT: Failure to comply with these codes or ordinances, and/or the requirements stipulated in this manual can result in personal injury or component failure.

NOTE: Component failure due to improper installation VOIDS THE WARRANTY.

Each dryer **should be** connected to an independently protected branch circuit. The dryer **must be** connected with copper wire only. **DO NOT use aluminum wire, which could cause a fire hazard.** The copper conductor wire/cable **must be** of proper ampacity and insulation in accordance with electric codes for making **ALL** service connections.

NOTE: The use of aluminum wire will VOID THE WARRANTY.

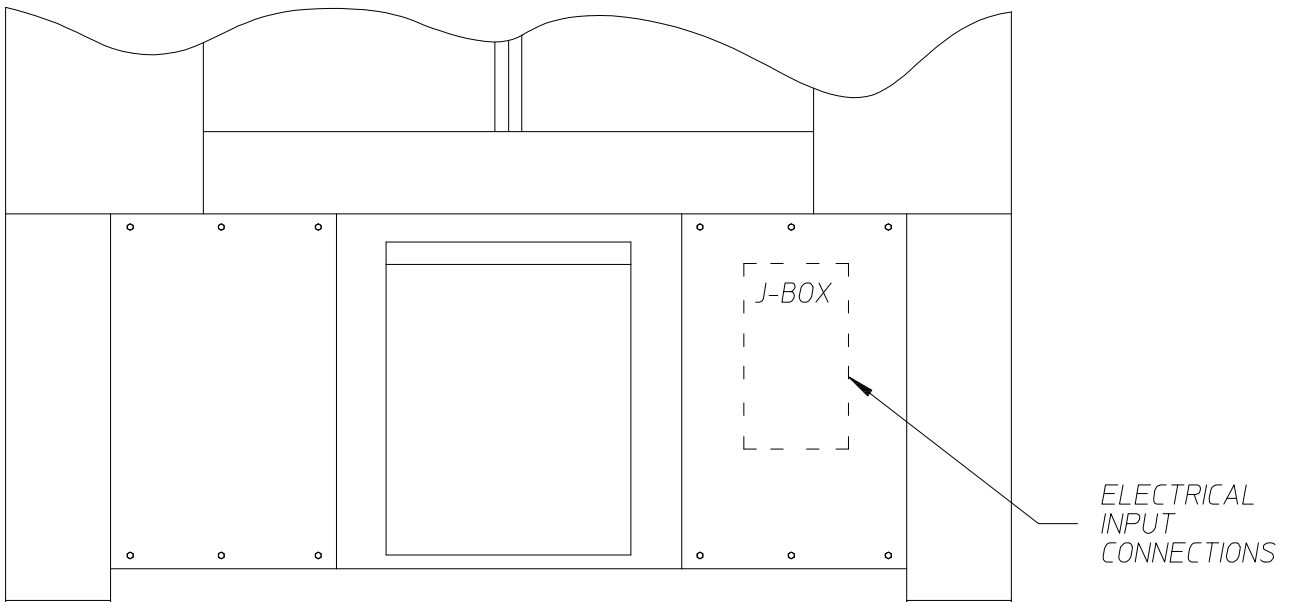

DMG 02/05/01

FRONT VIEW OF
NON-TILT BASE

MAN5637

2. Electrical Service Specifications

AD-210 NON-TILT (GAS – REAR EXHAUST) 7.5 hp Blower Motor / 3 hp Drive Motor					
ELECTRICAL SERVICE SPECIFICATIONS (PER DRYER)					
IMPORTANT: 208 VAC AND 230/240 VAC ARE NOT THE SAME. When ordering, specify exact voltage.					
NOTES: A. When fuses are used they must be dual element, time delay, current limiting, class RK1 or RK5 ONLY. Calculate/determine correct fuse value, by applying either local and/or National Electrical Codes to listed appliance amp draw data.					
B. Circuit breakers are thermal-magnetic (industrial) motor curve type ONLY. For others, calculate/verify correct breaker size according to appliance amp draw rating and type of breaker used.					
C. Circuit breakers for 3-phase (3 ϕ) dryers must be 3-pole type.					
SERVICE VOLTAGE	PHASE	WIRE SERVICE	APPROX. AMP DRAW		CIRCUIT BREAKER
			60 Hz	50 Hz	
208	3 ϕ	3/4	36.2	—	60
220	3 ϕ	3	35.2	—	60
240	3 ϕ	3	34.2	—	60
230	3 ϕ	3	—	35.1	60
380	3 ϕ	3/4	—	20.2	30
400	3 ϕ	3/4	—	20.0	30
416	3 ϕ	3/4	—	19.9	30
460	3 ϕ	3	18.1	—	30
480	3 ϕ	3	18.1	—	30
575	3 ϕ	3	14.9	—	20

8/19/14

IMPORTANT: The dryer *must be* connected to the electric supply shown on the data label that is affixed to the right electrical control panel.

WARNING: **208 VAC AND 240 VAC ARE NOT THE SAME.** Any damage done to dryer components due to improper voltage connections will automatically VOID THE WARRANTY.

NOTE: ADC reserves the right to make any changes in specifications at any time without notice or obligation.

**AD-210 NON-TILT (STEAM / GAS – SIDE EXHAUST)
15 hp Blower Motor / 3 hp Drive Motor**

ELECTRICAL SERVICE SPECIFICATIONS (PER DRYER)

IMPORTANT: 208 VAC AND 230/240 VAC ARE NOT THE SAME. When ordering, specify exact voltage.

- NOTES:**
- A. When fuses are used they must be dual element, time delay, current limiting, class RK1 or RK5 ONLY. Calculate/determine correct fuse value, by applying either local and/or National Electrical Codes to listed appliance amp draw data.
 - B. Circuit breakers are thermal-magnetic (industrial) motor curve type ONLY. For others, calculate/verify correct breaker size according to appliance amp draw rating and type of breaker used.
 - C. Circuit breakers for 3-phase (3Ø) dryers must be 3-pole type.

SERVICE VOLTAGE	PHASE	WIRE SERVICE	APPROX. AMP DRAW		CIRCUIT BREAKER
			60 Hz	50 Hz	
208	3Ø	3/4	55.2	—	90
240	3Ø	3	51.0	—	80
230	3Ø	3	—	53.5	80
380	3Ø	3/4	—	31.1	50
400	3Ø	3/4	—	29.9	50
416	3Ø	3/4	—	29.2	50
460	3Ø	3	26.6	—	45
480	3Ø	3	26.6	—	45
575	3Ø	3	22.3	—	40

8/19/14

IMPORTANT: The dryer *must be* connected to the electric supply shown on the data label that is affixed to the right electrical control panel.

WARNING: 208 VAC AND 240 VAC ARE NOT THE SAME. Any damage done to dryer components due to improper voltage connections will automatically VOID THE WARRANTY.

NOTE: ADC reserves the right to make any changes in specifications at any time without notice or obligation.

3. Electrical Connections

NOTE: A wiring diagram is included with each dryer and is located in the blueprint pocket inside the left side control cabinet.

The main electrical input connections to the dryer are the 3-phase (3 ϕ) power leads (L1, L2, and L3), GROUND, and in the case of 4 wire service, the NEUTRAL. These electrical connections are made at the power distribution block located in the base front electrical enclosure.

The main electrical (3-phase [3 ϕ]) connections (L1, L2, and L3) and the optional (single-phase [1]) connection **must be** provided and installed in accordance with state and local codes. In the absence of these codes, grounding **must conform** to applicable requirements of the National Electrical Code ANSI/NFPA NO. 70-LATEST EDITION. In **ALL** cases, a strain relief **must be** used where the wire(s) enter the dryer electrical service (relay) box.

NOTE: A CIRCUIT SERVICING EACH DRYER *MUST BE* PROVIDED.

4. Main Grounding

A ground (earth) connection **must be** provided and installed in accordance with state and local codes. In the absence of these codes, grounding **must conform** to applicable requirements of the National Electrical Code ANSI/NFPA NO. 70-LATEST EDITION, or in Canada, the installation **must conform** to applicable Canada Standards: Canadian Electrical Codes Parts 1 & 2 CSA C22.1-1990 or LATEST EDITION. The ground connection may be to a proven earth ground at the location service panel.

NOTE: A grounding connection (terminal lug) is provided in the dryer in the Base Electrical Junction Box.

For added personal safety, when possible, it is suggested that a separate ground wire (sized per local codes) be connected from the ground connection of the dryer to a cold water pipe. ***DO NOT ground to a gas or hot water pipe.*** The grounded cold water pipe must have metal to metal connections **ALL** the way to electrical ground. If there are any nonmetallic interruptions, such as a meter, pump, plastic, rubber, or other insulating connectors, they **must be** jumped out with no. 4 copper wire and securely clamped to bare metal at both ends.

IMPORTANT: For personal safety and proper operation, the dryer ***must be*** grounded. For proper operation of the microprocessor controller (computer), an earth (zero) ground is required.

NOTE: Grounding via metallic electrical conduit (pipe) **is not recommended.**

G. GAS INFORMATION

It is your responsibility to have **ALL** plumbing connections made by a qualified professional to assure that the gas plumbing installation is adequate and conforms to local and state regulations or codes. In the absence of such codes, **ALL** plumbing connections, materials, and workmanship **must conform** to the applicable requirements of the National Fuel Gas Code ANSI Z223.1-LATEST EDITION, or in Canada, the Canadian Installation Codes CAN/CGA-B149.1-M91 (Natural Gas) or CAN/CGA-B149.2-M91 (Liquid Propane Gas) or LATEST EDITION.

In Australia, the fuel gas code is AS 5601/AG 601, local authority, gas, electricity, and any other relevant statutory regulations.

IMPORTANT: Failure to comply with these codes or ordinances, and/or the requirements stipulated in this manual, can result in personal injury and improper operation of the dryer.

The dryer and its individual shutoff valves **must be** disconnected from the gas supply piping system during any pressure testing of that system at test pressures in excess of 1/2 psig (3.5 kPa). The dryer **must be** isolated from the gas supply piping system by closing its individual manual shutoff valve during any pressure test of the gas supply system at test pressures equal to or less than 1/2 psig (3.5 kPa).

IMPORTANT: Failure to isolate or disconnect dryer from supply as noted can cause irreparable damage to the gas valve VOIDING THE WARRANTY.

WARNING: FIRE OR EXPLOSION COULD RESULT.

1. Gas Supply

The gas dryer installation must meet the American National Standard...National Fuel Gas Code ANSI Z223.1-LATEST EDITION, or in Canada, the Canadian Installation Codes CAN/CGA-B149.1 M91 (Natural Gas) or CAN/CGA-B149.2-M91 (Liquid Propane Gas) or LATEST EDITION, as well as local codes and ordinances and **must be** done by a qualified professional.

NOTE: Undersized gas piping will result in ignition problems, slow drying, increased use of energy, and can create a safety hazard.

The dryer **must be** connected to the type of heat/gas indicated on the dryer data label that is affixed to the right electrical control panel. If this information does not agree with the type of gas available, **DO NOT operate the dryer**. Contact the reseller who sold the dryer or contact the **ADC** factory.

IMPORTANT: Any burner changes or conversions **must be** made by a qualified professional.

The input ratings shown on the dryer data label are for elevations up to 2,000 feet (610 meters), unless elevation requirements over 2,000 feet (610 meters) were specified at the time the dryer order was placed with the factory. The adjustment or conversion of the dryers in the field for elevations over 2,000 feet (610 meters) is made by changing each burner orifice. If this conversion is necessary, contact the reseller who sold the dryer or contact the **ADC** factory.

IMPORTANT: THIS GAS DRYER **IS NOT** PROVIDED WITH AN INTERNAL GAS SUPPLY SHUTOFF AND AN EXTERNAL GAS SUPPLY SHUTOFF **MUST BE** PROVIDED.

2. Technical Gas Data

a. Gas Specifications

TYPE OF GAS					
	NATURAL			LIQUID PROPANE	
Manifold Pressure*	3.5 inches W.C.	8.7 mb	10.5 inches W.C.	26.1 mb	
In-Line Pressure	6.0 - 12.0 inches W.C.	14.92 - 29.9 mb	11.0 inches W.C.	27.4 mb	

Shaded areas are stated in metric equivalents

* Measured at outlet side of gas valve pressure tap when gas valve is on.

b. Gas Connections

Run a 1-1/2" pipe from the main gas header to the dryer. There is a 1-1/4" gas pipe connection at the top of the dryer. The dryer has a gas burner box with a 1-1/4" gas connection.

Inlet connection ----- 1-1/4" N.P.T.
 Inlet Supply Size ----- 1-1/2" N.P.T. (minimum)
 Btu/hr input (per dryer) --- 650,000 (163,800 kcal/hr)

1) Natural Gas

Pressure regulation is controlled by the gas valve's internal pressure regulator. Incoming supply pressure **must be** consistently between a minimum of 6.0 inches (14.92 mb) water column and a maximum of 12.0 inches (29.9 mb) water column.

2) Liquid Propane Gas

Pressure regulation is controlled by the gas valve's internal pressure regulator, which is blocked open so that the gas pressure **must be** regulated upstream of the dryer. The pressure measured at the gas valve pressure tap **must be** a consistent 10.5 inches (26.1 mb) water column. There is no regulator or regulation provided in a liquid propane gas dryer. The water column **must be** regulated at the source (liquid propane tank) or external regulator/regulation **must be** added to each dryer.

		TYPE OF GAS						Liquid Propane Conversion Kit Part Number
Btu/hr Rating	kcal/hr Rating	Natural			Liquid Propane			
		Qty.	D.M.S.*	Part No.	Qty.	D.M.S.*	Part No.	
650,000	163,800	5	#1	140840	5	#29	140820	883790

Shaded area is stated in metric equivalent

* Drill Measurement Size (D.M.S.) equivalents are as follows:

Natural Gas #1 = 0.2280" (5.7912 mm).
 Liquid Propane Gas #29 = 0.1360" (3.4544 mm).

3. Piping Connections

ALL components/materials **must conform** to National Fuel Gas Code Specifications ANSI Z223.1-LATEST EDITION, or in Canada, CAN/CGA-B149.1-M91 (Natural Gas) or CAN/CGA-B149.2-M91 (Liquid Propane Gas) or LATEST EDITION (for General Installation and Gas Plumbing), as well as local codes and ordinances and **must be** done by a qualified professional. It is important that gas pressure regulators meet applicable pressure requirements, and that gas meters be rated for the total amount of **ALL** the appliance BTUs being supplied.

The dryer is provided with a 1-1/4" N.P.T. inlet pipe connections extending out of the top of the burner box. The minimum pipe size (supply line) to the dryer is 1-1/2" N.P.T. For ease of servicing, the gas supply line to each dryer must have its own shutoff valve.

The size of the main gas supply line (header) will vary depending on the distance this line travels from the gas meter or, in the case of liquid propane gas, the supply tank, other gas-operated appliances on the same supply line, etc. Specific information regarding supply line size **should be** determined by the gas supplier.

NOTE: Undersized gas supply piping can create a low or inconsistent pressure, which will result in erratic operation of the burner ignition system.

TYPICAL NATURAL GAS INSTALLATION

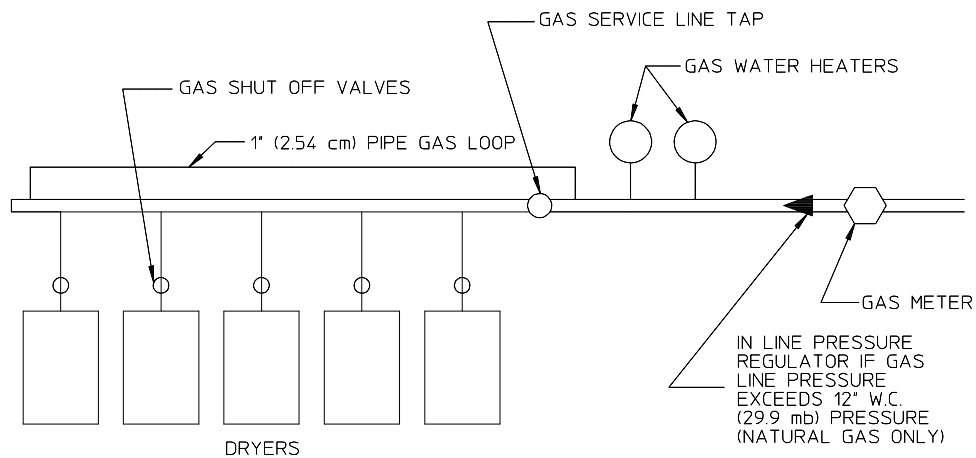

TYPICAL L.P. GAS INSTALLATION

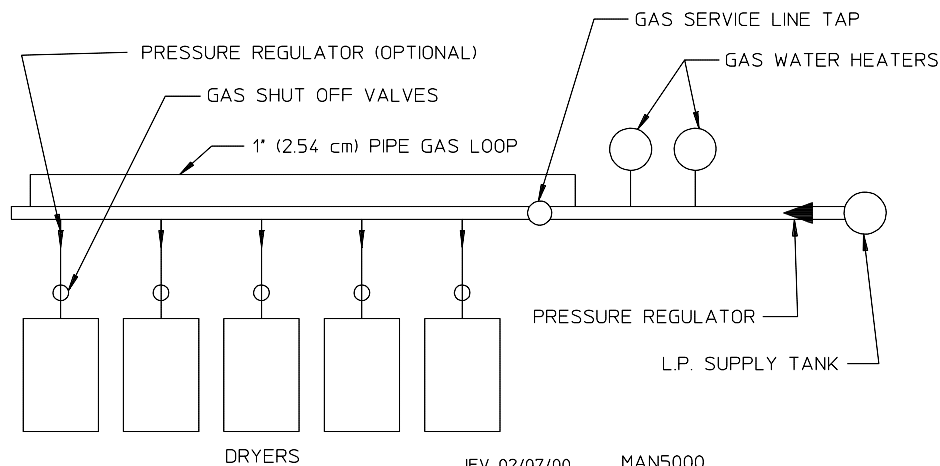

JEV 02/07/00 MAN5000

Consistent gas pressure is essential at **ALL** gas connections. It is recommended that a 1-inch (2.54 cm) pipe gas loop be installed in the supply line servicing a bank of dryers. An in-line pressure regulator **must be** installed in the gas supply line (header) if the (natural) gas pressure exceeds 12.0 inches (29.9 mb) of water column pressure.

IMPORTANT: A water column pressure of 3.5 inches (8.7 mb) for natural gas and 10.5 inches (26.1 mb) for liquid propane dryers is required at the gas valve pressure tap of each dryer for proper and safe operation.

A 1/8" N.P.T. plugged tap, accessible for a test gauge connection, **must be** installed in the main gas supply line immediately upstream of each dryer.

IMPORTANT: Pipe joint compounds that resist the action of natural and liquid propane gases **must be** used.

IMPORTANT: Test **ALL** connections for leaks by brushing on a soapy water solution (liquid detergent works well).

WARNING: NEVER TEST FOR LEAKS WITH A FLAME!!!

ALL components/materials **must conform** to National Fuel Gas Code Specifications ANSI Z223.1-LATEST EDITION, or in Canada, CAN/CGA-B149.1-M91 (Natural Gas) or CAN/CGA-B149.2-M91 (Liquid Propane Gas) or LATEST EDITION (for General Installation and Gas Plumbing), as well as local codes and ordinances and **must be** done by a qualified professional. It is important that gas pressure regulators meet applicable pressure requirements, and that gas meters be rated for the total amount of **ALL** the appliance BTUs being supplied.

IMPORTANT: The dryer and its individual shutoff valve **must be** disconnected from the gas supply piping system during any pressure testing of that system at test pressures in excess of 1/2 psig (3.5 kPa).

NOTE: The dryer **must be** isolated from the gas supply piping system by closing its individual manual shutoff valve during any pressure testing of the gas supply piping system at test pressures equal to or less than 1/2 psig (3.5 kPa).

H. WATER SUPPLY CONNECTION FOR SENSOR ACTIVATED FIRE EXTINGUISHING (S.A.F.E.) SYSTEM

The dryer comes with S.A.F.E. system, connect a 40 ± 20 psig (2.75 ± 1.37 bar) 1/2" diameter water line to supply the water valve of the S.A.F.E. system with the required water supply. The water connection is located on top of the dryer on the left hand side. A tap has been supplied for the customer to connect a manual bypass to the S.A.F.E. system. The same water connection apply to the manual bypass tap as specified above.

I. STEAM INFORMATION

It is your responsibility to have **ALL** steam plumbing connections made by a qualified professional to assure that the installation is adequate and conforms to local and state regulations or codes.

IMPORTANT: Failure to comply with the requirements stipulated in this manual can result in component failure which will VOID THE WARRANTY.

NOTE: The dryer is manufactured with a pneumatic (piston) damper system which requires an external supply of clean, dry, and regulated air 80 PSI +/- 10 PSI (5.51 bar +/- 0.68 bar).

1. Steam Coil pH Level

The normal pH level for copper type steam coils **must be** maintained between a value of 8.5 to 9.5. For steel type steam coils the pH level **must be** maintained between a value of 9.5 to 10.5. These limits are set to limit the acid attack of the steam coils.

IMPORTANT: Coil failure due to improper pH level will VOID THE WARRANTY.

2. Steam Requirements - High Pressure

Inlet-----2" supply line connection

Return-----2" return line connection

Operating Steam Pressure		
Maximum	125 psig*	862 kPa
Heat Input (Normal Load)	27 Bhp	
Consumption (Approximate)	890 lb/hr	404.5 kg/hr

Shaded areas are stated in metric equivalents

* The minimum operating pressure for optimum results is 100 psig (689.47 kPa).

3. Installation Instructions

To ensure that an adequate supply of steam is provided, be sure that the steam supply lines and steam return lines are sized and laid out as stipulated in this manual. Inadequate steam supply lines and steam return lines or improper steam plumbing will result in poor performance and can cause component failure. Clean, dry, and regulated steam **must be** provided to the dryer.

IMPORTANT: Steam coil failure due to water hammer by wet steam will VOID THE WARRANTY.

- a. The presence of the condensate in the steam supply line will cause water hammer and subsequent heat exchanger (steam coil) failure. The steam supply connection into the main supply line **must be** made within a minimum 10-inch (25.4 cm) riser. This will prevent any condensate from draining towards the dryer.
- b. The steam supply line to the dryer must include a 12-inch (30.48 cm) riser along with a drip trap and check valve. This will prevent any condensate from entering the steam coil.
- c. Flexible hoses or couplings **must be** used. The dryer vibrates slightly when it runs and this will cause the steam coil connections to crack if they are hard piped to the supply and return mains.
- d. Shutoff valves for each dryer **should be** installed in the supply, return, and drip trap return lines. This will allow the dryer to be isolated from the supply and return mains if the dryer needs maintenance work.
- e. Install an inverted bucket steam trap and check valve for each unit at least 12-inches (30.48 cm) below steam coil as close to the coil as possible.
- f. The supply and return lines **should be** insulated. This will save energy and provide for safety of the operator and maintenance personnel.
- g. Water pockets in the supply line, caused by low points, will provide wet steam to the coil possibly causing coil damage. **ALL** horizontal runs of steam supply piping **should be** pitched 1/4-inch (6.35 mm) for every 1 foot (0.31 meters) back towards the steam supply header causing any condensate in the line to drain to the header. Install a bypass trap in any low point to eliminate wet steam.

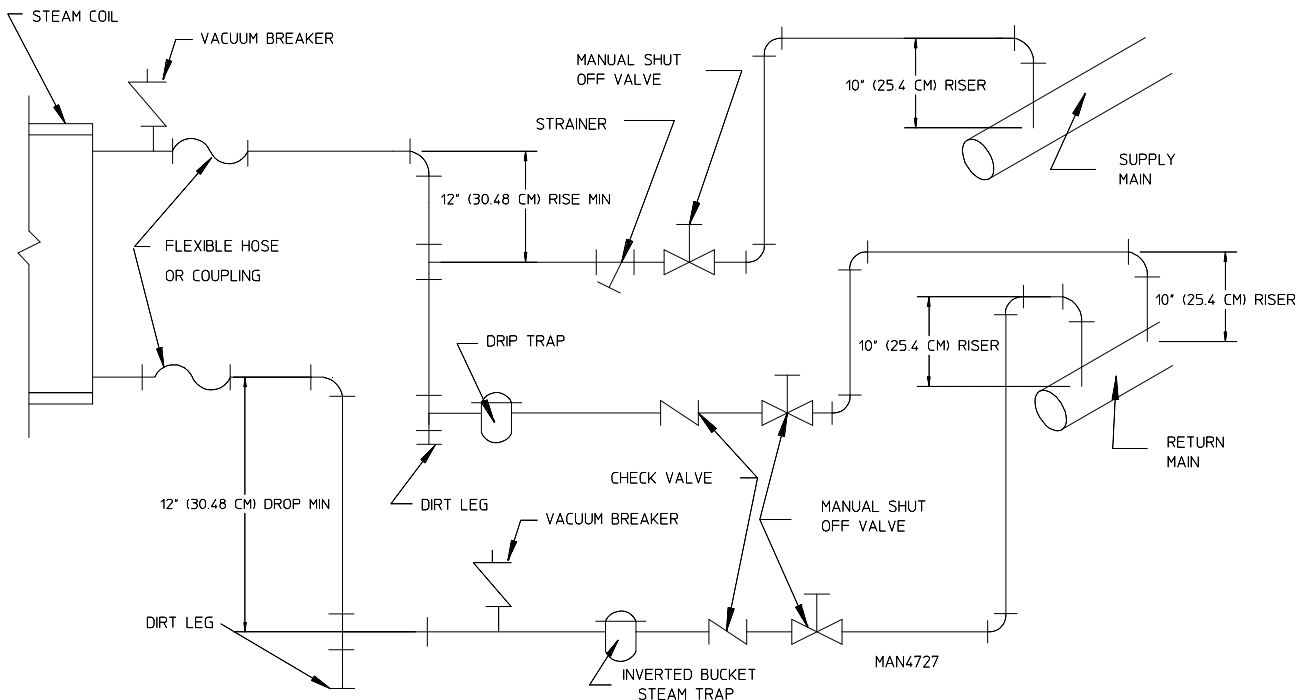

4. Steam Damper Air System Connections

The dryer is manufactured with a pneumatic (piston) damper system, which requires an external supply of compressed air. The air connection is made at the left hand side on top of the dryer.

a. Air Requirements

Compressed Air Supply	Air Pressure	
Normal	80 PSI	5.51 bar
Minimum Supply	70 PSI	4.82 bar
Maximum Supply	90 PSI	6.20 bar

Shaded areas are stated in metric equivalents

b. Air Connection

Air connection to system---1/8" F.P.T.

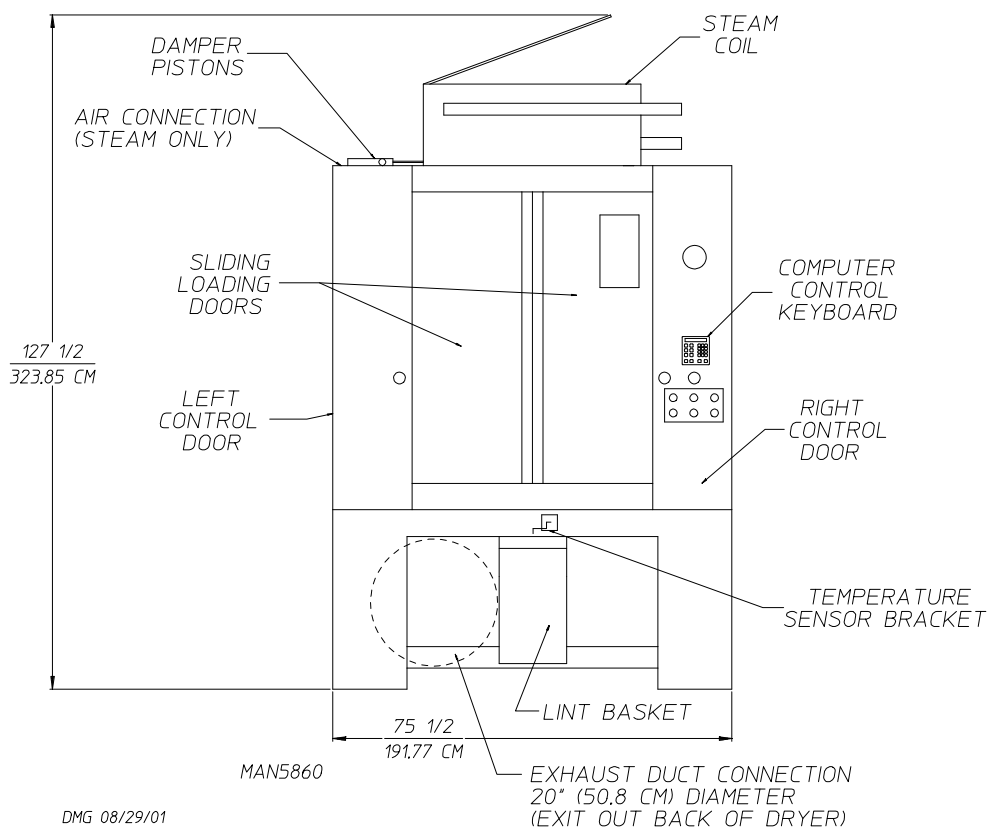

- c. No air regulation is provided with a standard dryer. External regulation/filtration of 80 PSI (5.51 bar) **must be** provided. It is suggested that a filter/regulator/gauge (F/R/G) arrangement be added to the compressed air line just before the dryer connection. This is necessary to insure that correct and clean air pressure is achieved. The F/R/G is provided on dryers with the optional automatic door or the optional sprinkler circuit.

5. Steam Damper System Operation

The steam damper, as shown in the **illustration below**, allows the coil to stay constantly charged eliminating repeated expansion and contraction. When the damper is opened, the air immediately passes through the already hot coil, providing instant heat to start the drying process. When the damper is closed, ambient air is drawn directly into the tumbler, allowing a rapid cool down.

Diagram 1 – shows the damper in the heating (open) mode, allowing heat into the tumbler.

Diagram 2 – shows the damper in the cool down (closed) mode, pulling ambient air directly into the tumbler without passing through the coils.

NOTE: With the dryer off or with no air supply, the damper is in the cool down mode as shown in Diagram 2.

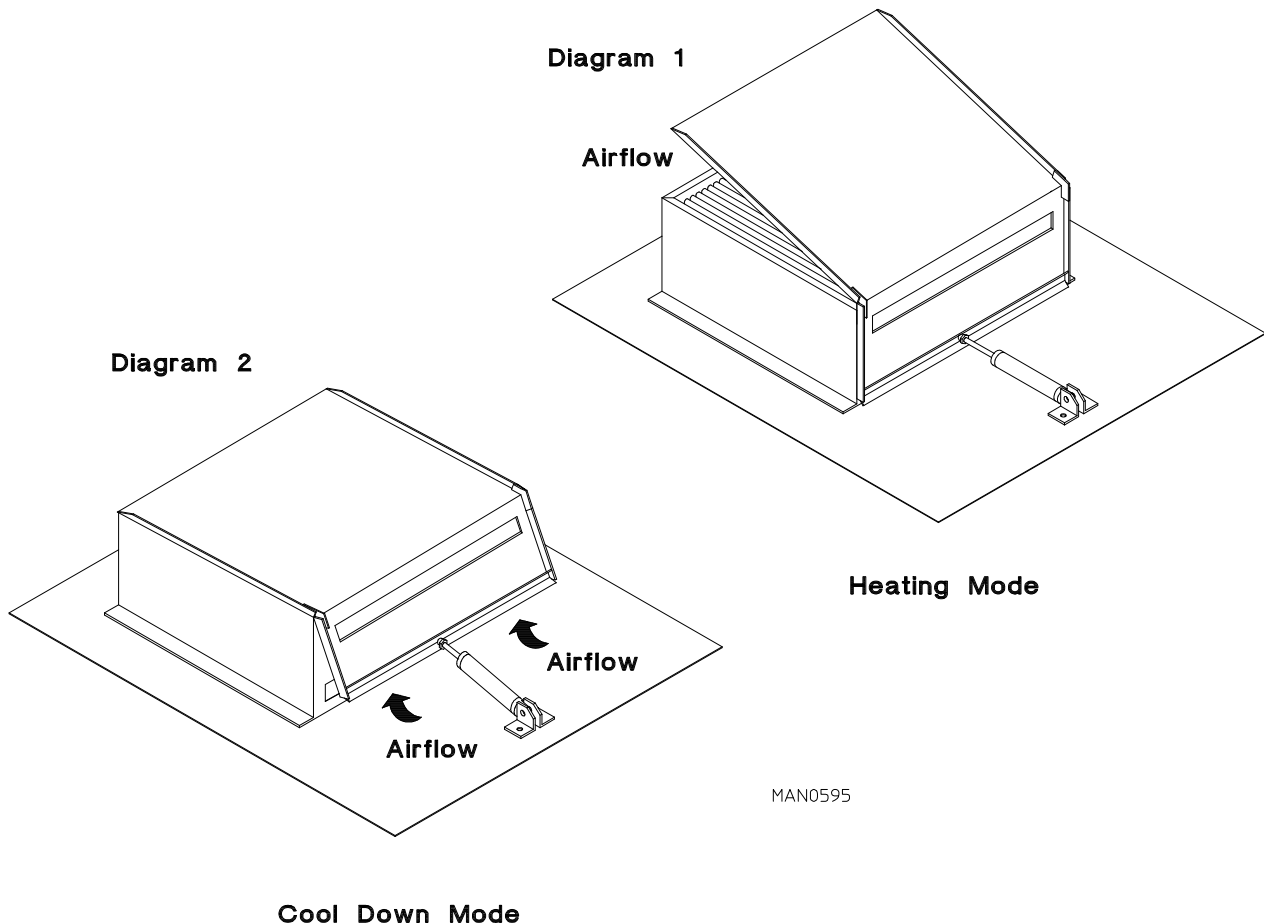

6. Steam Damper Air Piston (Flow Control) Operation Adjustment

Steam damper operation was tested and adjusted prior to shipping at 80 PSI (5.51 bar). If steam damper adjustment is necessary, locate the flow control valve and make the necessary adjustments as noted below.

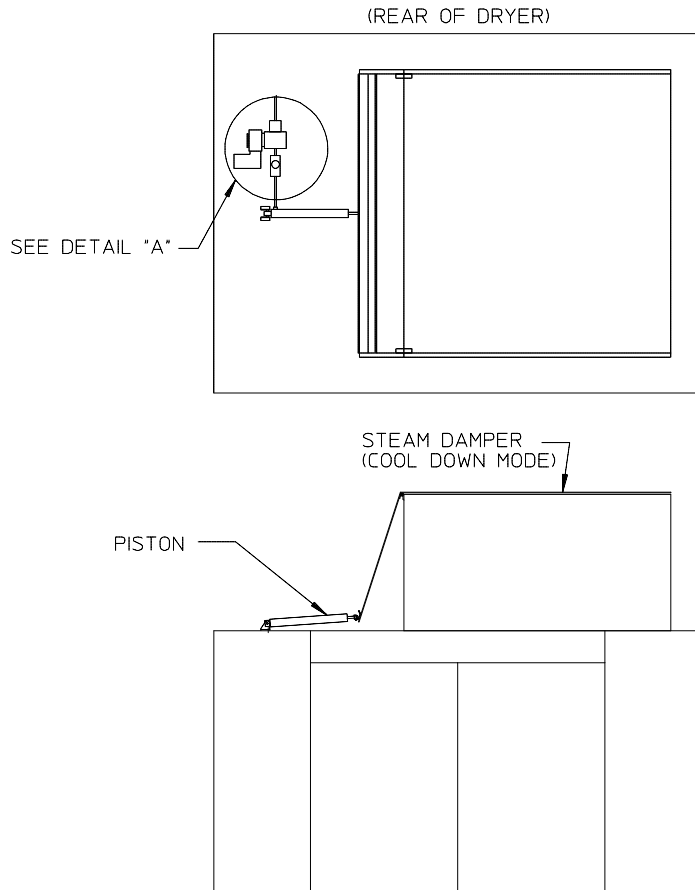

NOTE:
TURNING KNOB ON FLOW CONTROL
RESTRICT AIR FLOW. TURNING
COUNTER-CLOCKWISE WILL
ALLOW HIGHER AIR FLOW.

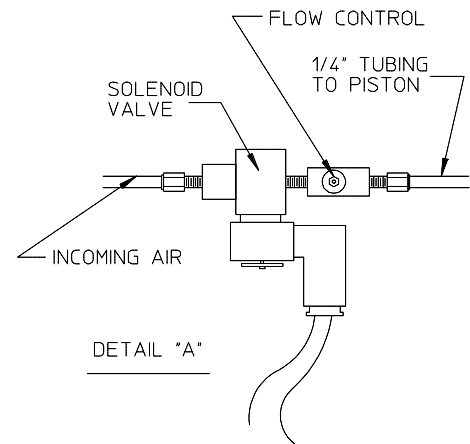

MAN0980

J. PREOPERATIONAL TEST

ALL dryers are thoroughly tested and inspected before leaving the factory. However, a preoperational test **should be** performed before the dryer is publicly used. It is possible that adjustments have changed in transit or due to marginal location (installation) conditions. Installer must instruct the user on how to correctly operate the dryer before leaving.

1. Turn on electric power to the dryer.
2. Make sure the loading doors are closed and the lint drawer is closed.
3. Make sure “green” power button is in and illuminated.
4. Microprocessor controller (computer) system operational test--to start the dryer:
 - a. Display will read “READY.”
 - b. Press “D” (preprogrammed) cycle key on the keypad.
5. The dryer will then start (i.e., blower, tumbler, and heat).
6. The light emitting diode (L.E.D.) display will read MANUAL DRYING CYCLE D, 00:00 MIN REMAIN.

NOTE: Press the “UP ARROW” to view the tumbler temperature at any time.

NOTE: The dryer can be stopped at any time by pressing the “STOP/CLEAR” key. If the temperature is above the Cool Down set point when the “STOP/CLEAR” is pressed, the dryer will go into a Cool Down Cycle. If the “STOP/CLEAR” key is pressed again at this point the cycle that was in progress **will be** canceled and returned to the “READY” state. If the temperature is below the Cool Down set point the cycle that was in progress **will be** canceled, and go to Wrinkle Guard.

7. When the programmed drying time has expired, the Phase 7 Non-Coin microprocessor controller (computer) will proceed into the Cool Down Cycle (mode).
8. Once the Cool Down Cycle begins at the end of the heat cycle the L.E.D. display will read COOL DOWN TEMP ___/___ MINUTE REMAINING. At the end of the heat cycle, the dryer will shut off the heat, and continue the fan and tumbler until the Cool Down Time, or temperature is reached.
9. Once the Cool Down Cycle is completed the Phase 7 Non-Coin microprocessor controller (computer) will proceed into the Wrinkle Guard Cycle. The Audio Alert tone will sound for the amount set in Audio Alert ON Time. The L.E.D. display will read “WRINKLE GUARD.” The times are fixed at 2 minutes OFF, 2 minutes ON for a max time of 99 minutes. These times are not programmable. During the ON time, the blower (fan) and the tumbler will start to rotate (without heat for 2 minutes). The Phase 7 Non-Coin microprocessor controller (computer) will repeat this process until the Maximum Wrinkle Guard On Time has expired (99 minutes). The L.E.D. display will then read “CYCLE DONE” and lockout the dryer functions until the doors are opened. It will then return to “READY.”

NOTE: Mechanical functions of the dryer **is not** allowed during the ON time. The blower (fan) **must be** OFF to perform mechanical functions. However the “STOP/CLEAR” key may be pressed at any time to end the Wrinkle Guard cycle. Mechanical functions of the dryer is allowed during the OFF time.

NOTE: Dryer can be stopped at any time by opening the main door or by pressing the “CLEAR/STOP” key. To restart the dryer, press the “ENTER/START” key or a preprogrammed cycle key (i.e., “E”).

NOTE: Pressing keypad key “A,” “B,” “C,” “D,” or “F” will also start the dryer. The six preprogrammed drying cycles (“A” thru “F”) have been stored in the microprocessor controller’s (computer’s) memory. Refer to the Programming Manual supplied with the dryer for these preprogrammed cycles.

10. Check to insure that the tumbler starts in the clockwise direction. Additionally, check the direction of the blower motor to insure that it rotates in the counterclockwise direction as viewed from the left side of the dryer. If it does, the phasing is correct. If the phasing is incorrect, reverse two (2) of the leads at L1, L2, or L3 of the power supply connections made to the dryer.

IMPORTANT: Dryer blower motor and impellor/fan shaft as viewed from the left side of the dryer must turn in the counterclockwise direction, otherwise the dryer efficiency **will be** drastically reduced, and premature component failure can result.

11. Heat Circuit Operational Test

a. Gas Models

- 1) When the dryer is first started (during initial start-up), the burner has a tendency not to ignite on the first attempt. This is because the gas supply piping is filled with air, so the dryer may have to be stopped and restarted several times for this air to be purged from the lines.
- 2) The dryer has one (1) burner box, which has its own Direct Spark Ignition (DSI) module and Spark Ignition/Flame-Probe Assembly. If ignition is is not established after first attempt, the heat circuit DSI module will lockout until it is manually reset. To reset the DSI system, open and close the loading doors and restart the dryer (press “ENTER/START” key).

NOTE: During the purging period, verify that **ALL** gas shutoff valves are open.

- 3) Once ignition is established, a gas pressure test **should be** taken at the gas valve pressure tap of the dryer to assure that the water column pressure is correct and consistent.

NOTE: Water column pressure requirements (measured at both gas valve pressure taps)...

Natural Gas ----- 3.5 inches (8.7 mb) water column.
Liquid Propane ----- 10.5 inches (26.1 mb) water column.

IMPORTANT: There is no regulator provided in a liquid propane dryer. The water column pressure ***must be*** regulated at the source (liquid propane tank), or an external regulator ***must be*** added to each dryer.

b. Steam Models

- 1) Check to ensure that the steam damper is functioning properly.

- 2) Make a complete operational check of **ALL** safety related circuits (i.e., lint drawer switch and sail switch on gas models).
- 3) Reversing tumbler dryers **should never be** operated with less than a 132 lb (59.9 kg) load (dry weight), since the load's weight affects tumbler coast time during a direction reversal command. It is important that the tumbler come to a complete stop prior to starting in opposite direction. For automatic (mode) cycle only, the spin and dwell (stop) times are not adjustable and have been preprogrammed into the microprocessor controller (computer) for a 2-1/2 minute reverse spin time and a 7-second dwell (stop) time.

TUMBLER COATING

The tumbler is treated with a protective coating. We suggest dampening old garments or cloth material with a solution of water and nonflammable mild detergent and tumbling them in the tumbler to remove this coating.

- 4) Each dryer **should be** operated through one (1) complete cycle to assure that no further adjustments are necessary and that **ALL** components are functioning properly.
- 5) Microprocessor controller (computer) programs/selections...
 - a) Each microprocessor controller (computer) has been preprogrammed by the factory with the most commonly used parameter (programs) selections. If computer program changes are required, refer to the computer programming manual which was shipped with the dryer.

K. PREPARATION FOR OPERATION/START-UP

The following items **should be** checked before attempting to operate the dryer:

1. Read **ALL** "CAUTION," "WARNING," and "DIRECTION" labels attached to the dryer.
2. Check incoming supply voltage to be sure that it is the same as indicated on the dryer data label affixed to the right electrical control panel. In case of 208 VAC, for dryers with sprinkler option, verify single-phase (1Ø) voltage is correct. The supply voltage must match the electrical service **exactly**.
3. **GAS MODELS** - check to assure that the dryer is connected to the type of heat/gas indicated on the dryer data label.
4. **GAS MODELS** - the sail switch damper assembly was installed and adjusted at the factory prior to shipping. However, each sail switch adjustment **must be** checked to assure that this important safety control is functioning.
5. **GAS MODELS** - be sure that **ALL** gas shutoff valves are in the open position.
6. Be sure **ALL** side and base panels are on the dryer.
7. Check **ALL** service doors to assure that they are closed and secure.
8. Be sure lint drawer is securely in place.

NOTE: LINT DRAWER *MUST BE* ALL THE WAY IN PLACE TO ACTIVATE SAFETY SWITCH OTHERWISE THE DRYER WILL NOT START.

9. Rotate the tumbler by hand to be sure it moves freely.

L. SHUTDOWN INSTRUCTIONS

If the dryer is to be shutdown (taken out of service) for a period of time, the following **must be** performed:

1. Discontinue power to the dryer either at the external disconnect switch or the circuit breaker.
2. Discontinue the heat supply:
 - a. ***GAS MODELS...discontinue the gas supply.***
 - 1) SHUT OFF external gas supply shutoff valve.
 - 2) SHUT OFF internal gas supply shutoff valve located in the gas valve burner area.
 - b. ***STEAM MODELS...discontinue steam supply.***
 - 1) SHUT OFF external (location furnished) shutoff valve.
 - 2) SHUT OFF internal steam valves in the supply lines and the return lines.

SECTION IV

SERVICE / PARTS INFORMATION

A. SERVICE

1. Service **must be** performed by a qualified trained technician, service agency, or gas supplier. If service is required, contact the reseller from whom the **ADC** equipment was purchased. If the reseller **cannot** be contacted or is unknown, contact the **ADC** Service Department for a reseller in your area.

NOTE: When contacting the **ADC** Service Department, be sure to give them the correct **model number** and **serial number** so that your inquiry is handled in an expeditious manner.

B. PARTS

1. Replacement parts **should be** purchased from the reseller from whom the **ADC** equipment was purchased. If the reseller **cannot** be contacted or is unknown, contact the **ADC** Parts Department for a reseller in your area. Parts may also be purchased directly from the factory by calling the **ADC** Parts Department at +1 (508) 678-9000 or you may FAX in your order at +1 (508) 678-9447.

NOTE: When ordering replacement parts from the **ADC** reseller or the **ADC** factory be sure to give them the correct **model number** and **serial number** so that your parts order can be processed in an expeditious manner.

SECTION V

WARRANTY INFORMATION

A. RETURNING WARRANTY CARDS

1. Before any dryer leaves the **ADC** factory test area, a warranty card is placed on the back side of the main door glass. These warranty cards are intended to serve the customer where we record the individual installation date and warranty information to better serve you should you file a warranty claim.
 - a. If a warranty card did not come with your dryer, contact the **ADC** Warranty Department or the **ADC** Service Department at +1 (508) 678-9000.

IMPORTANT: A separate warranty card *must be* completed and returned for each individual dryer.

NOTE: Be sure to include the installation date when returning the warranty card(s).

B. WARRANTY

For a copy of the **ADC** commercial warranty covering your particular dryer(s), contact the **ADC** reseller from whom you purchased the equipment and request a dryer warranty form. If the reseller **cannot** be contacted or is unknown, warranty information can be obtained from the factory by contacting the **ADC** Warranty Department at +1 (508) 678-9000.

NOTE: Whenever contacting the **ADC** factory for warranty information, be sure to have the dryer's **model number** and **serial number** available so that your inquiry can be handled in an expeditious manner.

C. RETURNING WARRANTY PARTS

ALL dryer or parts warranty claims or inquires **should be** addressed to the **ADC** Warranty Parts Department. To expedite processing, the following procedures **must be** followed:

1. No parts are to be returned to **ADC** without prior written authorization (“Return Material Authorization” [R.M.A.]) from the factory.

NOTE: An R.M.A. is valid for only thirty (30) days from date of issue.

- a. The R.M.A. issued by the factory, as well as any other correspondence pertaining to the returned part(s), **must be** included inside the package with the failed merchandise.

2. Each part **must be** tagged with the following information:
 - a. **Model number** and **serial number** of the dryer from which part was removed.
 - b. Nature of failure (be specific).
 - c. Date of dryer installation.
 - d. Date of part failure.
 - e. Specify whether the part(s) being returned is for a replacement, a credit, or a refund.

NOTE: If a part is marked for a credit or a refund, the invoice number covering the purchase of the replacement part **must be** provided.

NOTE: Warranty tags (ADC Part No. 450064) are available at “no charge” from ADC upon request.

3. The company returning the part(s) must clearly note the complete company name and address on the outside of the package.
4. **ALL** returns **must be** properly packaged to insure that they are not damaged in transit. *Damage claims are the responsibility of the shipper.*

IMPORTANT: No replacements, credits, or refunds **will be** issued for merchandise damaged in transit.

5. **ALL** returns **should be** shipped to the ADC factory in such a manner that they are insured and a proof of delivery can be obtained by the sender.
6. **Shipping charges are not the responsibility of ADC. ALL returns should be “prepaid” to the factory. Any “C.O.D.” or “COLLECT” returns will not be accepted.**

IMPORTANT: No replacements, credits, or refunds **will be** issued if the claim **cannot** be processed due to insufficient information. The party filing the claim **will be** notified in writing, either by “FAX” or “CERTIFIED MAIL - Return Receipt Requested,” as to the information necessary to process claim. If reply **is not** received by the ADC Warranty Department within thirty (30) days from the FAX/letter date, then no replacements, credits, or refunds **will be** issued, and the merchandise **will be** discarded.

SECTION VI

ROUTINE MAINTENANCE

A. CLEANING

A program and/or schedule **should be** established for periodic inspection, cleaning, and removal of lint from various areas of the dryer, as well as throughout the ductwork system. The frequency of cleaning can best be determined from experience at each location. Maximum operating efficiency is dependent upon proper air circulation. The accumulation of lint can restrict this airflow. If the guidelines in this section are met, an ADC dryer will provide many years of efficient, trouble free, and most importantly, safe operation.

WARNING: LINT FROM MOST FABRICS IS HIGHLY COMBUSTIBLE. THE ACCUMULATION OF LINT CAN CREATE A POTENTIAL FIRE HAZARD.

WARNING: KEEP DRYER AREA CLEAR AND FREE FROM COMBUSTIBLE MATERIALS, GASOLINE, AND OTHER FLAMMABLE VAPORS AND LIQUIDS.

NOTE: Suggested time intervals shown are for average usage, which is considered six (6) to eight (8) operational (running) hours per day.

IMPORTANT: Dryer produces combustible lint and *must be* exhausted to the outdoors. Every 6 months, inspect the exhaust ducting and remove any lint build up.

SUGGESTED CLEANING SCHEDULE

EVERY THIRD OR FOURTH LOAD

Clean the lint basket. A clogged lint basket will cause poor dryer performance. The lint basket is located in the lint drawer in the base of the dryer. Pull out the lint drawer, brush the lint off the lint basket, and remove the lint. Inspect lint screen and replace if torn.

NOTE: Frequency can best be determined at each location.

WEEKLY

Open the hinged panels on each side of the tumbler section and remove any lint accumulation, from the tumbler drive motor, drive shafts, V-belts, drive wheels, and drive shaft bearings.

Slide the lint basket **ALL** the way out of the dryer and clean any lint accumulation off of the temperature sensor bracket, which is located above the lint basket.

WARNING: TO AVOID THE HAZARD OF ELECTRICAL SHOCK, DISCONTINUE ELECTRICAL SUPPLY TO THE DRYER.

EVERY 3 MONTHS

Retighten setscrews in the collars of the four (4) 1-1/2" diameter tumbler drive shaft bearings.

Clean lint accumulation from the gas valve/burner area at the top of the dryer, the fan (impellor) motor, and the fan/impellor bearings located in the dryer's base.

NOTE: To prevent damage, avoid cleaning and/or touching ignitor/flame-probe assembly.

STEAM MODELS - Clean the steam coil fins. We suggest using compressed air and a vacuum cleaner with brush attachment.

NOTE: When cleaning steam coil fins, be careful not to bend the fins. If fins are bent, straighten by using a fin comb, which is available from local air-conditioning supply houses.

Inspect and remove lint accumulation in customer furnished exhaust ductwork system and from dryer's internal exhaust ducting.

CAUTION: THE ACCUMULATION OF LINT IN THE EXHAUST DUCTWORK CAN CREATE A POTENTIAL FIRE HAZARD.

NOTE: DO NOT OBSTRUCT THE FLOW OF COMBUSTION AND VENTILATION AIR. CHECK CUSTOMER FURNISHED BACK DRAFT DAMPERS IN THE EXHAUST DUCTWORK. INSPECT AND REMOVE ANY LINT ACCUMULATION, WHICH CAN CAUSE THE DAMPER TO BIND OR STICK.

NOTE: When cleaning the dryer cabinet(s), avoid using harsh abrasives. A product intended for the cleaning of appliances is recommended.

B. ADJUSTMENTS

7 DAYS AFTER INSTALLATION AND EVERY 6 MONTHS THEREAFTER

Inspect bolts, nuts, screws, (bearing setscrews), grounding connections, and nonpermanent gas connections (unions, shutoff valves, and orifices). Motor and drive belts **should be** examined. Cracked or seriously frayed belts **should be** replaced. Tighten loose V-belts when necessary. Complete operational check of controls and valves. Complete operational check of **ALL** safety devices (door switch, lint drawer switch, sail switch, burner, and hi-limit thermostats).

30 DAYS AFTER INSTALLATION

SHUT OFF ALL POWER TO THE DRYER. Verify that the electrical connections to the motor contactors and overloads are tight. This is done to accommodate the compression of the wires over time.

C. LUBRICATION

MONTHLY

The two (2) bearings that support the impellor/fan shaft **must be** lubricated. Use Shell Alvania #2 grease or its equivalent. Generically, this grease would be described as an NLGI Grade 2 multipurpose industrial grease with a lithium thickener and mineral base oil.

EVERY 3 MONTHS

The four (4) bearings that support the drive and idler shafts **must be** lubricated. Use Shell Alvania #2 grease or its equivalent. Generically, this grease would be described as an NLGI Grade 2 multipurpose industrial grease with a lithium thickener and mineral base oil.

EVERY 6 MONTHS

Remove the gear oil in the tumbler drive shaft gear reducer. Replace with 1.4 liters of Mobil oil DTE HH5G ISO viscosity grade 460 or its equivalent.

SECTION VII

COMPONENT SYSTEM DESCRIPTIONS

A. TUMBLER DRIVE SYSTEM

The tumbler is supported and driven by four (4) 11-inch diameter drive wheels. Two (2) of these wheels are attached to a 1-1/2" diameter idler shaft, while the other two (2) are attached to a 1-1/2" diameter drive shaft. Each of the wheels is fastened to the shafts by a taper lock bushing. The taper lock is made up of three (3) pieces: an inner collar, an outer sleeve, and a key. The inner and outer elements have matching opposing tapers. As a result, when the bolts are tightened, the taper lock contracts onto the shaft and expands into the drive wheel hub locking the wheel onto the shaft.

The idler shaft and drive shaft are each supported by two (2) 1-1/2" diameter pillow block bearings. These bearings sit on slotted support channels and can be moved inward or outward by the adjustment bolts to raise or lower the tumbler.

The drive system consists of a shaft mounted pulley, two (2) V-belts, and a 3 hp (2.24 kW) drive motor. Belt tension can be adjusted by tightening or loosening the gear reducer turnbuckle.

TUMBLER DRIVE SYSTEM

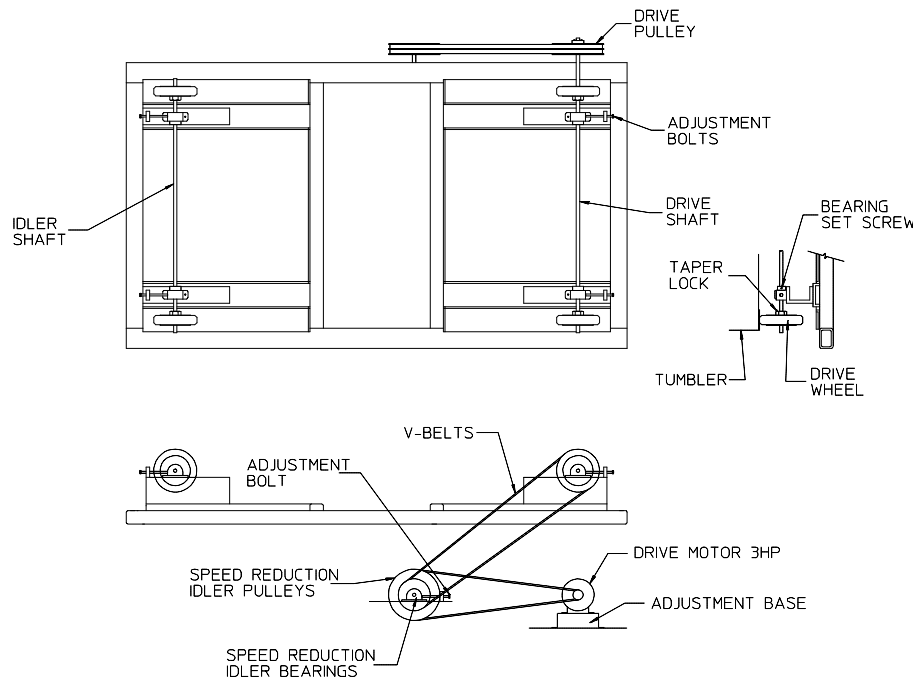

MAN4499

WHEN REPLACING A DRIVE WHEEL:

1. ALWAYS CHANGE BOTH WHEELS ON A SHAFT.
2. MARK POSITION OF BEARINGS ON SUPPORTS. THIS WILL MAKE REASSEMBLY OF SHAFT AND CENTERING OF TUMBLER EASIER.
3. SHOVE BLOCKS OF WOOD UNDER TUMBLER TO TAKE IT'S WEIGHT OFF OF DRIVE WHEELS.
4. REMOVE BEARING HOLD DOWN BOLTS AND ADJUSTMENT BOLTS.
5. IF DRIVE SHAFT IS BEING REMOVED, TAKE OFF DRIVE PULLEY.
6. SLIDE COMPLETE SHAFT ASSEMBLY OUT OF SIDE OF DRYER.

B. TUMBLER

The tumbler is made of 14-gauge stainless steel perforated panels, four (4) stainless steel ribs, and two (2) outer tumbler rings made of rolled steel angle iron that has been turned on a lathe for smoothness. The tumbler is a completely welded assembly, so the perforated panels are not removable.

C. AIR BLOWER DRIVE SYSTEM

The impellor (fan) used in the dryer is a 15-inch diameter squirrel cage impellor (fan) wheel. It spins in a counterclockwise direction looking at the back of the blower housing.

The impellor (fan) shaft is mounted in two (2) pillow block bearings, and the shaft is driven by two (2) B-section V-belts connected to the blower motor.

The blower motor is mounted on an adjustable base. The motor position can be easily adjusted, so that proper tension can be maintained on the V-belts.

D. SAFETY DEVICES

1. Load/Unload Door Switches

There are two (2) of these switches located above the main loading doors. These switches ensure that the doors are closed before the dryer can start and ensures that the doors are fully open before the dryer will tilt. If the dryer is started when the load doors are open, the microprocessor controller (computer) light emitting diode (L.E.D.) display will show “front door not closed” or “rear door not closed” for 2 door dryers.

2. Lint Basket Switch

This switch ensures that the lint basket is closed before the dryer can start. This switch is located at the front of the dryer at the right side of the lint basket. If the lint basket is open when the dryer is started, the microprocessor controller (computer) L.E.D. will display “Lint Drawer Open” and will not reset until the lint drawer has been closed. For a “clean lint” prompt the lint drawer must remain open for 15-seconds.

3. Automatic Reset Tumbler Hi-Limit Safety Thermostat

The automatic reset tumbler hi-limit switch is a thermostat type switch located above the lint basket. Its function is to discontinue heat (flame) in the event of an over temperature situation (above 225° F [107° C]). This will shut off the gas flow to the burner boxes; and the display will read an error code of “tumbler hi-limit fault.” The automatic reset hi-limit safety will automatically reset once the temperature has fallen below 225° F (107° C). The Phase 7 computer **must be** reset by pressing the Stop key, then the display will read “READY.”

4. Manual Reset Burner Hi-Limit Safety Thermostats (for Gas Dryers Only)

These disk temperature switches have a setting of 330° F (166° C). They are located on the right side of each burner box, and they are a manual reset type of switch. These switches ensure that there is a proper airflow through the burner box. Upon a low airflow condition, which may be caused by a clogged lint screen excessively long or blocked exhaust duct, or improper make-up air, the temperature in the burner boxes will increase tripping these switches. This will shut off the gas flow to the burner boxes; and the display will read an error code of “Burner Hi-Limit Fault.” The thermostat **must be** manually reset and the Phase 7 computer **must be** reset.

5. Sail Switch (for Gas Dryers Only)

The sail switch is located in the front of the burner box. A sail switch consists of a round damper plate on a lever arm, which is in contact with an electric switch. When the air blower comes on, it draws air through the gas burner. This creates a negative pressure inside the burner box. This negative pressure pulls in the sail switch. If the sail switch does not pull in, this will prevent the dryer from operating and a sail switch fault will display.

NOTE: An overly long or blocked exhaust duct, lack of make-up air, or clogged lint screen will prevent the sail switches from pulling in.

E. STEAM DAMPER ACTUATOR SYSTEM

The system consists of a hinged damper plate, a pneumatic piston (with an airflow needle valve) to control the speed of the piston actuation, and a 24 volt solenoid valve.

On a call for heat, a 24 volt signal is applied to the 3-way/2-position solenoid valve. This signal switches the valve so that compressed air is sent to the piston. The piston rod extends, pushing the the hinged steam damper plate to the opened position. This allows room air to be drawn through the hot steam coil and then through the tumbler.

When the temperature set point has been reached, the 24 volt signal is removed from the solenoid valve, so that the solenoid valve blocks the air supply to the pistons, and the air in the pistons is bled to the atmosphere. The springs in the pistons now retract the piston rods, closing the steam damper. The steam damper plate now covers the steam coil and allows room air to bypass the coil before entering the tumbler for a rapid cool down.

The steam damper plate should open and close slowly and smoothly. The speed can be modulated by adjusting both needle valve knobs. Turning the knob clockwise restricts the compressed airflow and slows down the steam damper movement. Counterclockwise adjustment speeds up the steam damper motion. Upon completion of adjustment, tighten the needle valve's locking nut.

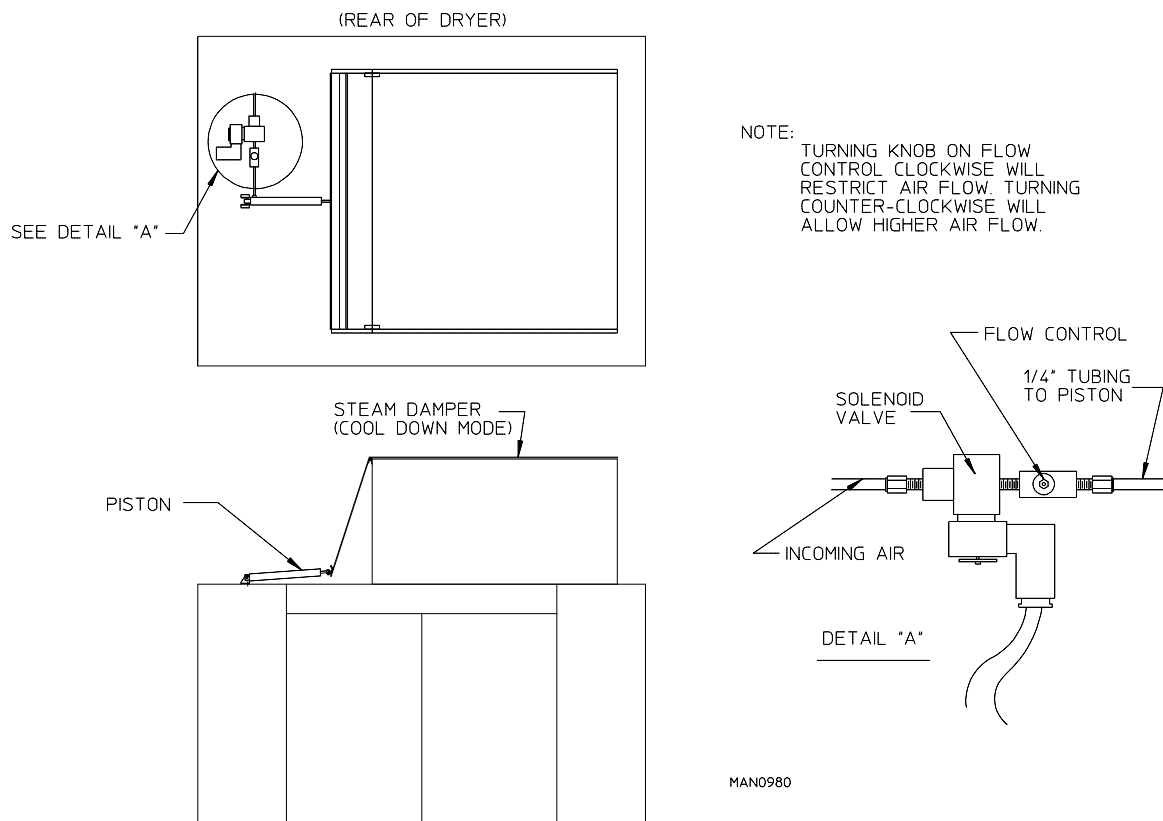

NOTE: Turning knob on flow control clockwise will restrict airflow. Turning knob counterclockwise will allow higher airflow.

SECTION VIII

MANUAL RESET BURNER HI-LIMIT INSTRUCTIONS

IMPORTANT

MANUAL RESET HI-LIMIT INSTRUCTIONS

FOR PHASE 7 MODELS

This dryer was manufactured with a manual reset burner hi-limit, which is monitored by the Phase 7 computer. If the burner is open prior to start of the drying cycle, the dryer will start momentarily and then shutdown, the Phase 7 computer will display “burner HIGH LIMIT fault” with an audio indication.

If the burner hi-limit thermostat opens during a drying cycle, the Phase 7 computer will also display the same error code described above, along with an audio indication. If the drum temperature is above 100° F (38° C), the dryer will continue to run with no heat for 3 minutes or until the drum temperature has dropped below 100° F (38° C). The clear/stop button on the Phase 7 keypad **must be** pressed to clear the error condition. The open manual reset hi-limit thermostat **must be** reset “manually” prior to the start of the next cycle.

This hi-temperature condition may be caused due to a restricted exhaust, poor airflow, or improper burner operation.

The location of the burner hi-limit is on the right side of the burner box, looking at the burner from the back of the dryer.

WARNING: Discontinue power to dryer before attempting to reset hi-limit.

IMPORTANT IMPORTANT IMPORTANTE

HEATING UNIT IS EQUIPPED WITH A HI-LIMIT
THERMOSTAT WHICH *MUST BE RESET MANUALLY.*

WARNING - DISCONTINUE POWER TO DRYER
BEFORE ATTEMPTING TO RESET HI-LIMIT.

L'ÉLÉMENT CHAUFFANT EST ÉQUIPÉ D'UN THERMOSTAT À
LIMITE MAXIMALE QUI *DOIT ÊTRE RÉGLÉ MANUELLEMENT.*

MISE EN GARDE - COUPER LE COURANT D' ALIMENTATION DU
SÈCHE-LINGE AVANT DE RÉGLER LA LIMITE MAXIMALE.

LA UNIDAD DE CALENTAMIENTO ESTÁ EQUIPADA CON UN TERMOSTATO
DE LÍMITE SUPERIOR *QUE DEBE REINICIARSE MANUALMENTE.*

ADVERTENCIA - DESCONECTE LA ALIMENTACIÓN ELÉCTRICA
A LA SECADORA ANTES DE REINICIAR EL LÍMITE SUPERIOR.

ADC P/N: 114076

SECTION IX

DATA LABEL INFORMATION

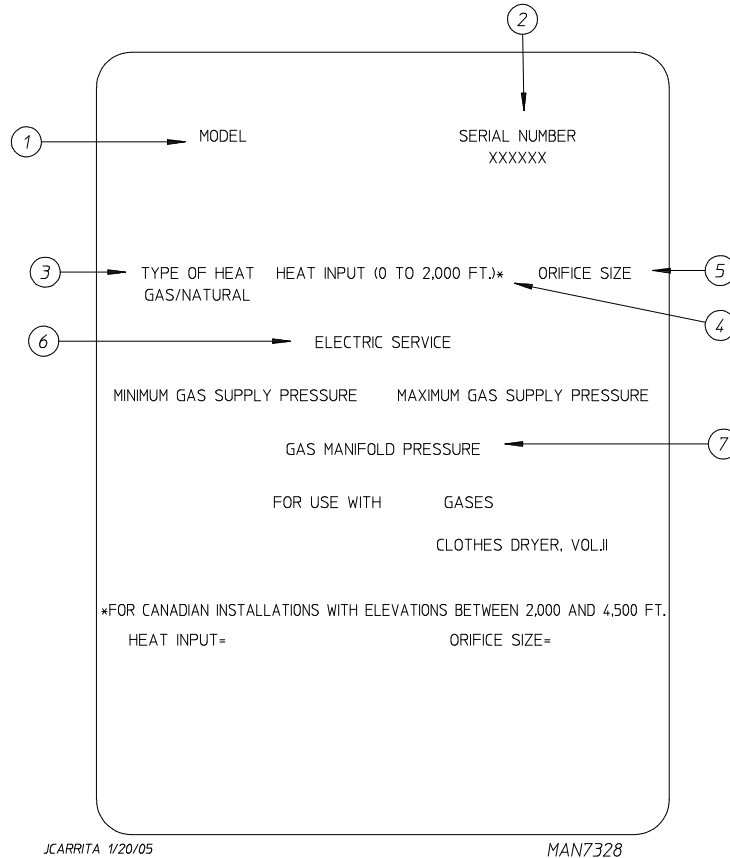

When contacting **American Dryer Corporation**, certain information is required to insure proper service/parts information from **ADC**. This information is on the data label that is affixed to the right electrical control panel. When contacting **ADC**, please have the **model number** and **serial number** available.

1. **MODEL NUMBER** – This describes the style of dryer and type of heat (gas, electric, or steam).
2. **SERIAL NUMBER** – Allows the manufacturer to gather information on your particular dryer.
3. **TYPE OF HEAT** – This describes the type of heat for your particular dryer, gas (either natural gas or L.P. gas), electric, or steam.
4. **HEAT INPUT** (For Gas Dryers) – This describes the heat input in British thermal units per hour (Btu/hr) or kilowatts (kW).
5. **ORIFICE SIZE** (For Gas Dryers) – Gives the number drill size used.
6. **ELECTRIC SERVICE** – This describes the voltage and current rating for a particular model.
7. **GAS MANIFOLD PRESSURE** (For Gas Dryers) – This describes the manifold pressure taken at the gas valve tap.

SECTION X

PROCEDURE FOR FUNCTIONAL CHECK OF REPLACEMENT COMPONENTS

1. For Models with Direct Spark Ignition (DSI) Module (Type I)

Theory of Operation:

Start the drying cycle. When the gas burner ignites within the chosen trial for ignition time (6-seconds), the flame sensor detects gas burner flame and signals the DSI module to keep the gas valve open as long as there is a call for heat. The DSI module will “LOCKOUT” if the gas burner flame is not sensed at the end of the trial for ignition period. The trial for ignition period will be repeated for a total of three (3) retries/trials (the initial try and two [2] more retries/trials). If the flame is not sensed at the end of the third retry/trial (inter-purge period of 30-seconds) the DSI module will “LOCKOUT” (light emitting diode [L.E.D.] diagnostic indicator flashes).

A steady L.E.D. indicator indicates normal operation.

No L.E.D. indicator indicates a power or an internal failure has occurred.

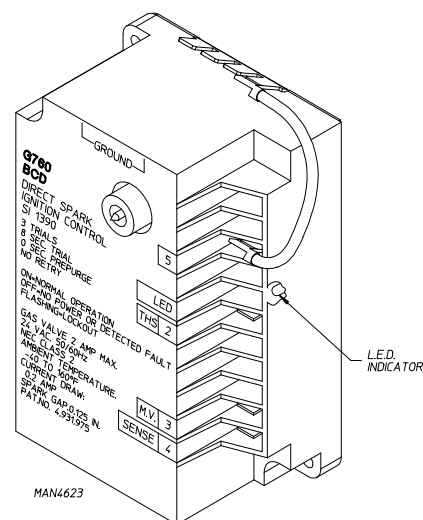

2. For Models with DSI Module (Type II)

Theory of Operation:

Start the drying cycle. When the gas burner ignites within the chosen trial for ignition time (8-seconds), the flame sensor detects gas burner flame and signals the DSI module to keep the gas valve open as long as there is a call for heat. The DSI module will “LOCK OUT” if the gas burner flame is not sensed at the end of the trial for ignition period. The trial for ignition period will be repeated for a total of three (3) retries/trials (the initial try and two [2] more retries/trials). If the flame is not sensed at the end of the third retry/trial (inter-purge period of 30-seconds), the DSI module will “LOCK OUT” (a red L.E.D. diagnostic indicator will flash).

An unlit red L.E.D. diagnostic indicator indicates normal operation.

A lit green L.E.D. diagnostic indicator indicates dryer controller is calling for heat and that **ALL** interlocks have been satisfied.

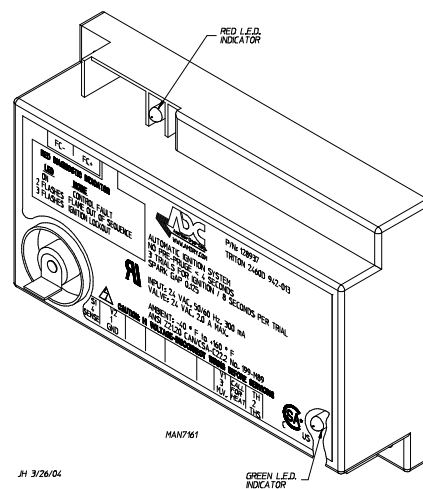

SECTION XI

OPTIONAL SENSOR ACTIVATED FIRE EXTINGUISHING (S.A.F.E.) SYSTEM

S.A.F.E. SYSTEM IN ACTION

The exclusive Sensor Activated Fire Extinguishing (S.A.F.E.) System will extinguish fires that may start in the drying tumbler. A series of sensors positioned throughout the tumbler and interfaced with the microprocessor will trigger the S.A.F.E. system water jet(s) to quickly extinguish the flames. The water jet(s) remain on for 2 minutes and will automatically activate again if a fire condition remains or reignites. While the water jet(s) are activated, the tumbler will jog to move the water throughout the load. The microprocessor will display that the system was activated and will continue to display until the dryer is attended to.

We have tried to make this manual as complete as possible and hope you will find it useful. **ADC** reserves the right to make changes from time to time, without notice or obligation, in prices, specifications, colors, and material, and to change or discontinue models.

BEFORE YOU START!

CHECK LOCAL CODES AND PERMITS

Call your local water company or the proper municipal authority for information regarding local codes.

IMPORTANT: It is your responsibility to have **ALL** plumbing connections made by a qualified professional to assure that the plumbing installation is adequate and conforms to local, state, and federal regulations or codes.

IMPORTANT: It is the installation or owners responsibility to see that the necessary or required water, water pressure, pipe size, or connections are provided. Manufacturer assumes no responsibility if the Sensor Activated Fire Extinguishing (S.A.F.E.) System **is not** connected, installed, or maintained properly.

WARNING: Water ***must be*** supplied to S.A.F.E. system or dryer **will not** operate.

INSTALLATION

1. Requirements

The connection point to the electric water solenoid valve is a 1/2" M.P.T., the S.A.F.E. system **must be** supplied with a minimum water pipe size of 1/2-inch and be provided with 40 PSI (2.75 bar) and a maximum of 100 PSI (6.89 bar) of pressure. For use of optional manual bypass, a second source with the same piping and pressure requirements is required.

Flexible 1/2 feeds **must be** provided to avoid damage to electric water solenoid valve by vibration (for non-tilt models only).

IMPORTANT: Flexible supply line/coupling **must be** used. Solenoid valve failure due to hard plumbing connections WILL VOID WARRANTY (for non-tilt models only).

If the rear area of the dryer, or the water supply is located in an area where it will be exposed to cold/freezing temperatures, provisions **must be** made to protect these water lines from freezing.

WARNING: If the water in the supply line or water solenoid valve freezes, the S.A.F.E. system will be INOPERATIVE!!

IMPORTANT: Appliance is to be connected to the water mains using a new hose set and the old hose set **should not be** reused.

2. Water Connections:

The water connection is made to the 3/4" F.P.T. bushing of the electric water solenoid valve located at the rear upper left area of the dryer. The water solenoid valve has a 1/2" M.P.T. connection and a 1/2" bushing is supplied to provide the minimum 1/2-inch supply (feed) line. Flexible supply line/coupling **must be** used in effort to avoid damage to electric water solenoid valve.

WARNING: Water **must be** supplied to sensor activated fire extinguishing (S.A.F.E.) system or dryer will not operate.

IMPORTANT: Flexible supply line/coupling **must be** used. Solenoid valve failure due to hard plumbing connections WILL VOID WARRANTY. **It is recommended** that a filter or strainer be installed in the water supply line.

Typical water supply...

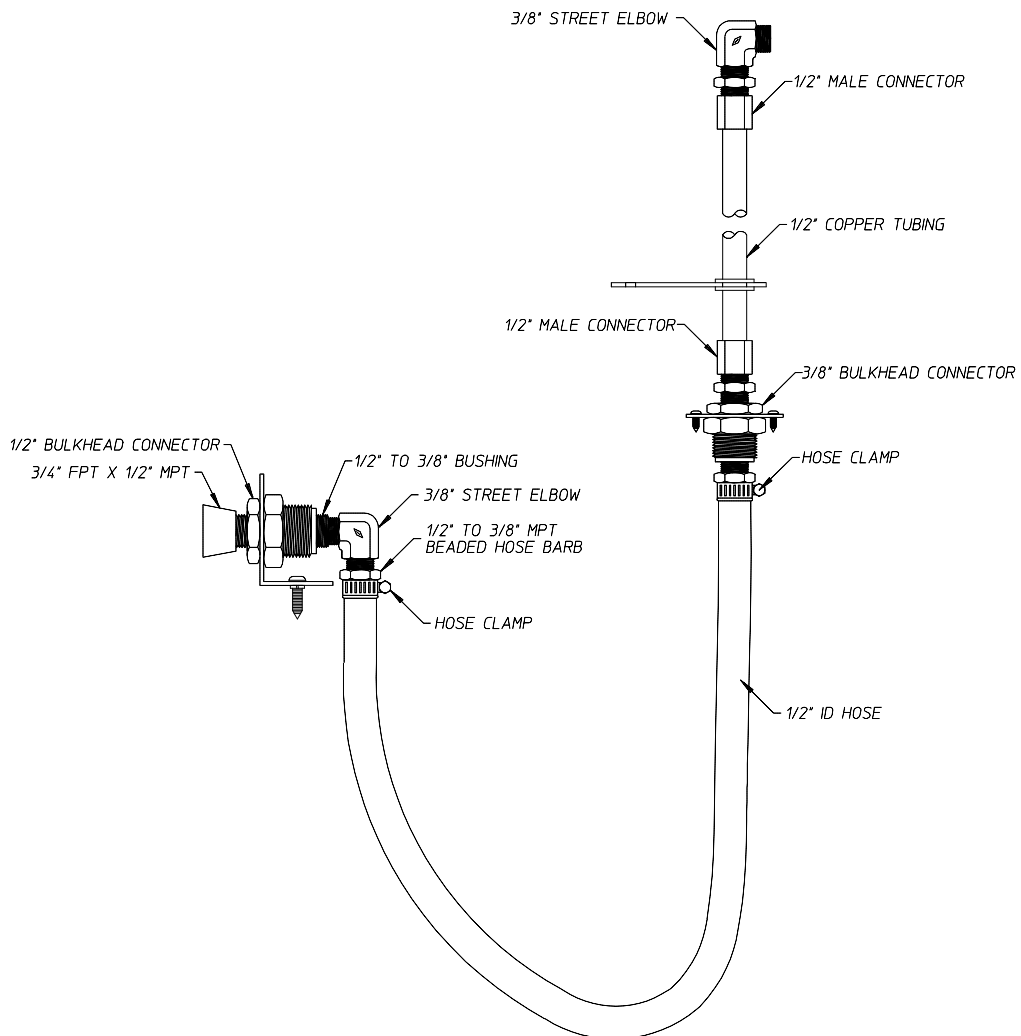
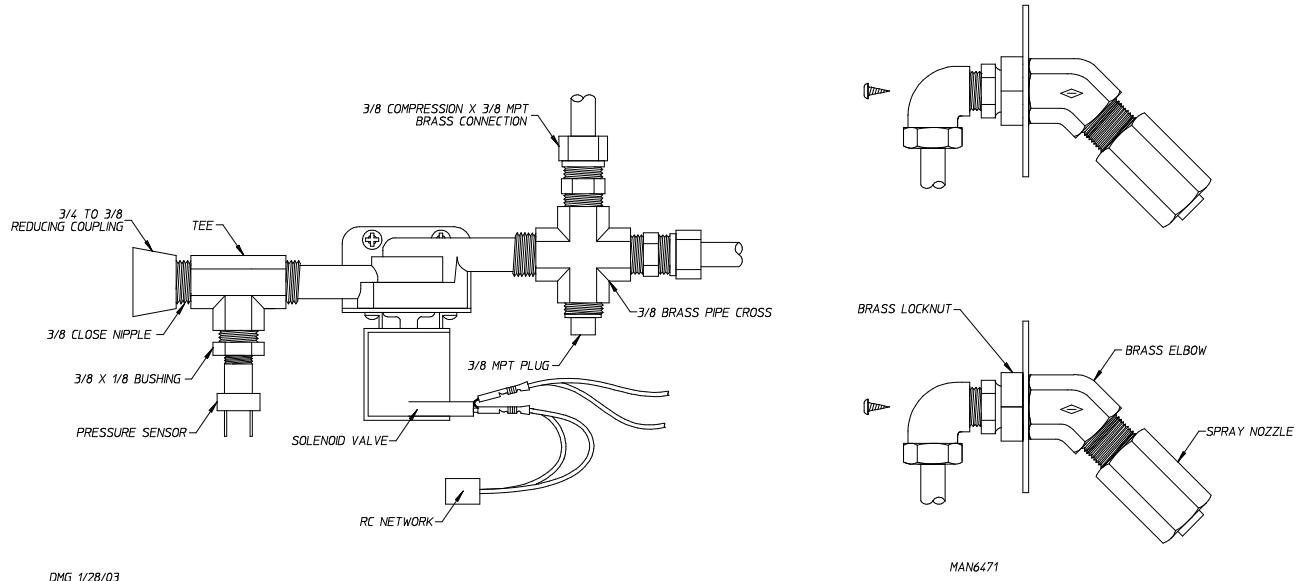

OPTIONAL MANUAL BYPASS

Provisions are made in the dryer sensor activated fire extinguishing (S.A.F.E.) system for the installation of an optional manual bypass. Depending on the model dryer, the connections for the manual bypass are made at the “T” or “four way” fitting located in the outlet supply side of the water solenoid valve. The use and connections of this manual bypass are at the option or discretion of the owner.

The water connection for the manual bypass is made to the “T” or “four way” fitting, which has a 3/8” F.P.T. and a coupling **must be** used to provide the minimum 1/2-inch supply (feed) line.

If the rear area of the dryer, or the water supply is located in an area where it will be exposed to cold/freezing temperatures, provisions **must be** made to protect these water lines from freezing.

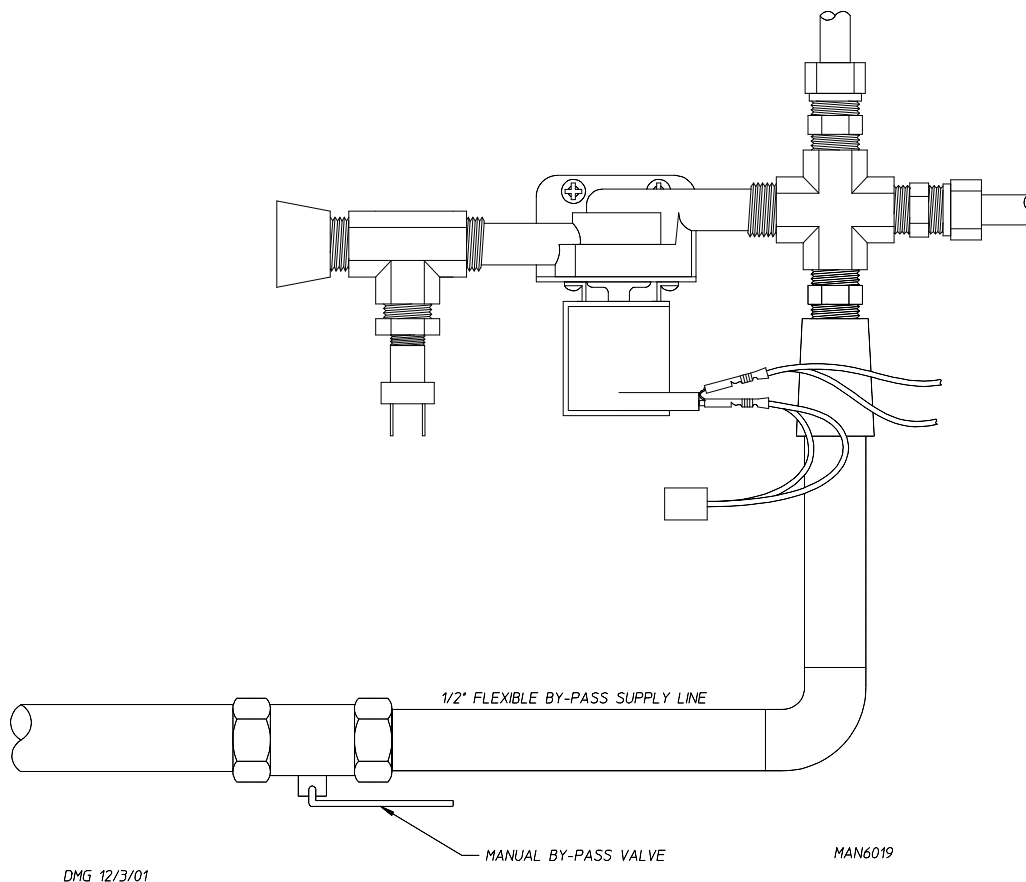

WARNING: If the water in the supply line or water solenoid valve freezes, the S.A.F.E. system **will be** INOPERATIVE!!

The manual ball cock shutoff valve **must be** located outside of the dryer at a distance from the dryer where it is easily accessible.

3. Electrical Requirements

No independent external power source or supply connection is necessary. The 24 volt power to operate the S.A.F.E. system is accomplished internally in the dryer (from the dryer controls).

WARNING: Electrical power **must be** provided to the dryer at **ALL** times. If the main electrical power supply to the dryer is disconnected, the S.A.F.E. system is INOPERATIVE!!

NOTE: S.A.F.E. system water solenoid valve test can be performed by pressing the “STOP” key and “A” key together.

S.A.F.E. SYSTEM THEORY OF OPERATION

While the dryer is in an idle state or 20-seconds after the heat turns off, the Phase 7 control monitors the S.A.F.E. system probe located in the top of the tumbler chamber and records the minimum temperature. If the minimum recorded S.A.F.E. system probe temperature is no less than 120° F (48° C) and the control detects a 50° rise in temperature, this will be the trip point and the S.A.F.E. system routine will activate.

While a drying cycle is in process and the heat has turned on at least once, the Phase 7 control monitors the exhaust temperature transducer. If the drying cycle temperature set point is set greater than 160° F (71° C) and the control detects an exhaust temperature rise 25° F greater than set point, this will be the trip point and the S.A.F.E. system routine will activate. If set point is below 160° F (71° C) the trip point will be 185° F (85° C).

Once the S.A.F.E. system routine is activated, water will be injected into the tumbler chamber. Anytime water is being injected into the tumbler; the tumbler drive will turn the load for 1-second every 15-seconds. This process will continue for a minimum of 2 minutes. After 2 minutes has elapsed, the control will check if the temperature remained above trip point, if so water will remain on. The control will continue to check if temperature is above trip point every 30-seconds. If the water has been on for a constant 10 minutes, the water will be turned off regardless of the temperature. If the temperature has dropped below trip point, the control will turn off the water prior to 10 minutes.

SYSTEM RESET

After the microprocessor determines that the situation is under control and shuts the water being injected into the tumbler off, the microprocessor display will read “S.A.F.E. System activated,” and the horn/tone will sound until reset manually.

To reset the microprocessor once the control displays “S.A.F.E. System activated,” press the red key on the keypad.

NON-COIN S.A.F.E. SYSTEM CHECK PROCEDURE

The operation of the water solenoid valve can be tested to insure that the water supply system and valve are functional. Before attempting system check, be sure that **ALL** water supply shutoff valves to the dryer are in the OPEN position, and the dryer **must be** in the “READY” mode where no cycle is loaded or in progress.

The procedure is as follows:

1. Press and hold the RED STOP key (while in “READY” mode and no cycle in progress).
2. Press and hold the “A” key.
3. Water valve will open and water will be dispensed into tumbler area as long as both keys are held.

IMPORTANT: This is a test function only and the keys *should be* held and system activated for only a second or so, otherwise water will accumulate in various places in the dryer.

SECTION XII

NON-COIN PROGRAMMING

To Enter Programming Mode
Press **0** And **▲** Keys Together
To Exit Programming Mode Press **0** Multiple Times
Until Display Returns to "Ready".

0:	SELECT LANGUAGE
1:	SELECT SYSTEM PARAMETERS
0:	DRYER SETUP
0:	SELECT MODEL
1:	SYSTEM TEMP
2:	ENTER LINT COUNT 1 TO 5
3:	ENTER AUDIO ALERT ON TIMES 0 TO 10
4:	ROTATION SENSOR
1:	REVERSING SETUP
0:	ENTER SPIN TIME 30 TO 120 SECONDS
1:	ENTER STOP TIME 5 TO 10 SECONDS
0:	WRINKLE GUARD SETUP
2:	WRINKLE GUARD AUDIO ALERT
3:	STEAM INJECTION SETUP
2:	PROGRAM A - F CYCLES
0:	ENTER A - F
1:	SELECT CYCLE TYPE
0:	AUTO
0:	REVERSE MODE
1:	ENTER DRY TEMP 160 (71) TO 200 F (94 C) *
2:	ENTER DRYNESS LEVEL
3:	ENTER CYCLE ADJUSTMENT VALUE 0 TO 99
4:	CONTROLLED COOL DOWN
5:	ENTER COOL DOWN TIME 0 TO 99 MINUTES
6:	ENTER COOL DOWN TEMP 70 (21) TO 100 F (38 C)
0:	MANUAL
0:	REVERSE MODE
1:	ENTER DRY TIME 0 TO 99 MINUTES
2:	ENTER DRY TEMP 100 (38) TO 200 F (94 C) *
3:	CONTROLLED COOL DOWN
4:	ENTER COOL DOWN TIME 0 TO 99 MINUTES
5:	ENTER COOL DOWN TEMP 70 (21) TO 100 F (38 C)
6:	STEAM INJECTION
3:	PROGRAM 0 - 40 CYCLES
0:	ENTER 0 - 40
1:	SELECT CYCLE TYPE
0:	AUTO
0:	REVERSE MODE
1:	ENTER DRY TEMP 160 (71) TO 200 F (94 C) *
2:	ENTER DRYNESS LEVEL
3:	ENTER CYCLE ADJUSTMENT VALUE 0 TO 99
4:	CONTROLLED COOL DOWN
5:	ENTER COOL DOWN TIME 0 TO 99 MINUTES
6:	ENTER COOL DOWN TEMP 70 (21) TO 100 F (38 C)
0:	MANUAL
0:	REVERSE MODE
1:	ENTER DRY TIME 0 TO 99 MINUTES
2:	ENTER DRY TEMP 100 (38) TO 200 F (94 C) *
3:	CONTROLLED COOL DOWN
4:	ENTER COOL DOWN TIME 0 TO 99 MINUTES
5:	ENTER COOL DOWN TEMP 70 (21) TO 100 F (38 C)
6:	STEAM INJECTION
4:	DEFAULT SETTING FAULT HISTORY
5:	SAFE SYSTEM VALVE TEST OR 0 + ▲

DISPLAY: **0** **▼** SAFE TEMP **▲** TUMBLER TEMP **▼** CTL VAC / RPM
* 160 F (71 C) MAXIMUM TEMP ON AXIAL MODELS

Phase 7.2 Non-Coin Diagnostic Codes

MAIN DOOR OPENED – A main door or door circuit is open.
EXHAUST HIGH TEMP FAULT – Tumbler is above 220° F (104° C).

LINT ACCESS OPEN – Lint drawer or lint door circuit is open.
EXHAUST HIGH LIMIT FAULT – Temp. disk under tumbler is open.

SAIL SWITCH CLOSED FAULT – Sail switch is closed – should be open at the start of a cycle.

SAIL SWITCH OPEN FAULT – Sail switch remained open after the cycle started. Should have closed.

BURNER HIGH LIMIT FAULT – Burner temp. disk has opened.

BURNER IGNITION CONTROL – No signal to gas valve from (DSI) module during trial for ignition time. DSI module is bad.

IGNITION FAULT – Gas valve did not remain open after trial for ignition. Indicates that no flame was detected.

FLAME FAULT – Flame was detected during trial for ignition but failed later.

ROTATION FAULT – Indicates the tumbler is not rotating.

OPEN EXHAUST TEMPERATURE PROBE – Indicates the exhaust temperature probe is open or shorted.

OPEN FIRE SUPPRESSION SYSTEM (F.S.S.) PROBE FAULT – Indicates the temperature probe for the F.S.S. is open or shorted.

LOW VOLTAGE FAULT – Volt dropped below the operating value.

EE PROM FAULT ### – Error in memory location. Fault correction:

Enter the program mode by pressing the UP and STOP keys.

Press "4" and ENTER keys in password "FAA" Press UP ARROW.

Press enter to confirm reset of EE PROM.

Inputs (Red L.E.D.s)

All indications are with L.E.D. lit

ESTOP – Indicates E-STOP has been pressed.

GAS_V – Indicates the gas valve is open (ON).

BRHL – Indicates the burner high limit disk is closed (temperature below 330° F [166° C]).

SAIL – Indicates the sail switch is closed.

EXHL – Indicates the exhaust high limit disk is closed (temperature below 225° F [107° C]).

MAIN – Indicates the status of main door is closed.

LINT – Indicates the lint drawer is closed.

FUSE – Indicates the status of the control voltage after POWER ON button has been pressed.

Outputs (Green L.E.D.s)

All indications are with L.E.D. lit

AUX – This is for a spare output to be programmed.

STEAM – Indicates the status of the steam injection output.

_HEAT – Indicates the status of the heat output.

AIR – Indicates the status of the air jet output.

REV – Indicates the status of the tumbler reverse direction output. If the request to tumble the drum in the reverse direction is made, then the L.E.D. is ON.

FWD – This L.E.D. will indicate the status of the tumbler forward direction output.

FAN – This L.E.D. will indicate the status of the fan output.

