



AD-75 Parts Manual

Phase 3 / Phase 4 / Non-Coin
1988 thru 1991

American Dryer Corporation
88 Currant Road
Fall River, MA 02720-4781
Telephone: (508) 678-9000 / Fax: (508) 678-9447
E-mail: techsupport@amdry.com

www.amdry.com

Retain This Manual In A Safe Place For Future Reference

American Dryer Corporation products embody advanced concepts in engineering, design, and safety. If this product is properly maintained, it will provide many years of safe, efficient, and trouble free operation.

ONLY qualified technicians should service this equipment.

OBSERVE ALL SAFETY PRECAUTIONS displayed on the equipment or specified in the installation manual included with the dryer.

The following “**FOR YOUR SAFETY**” caution must be posted near the dryer in a prominent location.

FOR YOUR SAFETY

Do not store or use gasoline or other flammable vapors and liquids in the vicinity of this or any other appliance.

POUR VOTRE SÉCURITÉ

Ne pas entreposer ni utiliser d'essence ni d'autres vapeurs ou liquides inflammables à proximité de cet appareil ou de tout autre appareil.

We have tried to make this manual as complete as possible and hope you will find it useful. ADC reserves the right to make changes from time to time, without notice or obligation, in prices, specifications, colors, and material, and to change or discontinue models.

Important

For your convenience, log the following information:

DATE OF PURCHASE _____ MODEL NO. **AD-75**
RESELLER'S NAME _____
Serial Number(s) _____

Replacement parts can be obtained from your reseller or the ADC factory. When ordering replacement parts from the factory, you can FAX your order to ADC at (508) 678-9447 or telephone your order directly to the ADC Parts Department at (508) 678-9000. Please specify the dryer model number and serial number in addition to the description and part number, so that your order is processed accurately and promptly.

The illustrations on the following pages may not depict your particular dryer exactly. The illustrations are a composite of the various dryer models. Be sure to check the descriptions of the parts thoroughly before ordering.

“IMPORTANT NOTE TO PURCHASER”

Information must be obtained from your local gas supplier on the instructions to be followed if the user smells gas. These instructions must be posted in a prominent location near the dryer.

Table of Contents

High Security Control Door Assembly	4
Phase 4 Non-Coin Microprocessor Control Panel Assembly	5
Phase 4 Non-Coin Microprocessor Control Box Assembly	6
Phase 3 Non-Coin Microprocessor Control Panel Assembly	7
Phase 3 Non-Coin Microprocessor Control Box Assembly	8
Dual Timer Control Panel Assembly	9
Dual Timer Control Box Assembly	10
Front Panel Assembly – Latch Type	12
Front Panel Assembly – Magnet Type	13
Main Door Assembly – Latch Type	14
Main Door Assembly – Magnet Type	15
Main Door Switch Assembly – N.S. Series	16
Main Door Switch Assembly – Plunger Type	17
Lint Trap Assembly for Steam Models with 10" Exhaust Mfd. as of October 25, 1991	18
Lint Trap Assembly for Gas and Steam Models with 8" Exhaust Mfd. prior to October 25, 1991	19
Drop Lint Door Assembly	20
Tumbler / Support Assembly	21
Tumbler Bearing Assembly	22
Idler Bearing Assembly	23
Non-Reversing T.E.F.C. Motor Mount Assembly for Models Mfd. without Slanted / Tapered Tumbler Ribs	24
Reversing T.E.F.C. Motor Mount Assembly for Models Mfd. without Slanted / Tapered Tumbler Ribs	26
Sensor Bracket Assemblies	28
Direct Spark Ignition Upshot Burner Assembly	30
Electric Oven Assembly for Models Mfd. as of November 12, 1990	32
Electric Oven Assembly for Models Mfd. prior to November 12, 1990	34
3-Phase (3Ø) Motor, Electric Relay Panel Assembly for Models Mfd. with 208-240 Volt Controls – Telemecanique	36
3-Phase (3Ø) Motor, Electric Relay Panel Assembly for Models Mfd. with 208-240 Volt Controls – Furnas	37
Microprocessor Reversing Rear Control Box Assembly for Models Mfd. with 208-240 Volt Controls – Telemecanique for Models Mfd. as of December 1, 1988	38
Microprocessor Reversing Rear Control Box Assembly for Models Mfd. with 208-240 Volt Controls – Struthers-Dunn for Models Mfd. prior to December 1, 1988	39
Dual Timer Reversing Rear Control Box Assembly for Models Mfd. with 208-240 Volt Controls – Telemecanique	40
Dual Timer Reversing Rear Control Box Assembly for Models Mfd. with 208-240 Volt Controls – Struthers-Dunn	41
Air-Operated Steam Damper Assembly for Models Mfd. as of October 1, 1991	42
Motorized or Solenoid Steam Valve / Coil Assembly	43
Motorized Steam Valve Step Down Transformer	44
Outer Top / Back Guard Assemblies for Gas and Electric Models ONLY	45
Back Guard Assembly for Steam Models ONLY	46
Electric Oven Component Application Chart for Models Mfd. as of November 12, 1990	47
Electric Oven Component Application Chart for Models Mfd. prior to November 12, 1990	48
Additional Parts Available	49

High Security Control Door Assembly

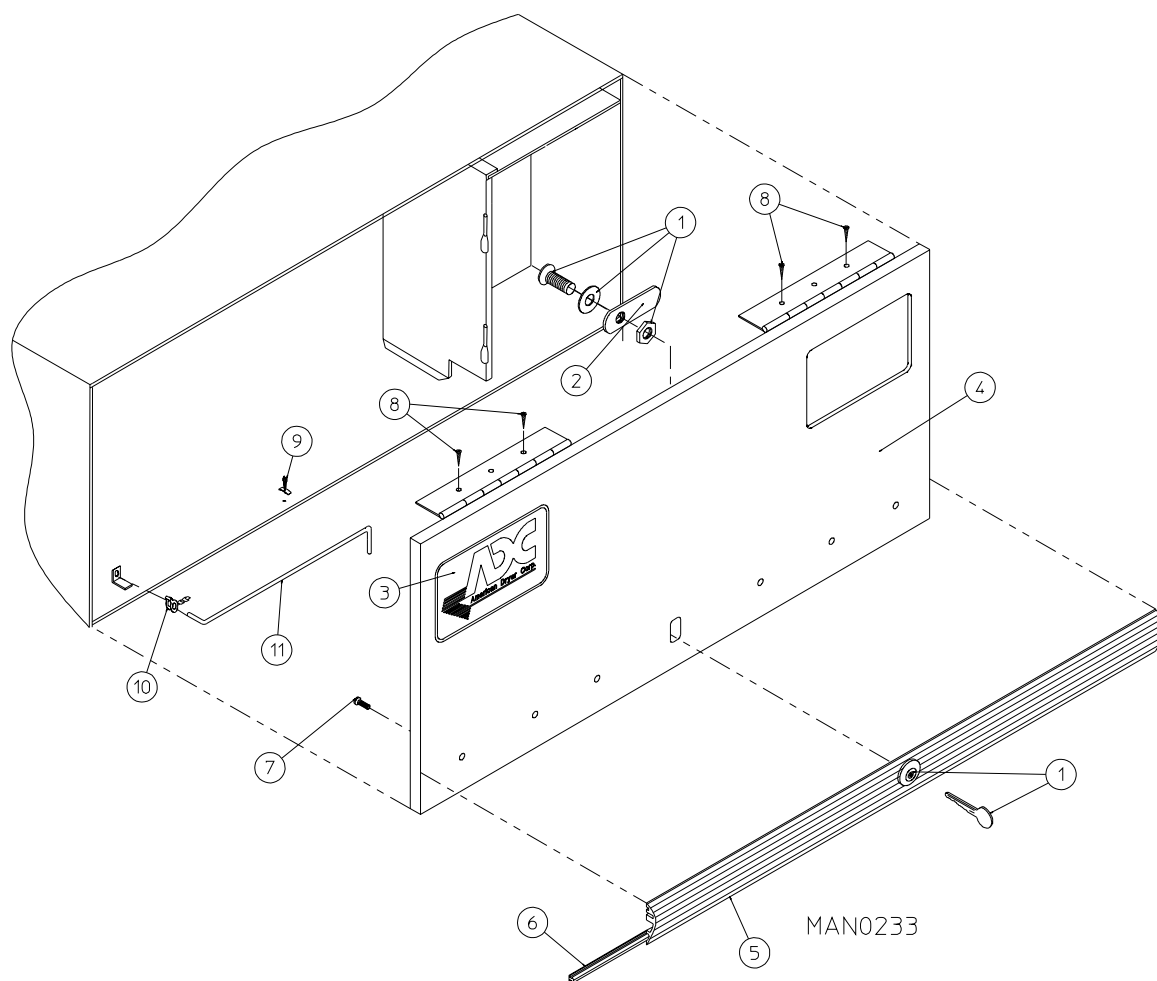

Illus. No.	Part No.	Qty.	Description
1	160017	1	Special Dummy Lock ONLY (without cam)
	160104	1	MK-100 Key ONLY (for dummy lock)
2	160016	1	Lock Cam ONLY
3	882052	1	Metal ADC Logo with Tape
	870011	1	Logo Double Sided Tape Kit
4	800020*	1	High Security Control Door Assembly (includes illus. nos. 4 through 7)
	800144	1	Stainless Steel High Security Control Door Assembly (includes illus. nos. 4 through 7)
5	180202	1	Top Trim Strip (gray) with Lock Hole (38-1/4" length)
6	117603	3	Noise Suppressor Tape (sold by the foot)
7	150201	6	#10-32 x 1/4" Phillips Round Head Machine Screw
8	150309	4	#10-32 x 1/2" Hex Head TEK Crimptite Screw
9	102600	1	Control Door Rod Support Catch
10	102601	1	Control Door Rod Retainer Clip
11	102502	1	Control Door Support Rod

* Specify color when ordering.

Phase 4 Non-Coin Microprocessor Control Panel Assembly

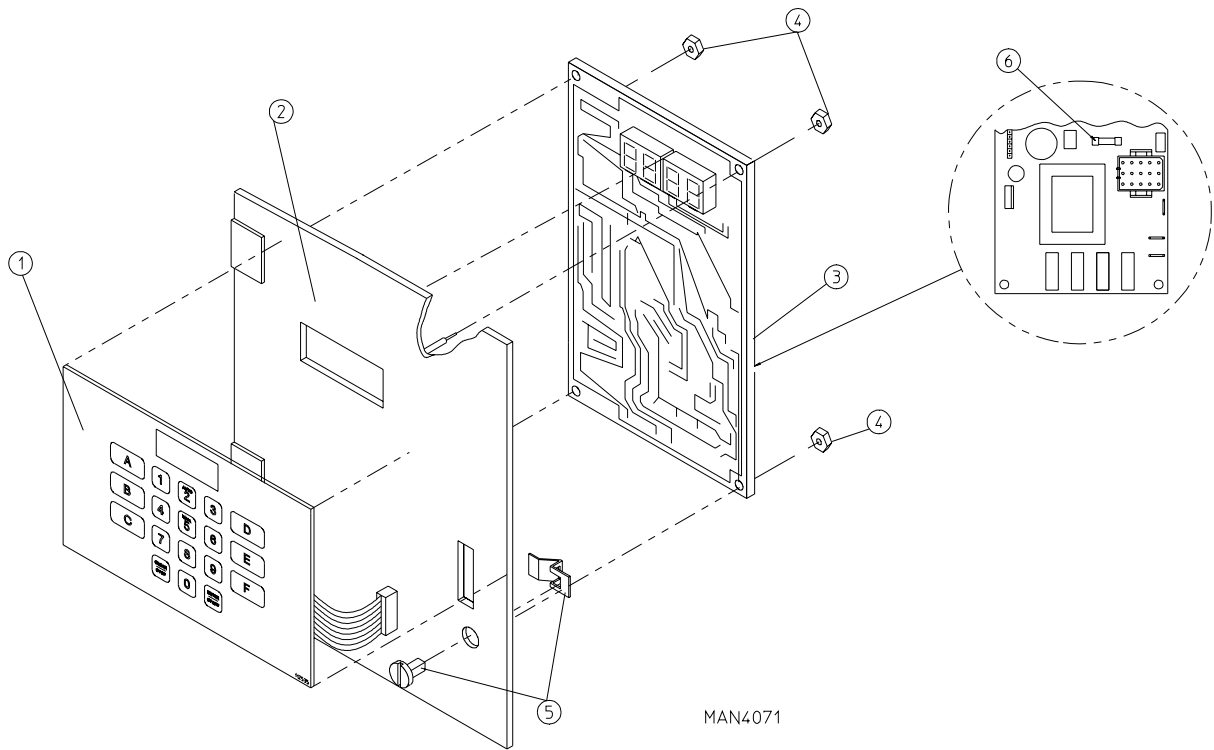

Illus. No.	Part No.	Qty.	Description
1	112535	1	Non-Coin English Keypad Label Assembly
	112276	1	Non-Coin Stick-On Labels (English Only) ... Not Illustrated
	112275	1	Non-Coin Stick-On Labels (Spanish, Italian, and Hebrew) ... Not Illustrated
	112277	1	3-Language Non-Coin Stick-On Labels (English, Spanish, and Hebrew) ... Not Illustrated
	112278	1	5-Language Non-Coin Stick-On Labels (Italian, Dutch, French, German, and Chinese) ... Not Illustrated
2	800057	1	Phase 4 Microprocessor Control Panel ONLY
	800164	1	Phase 4 Microprocessor Control Panel ONLY with Battery Bracket
	800171	1	Phase 4 Non-Coin Non-Reversing Microprocessor Control Panel Assembly Complete (includes illus. nos. 1 through 6)
	865095	1	Phase 4 Non-Coin Non-Reversing Microprocessor Control Panel Assembly Complete with Battery Option (includes illus. nos. 1 through 6)
	865092	1	Phase 4 Non-Coin Reversing Microprocessor Control Panel Assembly Complete (includes illus. nos. 1 through 6)
3	865096	1	Phase 4 Non-Coin Non-Reversing Microprocessor Control Panel Assembly Complete with Battery Option (includes illus. nos. 1 through 6)
	137125	1	Phase 4 Non-Coin Non-Reversing Microprocessor Controller (computer) ONLY
	137126	1	Phase 4 Non-Coin Non-Reversing Microprocessor Controller (computer) ONLY with Battery Clip
	137127	1	Phase 4 Non-Coin Reversing Microprocessor Controller (computer) ONLY
4	137128	1	Phase 4 Non-Coin Reversing Microprocessor Controller (computer) ONLY with Battery Clip
	152001	4	#8-32 Hex Nut
5	882541	1	Spring Turn Latch (2-piece)
6	136048	1	1/8-Amp (Slo-Blo) Fuse

IMPORTANT: Check label on computer chip to verify correct part number for microprocessor (computer).

Phase 4 Non-Coin Microprocessor Control Box Assembly

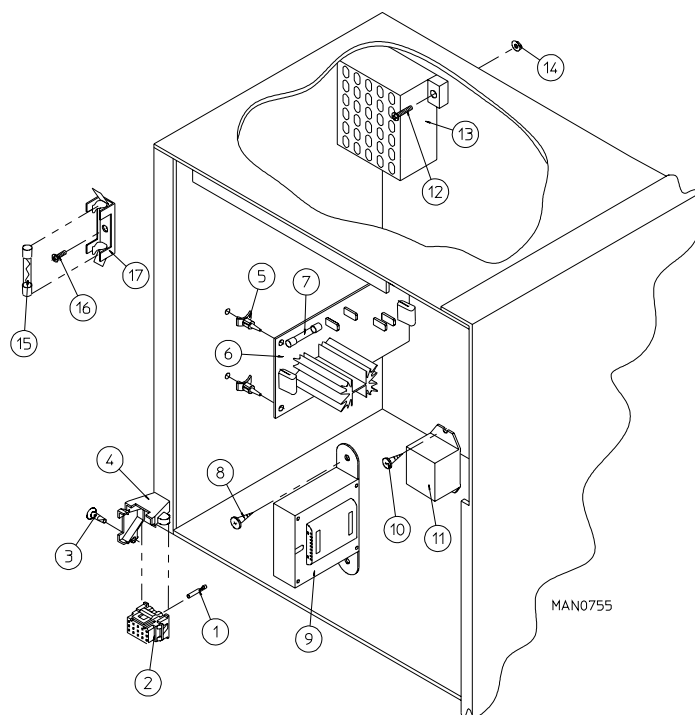

Illus. No.	Part No.	Qty.	Description
1	137021	12	Microprocessor Socket ONLY
2	137020	1	15-Pin Microprocessor Connector ONLY
	122800	1	Microprocessor (female) Pin Extraction Tool
3	150315	1	#6 x 1" Phillips Pan Head Machine Screw
4	137022	1	15-Pin Stain Relief
5	137013	4	Nylon Standoff
6	137151	1	Solid State Relay Board ONLY (1 hp 125-250v / 1 ϕ / 50/60 Hz)
	137076	1	Arc Suppressor Board with Relay (120 Volt controls)
	137078	1	Arc Suppressor Board with Relay (208/230 Volt controls)
	137061	1	Arc Suppressor Board without Relay
7*	136057	**	1/2-Amp (Slo-Blo) Fuse ONLY
	136052	**	4-Amp Fuse ONLY
8	150300	2	#10 x 1/2" Hex Washer TEK Screw
9	141403	1	Direct Spark Ignition 24 VAC Transformer (for gas models with direct spark ignition and steam models with air-operated steam damper system)
10	150309	2	#10-32 x 1/2" Hex Head TEK Crimptite Screw
11	131030	1	Steam Valve Relay – 120 Volt (for high pressure steam models and air-operated steam damper system models)
	131031	1	Steam Valve Relay – 208/230 Volt (for high pressure steam models and air-operated steam damper system models)
12	150002	2	#6-32 x 1" Phillips Round Head Machine Screw
13	120715	1	30-Position Terminal Block (for models mfd. as of March 28, 1988)
	120709	1	8-Position Terminal Strip (for models mfd. prior to March 28, 1988)
14	151000	2	#6-32 Pal Nut
15	136057	1 or 2	1/2-Amp (Slo-Blo) Fuse ONLY
16	150301	1 or 2	#8-18 x 7/16" Phillips Pan Head TEK Screw
17	136008	1 or 2	Fuse Block / Strip ONLY

* Check fuse rating for verification.

** As required.

Phase 3 Non-Coin Microprocessor Control Panel Assembly

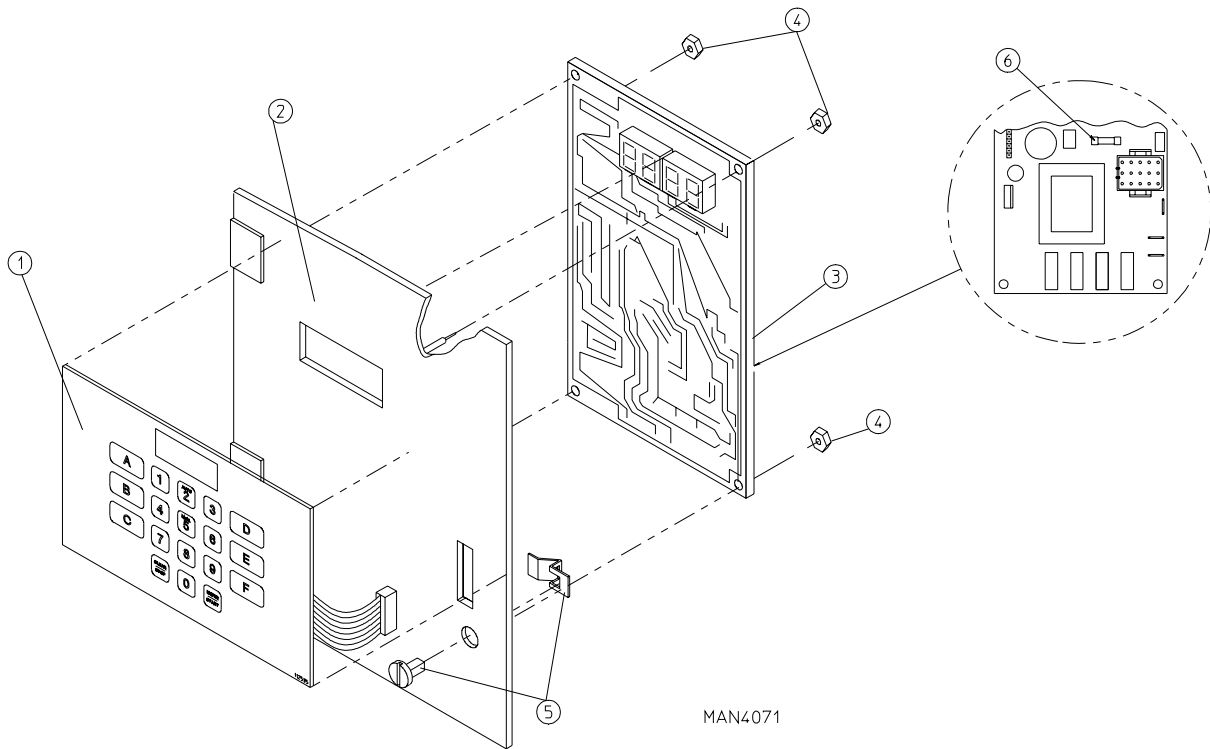

<u>Illus. No.</u>	<u>Part No.</u>	<u>Qty.</u>	<u>Description</u>
1	112535	1	Non-Coin English Keypad Label Assembly
	112276	1	Non-Coin Stick-On Labels (English Only) ... Not Illustrated
	112275	1	Non-Coin Stick-On Labels (Spanish, Italian, and Hebrew) ... Not Illustrated
	112277	1	3-Language Non-Coin Stick-On Labels (English, Spanish, and Hebrew) ... Not Illustrated
	112278	1	5-Language Non-Coin Stick-On Labels (Italian, Dutch, French, German, and Chinese) ... Not Illustrated
2	800057	1	Phase 3 Microprocessor Control Panel ONLY
	800164	1	Phase 3 Microprocessor Control Panel ONLY with Battery Bracket
	800161	1	Phase 3 Non-Coin Non-Reversing Microprocessor Control Panel Assembly Complete (includes illus. nos. 1 through 6)
	800163	1	Phase 3 Non-Coin Non-Reversing Microprocessor Control Panel Assembly Complete with Battery Option (includes illus. nos. 1 through 6)
	865088	1	Phase 3 Non-Coin Reversing Microprocessor Control Panel Assembly Complete (includes illus. nos. 1 through 6)
3	865089	1	Phase 3 Non-Coin Non-Reversing Microprocessor Control Panel Assembly Complete with Battery Option (includes illus. nos. 1 through 6)
	137092	1	Phase 3 Non-Coin Non-Reversing Microprocessor Controller (computer) ONLY
	137093	1	Phase 3 Non-Coin Non-Reversing Microprocessor Controller (computer) ONLY with Battery Clip
	137094	1	Phase 3 Non-Coin Reversing Microprocessor Controller (computer) ONLY
	137095	1	Phase 3 Non-Coin Reversing Microprocessor Controller (computer) ONLY with Battery Clip
4	152001	4	#8-32 Hex Nut
5	882541	1	Spring Turn Latch (2-piece)
6	136048	1	1/8-Amp (Slo-Blo) Fuse

IMPORTANT: Check label on computer chip to verify correct part number for controller.

Phase 3 Non-Coin Microprocessor Control Box Assembly

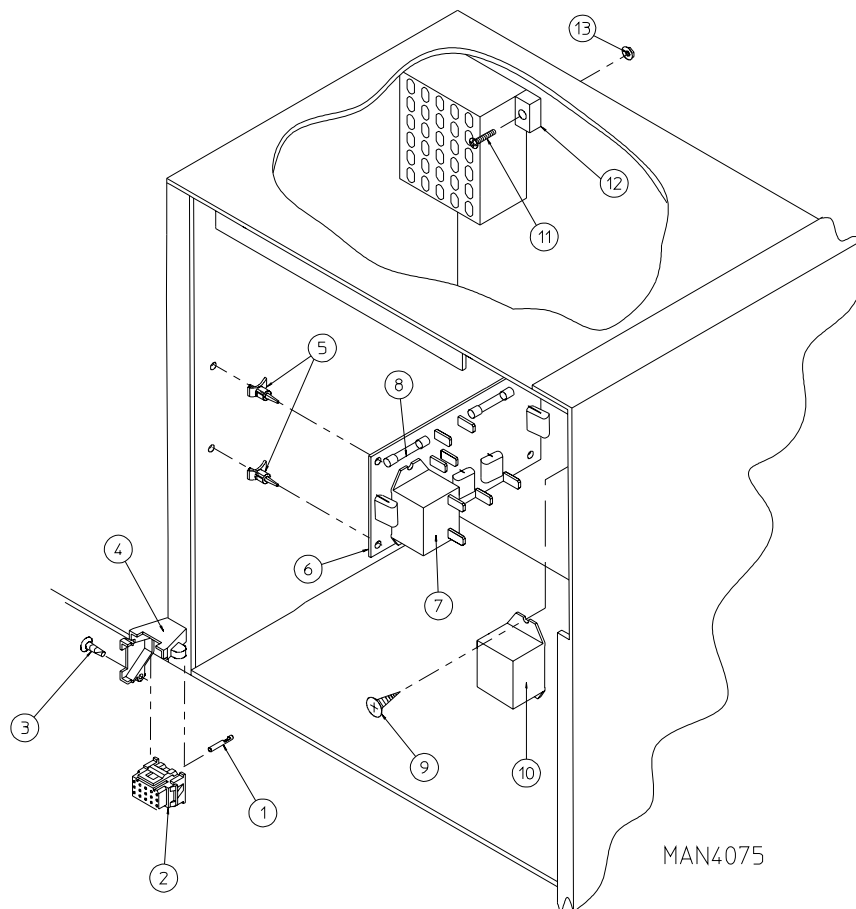

<u>Illus. No.</u>	<u>Part No.</u>	<u>Qty.</u>	<u>Description</u>
1	137021	15	Microprocessor Socket ONLY
2	137020	1	15-Pin Microprocessor Connector ONLY
	122800	1	Microprocessor (female) Pin Extraction Tool
3	150315	1	#6 x 1" Phillips Pan Head Machine Screw
4	137022	1	15-Pin Stain Relief
5	137013	4	Nylon Standoff
6	137151	1	Solid State Relay Board ONLY (1 hp 125-250v / 1 ϕ / 50/60 Hz)
	137076	1	Arc Suppressor Board with Relay (120 Volt controls)
	137078	1	Arc Suppressor Board with Relay (208/230 Volt controls)
	137061	1	Arc Suppressor Board without Relay
7	131916	1	P.C.B. (electromechanical) Relay (120 Volt controls)
	131930	2	P.C.B. (electromechanical) Relay (208/230 Volt controls)
8	136052	2	4-Amp Fuse ONLY
9	150309	2	#10-32 x 1/2" Hex Head TEK Crimptite Screw
10	131030	1	Steam Valve Relay – 120 Volt (for high pressure steam models Only)
	131031	1	Steam Valve Relay – 208/230 Volt (for high pressure steam models Only)
11	150002	2	#6-32 x 1" Phillips Round Head Machine Screw
12	120715	1	30-Position Terminal Block (for models mfd. as of March 28, 1988)
	120709	1	8-Position Terminal Strip (for models mfd. prior to March 28, 1988)
13	151000	2	#6-32 Pal Nut

Dual Timer Control Panel Assembly

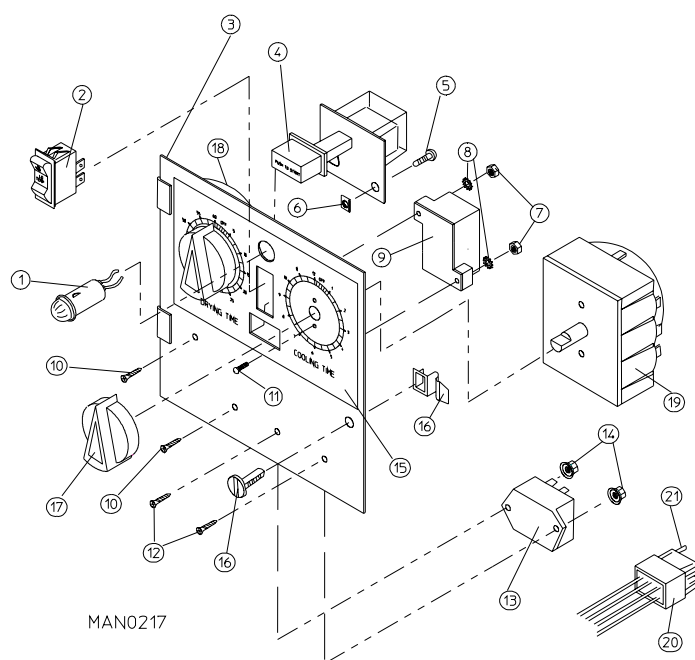

Illus. No.	Part No.	Qty.	Description
1	123000	1	Red Indicator Light – 120 Volt
	123001	1	Red Indicator Light – 230 Volt
2	122400	1	Rocker Heat Selector Switch
3	865550	1	Dual Timer Control Panel Assembly Complete – 120 Volt (includes illus. nos. 1 through 21)
	865551	1	Dual Timer Control Panel Assembly Complete – 230 Volt (includes illus. nos. 1 through 21)
4	800051	1	Dual Timer Control Panel ONLY
	131812	1	Push-to-Start Relay – 120 Volt
	131813	1	Push-to-Start Relay – 230 Volt
5	150207	2	#10-24 x 1/2" Phillips Round Head Machine Screw
6	154001	2	#10-24 Speed Nut
7	152000	2	#6-32 Hex Nut
8	153010	2	#6 Star Washer
9	120713	1	18-Position Terminal Block (for models mfd. as of May 3, 1989)
	120708	1	3-Position Terminal Block (for models mfd. prior to May 3, 1989)
10	150002	2	#6-32 x 1" Phillips Round Head Machine Screw
11	150110	4	#8-32 x 1/4" Phillips Round Head Machine Screw
12	150001	2	#6-32 x 1/2" Phillips Round Head Machine Screw
13	131030	1	Dual Timer Relay – 120 Volt
	131031	1	Dual Timer Relay – 230 Volt
14	151000	2	#6-32 Pal Nut
15	112050	1	"Dual Timer" Label ONLY
16	882541	1	Spring Turn Latch (2-piece)
17	124103	2	Arrow Timer Knob
18	124020	1	60-Minute Timer – 120 Volt
	124021	1	60-Minute Timer – 230 Volt
19	124022	1	15-Minute Timer – 120 Volt
	124023	1	15-Minute Timer – 230 Volt
20	122602	1	9-Pin Connector ONLY
21	122700	8	Pin Terminal ONLY
—	122801	1	Pin / Socket Extraction Tool

Dual Timer Control Box Assembly

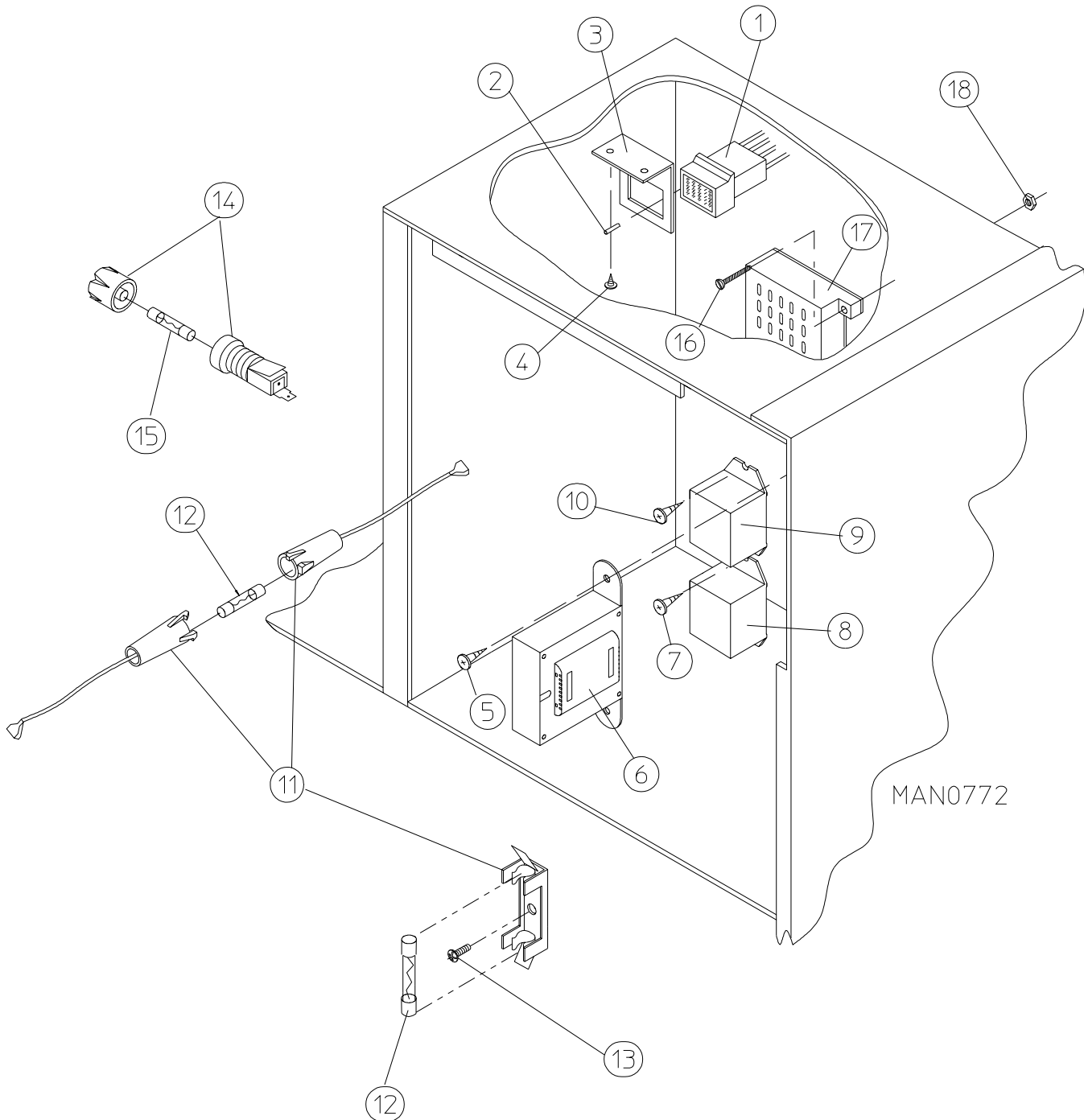

Dual Timer Control Box Assembly

<u>Illus. No.</u>	<u>Part No.</u>	<u>Qty.</u>	<u>Description</u>
1	122603	1	9-Pin Socket Connector
2	122701	8	Socket Terminal ONLY
	122801	1	Pin / Socket Extraction Tool
3	315010	1	9-Pin Connector Bracket
4	150300	2	#10 x 1/2" Hex Washer TEK Screw
5	150300	2	#10 x 1/2" Hex Washer TEK Screw
6	141403	1	Direct Spark Ignition 24 VAC Transformer (for gas models with direct spark ignition and steam models with air-operated steam damper system)
7	150309	2	#10-32 x 1/2" Hex Head TEK Crimptite Screw
8	131030	1	Steam Valve Relay – 120 Volt (for high pressure steam models and air-operated steam damper system models)
	131031	1	Steam Valve Relay – 208/230 Volt (for high pressure steam models and air-operated steam damper system models)
9	131814	1	Motor Control Relay (120 Volt controls)
	131815	1	Motor Control Relay (208/230 Volt controls)
10	150309	2	#10-32 x 1/2" Hex Head TEK Crimptite Screw
11	136008	*	Fuse Block / Strip ONLY
12**	136057	*	1/2-Amp (Slo-Bl) Fuse ONLY
	136052	*	4-Amp (Slo-Bl) Fuse ONLY
	136054	*	15-Amp (Slo-Bl) Fuse ONLY
	136056	*	20-Amp (Slo-Bl) Fuse ONLY
	136058	*	25-Amp (Slo-Bl) Fuse ONLY
13	150301	*	#8-18 x 7/16" Phillips Pan Head TEK Screw
14	136002	*	Panel Mount Fuse Holder Assembly
15**	136052	*	4-Amp (Slo-Bl) Fuse ONLY
	136054	*	15-Amp (Slo-Bl) Fuse ONLY
	136056	*	20-Amp (Slo-Bl) Fuse ONLY
	136058	*	25-Amp (Slo-Bl) Fuse ONLY
16	150002	2	#6-32 x 1" Slotted Round Head Machine Screw
17	120715	1	30-Position Terminal Block (for models mfd. as of March 28, 1988)
	120709	1	8-Position Terminal Strip (for models mfd. prior to March 28, 1988)
18	151000	2	#6-32 Pal Nut

* As required.

** Check fuse rating for verification.

Front Panel Assembly

Latch Type

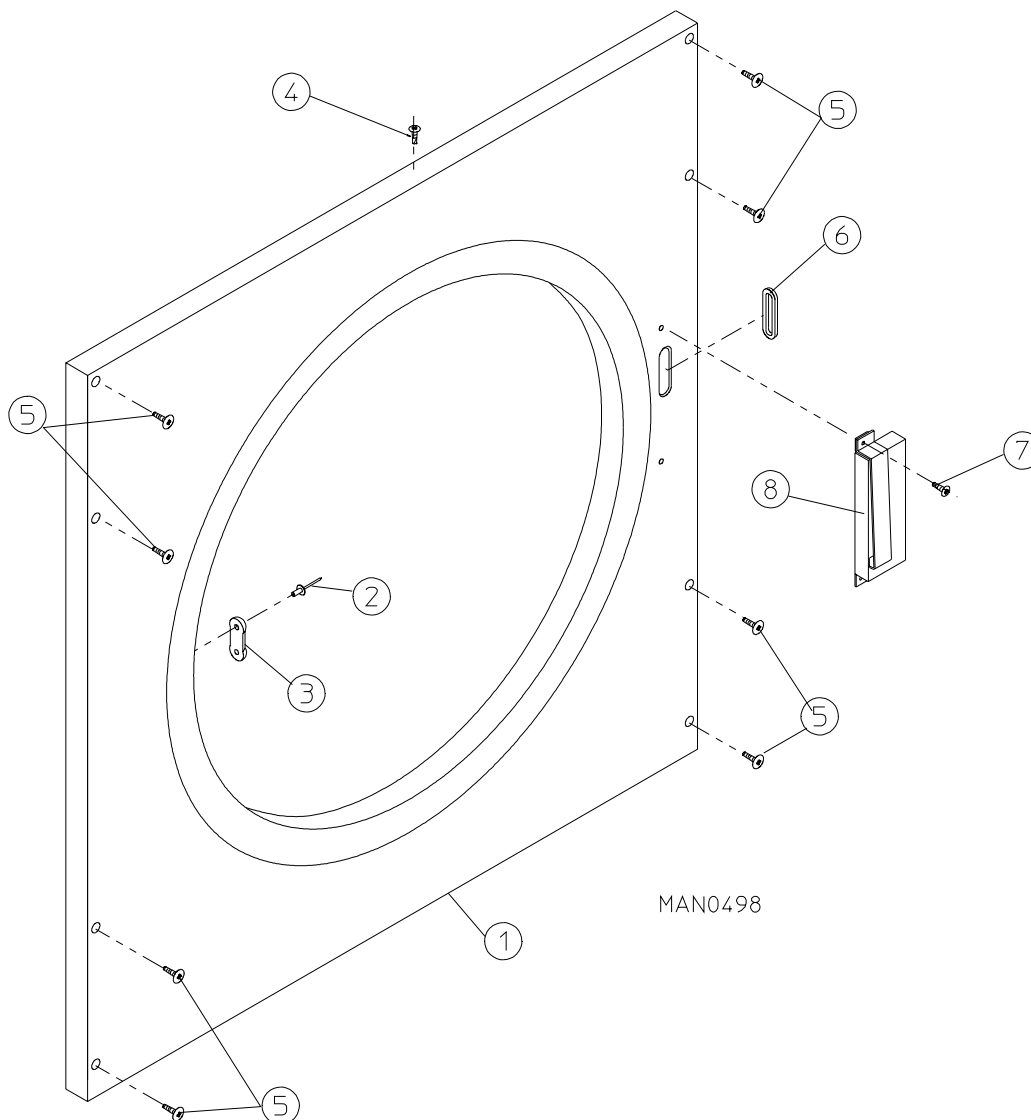

Illus. No.	Part No.	Qty.	Description
1	875302*	1	Right Hand Insulated Front Panel Assembly (latch type) Complete (includes illus. nos. 1, 2, 3, and 6)
	875313	1	Right Hand Stainless Steel Insulated Front Panel Assembly (latch type) Complete (includes illus. nos. 1, 2, 3, and 6)
2	154215	2	5/32" Pop Rivet
3	170330	1	Friction Door Latch
4	150300	1	#10 x 1/2" Hex Washer TEK Screw
5	150309	8	#10-32 x 1/2" Hex Head TEK Crimpite Screw
6	121405	1	Rubber Grommet
7	150201	2	#10-32 x 1/4" Phillips Pan Head TEK Screw
8	—	1	N.S. Series Door Switch (for microprocessor [computer] models mfd. as of November 21, 1990 and non-microprocessor models mfd. as of November 15, 1990) Refer to Main Door Switch Assembly – N.S. Series on page 16

* Specify color when ordering.

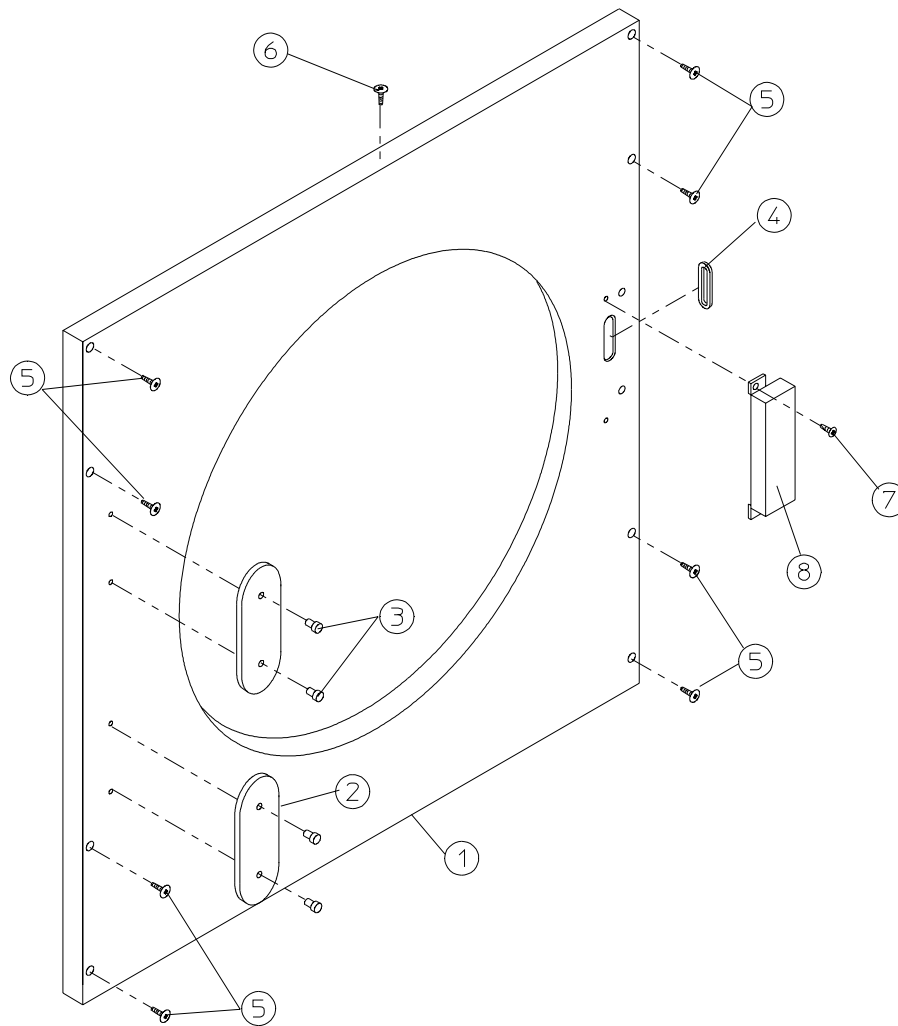

MAN0499

Illus. No.	Part No.	Qty.	Description
1	800367*	1	Right Hand Front Panel Assembly (magnet type) Complete with Hinge (includes illus. nos. 1, 2, 3, and 6)
	800373*	1	Right Hand Insulated Front Panel Assembly (magnet type) Complete with Hinge (includes illus. nos. 1, 2, 3, and 6)
	800387	1	Right Hand Stainless Steel Insulated Front Panel Assembly (magnet type) Complete with Hinge (includes illus. nos. 1, 2, 3, and 6)
2	170340	2	3-1/2" Stainless Steel Striker Pad
3	154215	4	5/32" Pop Rivet
4	121405	1	Rubber Grommet
5	150309	8	#10-32 x 1/2" Hex Head TEK Crimplite Screw
6	150300	1	#10 x 1/2" Hex Washer TEK Screw
7	150201	2	#10-32 x 1/4" Phillips Pan Head TEK Screw
8	—	1	N.S. Series Door Switch (for microprocessor [computer] models mfd. prior to November 21, 1990 and non-microprocessor models mfd. prior to November 15, 1990) Refer to Main Door Switch Assembly – Plunger Type on page 17

* Specify color when ordering.

Main Door Assembly

Latch Type

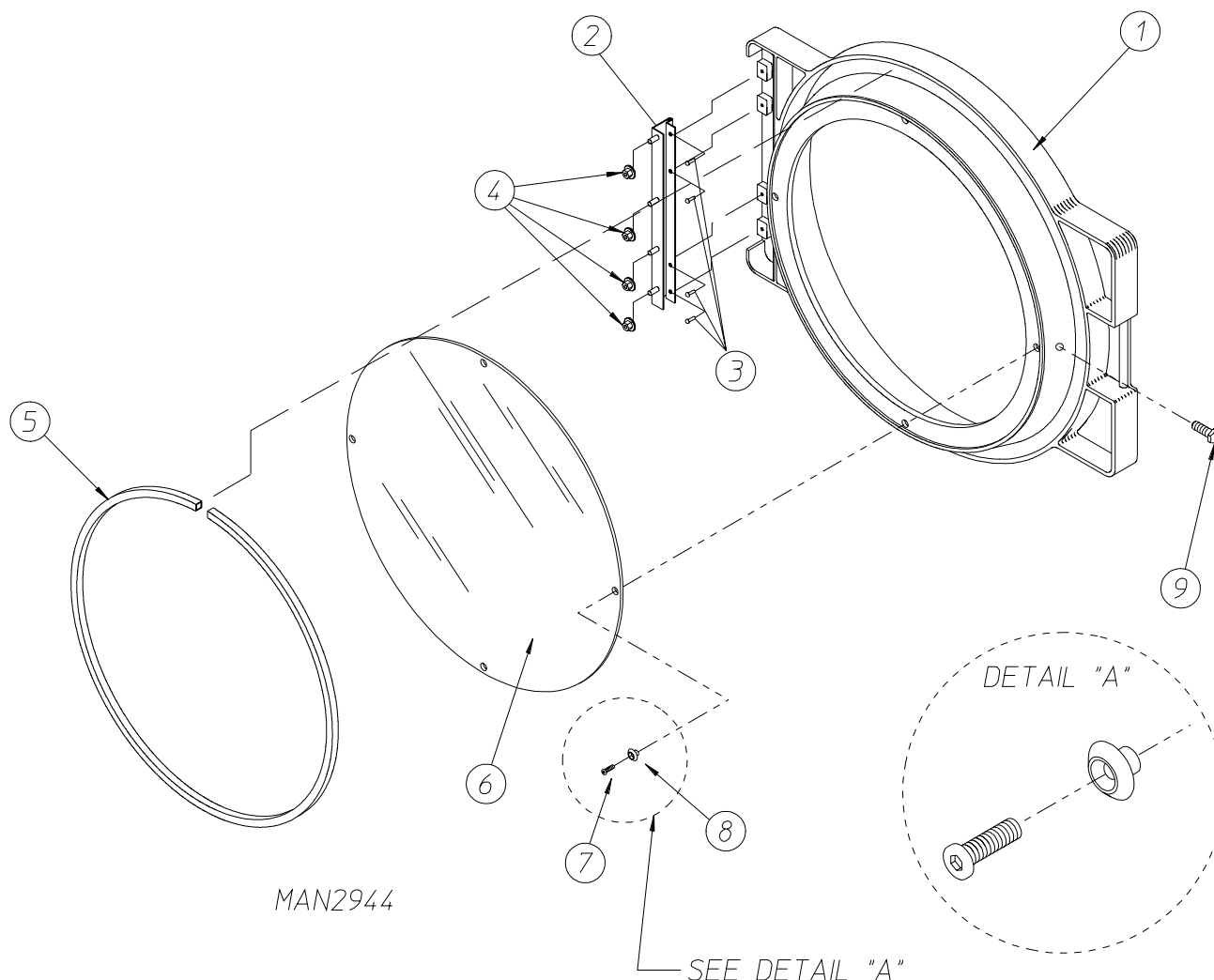

Illus. No.	Part No.	Qty.	Description
1*	881421	1	Gray Plastic Main Door Assembly (latch type) Complete with Mechanical Fasteners (includes illus. nos. 1 and 5 through 9)
2	800448	1	12-1/2" Stainless Steel Main Door Hinge Assembly
3	150410	4	#10-24 x 3/8" Phillips Pan Head Crimptite Screw
4	152014	4	1/4-20 Free Spin Wash Nut
5	102349	1	Main Door Gasket
6	102212	1	20-7/16" Door Glass with 4 Holes
	170730	1	Main Door Gasket / Glass Adhesive (10.3 oz. cartridge)
7	170319	4	1/2" Stainless Steel Flat Head Allen Screw
8	150448	4	Door Glass (nylon) Spacer
9	150431	1	Main Door Latch Screw (#10 x 7/16" dome hex head screw)

* Contact factory for color other than gray.

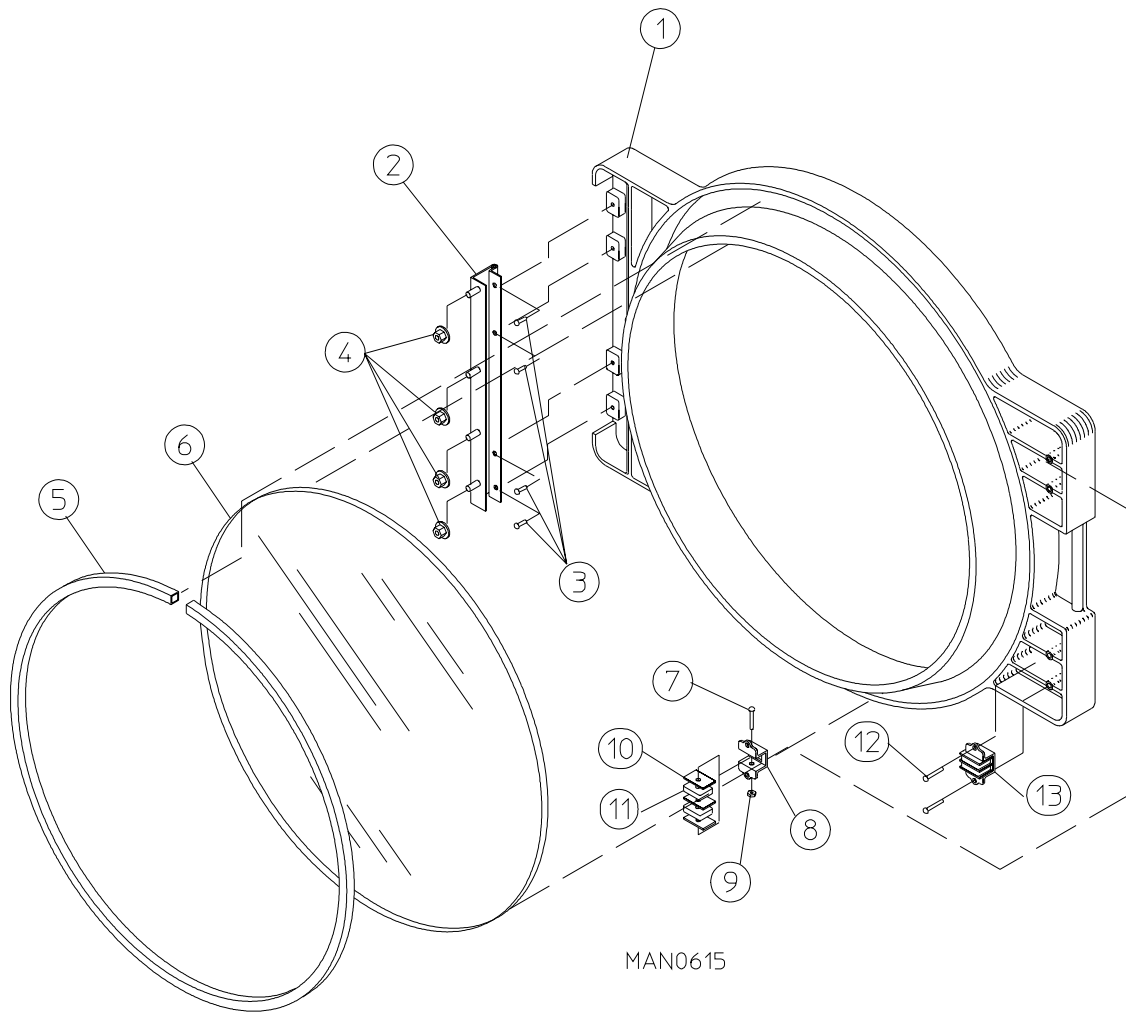

Illus. No.	Part No.	Qty.	Description
1*	800136**	1	Gray Plastic Main Door Assembly Complete with Mechanical Fasteners (includes illus. nos. 1 through 13)
2	103050	4	12-1/2" Stainless Steel Main Door Hinge Assembly
3	150410	4	#10-24 x 3/8" Phillips Pan Head Taptite Screw
4	152014	1	1/4-20 Free Spin Wash Nut
5	102349	1	Main Door Gasket
6	102210	1	20-7/16" Door Glass
	170730	1	Main Door Gasket / Glass Adhesive (10.3 oz. cartridge)
7	150002	2	#6-32 x 1" Phillips Round Head Machine Screw
8	102105	2	Magnet Holder ONLY
9	152013	2	#6-32 Hex Nut
10	306802	6	Magnet Keeper
11	102102	4	Door Magnet (.215)
12	150410	4	#10-24 x 3/8" Phillips Pan Head Taptite Screw
13	800131	2	Cast Aluminum Magnet Holder Assembly Complete (includes illus. nos. 7 through 11)

* All dryers mfd. as of June 1, 1989 are built with a lightweight (plastic) main door assembly.

** Contact factory for color other than gray.

Main Door Switch Assembly

N.S. Series

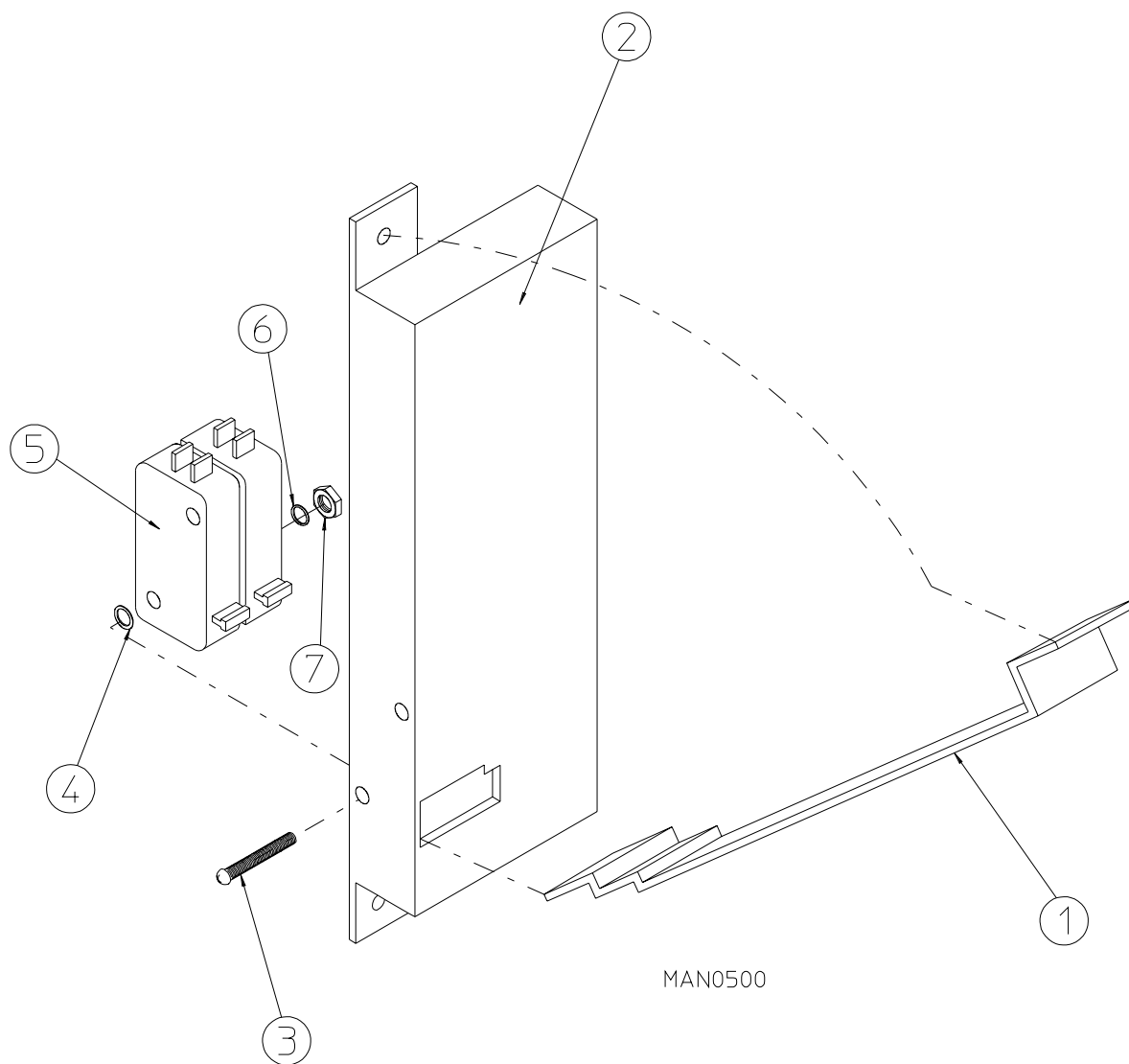

<u>Illus. No.</u>	<u>Part No.</u>	<u>Qty.</u>	<u>Description</u>
1	313215	1	Door Actuator Arm
2	800445*	1	N.S. Series Microprocessor Main Door Switch Housing Assembly Complete (for models mfd. as of November 21, 1990) (includes illus. nos. 1 through 7)
	800446**	1	N.S. Series Non-Microprocessor Main Door Switch Housing Assembly Complete (for models mfd. as of November 15, 1990) (includes illus. nos. 1 through 7)
3	150025	1	#4-40 x 1" Phillips Pan Head Machine Screw
4	153045	2	#4 Lock Washer
5	137004	***	N.S. Series Main Door Switch ONLY
6	153045	2	#4 Lock Washer
7	152016	2	#4-40 Hex Nut

* Microprocessor (computer) model dryers require 2 N.S. series main door switches.

** Non-microprocessor model dryers require 1 N.S. series main door switch.

***As required (either 1 or 2).

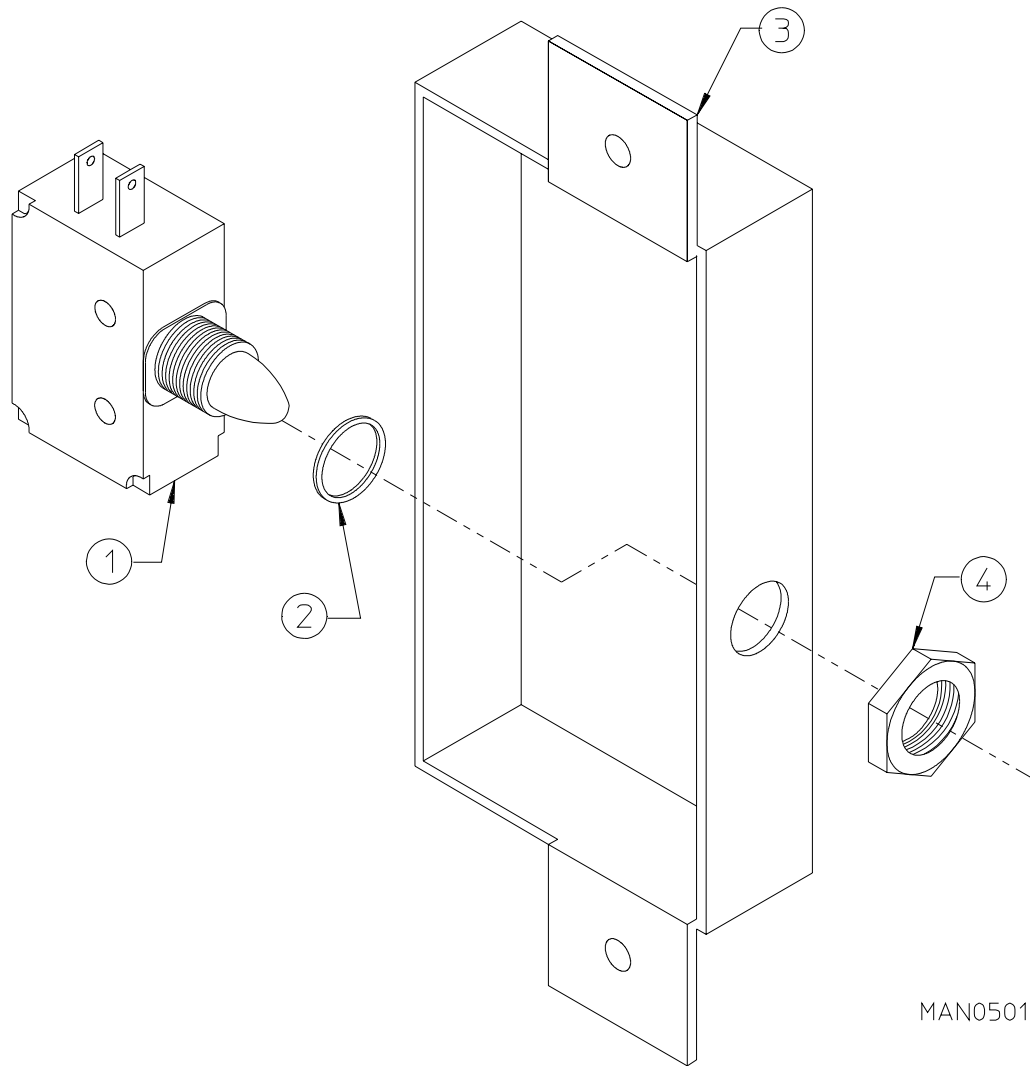

MAN0501

Illus. No.	Part No.	Qty.	Description
1	137003	1	Plunger Type Main Door Switch (includes illus. nos. 1, 2, and 4)
2	401551	*	Door Switch Spacer / Washer
3	870010	1	Plunger Type Main Door Switch Assembly Complete (for microprocessor [computer] models mfd. prior to November 21, 1990 and non-microprocessor models mfd. prior to November 15, 1990) (includes illus. nos. 1 through 4)
	313209	1	Plunger Type Main Door Switch Housing ONLY
4	152003	1	3/8-32 x 1/2" Door Switch Nut

* As required (either 1 or 2).

Lint Trap Assembly

For Steam Models with 10" Exhaust Mfd. as of October 25, 1991

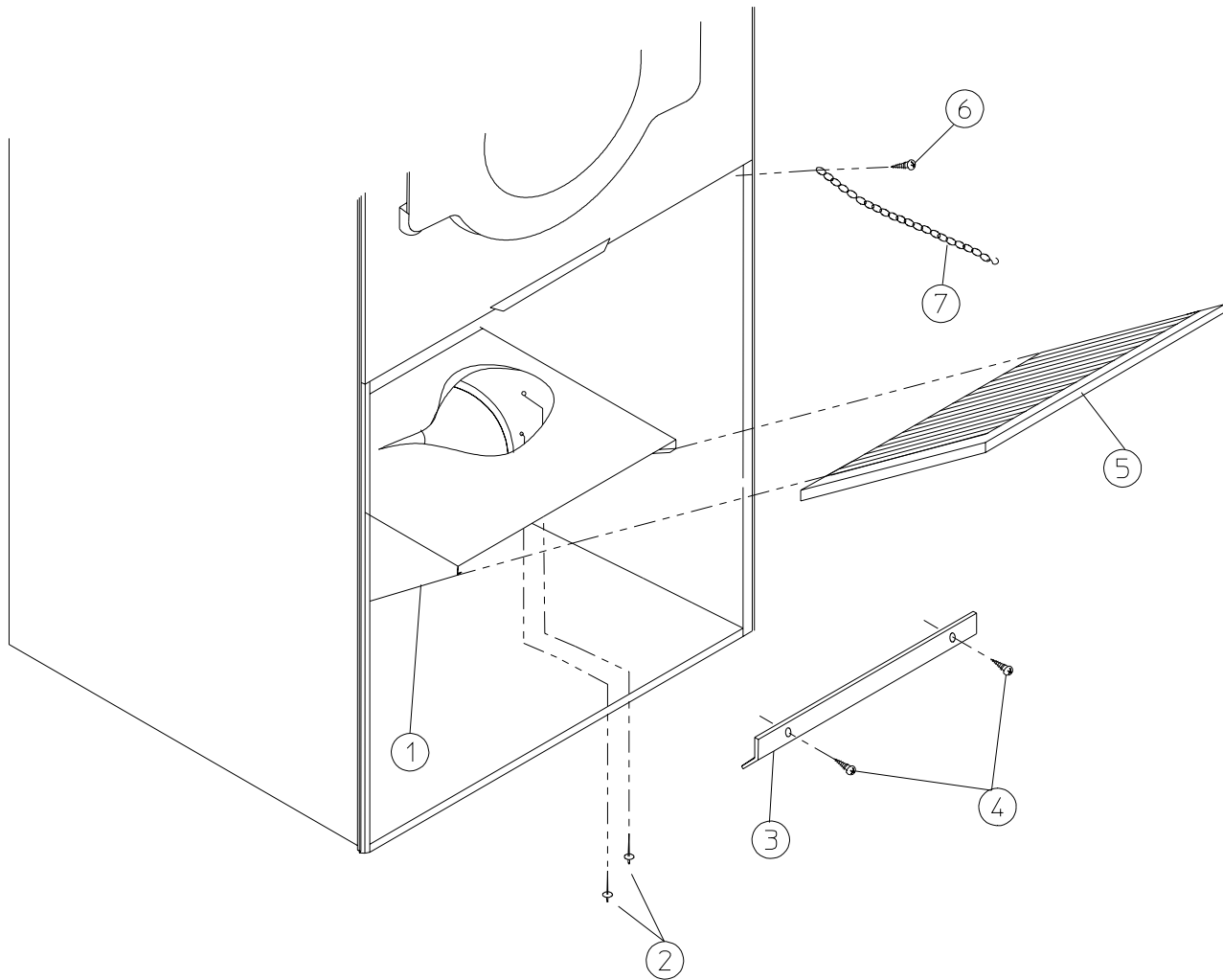

MAN0107

Illus. No.	Part No.	Qty.	Description
1	800440	1	Non-Reversing Lint Trap Assembly Complete (includes illus. nos. 1, 3, 4, and 5)
	800433	1	Non-Reversing Lint Trap ONLY
	800441	1	Reversing Lint Trap Assembly Complete (includes illus. nos. 1, 3, 4, and 5)
	800434	1	Reversing Lint Trap ONLY
2	154200	7	5/32" Pop Rivet
3	304101	1	Lint Screen Holder ONLY
4	150300	2	#10 x 1/2" Hex Washer TEK Screw
5	800506	1	Lint Screen ONLY
6	150419	2	#6 x 1/2" Tamperproof TEK Screw
7	108120	1	Chain for Drop Lint Door (10-1/2" length)
-	150418	1	Tamperproof Screw Hand Driver

For Gas and Steam Models with 8" Exhaust Mfd. prior to October 25, 1991

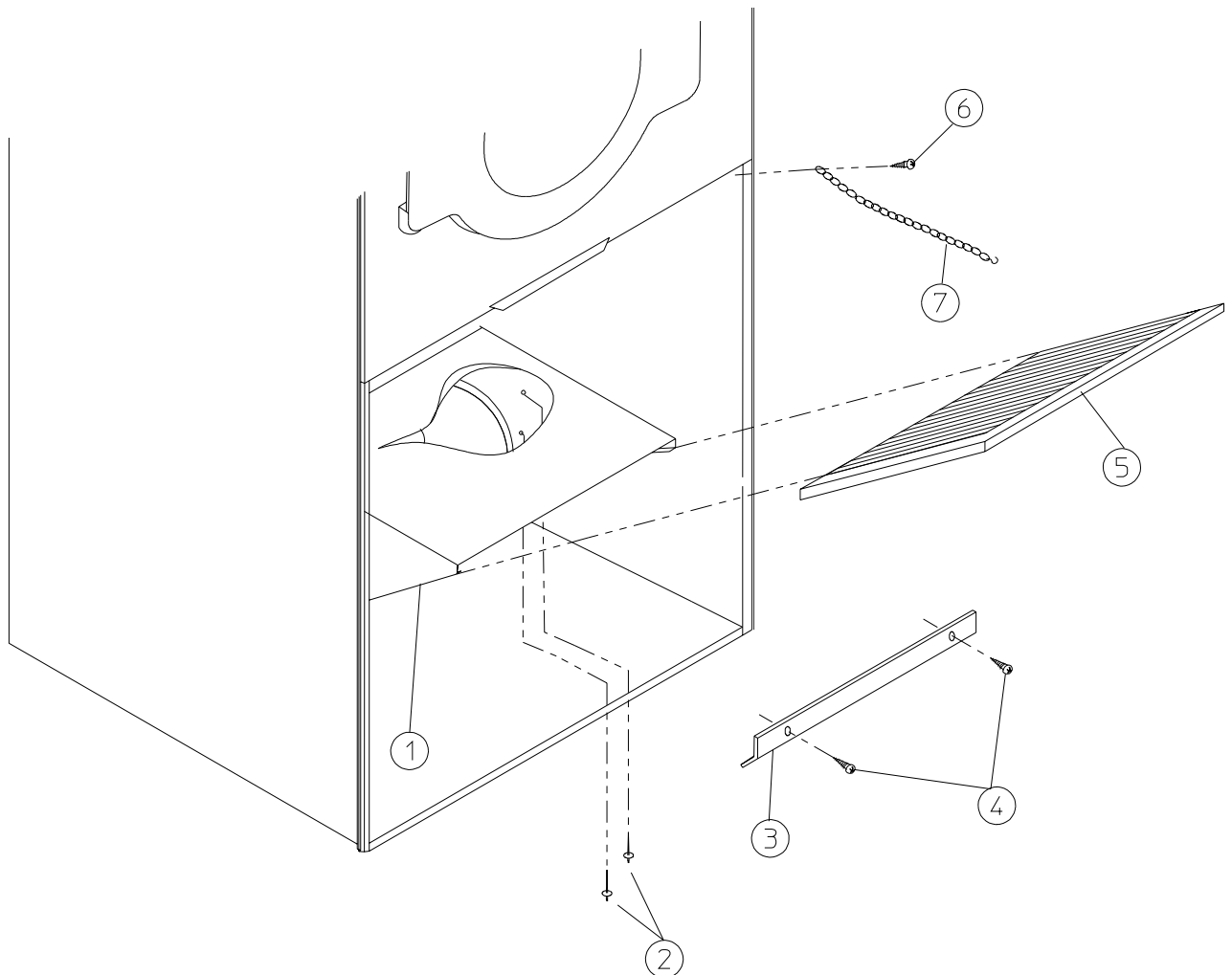

MAN0107

Illus. No.	Part No.	Qty.	Description
1	800420	1	Non-Reversing Lint Trap Assembly Complete (includes illus. nos. 1, 3, 4, and 5)
	800421	1	Non-Reversing Lint Trap ONLY
	800422	1	Reversing Lint Trap Assembly Complete (includes illus. nos. 1, 3, 4, and 5)
	800434	1	Reversing Lint Trap ONLY
2	154200	7	5/32" Pop Rivet
3	304101	1	Lint Screen Holder ONLY
4	150300	3	#10 x 1/2" Hex Washer TEK Screw
5	800506	1	Lint Screen ONLY
6	150419	2	#6 x 1/2" Tamperproof TEK Screw
7	108120	1	Chain for Drop Lint Door (10-1/2" length)
-	150418	1	Tamperproof Screw Hand Driver

Drop Lint Door Assembly

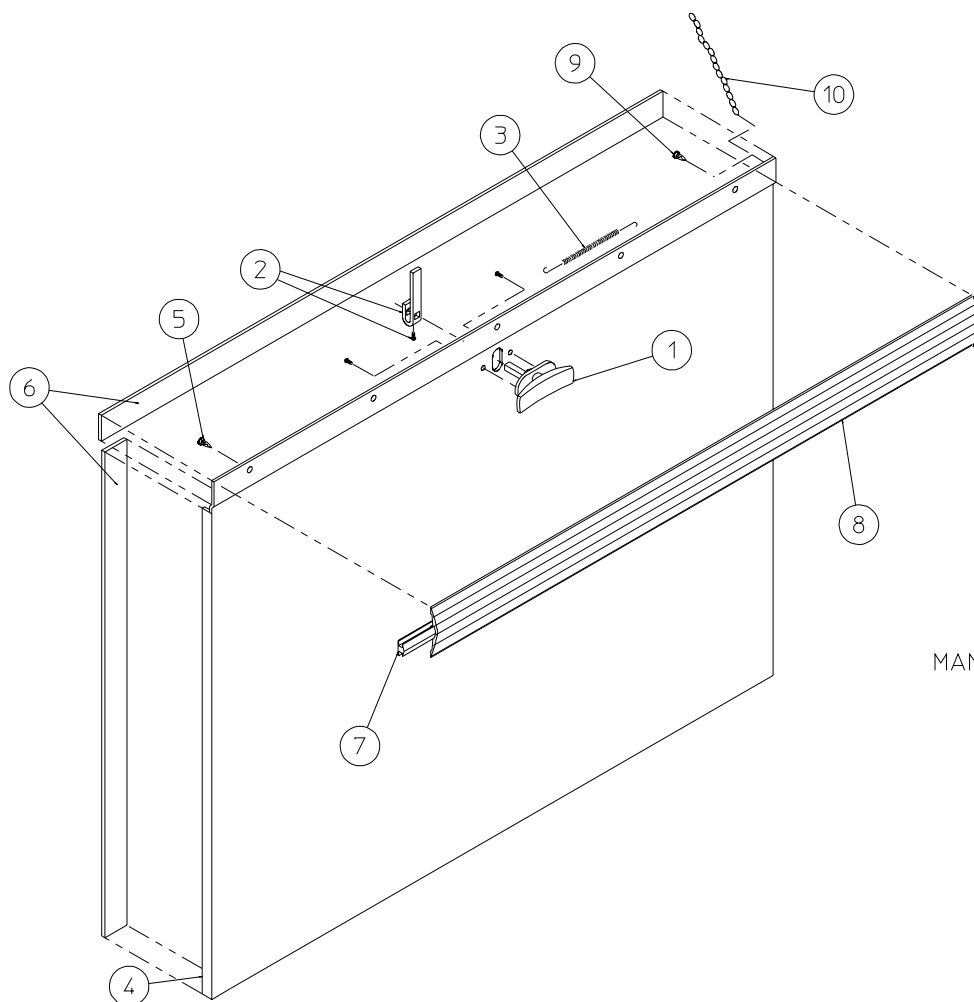

MAN0188

Illus. No.	Part No.	Qty.	Description
1	800150	1	Knob Latch Kit Assembly (includes illus. nos. 1 and 2)
	160200	1	Knob Latch ONLY with 2 Screws (without cam)
	160003	1	Dummy Lock ONLY (for non-coin models)
	160104	1	MK-100 Key ONLY (for dummy lock)
2	160009	1	Knob Latch Adjustable Cam ONLY
	150425	1	#12-24 x 3/8" Round Head Machine Screw ONLY (screw for knob latch adjustable cam)
	160008	1	Lock Cam ONLY
3	157000	1	Drop Lint Door Spring
4	800237*	1	Insulated Drop Lint Door Assembly (includes illus. nos. 4 through 8)
	880229	1	Stainless Steel Insulated Drop Lint Drawer Assembly (includes illus. nos. 4 through 8)
5	150201	6	#10-32 x 1/4" Phillips Pan Head TEK Screw
6	117604	7	Neoprene Sponge Tape (sold by the foot)
7	117603	3	Noise Suppressor Tape (sold by the foot)
8	180212	1	Gray Mid Trim / Kick Plate (8-1/4" length)
9	150419	2	#6 x 1/2" Tamperproof TEK Screw
10	108120	1	Chain for Drop Lint Door (10-1/2" length)
—	150418	1	Tamperproof Screw Hand Driver

* Specify color when ordering.

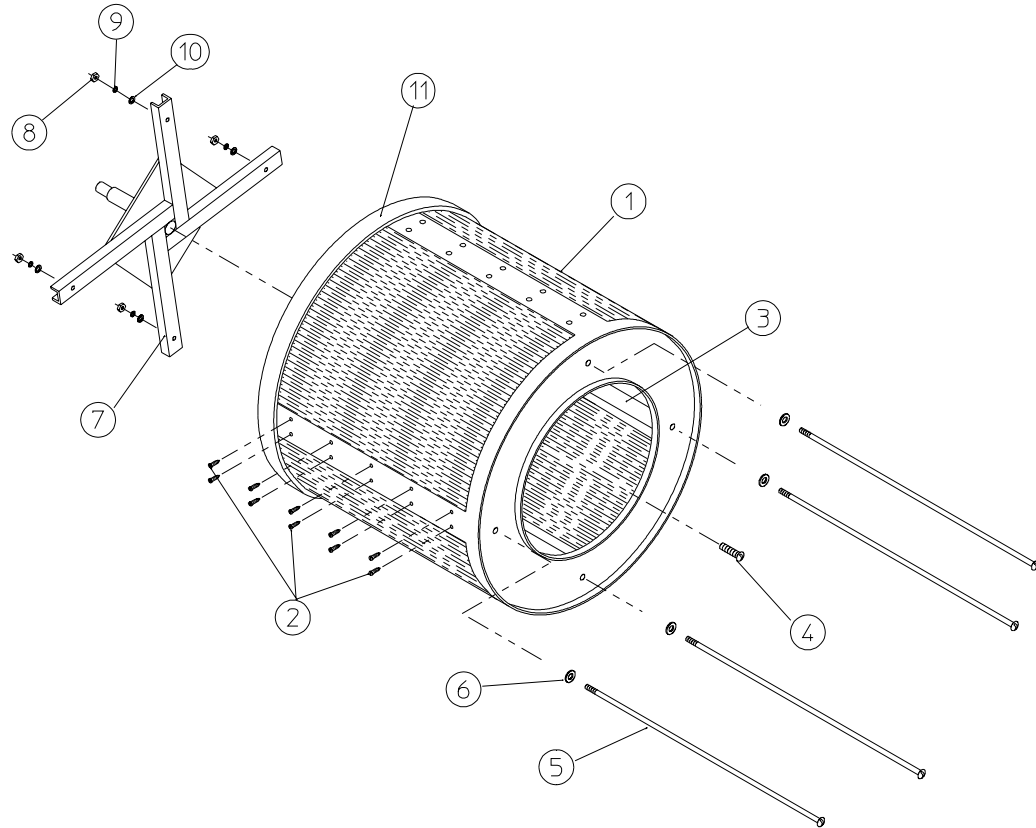

MAN0251

Illus. No.	Part No.	Qty.	Description
1	800708	1	Tumbler ONLY without Felt Collar
	800857	1	Stainless Steel Tumbler ONLY without Felt Collar
	800816*	1	1-3/4" Non-Reversing Tumbler and Support Assembly Complete (includes illus. nos. 1 through 10)
	800873*	1	1-3/4" Stainless Steel Non-Reversing Tumbler and Support Assembly Complete (includes illus. nos. 1 through 10)
	800819*	1	1-3/4" Reversing Tumbler and Support Assembly Complete (includes illus. nos. 1 through 10)
	800876*	1	1-3/4" Stainless Steel Reversing Tumbler and Support Assembly Complete (includes illus. nos. 1 through 10)
2	150413	40	#10-16 x 1/2" TORX® Head Crimpite Screw
	150429	1	TORX® Hand Driver (for removal of TORX® head screw)
3	301308	4	Tumbler Rib ONLY
	301408	4	Stainless Steel Tumbler Rib ONLY
4	150500	1	5/16-18 x 3/4" Socket Button Head Screw
5	100905	4	3/8-16 x 37" Tie Rod
6	153004	4	3/8" Flat Washer
7	800613	1	1-3/4" Non-Reversing Tumbler Support ONLY
	800615	1	1-3/4" Reversing Tumbler Support ONLY
8	152005	4	3/8" Hex Nut
9	153005	4	3/8" Lock Washer
10	153004	4	3/8" Flat Washer
11	116000	1	Felt Collar ONLY
—	401010	1	#847 Adhesive for Felt Collar

* Felt collar is not included and must be ordered separately.

Tumbler Bearing Assembly

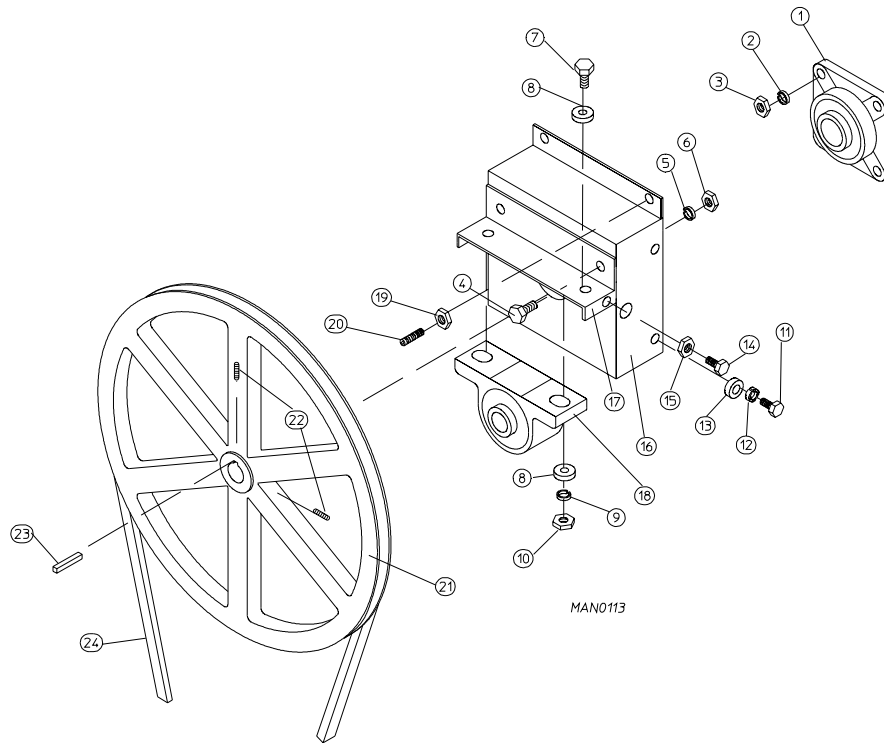

MAN0113

Illus. No.	Part No.	Qty.	Description
1	880220	1	1-3/4" Flange Bearing with Nylock Setscrew
2	153025	4	9/16" Lock Washer
3	152050	4	9/16-12 Hex Nut
4	150508	2	3/8-16 x 3/4" Hex Head Machine Bolt
5	153005	2	3/8" Lock Washer
6	152005	2	3/8-16 Hex Nut
7	150600	2	3/8-16 x 1-1/2" Hex Head Machine Bolt
8	153004	*	3/8" Flat Washer
9	153005	2	3/8" Lock Washer
10	152005	2	3/8-16 Hex Nut
11	150501	4	5/16-18 x 3/4" Hex Head Machine Bolt
12	153002	4	5/16" Lock Washer
13	153001	4	5/16" Flat Washer
14	150621	2	5/16-18 x 1-1/2" Hex Head Machine Bolt
15	152004	2	5/16-18 Hex Nut
16	801101	1	1-3/8" Bearing Box Assembly Complete for Models Mfd. without Rotational Sensor (includes illus. nos. 4 through 20)
	801103	1	1-3/8" Bearing Box and Support ONLY (includes illus. nos. 4, 5, 6, 16, and 17)
	801105	1	1-3/8" Bearing Box ONLY
17	801104	1	Pillow Block Bearing Support ONLY
18	880202	1	1-3/8" Pillow Block Bearing with Nylock Setscrew
19	152004	2	5/16-18 Hex Nut
20	150610	2	5/16-18 x 1-1/2" Allen Setscrew
21	101100	1	18" Pulley (for non-reversing models Only)
	101118	1	18-3/4" Pulley (for reversing models Only)
	101119	1	1-3/8" Taper Lock Hub (key not included) for Reversing Models ONLY
22	154301	2	5/16-18 x 5/16" Allen Setscrew
23	100713	1	1/4" x 1/4" x 7/8" Key
24	100106	1	5L-690 V-Belt (tumbler to idler)

* As required.

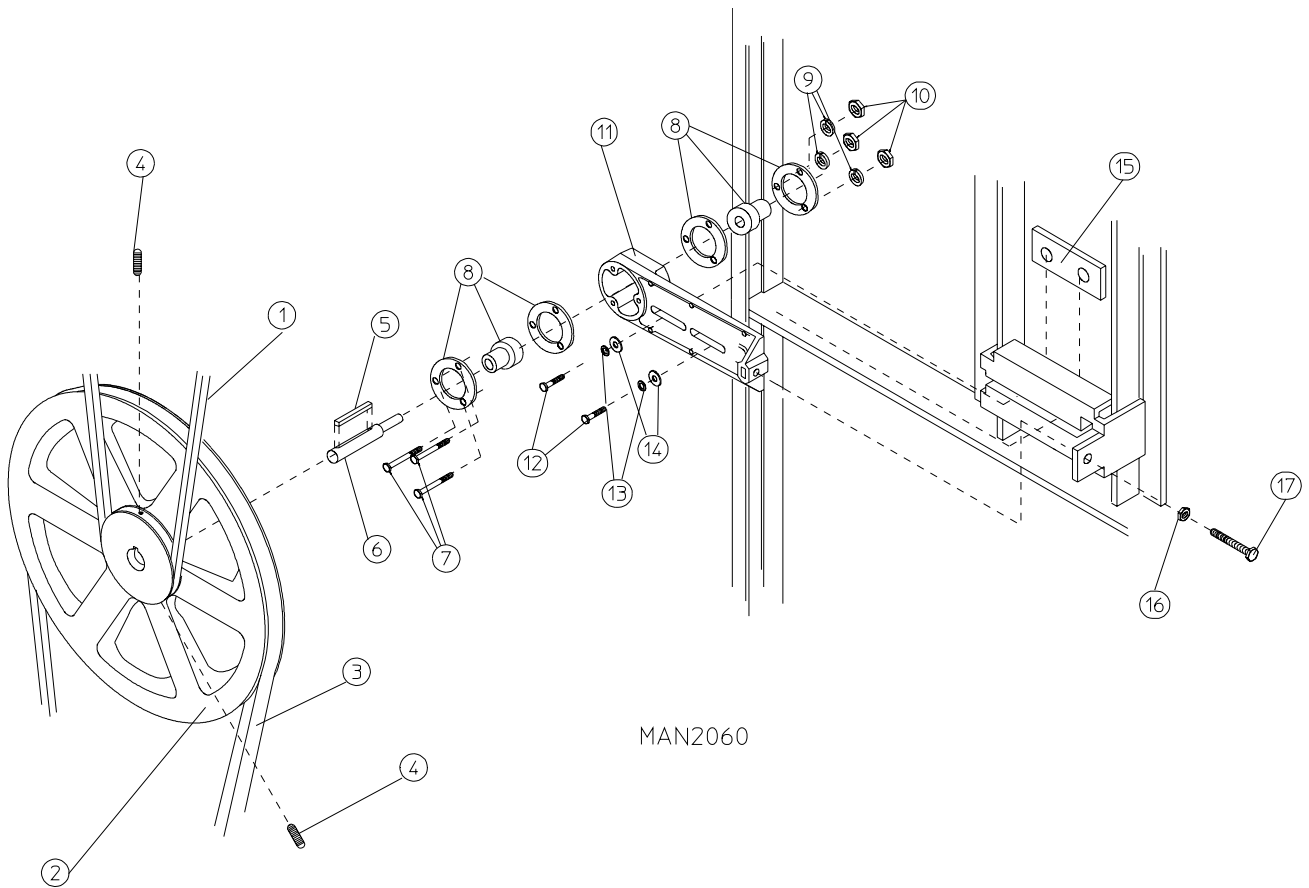

MAN2060

Illus. No.	Part No.	Qty.	Description
1	100106	1	5L-690 V-Belt (idler to tumbler)
2	101140	1	14" x 3" Compound Pulley
3	100117	1	4L-620 V-Belt (idler to motor) for Non-Reversing Models ONLY
	100114	1	4L-630 V-Belt (idler to motor) for Reversing Models ONLY
4	154301	2	5/16-18 x 1" Allen Setscrew
5	100705	1	3/16" x 3/16" x 1-3/8" Key
6	301850	1	5/8" x 3/4" Idler Shaft
7	150529	3	1/4-20 x 2-1/4" Carriage Bolt
8	880214	2	5/8" Flange Bearing with Nylock Setscrew
9	153007	3	1/4" Lock Washer
10	152002	3	1/4-20 Hex Nut
11	801007	1	Idler Bearing Assembly Complete (includes illus. nos. 5 through 17)
12	150617	2	3/8-16 x 1" Hex Head Machine Bolt
13	153005	2	3/8" Lock Washer
14	153004	2	3/8" Flat Washer
15	801009	1	Idler Square Washer
16	152004	1	5/16-18 Hex Nut
17	150509	1	5/16-18 x 3" Hex Head Machine Bolt

Non-Reversing T.E.F.C. Motor Mount Assembly

For Models Mfd. without Slanted / Tapered Tumbler Ribs

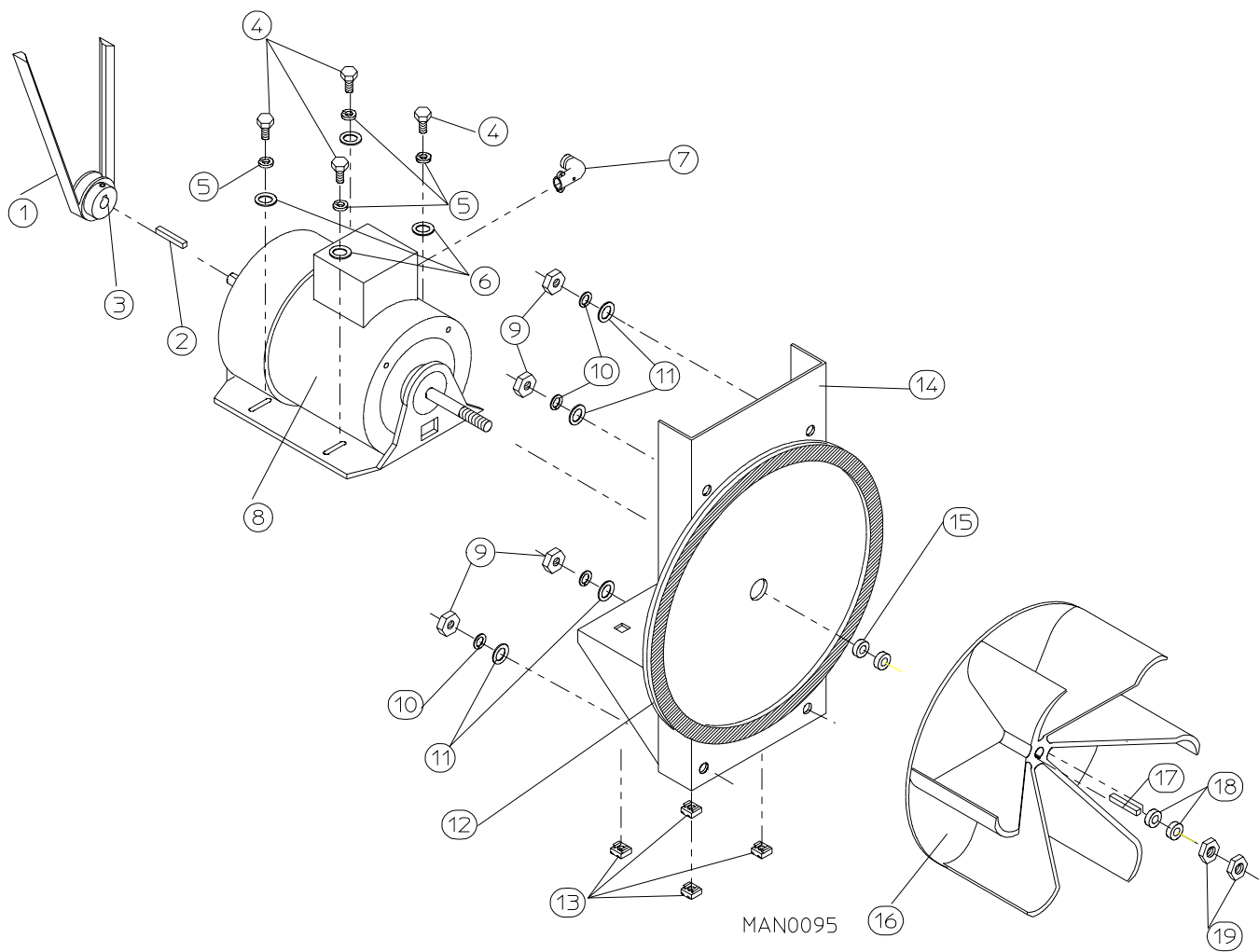

Non-Reversing T.E.F.C. Motor Mount Assembly

For Models Mfd. without Slanted / Tapered Tumbler Ribs

<u>Illus. No.</u>	<u>Part No.</u>	<u>Qty.</u>	<u>Description</u>
1	100117	1	4L 620 V-Belt (motor to idler)
2	100701	1	3/16" x 3/16" x 1" Key
3	101133	1	5/8" x 2-1/4" Motor Pulley (for 60 Hz models Only)
	101130	1	5/8" x 2-1/2" Motor Pulley (for 50 Hz models Only)
4	150501	4	5/16-18 x 3/4" Hex Head Machine Bolt
5	153002	4	5/16" Lock Washer
6	153001	4	5/16" Flat Washer
7	120200	1	3/8" x 90° Connector
8*	100036**	1	1 hp 120/208/230v 1ø 60 Hz Totally Enclosed, Fan-Cooled Motor with 3/4" Shaft (56Z frame) (for models mfd. as of October 25, 1990)
	100032**	1	1 hp 120/208/230v 1ø 60 Hz Totally Enclosed, Fan-Cooled Motor with 1/2" Shaft (56Z frame) (for models mfd. prior to October 25, 1990)
	100076	1	1 hp 230v 1ø 50 Hz Totally Enclosed, Fan-Cooled Motor with 3/4" Shaft (56Z frame) (for models mfd. as of October 25, 1990)
	100034	1	1 hp 230v 1ø 50 Hz Totally Enclosed, Fan-Cooled Motor with 1/2" Shaft (56Z frame) (for models mfd. prior to October 25, 1990)
	100027**	1	1 hp 120/208/230v 3ø 50/60 Hz Totally Enclosed, Fan-Cooled Motor with 1/2" Shaft (56Z frame)
9	152004	4	5/16-18 Hex Nut
10	153002	4	5/16" Lock Washer
11	153001	4	5/16" Flat Washer
12	117604	4	Neoprene Sponge Tape (sold by the foot)
13	154000	4	5/16-18 Tinnerman Nut
14	800919	1	Non-Reversing Motor Mount ONLY (56Z frame)
	803944**	1	1 hp 120/208v 1ø 60 Hz Non-Reversing Totally Enclosed, Fan-Cooled Motor Mount Assembly Complete (includes illus. nos. 2 through 8 and 12 through 19)
	803953	1	3/4 hp 230v 1ø 50 Hz Non-Reversing Totally Enclosed, Fan-Cooled Motor Mount Assembly Complete (includes illus. nos. 2 through 8 and 12 through 19)
	803946**	1	1 hp 230/380/460v 3ø 60 Hz Non-Reversing Totally Enclosed, Fan-Cooled Motor Mount Assembly Complete (includes illus. nos. 2 through 8 and 12 through 19)
	803950**	1	1 hp 230/380/460v 3ø 50 Hz Non-Reversing Totally Enclosed, Fan-Cooled Motor Mount Assembly Complete (includes illus. nos. 2 through 8 and 12 through 19)
15	153051	1	3/4" S.A.E. Flat Washer (for models mfd. with a 3/4" motor shaft)
	153050	***	1/2" S.A.E. Flat Washer (for models mfd. with a 1/2" motor shaft)
16	100603	1	16" Impellor with 3/4" Bore (for models with P/N 100036 or P/N 100076 motor Only)
	100607	1	16" Impellor with 1/2" Bore (for models with P/N 100032, P/N 100034, or P/N 100027 motor Only)
17	100702	1	1/8" x 1/8" x 1-1/2" Key
18	153050	***	1/2" S.A.E. Flat Washer
19	152006	2	1/2-20 Left Hand Jam Nut

* Check part number on motor data label to verify correct motor.

** Specify voltage when ordering.

***As required.

Reversing T.E.F.C. Motor Mount Assembly

For Models Mfd. without Slanted / Tapered Tumbler Ribs

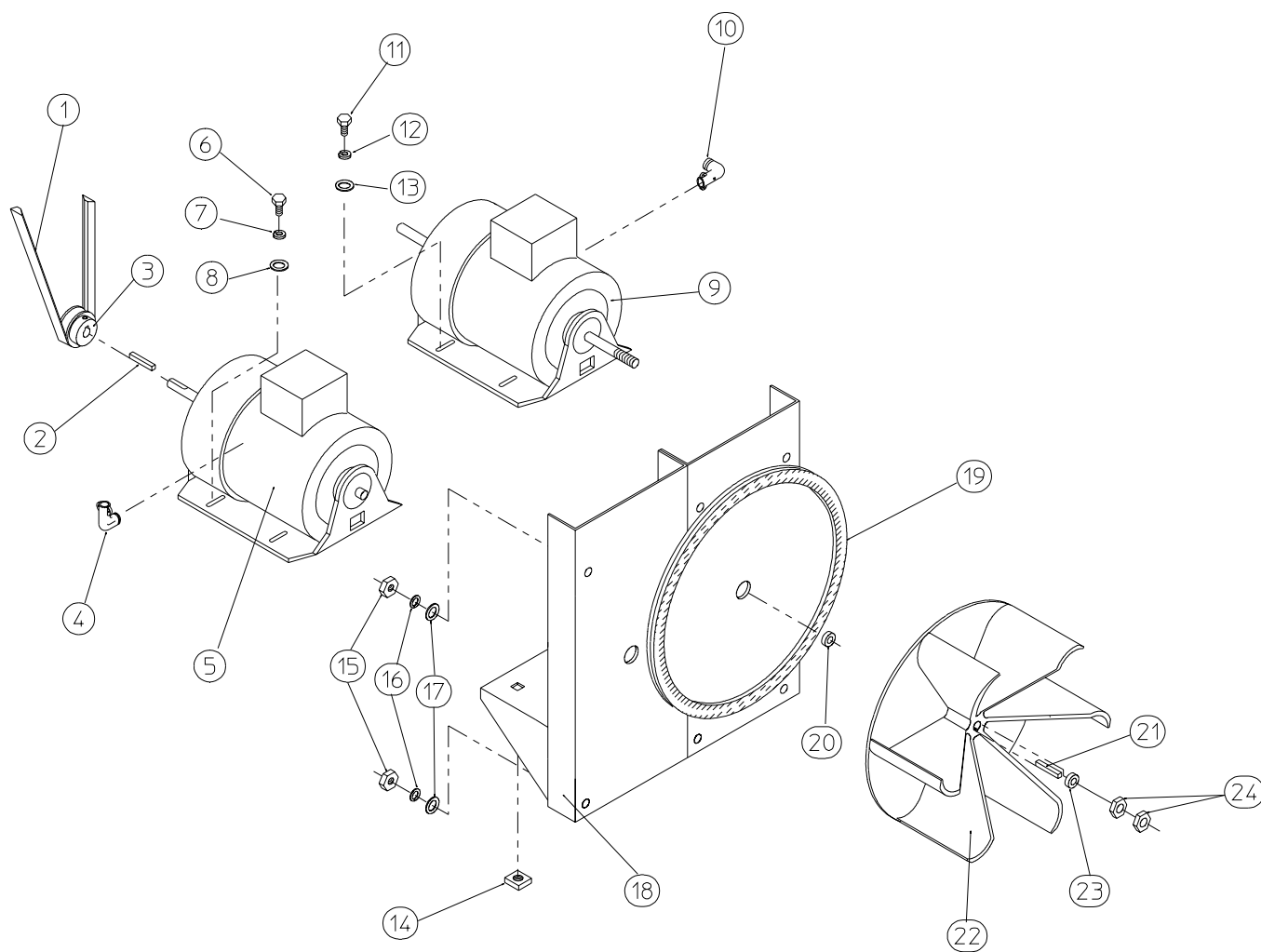

MAN0250

Reversing T.E.F.C. Motor Mount Assembly

For Models Mfd. without Slanted / Tapered Tumbler Ribs

<u>Illus. No.</u>	<u>Part No.</u>	<u>Qty.</u>	<u>Description</u>
1	100117	1	4L-620 V-Belt (motor to idler) for All Models Except 50 Hz Reversing
	100114	1	4L-630 V-Belt (motor to idler) for 50 Hz Reversing Models ONLY
2	100701	1	3/16" x 3/16" x 1" Key
3	101133	1	5/8" x 2-1/4" Motor Pulley (for 60 Hz models Only)
	101130	1	5/8" x 2-1/2" Motor Pulley (for 50 Hz models Only)
4	120200	1	3/8" x 90° Connector
5*	181003**	1	1/2 hp 208/230/380/460v 3ø 50/60 Hz Totally Enclosed, Fan-Cooled Motor (56Z frame)
6	150501	4	5/16-18 x 3/4" Hex Head Machine Bolt
7	153002	4	5/16" Lock Washer
8	153001	4	5/16" Flat Washer
9*	100027**	1	1 hp 208/220/230/380/460v 3ø 50/60 Hz Totally Enclosed, Fan-Cooled Motor with 1/2" Shaft (56Z frame) (for models mfd. prior to May 16, 1988)
	100030**	1	1 hp 208/220/230/380/460v 3ø 50/60 Hz Totally Enclosed, Fan-Cooled Motor with 3/4" Shaft (56Z frame) (for models mfd. between May 16, 1988 thru December 19, 1991)
10	120200	1	3/8" x 90° Connector
11	150501	4	5/16-18 x 3/4" Hex Head Machine Bolt
12	153002	4	5/16" Lock Washer
13	153001	4	5/16" Flat Washer
14	154000	8	5/16-18 Tinnerman Nut
15	152004	7	5/16-18 Hex Nut
16	153002	7	5/16" Lock Washer
17	153001	4	5/16" Flat Washer
14	800920	1	Reversing Motor Mount ONLY (56Z frame)
	803948**	1	60 Hz Reversing Totally Enclosed, Fan-Cooled Motor Mount Assembly Complete (includes illus. nos. 2 through 14 and 18 through 24)
	803951**	1	60 Hz Reversing Totally Enclosed, Fan-Cooled Motor Mount Assembly Complete (includes illus. nos. 2 through 14 and 18 through 24)
15	152004	7	5/16-18 Hex Nut
16	153002	7	5/16" Lock Washer
17	153001	7	5/16" Flat Washer
18	800920	1	Reversing Motor Mount ONLY (56Z frame)
	803948**	1	60 Hz Reversing Totally Enclosed, Fan-Cooled Motor Mount Assembly Complete (includes illus. nos. 2 through 14 and 18 through 24)
	803951**	1	50 Hz Reversing Totally Enclosed, Fan-Cooled Motor Mount Assembly Complete (includes illus. nos. 2 through 14 and 18 through 24)
19	117604	4	Neoprene Sponge Tape (sold by the foot)
20	153051	1	3/4" S.A.E. Flat Washer (for models mfd. with a 3/4" motor shaft)
	153050	***	1/2" S.A.E. Flat Washer (for models mfd. with a 1/2" motor shaft)
21	100702	1	1/8" x 1/8" x 1-1/2" Key
22	100603	1	16" Impellor with 3/4" Bore (for models with P/N 100030 motor Only)
	100607	1	16" Impellor with 1/2" Bore (for models with P/N 100027 motor Only)
23	153050	***	1/2" S.A.E. Flat Washer
24	152006	2	1/2-20 Left Hand Jam Nut

* Check part number on motor data label to verify correct motor.

** Specify voltage when ordering.

***As required.

Sensor Bracket Assemblies

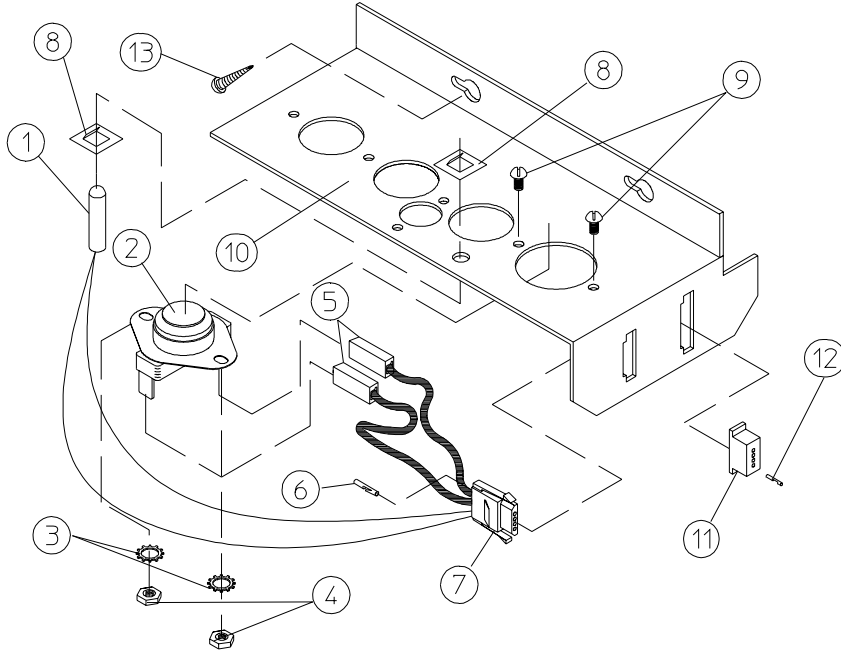

MICROPROCESSOR SENSOR BRACKET ASSEMBLY

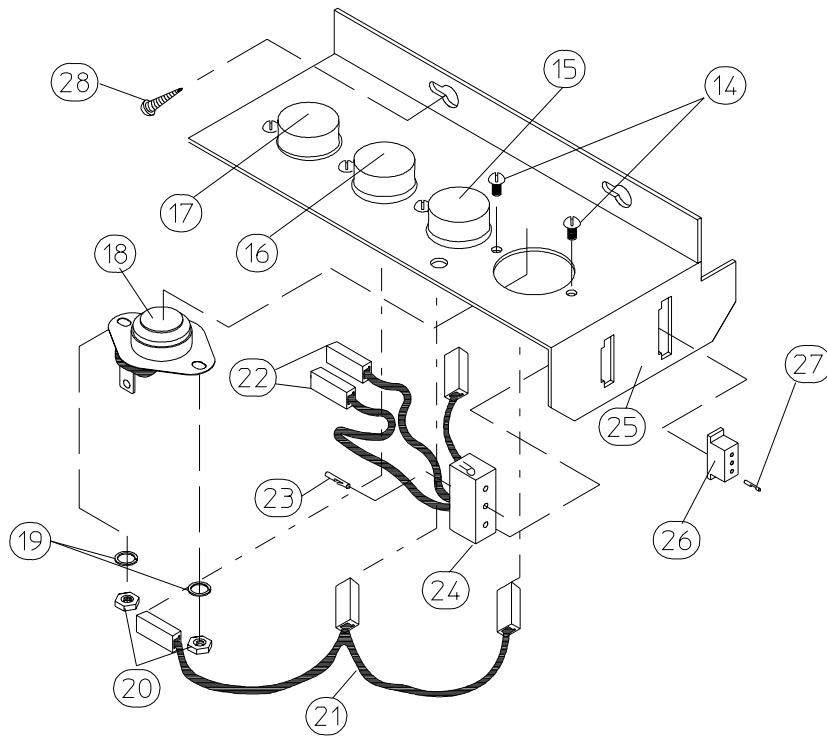

NON-COMPUTER SENSOR BRACKET ASSEMBLY

MAN0238

<u>Illus. No.</u>	<u>Part No.</u>	<u>Qty.</u>	<u>Description</u>
1	880251	1	1/4" Temperature Sensor Probe Assembly (includes illus. nos. 1 and 5 through 8)
2	130103	1	225° Large Automatic Reset Thermostat
3	153010	2	#6 Star Washer
4	152000	2	#6-32 Hex Nut
5	121028	2	Insulated Terminal ONLY
6	122701	4	Socket Terminal ONLY
	122801	1	Pin / Socket Extraction Tool
7	122605	1	4-Pin Socket Connector ONLY
8	154007	2	1/4" Tinnerman Push-On Fastener
9	150005	2	#6-32 x 1/4" Phillips Round Head Machine Screw
10	801425	1	Microprocessor Sensor Bracket Assembly Complete (includes illus. nos. 1 through 10)
	305007	1	Universal Sensor Bracket ONLY
11	122604	1	4-Pin Connector ONLY
12	122700	4	Pin Terminal ONLY
13	150301	2	#8-18 x 7/16" Phillips Pan Head TEK Screw
14	150005	*	#6-32 x 1/4" Phillips Round Head Machine Screw
15	130111	1	130° Large Thermostat (for ADC models Only)
	130109	1	140° Large Thermostat (for UniDryer® models Only)
16	130100	1	150° Large Automatic Reset Thermostat (for ADC models Only)
	130107	1	160° Large Thermostat (for UniDryer® models Only)
17	130103	1	225° Large Automatic Reset Thermostat
18	130101	1	180° Large Thermostat
19	153010	*	#6 Star Washer
20	152000	*	#6-32 Hex Nut
21	840063	1	Sensor Jumper (3) ONLY (for ADC models Only)
	840065	1	Sensor Jumper (4) ONLY (for UniDryer® models Only)
22	121028	*	Insulated Terminal ONLY
23	122701	*	Socket Terminal ONLY
24	122609	1	3-Pin Socket Connector ONLY (for ADC models Only)
	122605	1	4-Pin Socket Connector ONLY (for UniDryer® models Only)
	831702	1	Sensor (3) Bracket Harness Assembly (for ADC models Only) (includes illus. nos. 22, 23, and 24)
	840062	1	Sensor (4) Bracket Harness Assembly (for UniDryer® models Only) (includes illus. nos. 22, 23, and 24)
25	801405	1	Non-Computer Sensor (3) Bracket Assembly Complete with Thermostats (for ADC models Only) (includes illus. nos. 14 through 25)
	801411	1	Non-Computer Sensor (4) Bracket Assembly Complete with Thermostats (for UniDryer® models Only) (includes illus. nos. 14 through 25)
	305007	1	Universal Sensor Bracket ONLY
26	122608	1	3-Pin Connector ONLY (for ADC models Only)
	122604	1	4-Pin Connector ONLY (for UniDryer® models Only)
27	122700	*	Pin Terminal ONLY
28	150301	2	#8-18 x 7/16" Phillips Pan Head TEK Screw

* As required.

Direct Spark Ignition Upshot Burner Assembly

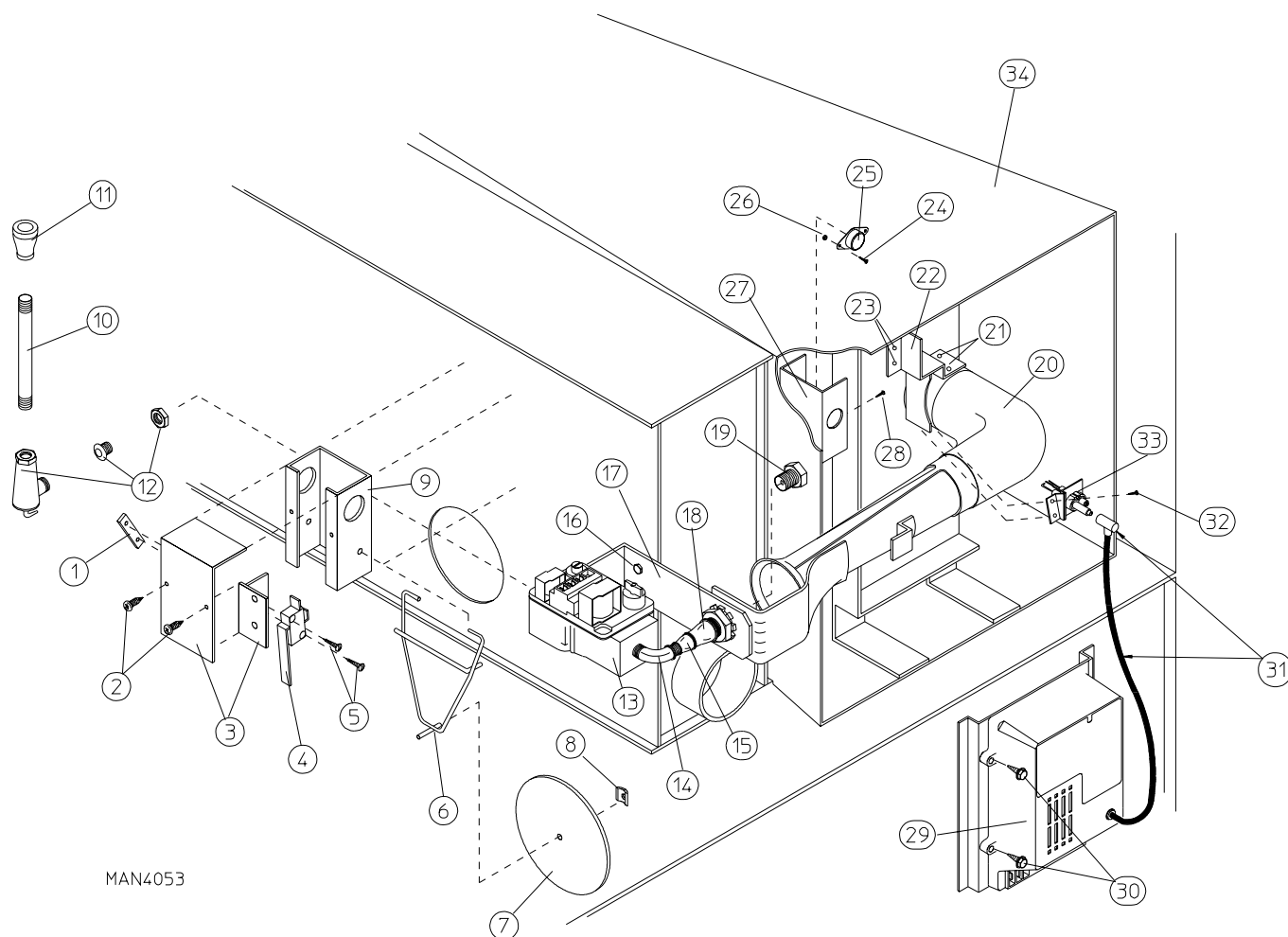

MAN4053

<u>Illus. No.</u>	<u>Part No.</u>	<u>Qty.</u>	<u>Description</u>
1	154004	1	Twin Speed Nut
2	150309	2	#10-16 x 1/2" Hex Head TEK Crimptite Screw
3	802799	1	Sail Switch Box Cover and Bracket ONLY
4	122200	1	Sail Switch ONLY
5	150303	2	#4 x 3/4" Pan Head "A" Machine Screw
6	105500	1	Sail Switch Actuator Rod
7	319202	1	Sail Switch Damper (flat)
8	154002	1	1/8" Push-On Fastener
9	802802	1	Sail Switch Box with Cover and Bracket ONLY
	802801	1	Sail Switch Box Assembly Complete (includes illus. nos. 1 through 9)
10	142812	1	1/2" x 3" Nipple

Direct Spark Ignition Upshot Burner Assembly

<u>Illus. No.</u>	<u>Part No.</u>	<u>Qty.</u>	<u>Description</u>
11	143000	1	1/2" x 3/4" Reducing Coupling
12	881367	1	1/2" Union Shutoff with Tail Piece
13	128927	1	1/2" 24 VAC Redundant (natural gas) Gas Valve
	140411	1	1/2" 24 VAC Gas Valve (liquid propane) Conversion Kit
14	142506	1	1/2" x 1/2" Street Elbow
15	142707	1	1/2" x 1-1/2" Nipple
16	150300	2	#10 x 1/2" Hex Washer TEK Screw
17	318710	1	1-Piece Gas Valve Train Mounting Bracket
	318505	1	Gas Burner Support Bracket (for models mfd. prior to December 21, 1988)
	318505	1	Gas Valve Support Bracket (for models mfd. prior to December 21, 1988)
18	143000	1	1/2" x 3/4" Reducing Coupling
19*	141153	1	#H Burner Orifice (natural gas) ONLY
	141152	1	#21 Burner Orifice (liquid propane) ONLY
20	141150	1	Upshot Burner with Shutter and Spreader
21	150301	2	#8-18 x 7/16" Phillips Pan Head TEK Screw
22	318708	1	Upshot Burner Assembly Bracket Support
23	150300	2	#10 x 1/2" Hex Washer Screw
24	150001	2	#6-32 x 1/2" Slotted Round Head Machine Screw
25	130401	1	330° Hi-Limit
26	151000	2	#6-32 Pal Nut
27	318707	1	Hi-Limit Mounting Bracket ONLY
28	150300	2	#10 x 1/2" Hex Washer TEK Screw
29	883849	1	Direct Spark Ignition Module
30	150299	4	#10-16 x 1/2" Hex Washer TEK Screw
31	874048	1	Ignitor / Flame-Probe Assembly Kit (includes high voltage wire connector)
	305410	1	Direct Spark Ignition Ignitor Gap Feeler Gauge ... Not Illustrated
32	150300	2	#10 x 1/2" Hex Washer Screw
33	880330	1	Direct Spark Ignition Ignitor High Voltage Wire / Connector ONLY
34	804001	1	Non-Heat Reclaimer Burner Box ONLY
	804002	1	Heat Reclaimer Burner Box ONLY
	809619**	1	Non-Heat Reclaimer Natural Gas Burner Assembly Complete Less Orifice (includes illus. nos. 1 through 18 and 20 through 32)
	809620**	1	Non-Heat Reclaimer Liquid Propane Gas Burner Assembly Complete Less Orifice (includes illus. nos. 1 through 18 and 20 through 32)
	809621**	1	Heat Reclaimer Natural Gas Burner Assembly Complete Less Orifice (includes illus. nos. 1 through 18 and 20 through 32)
	809622**	1	Heat Reclaimer Liquid Propane Gas Burner Assembly Complete Less Orifice (includes illus. nos. 1 through 18 and 20 through 32)
	874042*	1	Burner Liquid Propane Conversion Kit with Orifice
	874042*	1	Liquid Propane Conversion Kit with Orifice

* Consult factory for elevations over 2,000 feet.

** Burner orifice is not included and must be ordered separately.

Electric Oven Assembly

For Models Mfd. as of November 12, 1990

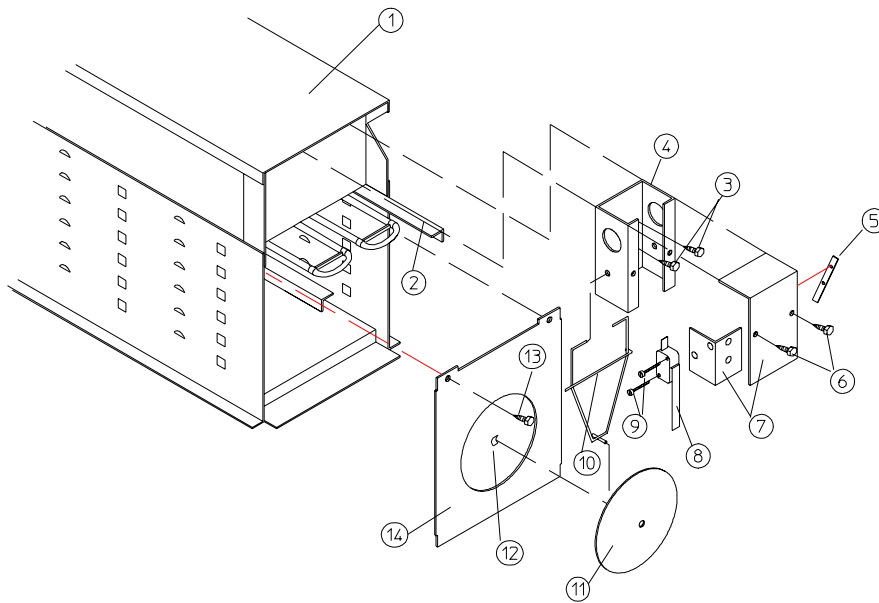

ELECTRIC OVEN (FRONT VIEW)

MAN4056

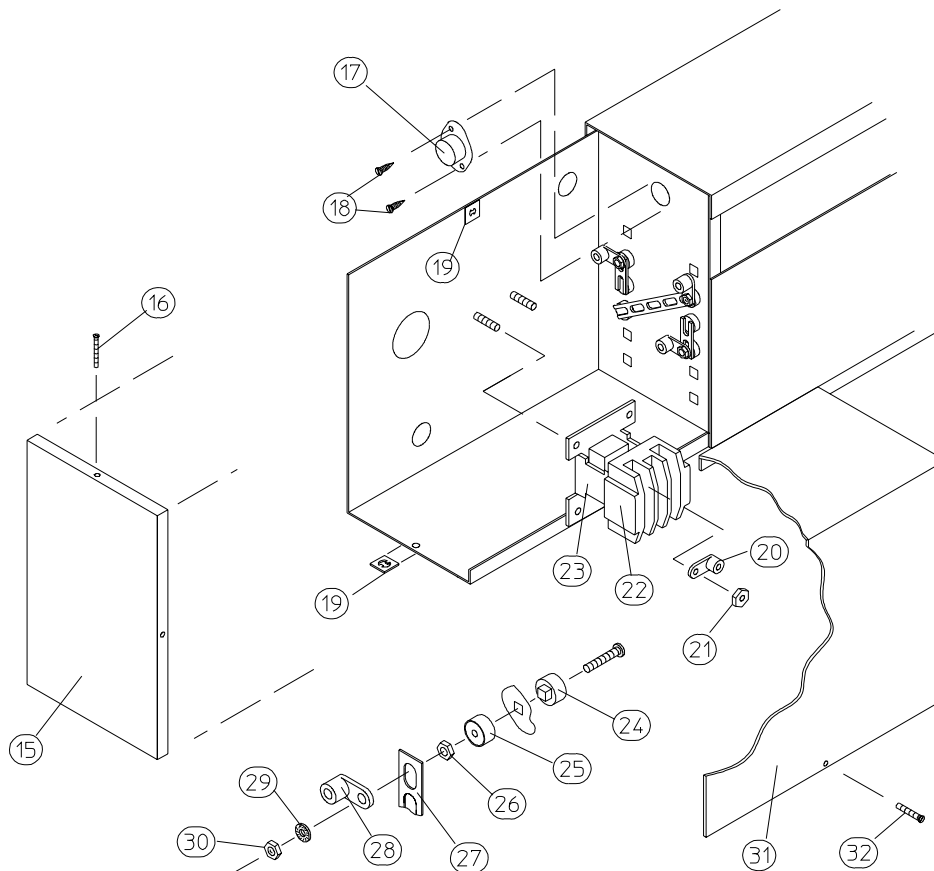

ELECTRIC OVEN (REAR VIEW)

<u>Illus. No.</u>	<u>Part No.</u>	<u>Qty.</u>	<u>Description</u>
1	803001	1	Large Electric Oven Box ONLY
	-----*	1	Electric Oven Assembly Complete
2	-----*	-	Electric Element
3	150300	2	#10 x 1/2" Hex Washer TEK Screw
4	802800	1	Sail Switch Box with Bracket and Cover ONLY
	802801	1	Sail Switch Box Assembly Complete (includes illus. nos. 4 through 12)
5	154004	1	Twin Speed Nut
6	150309	2	#10-16 x 1/2" Hex Head TEK Crimptite Screw
7	802799	1	Sail Switch Box Cover and Bracket ONLY
8	122200	1	Sail Switch ONLY
9	150303	2	#4 x 3/4" Pan Head "A" Machine Screw
10	105500	1	Sail Switch Actuator Rod
11	319202	1	Sail Switch Damper (flat)
12	154002	1	1/8" Push-On Fastener
13	150300	2	#10 x 1/2" Hex Washer TEK Screw
14	803100	1	Electric Oven Front Cover ONLY
15	321000	1	Large Relay Box Cover ONLY
16	150402	2	#10-24 x 5/8" Slotted Truss Head Machine Screw
17	130400	1	290° Hi-Limit
18	150300	2	#10 x 1/2" Hex Washer TEK Screw
19	154001	2	#10-24 Speed Nut
20	121010	1	L-70 Ground Lug
21	152014	3	1/4-20 Free Spin Wash Nut
22	-----*	1	Oven Relay
23	-----*	1	Oven Relay Replacement Coil
24	120081	-	Internal Ceramic Insulator (2 per element)
25	120080	-	External Ceramic Insulator (2 per element)
26	152008	-	#10-32 Hex Nut (2 per element)
27	121011*	-	Bus Bar
28	-----*	-	Terminal Lug
29	153009	-	#10 Star Washer (2 per element)
30	152008	-	#10-32 Hex Nut (2 per element)
31	320607	1	Large Electric Oven Right Side Cover ONLY
32	150402	2	#10-24 x 5/8" Truss Head Machine Screw

* Refer to Electric Oven Component Application Chart on page 47.

Electric Oven Assembly

For Models Mfd. prior to November 12, 1990

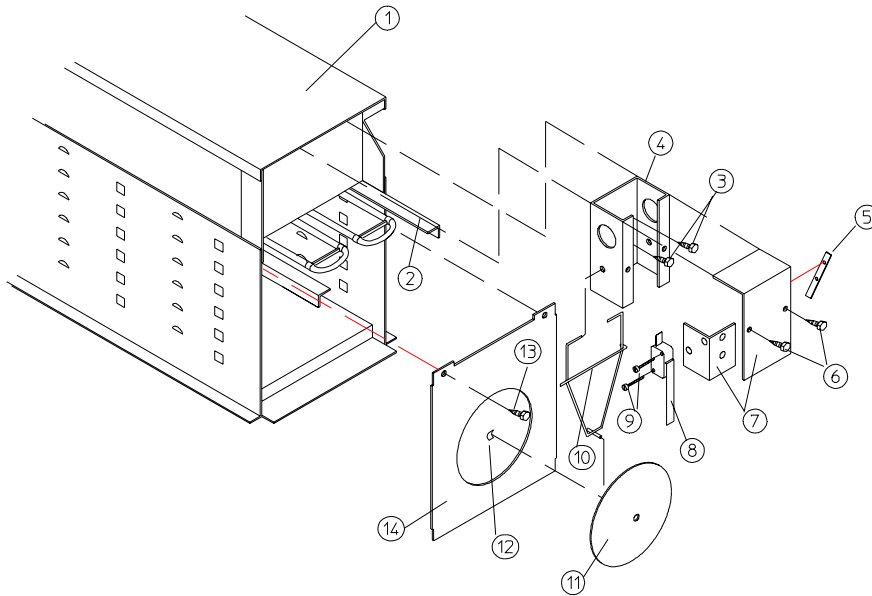

ELECTRIC OVEN (FRONT VIEW)

MAN4055

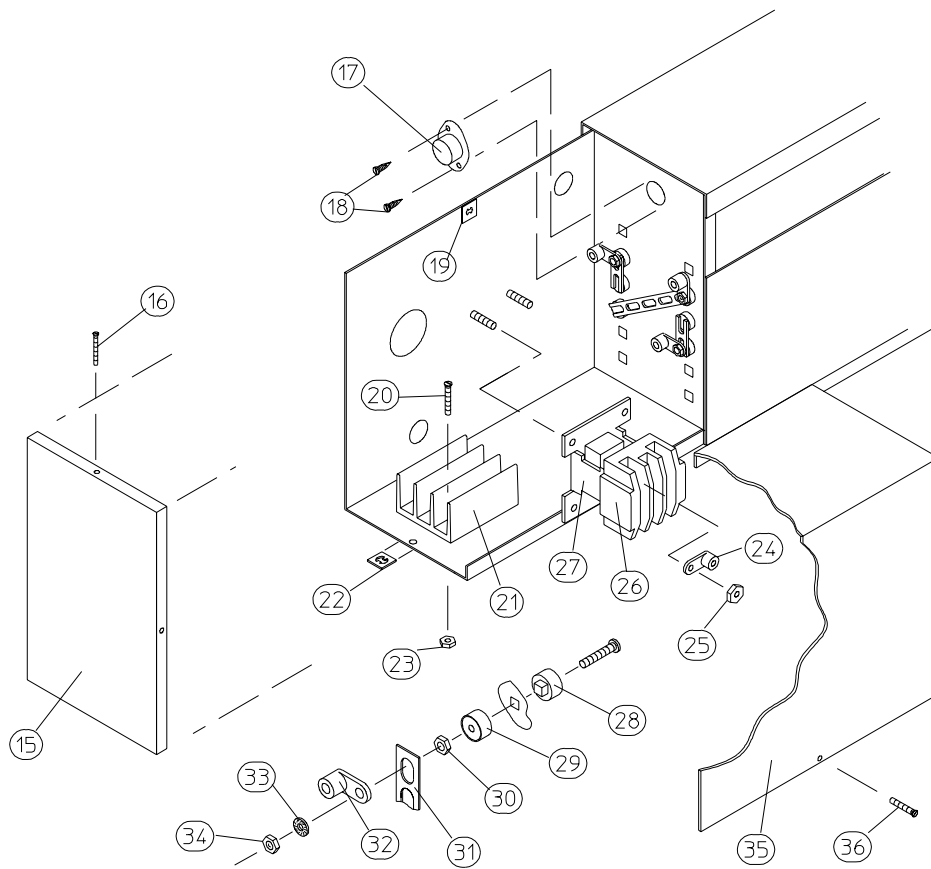

ELECTRIC OVEN (REAR VIEW)

For Models Mfd. prior to November 12, 1990

<u>Illus. No.</u>	<u>Part No.</u>	<u>Qty.</u>	<u>Description</u>
1	803001	1	Large Electric Oven Box ONLY
	-----*	1	Electric Oven Assembly Complete
2	-----*	-	Electric Element
3	150300	2	#10 x 1/2" Hex Washer TEK Screw
4	802800	1	Sail Switch Box with Bracket and Cover ONLY
	802801	1	Sail Switch Box Assembly Complete (includes illus. nos. 4 through 12)
5	154004	1	Twin Speed Nut
6	150309	2	#10-16 x 1/2" Hex Head TEK Crimptite Screw
7	802799	1	Sail Switch Box Cover and Bracket ONLY
8	122200	1	Sail Switch ONLY
9	150303	2	#4 x 3/4" Pan Head "A" Machine Screw
10	105500	1	Sail Switch Actuator Rod
11	319202	1	Sail Switch Damper (flat)
12	154002	1	1/8" Push-On Fastener
13	150300	2	#10 x 1/2" Hex Washer TEK Screw
14	803100	1	Electric Oven Front Cover ONLY
15	321000	1	Large Relay Box Cover ONLY
16	150402	2	#10-24 x 5/8" Slotted Truss Head Machine Screw
17	130400	1	290° Hi-Limit
18	150300	2	#10 x 1/2" Hex Washer TEK Screw
19	154001	2	#10-24 Speed Nut
20	150103	2	#8-32 x 3/4" Round Head Machine Screw
21	120704*	-	Terminal Block
22	154001	2	#10-24 Speed Nut
23	152001	2	#8-32 Hex Nut
24	121010	1	L-70 Ground Lug
25	152014	3	1/4-20 Free Spin Wash Nut
26	-----*	1	Oven Relay
27	-----*	1	Oven Relay Replacement Coil
28	120081	-	Internal Ceramic Insulator (2 per element)
29	120080	-	External Ceramic Insulator (2 per element)
30	152008	-	#10-32 Hex Nut (2 per element)
31	121011*	-	Bus Bar
32	-----*	-	Terminal Lug
33	153009	-	#10 Star Washer (2 per element)
34	152008	-	#10-32 Hex Nut (2 per element)
35	320607	1	Large Electric Oven Right Side Cover ONLY
36	150402	2	#10-24 x 5/8" Truss Head Machine Screw

* Refer to Electric Oven Component Application Chart on page 48.

3-Phase (3Ø) Motor, Electric Relay Panel Assembly

For Models Mfd. with 208-240 Volt Controls – Telemecanique

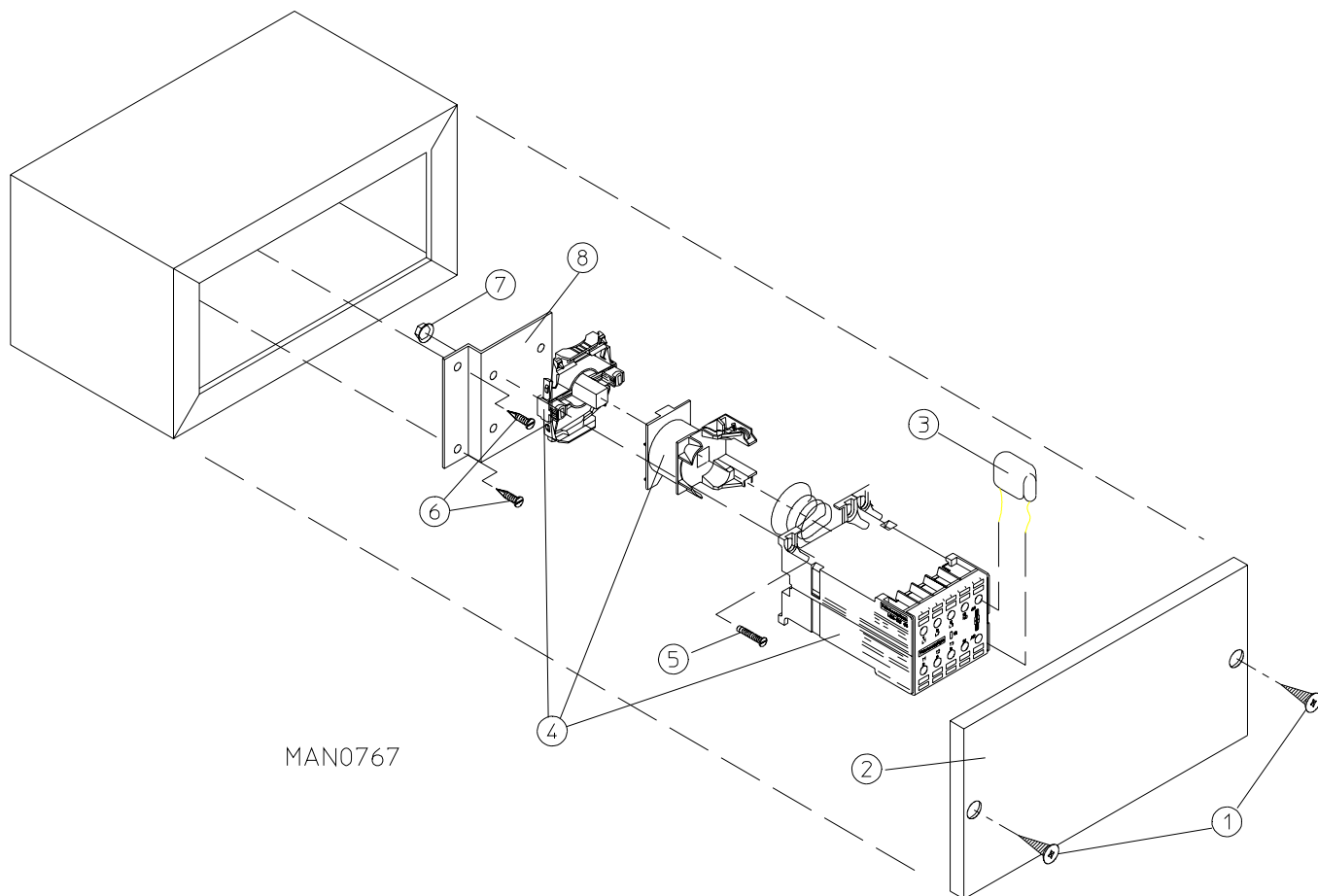

Illus. No.	Part No.	Qty.	Description
1	150309	2	#10-16 x 1/2" Hex Head TEK Crimptite Screw
2	311913	1	Service Box Cover Plate (9-7/8" x 4-3/8")
3*	137015	1	Arc Suppressor (capacitor) ONLY
4	132425	1	Impellor Contactor (208/230/240v – 50/60 Hz)
	132427	1	Impellor Contactor Replacement Coil (208/230/240v – 50/60 Hz)
5	150100	4	#8-32 x 1/2" Phillips Pan Head Machine Screw
6	150300	2	#10-16 x 1/2" Hex Washer TEK Screw
7	151001	4	#8-32 Pal Nut
8	311920	1	3-Phase (3Ø) Non-Reversing Contactor Mounting Bracket

* For use on 3-phase (3Ø) non-reversing microprocessor (computer) models ONLY.

3-Phase (3Ø) Motor, Electric Relay Panel Assembly

For Models Mfd. with 208-240 Volt Controls – Furnas

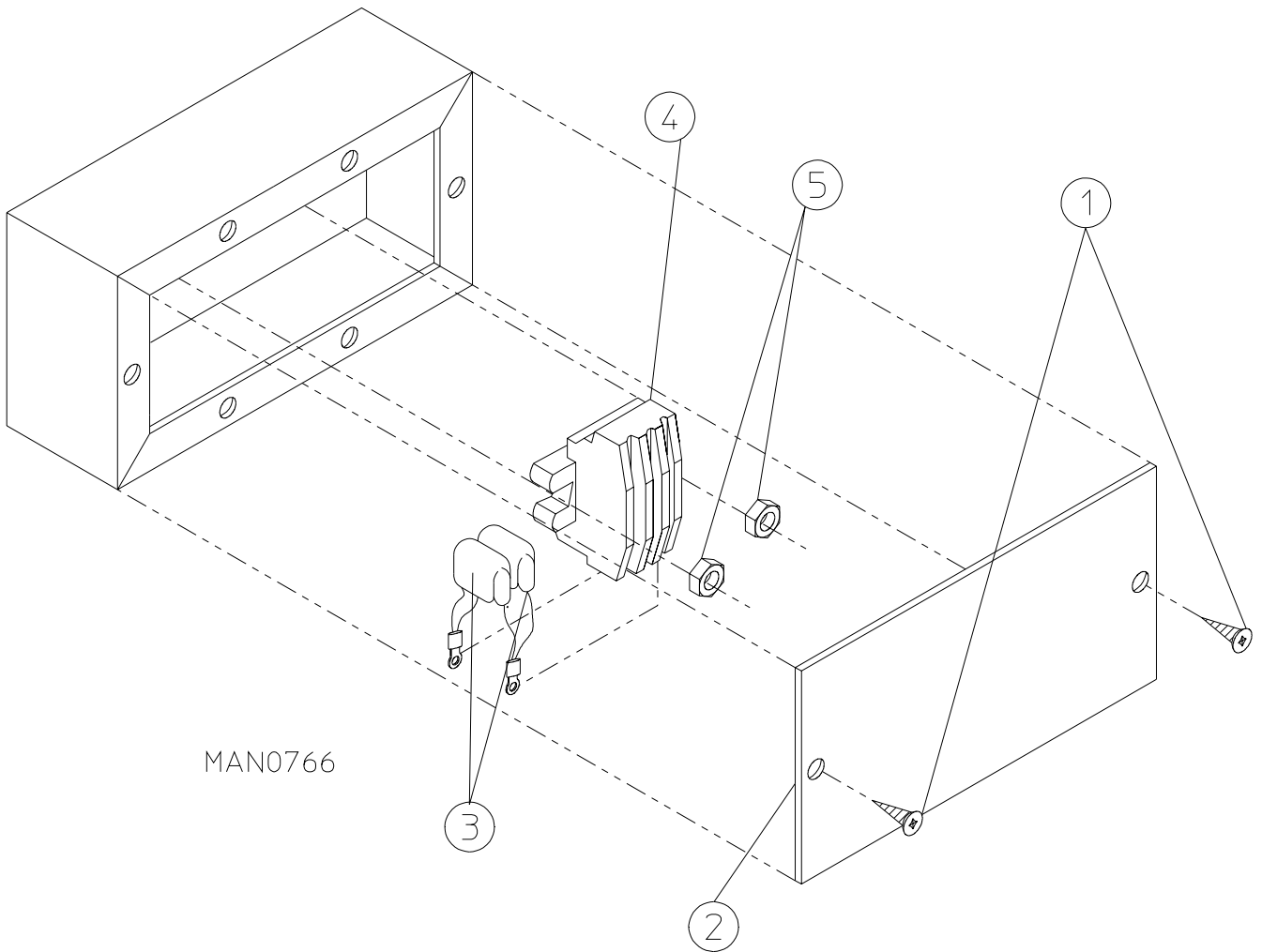

Illus. No.	Part No.	Qty.	Description
1	150309	2	#10-16 x 1/2" Hex Head TEK Crimptite Screw
2	311913	1	Service Box Cover Plate (9-7/8" x 4-3/8")
	311921	1	Service Box Cover Plate (9-7/8" x 5-3/4")
3*	880662	1	Dual RC Suppressors ONLY
4	132400	1	Impellor Contactor (208/230/240v – 50/60 Hz)
5	150100	4	#8-32 x 1/2" Phillips Pan Head Machine Screw
	151001	4	#8-32 Pal Nut

* Used on microprocessor (computer) models ONLY.

Microprocessor Reversing Rear Control Box Assembly

For Models Mfd. with 208-240 Volt Controls – Telemecanique

For Models Mfd. as of December 1, 1988

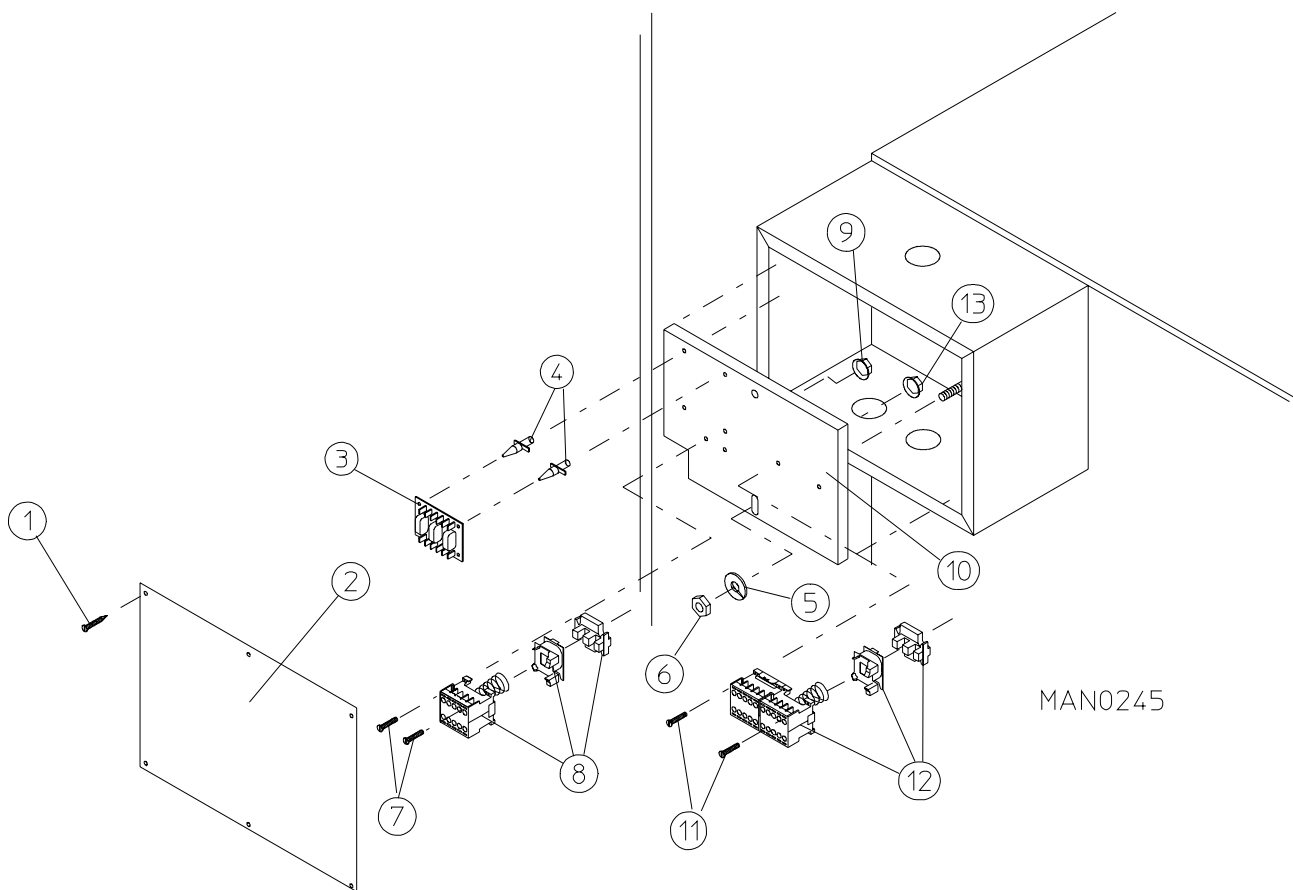

Illus. No.	Part No.	Qty.	Description
1	150301	6	#8-18 x 7/16" Phillips Pan Head TEK Screw
2	322812	1	Relay Box Cover ONLY
3	137060	1	Arc Suppressor Board (3)
4	137013	4	Nylon Standoff
5	153002	2	5/16" Lock Washer
6	152004	2	5/16-18 Hex Nut
7	150108	4	#8-32 x 3/4" Phillips Pan Head Machine Screw
8	132425	1	Impellor Contactor (208/230/240v – 50/60 Hz)
	132427	1	Impellor Contactor Replacement Coil (208/230/240v – 50/60 Hz)
9	151001	4	#8-32 Pal Nut
10	322807	1	Contactator Mounting Panel ONLY
11	150108	4	#8-32 x 3/4" Phillips Pan Head Machine Screw
12	132426	1	Reversing Contactor (208/230/240v – 50/60 Hz)
	132427	1	Reversing Contactor Replacement Coil (208/230/240v – 50/60 Hz)
13	151001	4	#8-32 Pal Nut

Microprocessor Reversing Rear Control Box Assembly

For Models Mfd. with 208-240 Volt Controls – Struthers-Dunn
 For Models Mfd. prior to December 1, 1988

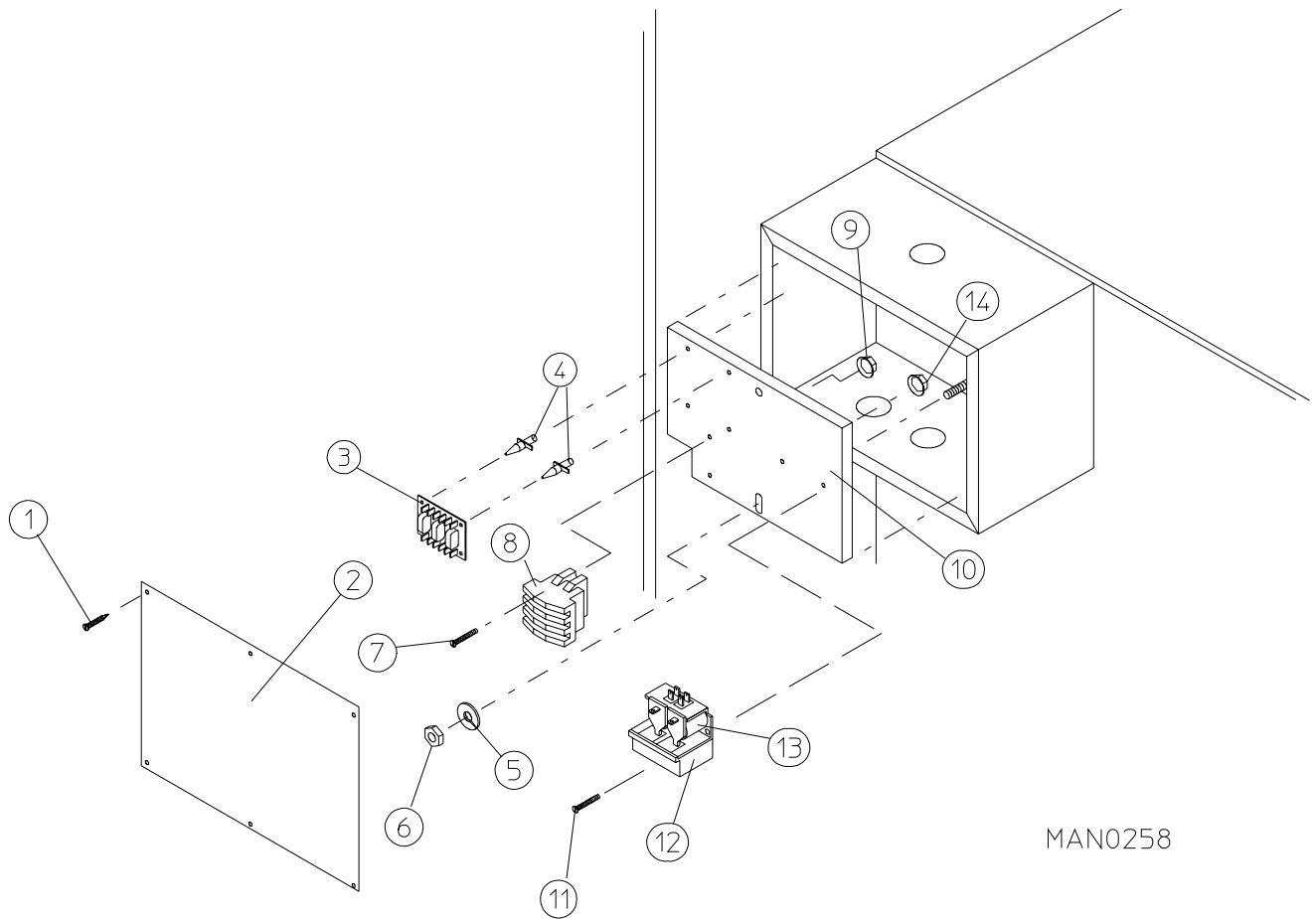

MAN0258

Illus. No.	Part No.	Qty.	Description
1	150301	6	#8-18 x 7/16" Phillips Pan Head TEK Screw
2	322812	1	Control Box Cover Plate ONLY
3	137060	1	Arc Suppressor Board (3)
4	137013	4	Nylon Standoff
5	153002	2	5/16" Lock Washer
6	152004	2	5/16-18 Hex Nut
7	150108	4	#8-32 x 3/4" Phillips Pan Head Machine Screw
8	132400	1	Impellor Contactor (208/230/240v – 50/60 Hz)
9	151001	4	#8-32 Pal Nut
10	322807	1	Contacting Mounting Panel ONLY
11	150108	4	#8-32 x 3/4" Phillips Pan Head Machine Screw
12	132404	1	Reversing Contactor (208v – 50/60 Hz)
	132401	1	Reversing Contactor (240v – 50/60 Hz)
13	132416	1	Reversing Contactor Replacement Coil (208v – 60 Hz)
	132415	1	Reversing Contactor Replacement Coil (240v – 60 Hz)
	132407	1	Reversing Contactor Replacement Coil (240v – 50 Hz)
14	151001	4	#8-32 Pal Nut

Dual Timer Reversing Rear Control Box Assembly

For Models Mfd. with 208-240 Volt Controls – Telemecanique

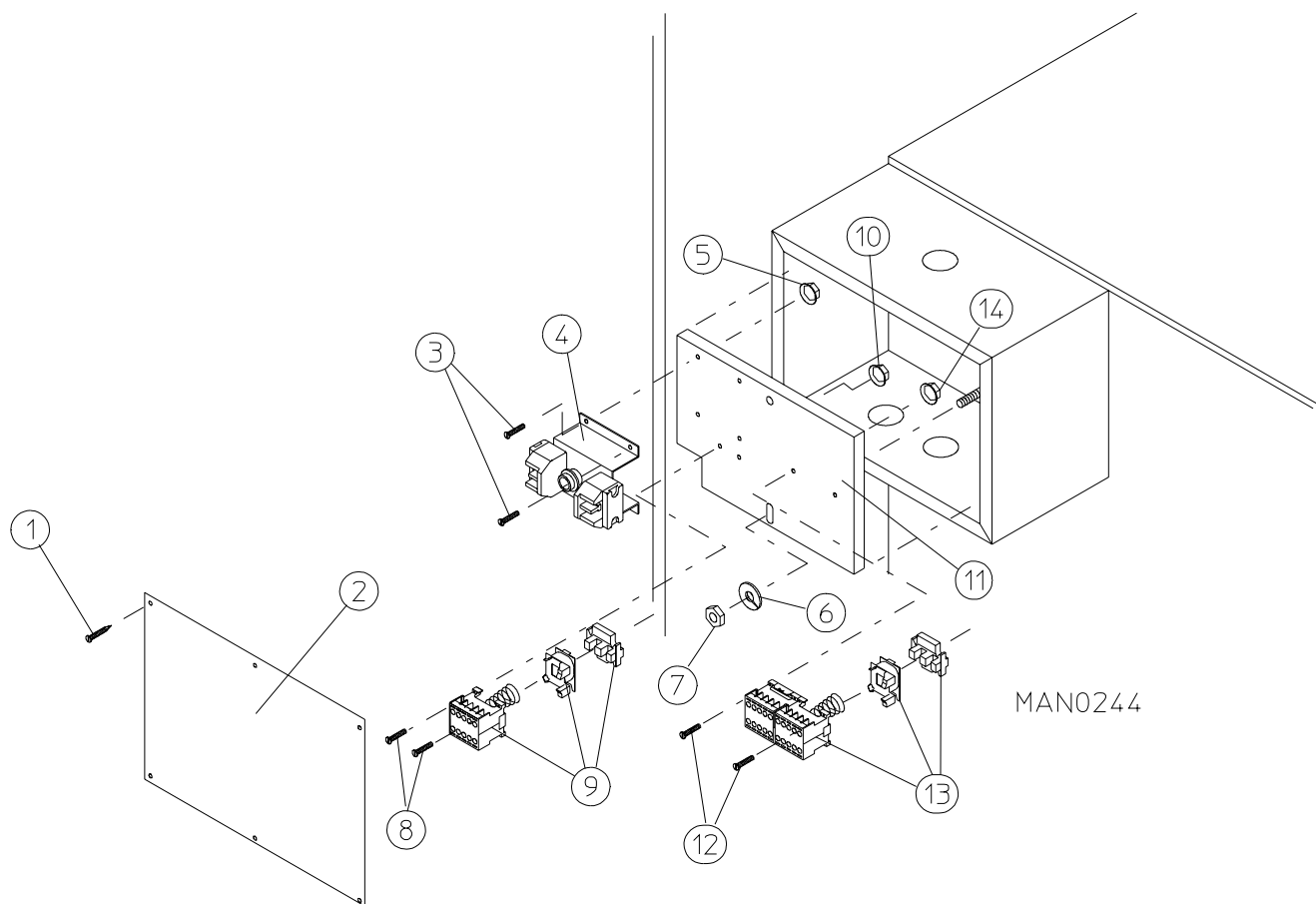

Illus. No.	Part No.	Qty.	Description
1	150301	6	#8-18 x 7/16" Phillips Pan Head TEK Screw
2	322808	1	Relay Box Cover Plate ONLY
3	150108	2	#8-32 x 3/4" Phillips Pan Head Machine Screw
4	132200	1	Reversing Timer (for 60 Hz models Only)
	132202	1	Reversing Timer (for 50 Hz models Only)
5	151001	2	#8-32 Pal Nut
6	153002	2	5/16" Lock Washer
7	152004	2	5/16-18 Hex Nut
8	150108	4	#8-32 x 3/4" Phillips Pan Head Machine Screw
9	132426	1	Impellor Contactor (208/230/240v – 50/60 Hz)
	132427	1	Impellor Contactor Replacement Coil (208/230/240v – 50/60 Hz)
10	151001	4	#8-32 Pal Nut
11	322807	1	Contactor Mounting Plate ONLY
12	150108	4	#8-32 x 3/4" Phillips Pan Head Machine Screw
13	132426	1	Reversing Contactor (208/230/240v – 50/60 Hz)
	132427	2	Reversing Contactor Replacement Coil (208/230/240v – 50/60 Hz)
14	151001	4	#8-32 Pal Nut

Dual Timer Reversing Rear Control Box Assembly

For Models Mfd. with 208-240 Volt Controls – Struthers-Dunn

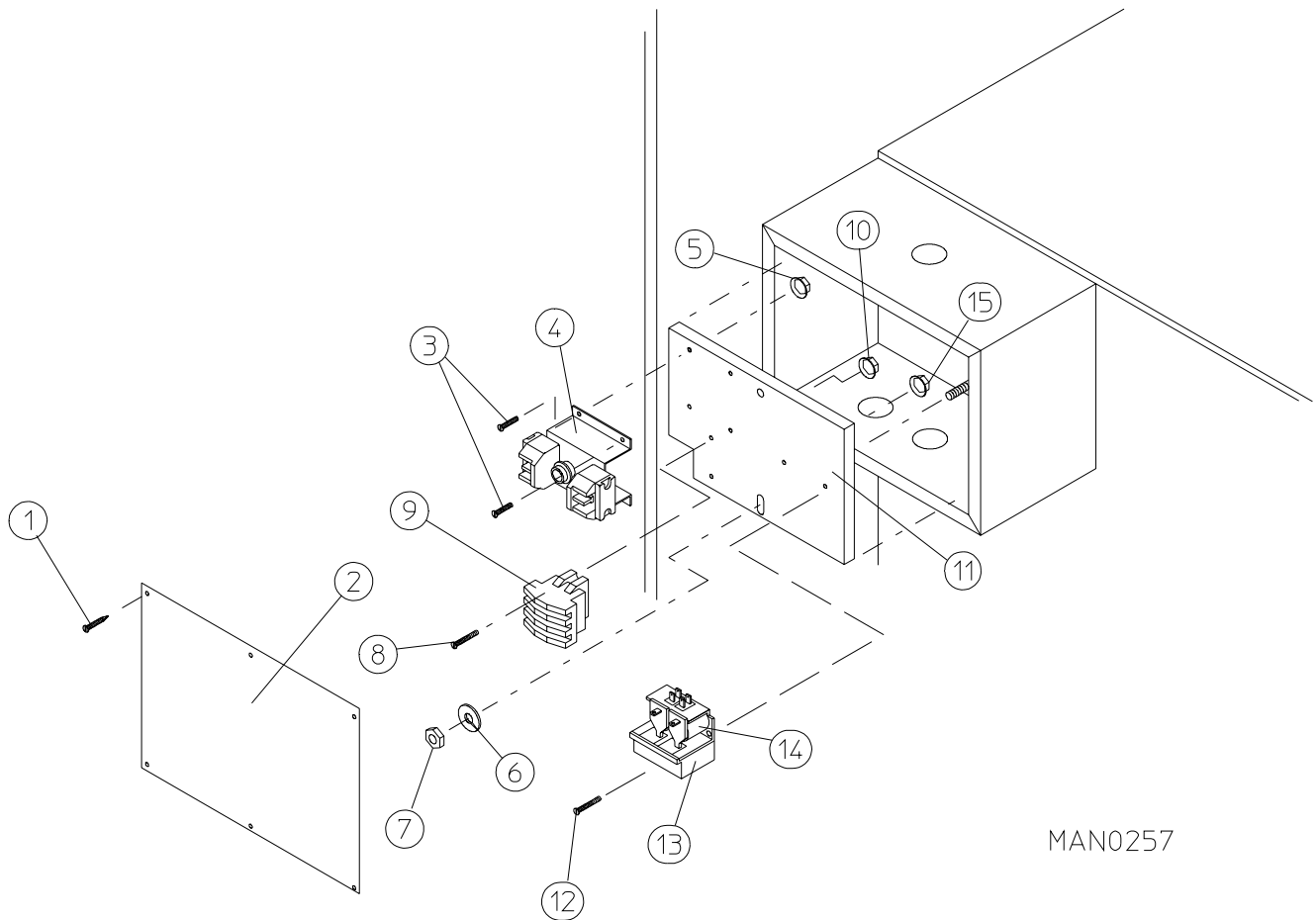

MAN0257

<u>Illus. No.</u>	<u>Part No.</u>	<u>Qty.</u>	<u>Description</u>
1	150301	6	#8-18 x 7/16" Phillips Pan Head TEK Screw
2	322808	1	Relay Box Cover Plate ONLY
3	150108	2	#8-32 x 3/4" Phillips Pan Head Machine Screw
4	132200	1	Reversing Timer (for 60 Hz models Only)
	132202	1	Reversing Timer (for 50 Hz models Only)
5	151001	2	#8-32 Pal Nut
6	153002	2	5/16" Lock Washer
7	152004	2	5/16-18 Hex Nut
8	150108	2	#8-32 x 3/4" Phillips Pan Head Machine Screw
9	132400	1	Impellor Contactor (208/230/240v – 50/60 Hz)
10	151001	4	#8-32 Pal Nut
11	322807	1	Contacting Mounting Plate ONLY
12	150108	4	#8-32 x 3/4" Phillips Pan Head Machine Screw
13	132404	1	Reversing Contactor (208v – 50/60 Hz)
	132401	1	Reversing Contactor (240v – 50/60 Hz)
14	132416	1	Reversing Contactor Replacement Coil (208v – 60 Hz)
	132415	1	Reversing Contactor Replacement Coil (240v – 60 Hz)
	132407	1	Reversing Contactor Replacement Coil (240v – 50 Hz)
15	151001	4	#8-32 Pal Nut

Air-Operated Steam Damper Assembly

For Models Mfd. as of October 1, 1991

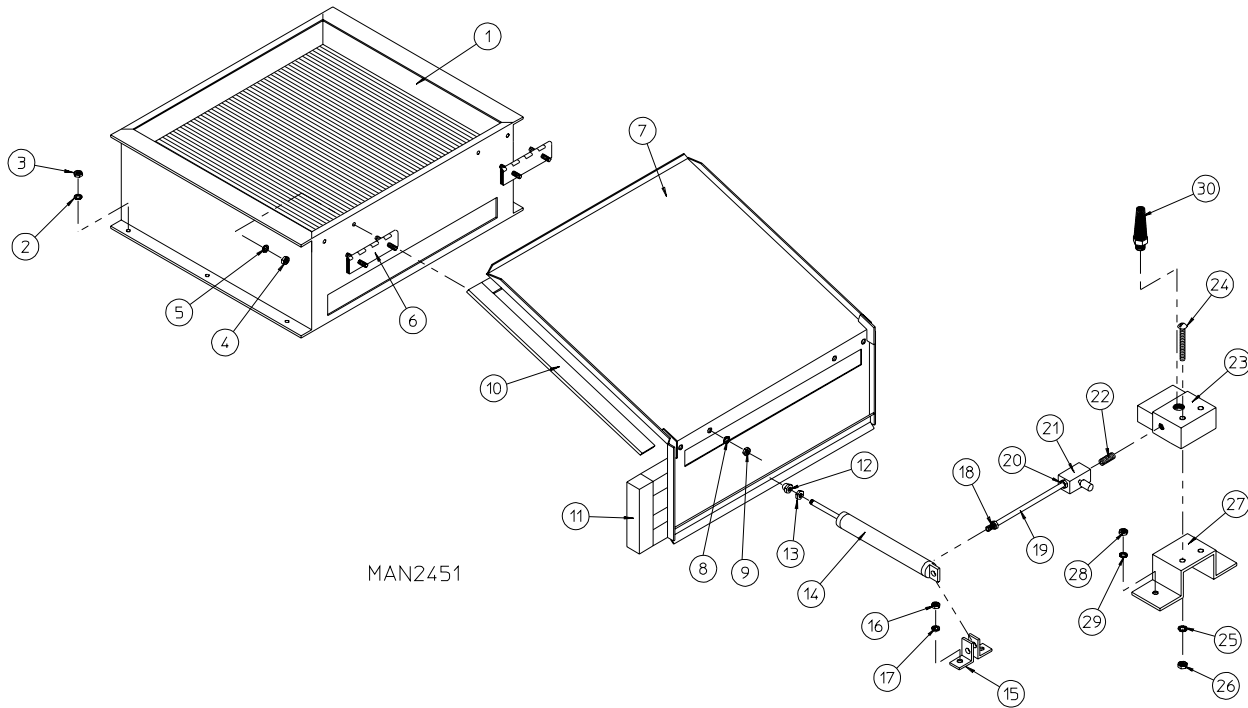

Illus. No.	Part No.	Qty.	Description
1	165009	1	Steam Coil Assembly
2	153002	6	5/16" Lock Washer
3	152004	6	5/16-18 Hex Nut
4	152002	4	1/4-20 Hex Nut
5	153007	4	1/4" Lock Washer
6	820321	2	Steam Damper Hinge Assembly
7	803415	1	Steam Damper Assembly (includes illus. nos. 7, 10, and 11)
8	153007	4	1/4" Lock Washer
9	152002	4	1/4-20 Hex Nut
10	115995	108	Steam Damper Gasket (sold by the inch)
11	102350	1	Steam Damper Foam (68-1/2" length)
12	151007	1	7/16-20 Stainless Steel Acorn Nut
13	152007	1	7/16-20 Hex Nut
14	100497	1	1-1/4" Bore x 3" Stroke Piston
15	100492	1	Piston Support Bracket
16	152002	4	1/4-20 Hex Nut
17	153007	4	1/4" Lock Washer
18	100472	1	1/4" x 1/8" Connector
19	143110	1	1/4" Tubing (sold by the foot)
20	100472	1	1/4" x 1/8" Connector
21	100496	1	1/8" Needle Valve
22	143238	1	1/8" Close Nipple
23	100498	1	3-Way Micro Valve – 24 VAC
24	150002	2	#6-32 x 1" Slotted Machine Screw
25	153010	2	#6 Star Washer
26	152000	2	#6-32 Hex Nut
27	330987	1	Micro Valve Support Bracket
28	152002	2	1/4-20 Hex Nut
29	153007	2	1/4" Lock Washer
30	100520	1	1/8" N.P.T. Silencer (muffler)

Motorized or Solenoid Steam Valve / Coil Assembly

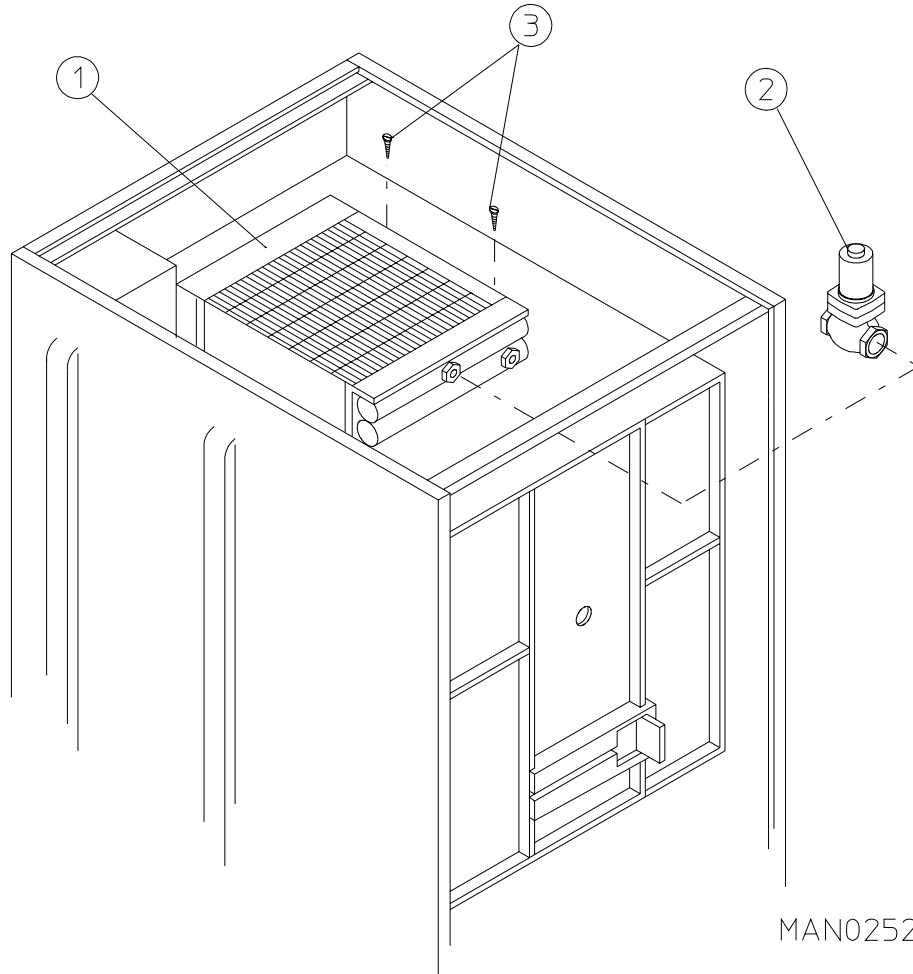

<u>Illus. No.</u>	<u>Part No.</u>	<u>Qty.</u>	<u>Description</u>
1	165002	1	Large High Pressure Steam Coil
	165003	1	Large Low Pressure Steam Coil
2	165107	1	1" Motorized Steam Valve (for high pressure steam models Only)
	165102	1	1-1/4" Steam Valve – 120 Volt (for high pressure steam models Only)
	165103	1	1-1/4" Steam Valve – 230 Volt (for high pressure steam models Only)
3	150300	4	#10-16 x 1/2" Hex Washer TEK Screw

Motorized Steam Valve Step Down Transformer

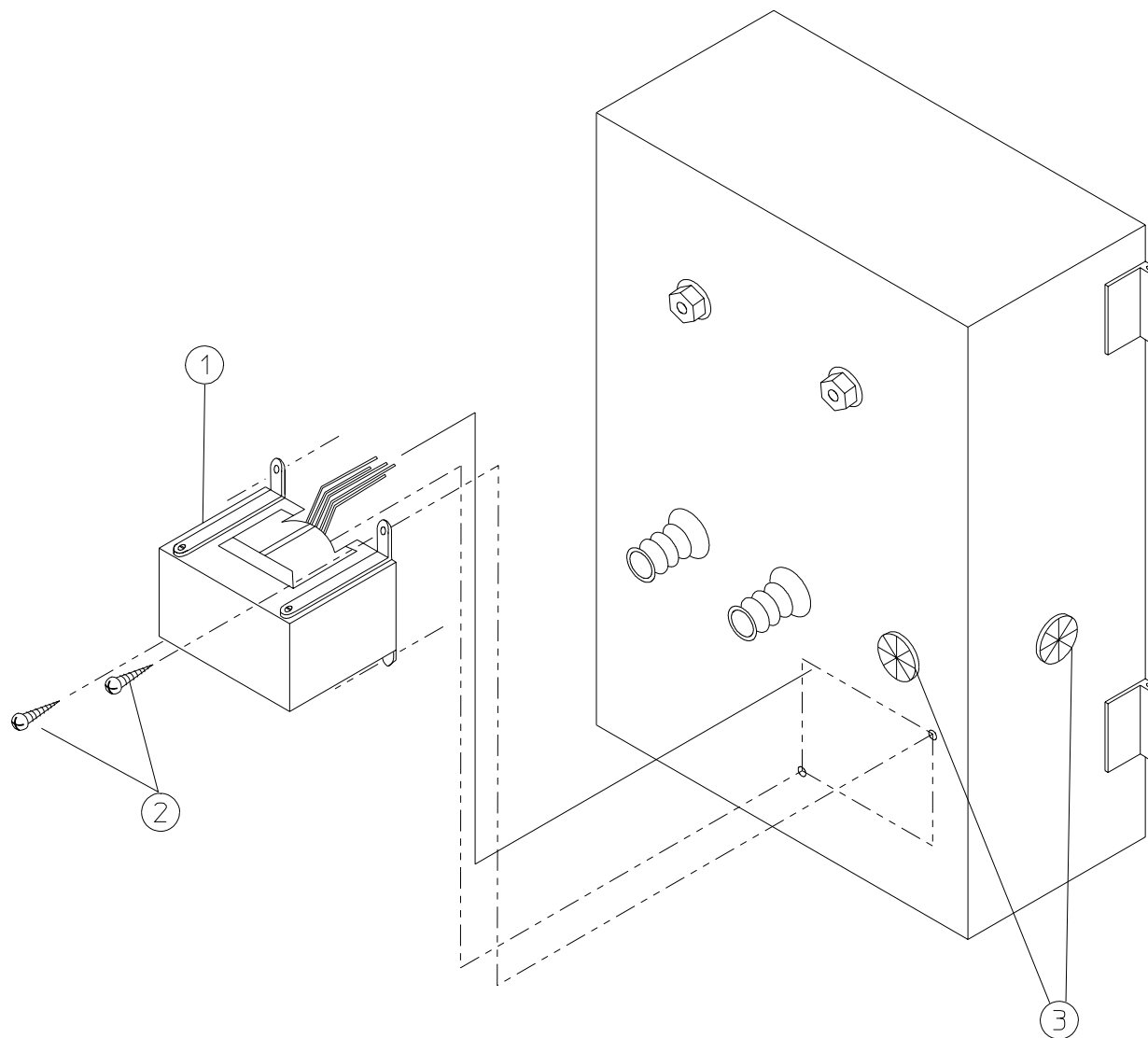

MAN0206

Illus. No.	Part No.	Qty.	Description
1*	132002	1	200 Watt Transformer (terminals not included) – 120 Volt
	880210	1	Terminal Package for Transformer
2	150309	2	#10-16 x 1/2" Hex Head TEK Crimptite Screw
3	121400	2	Universal Bushing

* Used on 208/230v control, high pressure steam models ONLY.

Outer Top / Back Guard Assemblies

For Gas and Electric Models ONLY

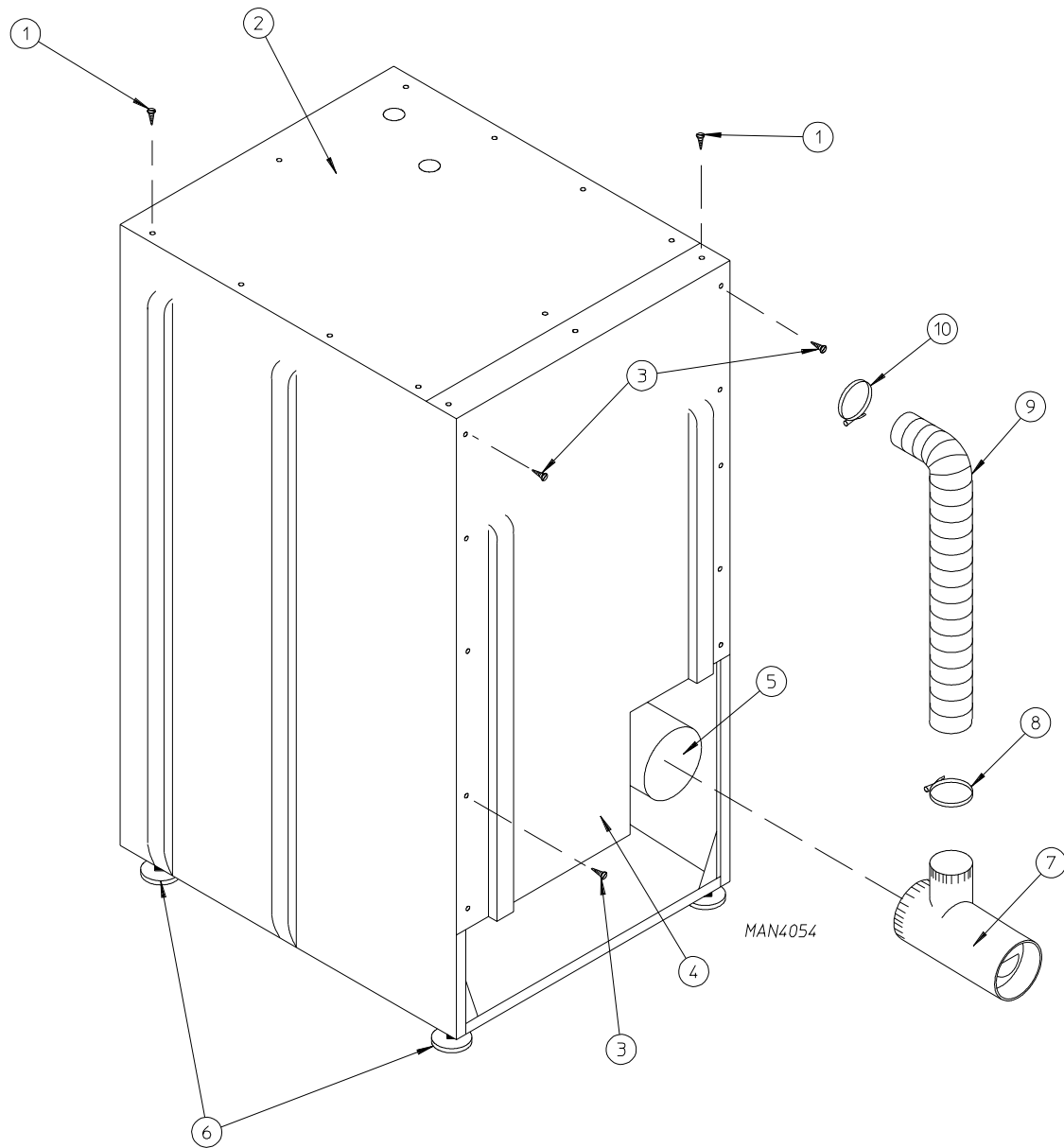

Illus. No.	Part No.	Qty.	Description
1	150301	12	#8-18 x 7/16" Phillips Pan Head TEK Screw
2	312527	1	Outer Top Guard
3	150301	8	#8-18 x 7/16" Phillips Pan Head TEK Screw
4	314507	1	Back Guard (for non-reversing models Only)
	314508	1	Back Guard (for reversing models Only)
5	880501	1	8" Damper Replacement (for non-heat reclaimers models Only)
6	103500	4	Leveling Leg
7	880511	1	8" x 8" x 3" Tee Assembly with Damper (for heat reclaimers models Only)
8	143542	1	3" Hose Clamp (for heat reclaimers models Only)
9	143543	1	3" x 8' Flexible Exhaust (for heat reclaimers models Only)
	117505	*	Aluminum Duct Tape (sold by the foot)
10	143542	1	3" Hose Clamp (for heat reclaimers models Only)

* As required.

Back Guard Assembly

For Steam Models ONLY

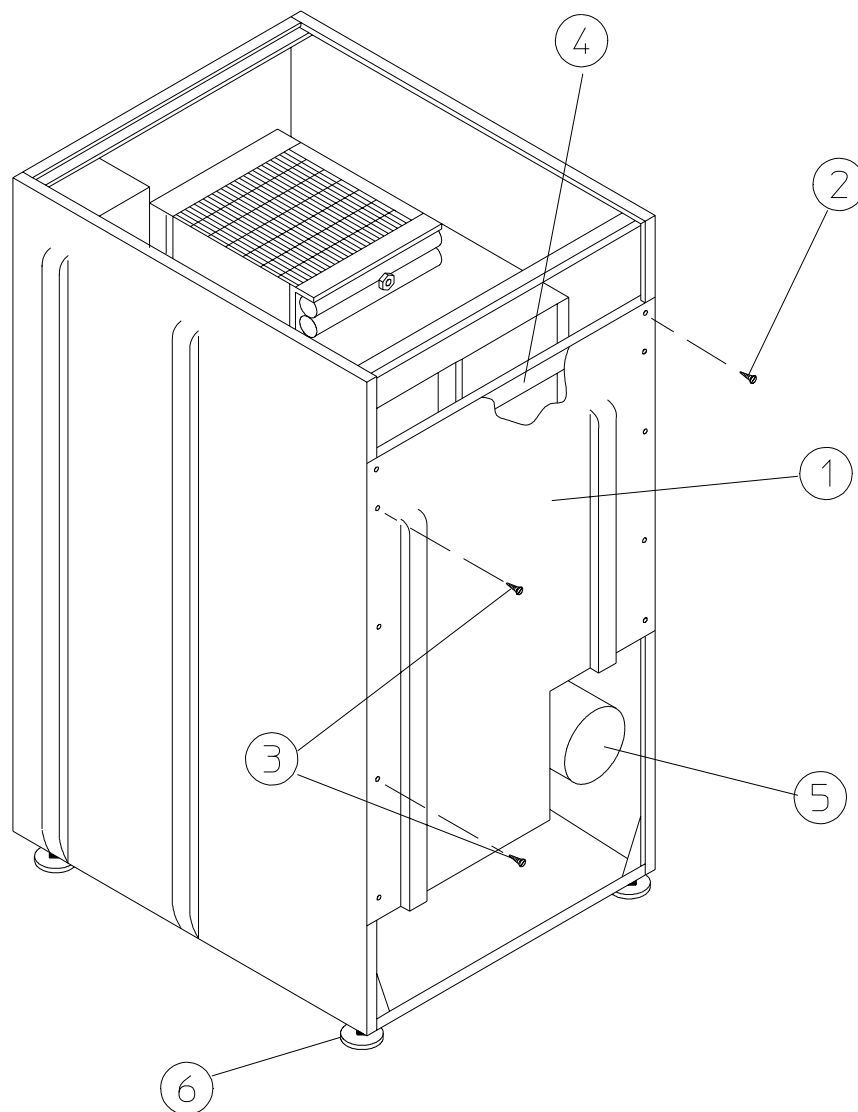

MAN0248

Illus. No.	Part No.	Qty.	Description
1	314511	1	Bottom Back Guard
2	150300	2	#10 x 1/2" Hex Washer TEK Screw
3	150301	8	#8-18 x 7/16" Phillips Pan Head TEK Screw
4	322809	1	Rear Electrical Box Cover
5	880501	1	8" Damper Replacement
			(for motorized steam valve and solenoid steam valve models Only)
	104003	1	10" Damper Replacement
			(for air-operated steam damper models Only)
	117505	*	Aluminum Duct Tape (sold by the foot)
6	103500	4	Leveling Leg

* As required.

Electric Oven Component Application Chart

For Models Mfd. as of November 12, 1990

kW	Voltage	Phase	Wire	Oven Assembly * Part No.	Element			Oven Wire with Crimp Terminal			Terminal Lug		Bus Bar Part No. 121011	Oven Relay		Relay Coil Part No.
					Qty.	kW	Part No.	Qty.	Size	Part No.	Qty.	Part No.		Cat. No.	Part No.	
36	208	3ø	3	815109	6	6	120015	4	#4	133300	5	121012	1	GEAG	131312	131811
36	208	3ø	4	815110	6	6	120015	3	#4	133300	5	121012	1	GEAF	131320	131810
36	416	3ø	3 or 4	815109	6	6	120015	4	#4	133300	3	121012	1	CEAG	131303	131809
36	230	3ø	3	815108	6	6	120014	4	#4	133300	3	121012	1	FEAG	131309	131811
36	460/480	3ø	3 or 4	815108	6	6	120014	5	#4	133300	3	121012	1	CEAG	131303	131809
33	380	3ø	3 or 4	815111	6	6	120015	4	#4	133300	3	121012	1	CEAG	131303	131809
30	208	3ø	3	815106	6	5	120012	6	#6	133200	7	121010	1	FEAG	131309	131811
30	208	3ø	4	815106	6	5	120012	6	#6	133200	7	121010	1	FEAF	131308	131810
30	230	3ø	3	815306	6	5	120013	3	#4	133300	3	121012	1	EEAG	131307	131809
30	416	3ø	3 or 4	815603	6	5	120012	4	#8	133100	5	121010	2	CEAG	131303	131809
30	460/480	3ø	3 or 4	815703	6	5	120013	4	#8	133100	5	121010	2	BEAG	131311	131809
25	380	3ø	3 or 4	815403	6	5	120012	4	#8	133100	5	121010	2	BEAG	131311	131809
24	208	3ø	3	815104	6	4	120010	3	#4	133300	3	121012	1	EEAG	131307	131809
24	208	3ø	4	815104	6	4	120010	3	#4	133300	3	121012	1	EEAF	131306	131808
24	230	3ø	3	815304	6	4	120011	3	#6	133200	3	121012	1	DEAG	131305	131809
24	416	3ø	3 or 4	815602	6	4	120010	4	#8	133100	5	121010	2	BEAG	131311	131809
24	460/480	3ø	3 or 4	815702	6	4	120011	4	#10	133000	5	121010	2	BEAG	131311	131809
20	208	1ø	2	815003	5	4	120010	2	#4	133300	2	121012	2	GEAG	131312	131811
20	230	1ø	2	815203	5	4	120011	2	#4	133300	2	121012	2	FEAG	131309	131811
20	380	3ø	3 or 4	815402	6	4	120010	4	#10	133000	5	121010	2	BEAG	131311	131809

* Oven assembly complete does not include oven relay or terminal block. These items must be ordered separately. When ordering oven assembly complete, specify 3- or 4-wire when applicable, as well as if the dryer has microprocessor (computer) or non-computer controls.

Electric Oven Component Application Chart

For Models Mfd. prior to November 12, 1990

kW	Voltage	Phase	Wire	Oven Assembly * Part No.	Element			Oven Wire with Crimp Terminal			Terminal Lug		Bus Bar Part No. 121011	Terminal Block Part No. 120704	Oven Relay		Relay Coil Part No.
					Qty.	kW	Part No.	Qty.	Size	Part No.	Qty.	Part No.			Cat. No.	Part No.	
36	208	3ø	3	* Refer to Electric Oven Component Application Chart on the previous page.	6	6	120015	5	#8	133100	6	121010	1	1	GEAG	131312	131811
36	208	3ø	4		6	6	120015	5	#8	133100	6	121010	1	1	GEAF	131320	131810
36	416	3ø	3 or 4		6	6	120015	5	#8	133100	6	121010	1	—	DEAG	131305	131809
36	230	3ø	3		6	6	120014	5	#8	133100	6	121010	1	1	FEAG	131309	131811
36	460/480	3ø	3 or 4		6	6	120014	5	#8	133100	6	121010	1	—	CEAG	131303	131809
33	380	3ø	3 or 4		6	6	120015	5	#8	133100	6	121010	1	—	DEAG	131305	131809
30	208	3ø	3		6	5	120012	5	#6	133200	6	121010	1	1	DEAG	131305	131809
30	208	3ø	4		6	5	120012	5	#6	133200	6	121010	1	1	DEAF	131304	131808
30	230	3ø	3		6	5	120013	5	#8	133100	6	121010	1	1	CEAG	131303	131809
30	416	3ø	3 or 4		6	5	120012	3	#8	133100	3	121010	2	—	CEAG	131303	131809
30	460/480	3ø	3 or 4		6	5	120013	3	#8	133100	3	121010	2	—	BEAG	131311	131809
25	380	3ø	3 or 4		6	5	120012	3	#8	133100	3	121010	2	—	BEAG	131311	131809
24	208	3ø	3		6	4	120010	5	#8	133100	6	121010	1	1	CEAG	131303	131809
24	208	3ø	4		6	4	120010	5	#8	133100	6	121010	1	1	CEAF	131302	131808
24	230	3ø	3		6	4	120011	5	#10	133300	6	121010	1	1	BEAG	131311	131809
24	416	3ø	3 or 4		6	4	120010	3	#8	133100	3	121010	2	—	BEAG	131311	131809
24	460/480	3ø	3 or 4		6	4	120011	3	#10	133000	3	121010	2	—	BEAG	131311	131809
20	208	1ø	2		5	4	120010	2	#4	133300	2	121012	2	—	GEAG	131312	131811
20	230	1ø	2		5	4	120011	2	#4	133300	2	121012	2	—	FEAG	131309	131811
20	380	3ø	3 or 4		6	4	120010	3	#10	133000	3	121010	2	—	BEAG	131311	131809

* Oven assembly complete does not include oven relay or terminal block. These items must be ordered separately. When ordering oven assembly complete, specify 3- or 4-wire when applicable, as well as if the dryer has microprocessor (computer) or non-computer controls.

<u>Part No.</u>	<u>Description</u>
112039	"Black / White / Green Ground" Label
112280	"Clean Lint Screen" Label
112534	"OPL Program Location Summary" Label
114001	"CAUTION – Exhaust / Lint Screen" Label
114006	"WARNING – Fire Hazards" Label
120100	3/8" Straight (BX) Connector
120300	3/8" x 45° (BX) Connector
120400	3/8" Red Jacket (BX) Insulator
120500	3/8" Jiffy Clip (BX Retainer Clip)
120600	3/8" Greenfield (BX)
120800	1/4" In-Line Connector
120802	Red Butt Connector
120902	#74B Wire Nut
120903	Crimp-On Wire Nut
121014	1/4" Insulated (female) Terminal
121499	5-1/2" Harness Tie
121500	8" Harness Tie
121503	Harness Tie Mounting Clip
122804	Manometer (hydro gauge) for Measuring Gas Pressure
404500	Almond Brush-In-Cap Bottle Touch-Up Paint
404502	White Brush-In-Cap Bottle Touch-Up Paint
404506	Beige Brush-In-Cap Bottle Touch-Up Paint
404507	Cornflower Blue Brush-In-Cap Bottle Touch-Up Paint
410001	1/2" Allen Wrench (for removal of shutoff valve tail piece)
880200	Electrical Terminal (assortment) Kit
882458	Tumbler Bearing Puller with Extended Arms

