



**AD-115 / 120 / 170
ML-120 / 130 / 145 / 170
Service Manual**

Phase 7 Microprocessor Controls

American Dryer Corporation
88 Currant Road
Fall River, MA 02720-4781
Telephone: (508) 678-9000 / Fax: (508) 678-9447
e-mail: techsupport@amdry.com

www.amdry.com

Retain This Manual In A Safe Place For Future Reference

American Dryer Corporation products embody advanced concepts in engineering, design, and safety. If this product is properly maintained, it will provide many years of safe, efficient, and trouble-free operation.

ONLY qualified technicians should service this equipment.

OBSERVE ALL SAFETY PRECAUTIONS displayed on the equipment or specified in the installation/operator's manual included with the dryer.

The following "FOR YOUR SAFETY" caution **must be** posted near the dryer in a prominent location.

FOR YOUR SAFETY

Do not store or use gasoline or other flammable vapors and liquids in the vicinity of this or any other appliance.

POUR VOTRE SÉCURITÉ

Ne pas entreposer ni utiliser d'essence ni d'autres vapeurs ou liquides inflammables dans le voisinage de cet appareil ou de tout autre appareil.

We have tried to make this manual as complete as possible and hope you will find it useful. **ADC** reserves the right to make changes from time to time, without notice or obligation, in prices, specifications, colors, and material, and to change or discontinue models.

Important

For your convenience, log the following information:

DATE OF PURCHASE _____ **MODEL NO.** _____

DISTRIBUTORS NAME _____

Serial Number(s) _____

Replacement parts can be obtained from your distributor or the **ADC** factory. When ordering replacement parts from the factory, you can FAX your order to **ADC** at (508) 678-9447 or telephone your orders directly to the **ADC** Parts Department at (508) 678-9000. Please specify the dryer **model number** and **serial number** in addition to the **description** and **part number**, so that your order is processed accurately and promptly.

The illustrations on the following pages may not depict your particular dryer exactly. The illustrations are a composite from the various dryer models. Be sure to check descriptions of the parts thoroughly before ordering.

“IMPORTANT NOTE TO PURCHASER”

Information must be obtained from your local gas supplier on the instructions to be followed if the user smells gas. These instructions must be posted in a prominent location near the dryer.

IMPORTANT

YOU MUST DISCONNECT AND LOCKOUT THE ELECTRIC SUPPLY AND THE GAS SUPPLY OR THE STEAM SUPPLY BEFORE ANY COVERS OR GUARDS ARE REMOVED FROM THE MACHINE TO ALLOW ACCESS FOR CLEANING, ADJUSTING, INSTALLATION, OR TESTING OF ANY EQUIPMENT PER OSHA (Occupational Safety and Health Administration) STANDARDS.

FOR YOUR SAFETY

DO NOT STORE OR USE GASOLINE OR OTHER FLAMMABLE VAPORS AND LIQUIDS IN THE VICINITY OF THIS OR ANY OTHER APPLIANCE.

DO NOT DRY MOP HEADS IN THE DRYER.

DO NOT USE DRYER IN THE PRESENCE OF DRY CLEANING FUMES.

CAUTION

DRYERS SHOULD NEVER BE LEFT UNATTENDED WHILE IN OPERATION.

WARNING

CHILDREN SHOULD NOT BE ALLOWED TO PLAY ON OR NEAR THE DRYERS.

CHILDREN SHOULD BE SUPERVISED IF NEAR DRYER(S) IN OPERATION.

WARNING

The dryer *must never be* operated with any of the back guards, outer tops, or service panels removed. PERSONAL INJURY OR FIRE COULD RESULT.

WARNING

DRYER MUST NEVER BE OPERATED WITHOUT THE LINT FILTER OR SCREEN IN PLACE, EVEN IF AN EXTERNAL LINT COLLECTION SYSTEM IS USED.

IMPORTANT

PLEASE OBSERVE ALL SAFETY PRECAUTIONS displayed on the equipment and specified in the installation manual included with the dryer.

The wiring diagram for the dryer is located in the front electrical control box area.

WARNING

DO NOT place articles on or against this appliance.

Table Of Contents

SECTION I

IMPORTANT INFORMATION..... 3

- A. Safety Precautions 3

SECTION II

ROUTINE MAINTENANCE..... 4

- A. Cleaning 4
- B. Adjustments 5
- C. Lubrication 5

SECTION III

INSTALLATION REQUIREMENTS..... 6

- A. Enclosure Air Supply and Exhaust Requirements 6
- B. Electrical and Gas Requirements 7
- C. Operational Service Check Procedure 7

SECTION IV

DESCRIPTION OF PARTS 9

- A. Control Panel (Microprocessor) 9
- B. Control Box (Computer Controls) 9
- C. Main Door Switch 9
- D. Lint Drawer Switch 10
- E. Lint Drawer 10
- F. Basket (Tumbler) 10
- G. Basket (Tumbler) Bearing and Pulley Arrangement 11
- H. Idler Bearing 11
- I. Drive Motor and Blower Motor 11
- J. Temperature Sensor (Computer Controls) 12
- K. Gas Burner 12
- L. Steam Damper System 12
- M. Compressed Air Requirements 13
- N. Electric Oven 13
- O. Sail Switch (Electric and Gas Models) 13
- P. Motor Contactor (1 ϕ Motor) 14
- Q. Non-Reversing Contactor (3 ϕ Motor) 14
- R. Reversing Relay Panel 14
- S. Hi-Limit Thermostat (Gas and Electric Models Only) 15

SECTION V

SERVICING	16
A. Controls (Computer)	16
B. Burner Controls (Gas)	19
C. Steam Controls	24
D. Electrical Oven Controls	27
E. Thermostats and Temperature Sensor	28
F. Sail Switch Assembly (Gas and Electric Models)	29
G. Front Panel and Main Door Assemblies	30
H. Basket (Tumbler) and Bearing Assembly	33
I. Idler and Bearing Assembly	35
J. Drive Pulley	36
K. Basket (Tumbler)	36
L. V-Belts	39
M. Motor	40
N. Impellor (Fan)	40
O. Lint Drawer Screen	41

SECTION VI

TROUBLESHOOTING	42
------------------------------	-----------

SECTION VII

DATA LABEL INFORMATION	56
A. Data Label	56
B. Using A Manometer	58
C. Keyboard (touch pad) Layout	59
D. Sensor Activated Fire Extinguishing (S.A.F.E.) System Theory of Operation	60
E. Static Pressure	61
F. Using A Magnehelic	62

SECTION I

IMPORTANT INFORMATION

A. SAFETY PRECAUTIONS

1. **DO NOT** store or use gasoline or other flammable vapors and liquids in the vicinity of this or any appliance.
2. Purchaser and user should consult the local gas supplier for proper instructions to be followed in the event the user smells gas. The instructions **should be** posted in a prominent location.
3. Dryers **must be** exhausted to the outdoors.
4. Although **ADC** produces a very versatile dryer, there are some articles that, due to fabric composition or cleaning method, **should not be** dried in it.



WARNING: Dry only water washed fabrics. **DO NOT** dry articles spotted or washed in dry cleaning solvents, a combustible detergent or “all purpose” cleaners. **EXPLOSION COULD RESULT.**



WARNING: DO NOT dry rags or articles coated or contaminated with gasoline, kerosene, oil, paint, or wax. **EXPLOSION COULD RESULT.**



WARNING: DO NOT dry mop heads. Contamination by wax or flammable solvents will create a fire hazard.



WARNING: DO NOT use heat for drying articles that contain plastic, foam, sponge rubber, or similarly textured rubber materials. Drying in a heated basket (tumbler) may damage plastics or rubber and may be a fire hazard.

5. A program **should be** established for the inspection and cleaning of the lint in the burner area and exhaust ductwork. The frequency of inspection and cleaning can best be determined from experience at each location.



WARNING: THE COLLECTION OF LINT IN THE BURNER/OVEN AREA AND EXHAUST DUCTWORK CAN CREATE A POTENTIAL FIRE HAZARD.

6. For personal safety, the dryer **must be** electrically grounded in accordance with local codes and/or the National Electrical Code ANSI/NFPA NO. 70-LATEST EDITION or in Canada, the Canadian Electrical Codes Parts 1 & 2 CSA C22.1-1990 or LATEST EDITION.
7. **UNDER NO CIRCUMSTANCES** should the dryer door switch or heat circuit safety devices ever be disabled.



WARNING: PERSONAL INJURY OR FIRE COULD RESULT.

8. **READ AND FOLLOW ALL CAUTION AND DIRECTION LABELS ATTACHED TO THE DRYER.**



WARNING: Children **should not be** allowed to play on or near the dryer(s). Children **should be** supervised if near dryer(s) in operation.

SECTION II

ROUTINE MAINTENANCE

A. CLEANING

A program and/or schedule **should be** established for periodic inspection, cleaning, and removal of lint from various areas of the dryer, as well as throughout the ductwork system. The frequency of cleaning can best be determined from experience at each location. Maximum operating efficiency is dependent upon proper air circulation. The accumulation of lint can restrict this airflow. If the guidelines in this section are met, an **ADC** dryer will provide many years of efficient, trouble free, and most importantly safe operation.



WARNING: LINT FROM MOST FABRICS IS HIGHLY COMBUSTIBLE. THE ACCUMULATION OF LINT CAN CREATE A POTENTIAL FIRE HAZARD.



IMPORTANT: Dryer produces combustible lint and *must be* exhausted to the outdoors. Every 6 months, inspect the exhaust ducting and remove any lint build up.

SUGGESTED CLEANING SCHEDULE

DAILY

Clean lint from the lint screen. Inspect and replace if torn.

90 DAYS

Remove lint accumulation from lint chamber thermostats and sensors. Remove lint from the motor air vents and surrounding area.



WARNING: TO AVOID THE HAZARD OF ELECTRICAL SHOCK, DISCONTINUE ELECTRICAL SUPPLY TO THE DRYER.



IMPORTANT: Lint accumulation will restrict internal motor airflow, causing overheating and irreparable motor damage. Motor failure due to lint accumulation will VOID THE WARRANTY.

120 DAYS

On gas and electric models, remove lint from gas burner area with a dusting brush or vacuum cleaner attachment. On steam dryers, clean coil. Proper cleaning of the steam coil is necessary to prevent lint build up between the fins. When cleaning the coil, be extremely careful not to bend the aluminum fins, which will also reduce airflow. If the fins are bent, straighten them by using a comb. Fin combs are available from local air conditioning supply houses. Regular cleaning will prevent lint build up and blockage of the coil.

6 MONTHS

Inspect and remove lint accumulation in the customer furnished exhaust ductwork system. Inspect exhaust draft dampers to insure they are not binding. Inspect and remove **ALL** lint accumulation from in and around control box area including coin acceptors. Clean lint accumulation from around basket (tumbler) wrapper area.



IMPORTANT: THE ACCUMULATION OF LINT IN THE EXHAUST DUCTWORK CAN CREATE A POTENTIAL FIRE HAZARD.

AS REQUIRED

In the cleaning and care of the cabinet, avoid using harsh abrasives. A product intended for the cleaning of appliances is recommended.

B. ADJUSTMENTS

7 DAYS AFTER INSTALLATION AND EVERY 6 MONTHS THEREAFTER

Inspect bolts, nuts, screws (bearing setscrews), nonpermanent gas connections, and grounding connections (unions, shutoff valves, and orifices). Motor and drive belts **should be** examined. Cracked or seriously frayed belts **should be** replaced. Tighten loose V-belts when necessary, and check belt alignment. Complete operational check of controls and valves. Complete operational check of **ALL** safety devices (door switches, sail switch, burner and lint chamber thermostats).



NOTE: V-belts ***should be*** replaced in matched pairs.

C. LUBRICATION

The motor bearings, idler bearings and basket (tumbler) bearings are permanently lubricated, and no lubrication is necessary.

SECTION III

INSTALLATION REQUIREMENTS

Installation **should be** performed by competent technicians in accordance with local and state codes. In the absence of these codes, the installation **must conform** to applicable American National Standards: ANSI Z223.1-LATEST EDITION (National Fuel Gas Code) or ANSI/NFPA NO. 70-LATEST EDITION (National Electrical Code) or in Canada, the installation **must conform** to applicable Canadian Standards: CAN/CGA-B149.1-M91 (Natural Gas) or CAN/CGA-B149.2-M91 (Liquid Propane [L.P.] Gas) or LATEST EDITION (for General Installation and Gas Plumbing) or Canadian Electrical Codes Parts 1 & 2 CSA C22.1-1990 or LATEST EDITION (for Electrical Connections).

A. ENCLOSURE, AIR SUPPLY, AND EXHAUST REQUIREMENTS



NOTE: The following information is very brief and general. For a detailed description refer to the installation booklet for OPL dryers.

Bulkheads and partitions around the dryer **should be** made of noncombustible materials. Allowances **should be** made for the opening and closing of the control door and lint door. Also, allowances **should be** made in the rear for ease of maintenance. (Refer to installation manual for recommended distances and minimum allowances required.)

When the dryer is operating, it draws in room air, heats it, passes the air through the basket (tumbler), and exhausts it out the building. Therefore, the room air **must be** continually replenished from the outdoors. If the make-up air is inadequate, drying time and drying efficiency will be adversely affected. Ignition problems and sail switch “fluttering” problems on gas dryers may result, and you also could have premature motor failure from overheating. On electric dryers, premature electric element failure may result. Air supply **must be** given careful consideration to insure proper performance of each dryer.



IMPORTANT: Make-up air **must be** provided from a source free of dry cleaning solvent fumes. Make-up air that is contaminated by dry cleaning solvent fumes will result in irreparable damage to the motors and other dryer components.

Exhaust ductwork **should be** designed and installed by a qualified professional. Improperly sized ductwork will create excessive back pressure, which will result in slow drying, increased use of energy, and shutdown of the burner by the airflow (sail) switch.



CAUTION: IMPROPERLY SIZED OR INSTALLED OR MAINTAINED (CLEANED) EXHAUST DUCTWORK CAN CREATE A POTENTIAL FIRE HAZARD.

B. ELECTRICAL AND GAS REQUIREMENTS

1. Electrical Requirements

It is your responsibility to have **ALL** electrical connections made by a properly licensed and competent electrician to assure that the electrical installation is adequate and conforms to local and state regulations or codes. In the absence of such codes, **ALL** electrical connections, materials, and workmanship **must conform** to the applicable requirements of the National Electrical Code ANSI/NFPA NO. 70-LATEST EDITION or in Canada, the Canadian Electrical Codes Parts 1 & 2 CSA C22.1-1990 or LATEST EDITION.



IMPORTANT: Failure to comply with these codes or ordinances, and the requirements stipulated in this manual, can result in personal injury or component failure.

It is your responsibility to have **ALL** plumbing connections made by a qualified professional to assure that the gas plumbing installation is adequate and conforms to local and state regulations or codes. In the absence of such codes, **ALL** plumbing connections, materials, and workmanship **must conform** to the applicable requirements of the National Fuel Gas Code ANSI Z223.1-LATEST EDITION, or in Canada, the Canadian Installation Codes CAN/CGA-B149.1-M91 (Natural Gas) or CAN/CGA-B149.2-M91 (Liquid Propane [L.P.] Gas) or LATEST EDITION.

1. Gas Supply

The gas dryer installation **must meet** the American National Standard...National Fuel Gas Code ANSI Z223.1-LATEST EDITION, or in Canada, the Canadian Installation Codes CAN/CGA-B149.1 M91 (Natural Gas) or CAN/CGA-B149.2-M91 (L.P. Gas) or LATEST EDITION, as well as local codes and ordinances and **must be** done by a qualified professional.

In Australia, the fuel gas code is AS 5601/AG 601, local authority, gas, electricity, and any other relevant statutory regulations.

It is important that gas pressure regulators meet applicable pressure requirements, and that gas meters be rated for the total amount of all the appliance Btu being supplied.



NOTE: Undersized gas piping will result in ignition problems and slow drying and can create a safety hazard.

The dryer **must be** connected to the type of gas (natural or L.P.) indicated on the dryer data label. If this information does not agree with the type of gas available, **DO NOT operate the dryer**. Contact the dealer who sold the dryer or contact **ADC**.

The gas input ratings shown on the dryer data label are for elevations up to 2,000 feet (609.6 meters), unless elevation requirements of over 2,000 feet (609.6 meters) were specified at the time the dryer order was placed with the factory. The adjustment for dryers in the field for elevations over 2,000 feet (609.6 meters) are made by changing the burner orifices. If this adjustment is necessary, contact the dealer who sold you the dryer or contact **ADC**.



NOTE: Any burner changes **must be** made by a qualified technician.

C. OPERATIONAL SERVICE CHECK PROCEDURE

After performing any service or maintenance function, an operational check **should be** performed to insure that **ALL** components are performing properly.

1. Make a complete operational check of **ALL** the operating controls to assure that the timing is correct, temperature selection switches are functioning, etc.
2. Make a complete operational check of **ALL** safety related circuits, door switch(s), hi-limit thermostat, sail switch, cycling thermostats, etc.
3. On gas models, gas pressure test **should be** taken at the gas valve pressure tap of each dryer to assure that the water column (W.C.) pressure is correct and consistent.



NOTE: Water column pressure requirements (measured at the gas valve pressure tap):

Natural Gas 3.5 inches (8.7 mb) Water Column.

Liquid Propane (L.P.) Gas 10.5 inches (26.1 mb) Water Column.

4. The dryer **should be** operated through one (1) complete cycle to assure that no future adjustments are necessary and that **ALL** components are functioning properly.
5. For 3-phase (3 ϕ) motor models, check the electric service phase sequence while the dryer is operating. Check to see if the blower wheel is rotating in the proper direction. Looking from the front, the blower wheel should spin in the clockwise (CW) direction. If so, the phasing is correct. If the phasing is incorrect, reverse two (2) leads at connections L1, L2, L3 of power supply to the dryer.

SECTION IV

DESCRIPTION OF PARTS

A. CONTROL PANEL (MICROPROCESSOR)

Lifting the control door will reveal the control panel assembly. Opening the control panel will allow access to the major components, which include the computer board, and keyboard (touch pad). The keyboard (touch pad) inputs to the computer what temperature and program has been selected. The computer controls the entire operation of the dryer. It accepts inputs and gives outputs to various parts throughout the dryer.

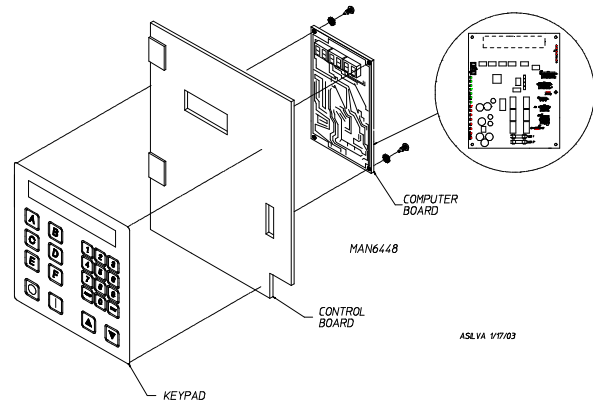

B. CONTROL BOX (COMPUTER CONTROLS)

The computer control box is made up of several computer harnesses. These harnesses provide input and output voltages to various devices throughout the dryer.

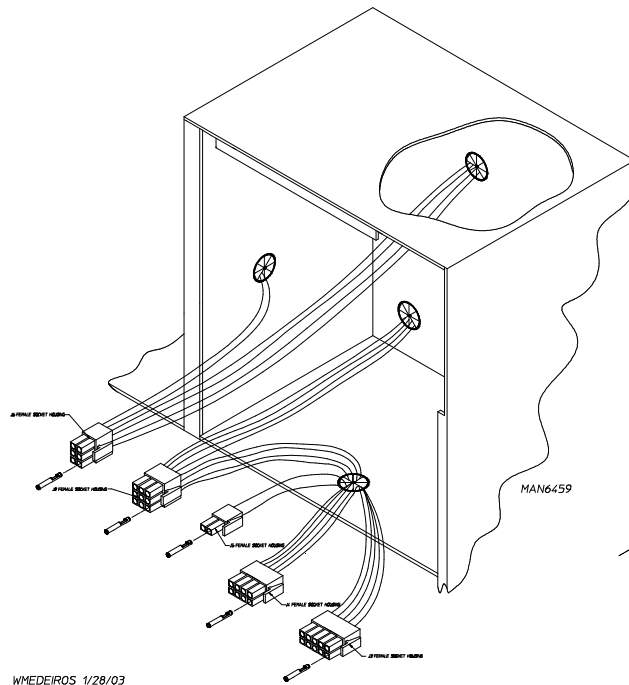

C. MAIN DOOR SWITCH

The main door switch is located behind the main door on the right hand side. When the main door is opened, the switch will also open, preventing the dryer from operating. The main door switch is a safety device and **should never be disabled**.

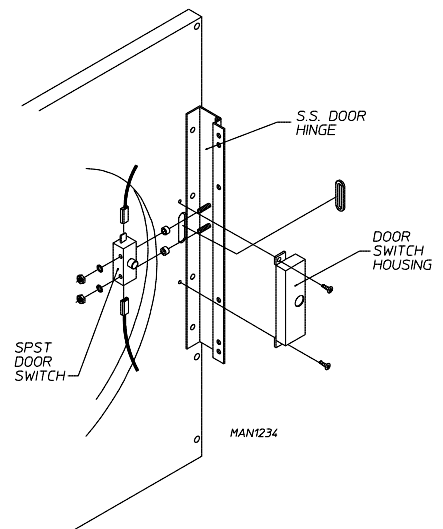

D. LINT DRAWER SWITCH

The lint drawer switch is located in the lint compartment and attached to the side of the lint drawer track. The lint drawer switch insures that the dryer will operate only when the lint drawer is completely close. This is a safety device and **should never be** disabled.

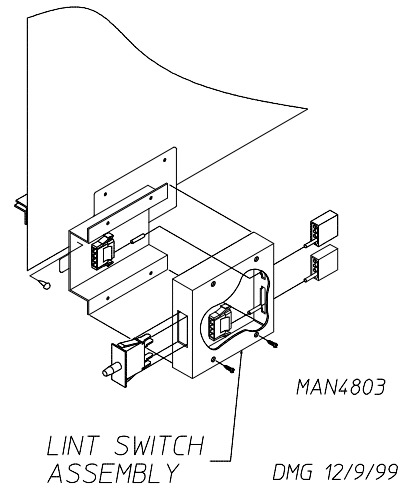

E. LINT DRAWER

The lint drawer is a pullout type and is located at the bottom of the dryer in the lint compartment. Simply grab the lint drawer handle, slide out the drawer, brush off the lint, and slide the drawer back in. The lint screen **must be** kept clean in order for the dryer to operate properly and efficiently.

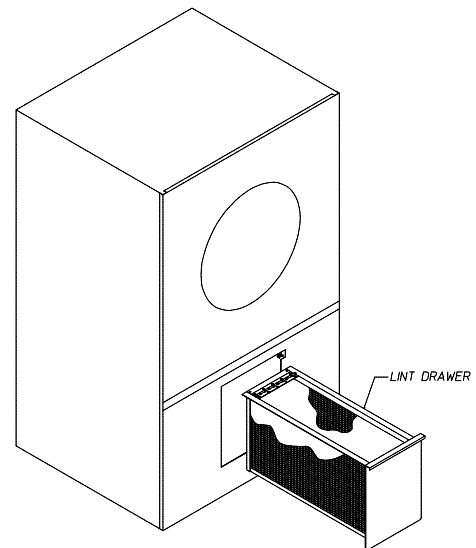

ASILVA/WM 1/28/03

MAN6467

F. BASKET (TUMBLER)

The basket (tumbler) consists of three (3) or four (4) ribs and a perforated basket (tumbler) along with a front and back, which are riveted or screwed together as an assembly. The basket (tumbler) also consists of tie rods, which support the basket (tumbler) from front to back. The basket (tumbler) support is used to mate the basket (tumbler) to the drive system in the rear. Some models also have a felt band, which helps to keep lint from accumulating behind the basket (tumbler).

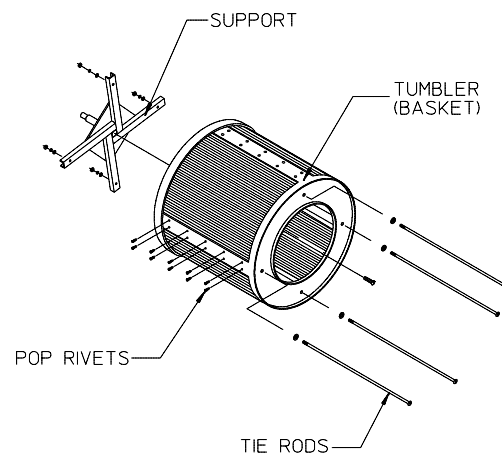

MAN0560

G. BASKET (TUMBLER) BEARING AND PULLEY ARRANGEMENT

The basket (tumbler) bearing and the pulley arrangement is located (viewing from the rear of the dryer) approximately at the upper center of the dryer. The arrangement consists of a pulley, bearing platform, and bearing, which serve to adjust, drive, and support the basket (tumbler).

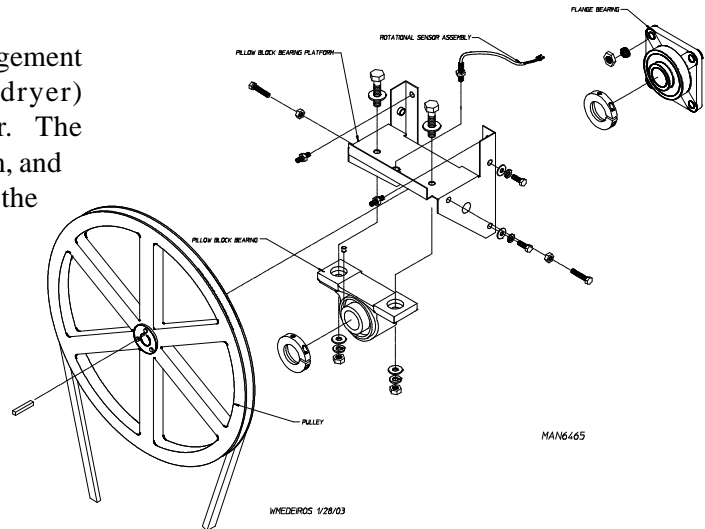

H. IDLER BEARING

Viewing from the rear of the dryer, the idler assembly is located approximately on the lower left hand side of the dryer. The idler assembly consists of one (1) compound pulley. The idler's main purpose is to reduce the speed and increase the torque, provided to the basket (tumbler) bearing. Also, the idler assembly belt tension can be adjusted. AD-15 thru AD-30 requires a 9" x 2-1/2" pulley. AD-50 thru AD-75 requires a 14" x 3" pulley.

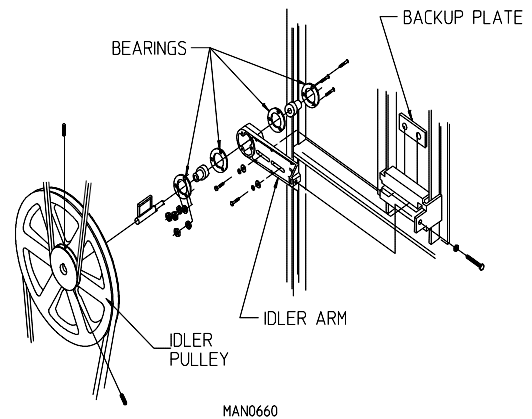

I. DRIVE MOTOR AND BLOWER MOTOR

The drive motor is located on the back, approximately lower center of the dryer. It sits on an adjustable base, so that the motor can be easily adjusted to the left or right, up or down. On non-reversing dryers, the blower end of the motor is connected to the impellor, a backward curved paddlewheel. The impellor provides airflow in the dryer. It creates a vacuum, which pulls the hot air from the burner into the basket (tumbler) through the lint screen and out the exhaust. On reversing dryers, there are two (2) motors, one (1) for the drive and one (1) for the blower.

Reversing Models

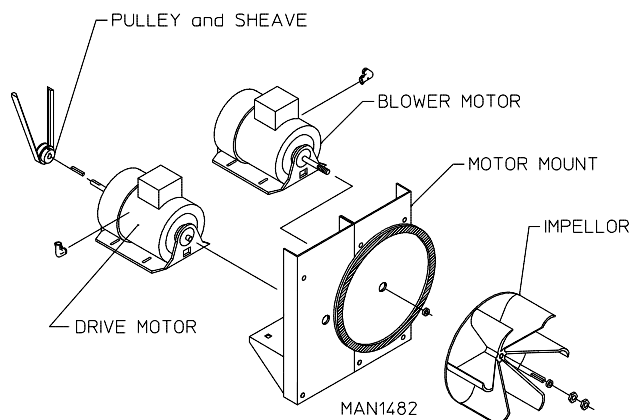

Non-Reversing Models

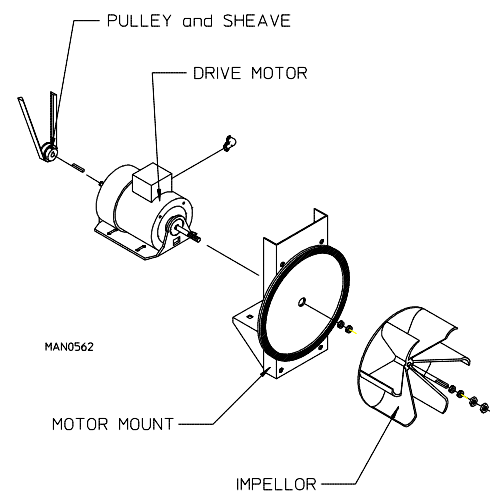

J. TEMPERATURE SENSOR (COMPUTER CONTROLS)

The temperature sensor used, is a transducer that converts heat into microamps that the computer board then uses to calculate the temperature.

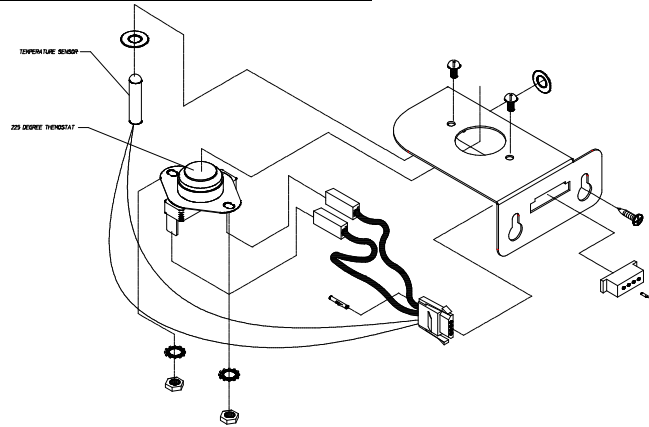

MICROPROCESSOR SENSOR BRACKET ASSEMBLY

WMEDEIROS 1/28/03

MAN6464

K. GAS BURNER

Gas dryers are equipped with a gas burner located behind the control door. The gas burner assembly consists of the burner tubes, orifices (the orifices have a hole in them to allow gas to flow through. The hole size varies with different elevations, and different BTUs), gas valve (which can be set up for natural gas or liquid propane [L.P.] gas), spark ignitor/flame-probe assembly, sail switch, and hi-limit thermostat. Gas burners will vary from model in size, shape, and relative location. Some models are equipped with heat reclaimer systems in which, some of the exhaust air is recovered and introduced back into the drying process.

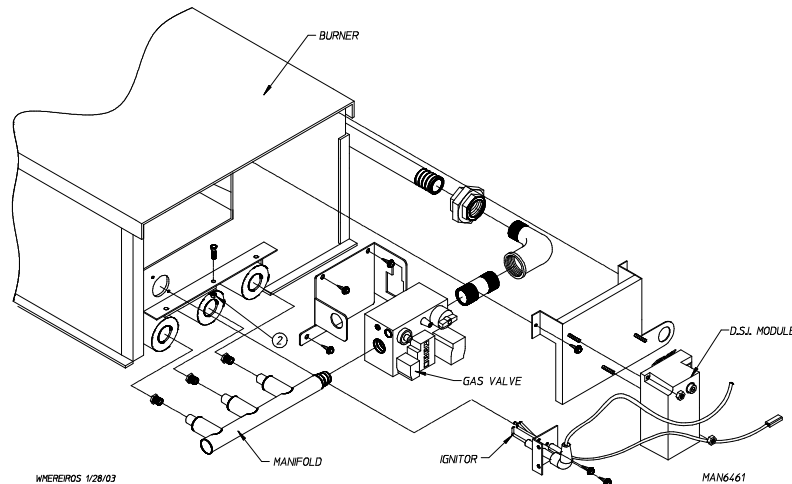

WMEDEIROS 1/28/03

MAN6461

L. STEAM DAMPER SYSTEM

The newest type system is called the steam damper. It is shown to the right and it uses a piston with compressed air to open and close the steam damper, which in turn allows the air to flow either through the coil for heat, or under the coil for cool down. Air supply is 80 PSI +/- 10 PSI (5.51 bar +/- 0.69 bar).

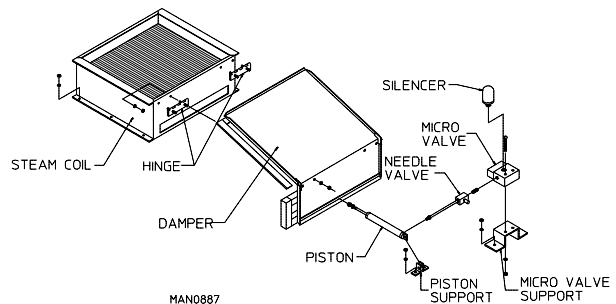

MAN0887

M. COMPRESSED AIR REQUIREMENTS

This dryer requires an external supply of air (2.5 cfm @ 80 PSI [0.07 cmm @ 5.51 bar]) on the steam models, the air is necessary to operate the steam damper system. On both steam, as well as the gas model, the air is necessary for the blower air jet operation to clean lint from the impellor/fan (squirrel cage type).

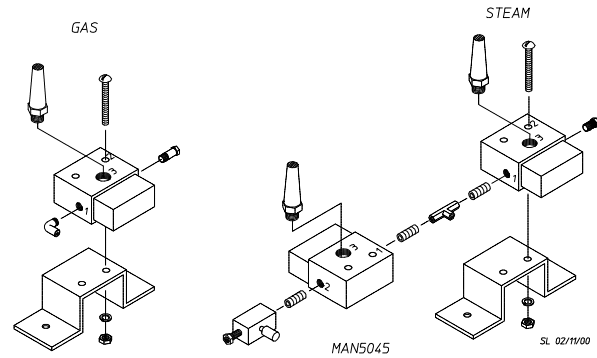

N. ELECTRIC OVEN

Electric dryers are equipped with an electric oven located behind the control door. The electric oven assembly consists of the electric oven box, contactor, and heating elements. In an electric oven, the elements heat the passing airflow entering the basket (tumbler). **ALL** ovens have Kw ratings. This is the rating of how much heat the oven can produce. The higher the rating, the more heat.

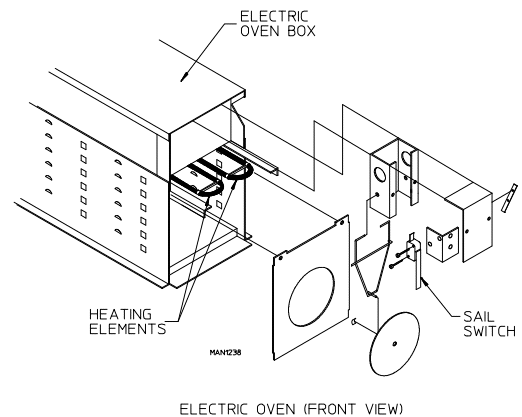

O. SAIL SWITCH (ELECTRIC AND GAS MODELS)

The sail switch consists of a round damper plate on a lever arm, which acts like an actuator for a microswitch. When the air blower comes on, it draws air through the burner. This creates a negative pressure inside the burner box, and this negative pressure pulls in the round damper, which activates the sail switch. If there is improper airflow, the damper will not pull in, preventing the burner from coming on. Improper airflow can be caused by improperly designed exhaust ducting, where the duct run is too long or has too many sharp bends on it. It can also be caused by a lack of make-up air. Sail switch is located in front of the oven on electric dryers and in the back of the burner on gas models.

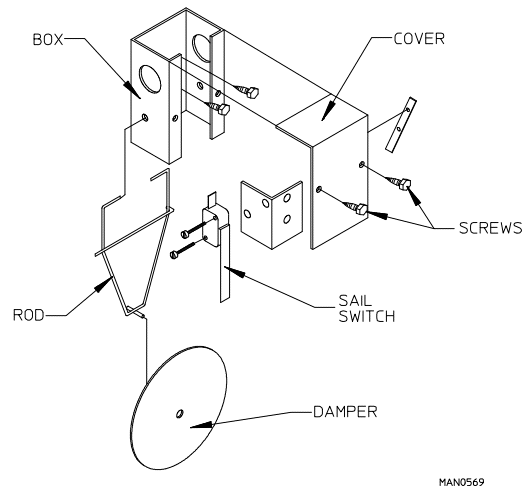

P. MOTOR CONTACTOR (1Ø MOTOR)

This motor contactor used on a single-phase (1Ø) dryer, is located in the rear of the dryer, in the electrical panel box. Its purpose is to transfer the higher voltage to the motor, when the contactor coil voltage has been achieved.

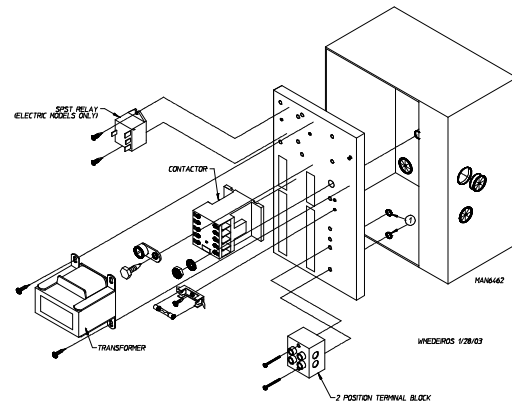

Q. NON-REVERSING CONTACTOR (3Ø MOTOR)

The non-reversing contactor is used on 3-phase (3Ø) non-reversing dryers and is located on the upper left hand side of the dryer (view from the rear). Its purpose is to transfer the higher voltage to the motor, when the contactor coil voltage has been achieved.

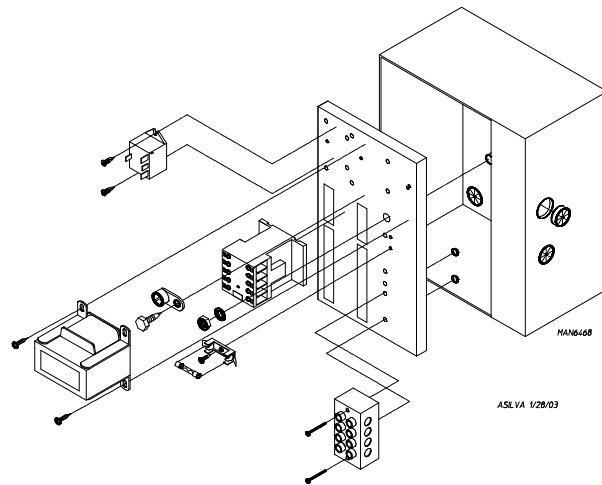

R. REVERSING RELAY PANEL

This panel is located in the back of the dryer at the upper left hand corner. On this panel is an arc suppressor (A.S.) board, which filters out “noise” that might go to the coils of the contactors. Also, mounted on this panel are the drive and blower/fan contactors. The 2-pole circuit breaker is used to protect L1 and L3 on 460-480 VAC models only. The transformer is stepping down the incoming voltage to 24 VAC, to supply the voltage to the computer and controls.

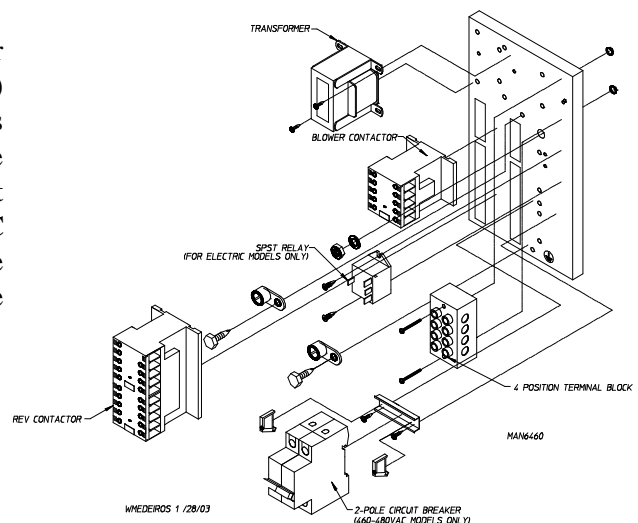

S. HI-LIMIT THERMOSTAT (GAS AND ELECTRIC MODELS ONLY)

The hi-limit thermostat is another safety device that we use on gas and electric models. The hi-limit is located in the burner or oven area. The hi-limit switch cuts off the heat, if the temperature exceeds 290° for electric models or 330° for gas models. The only way this device would shut off the heat, is when the airflow changes to the extent of making the flame brush up against it.

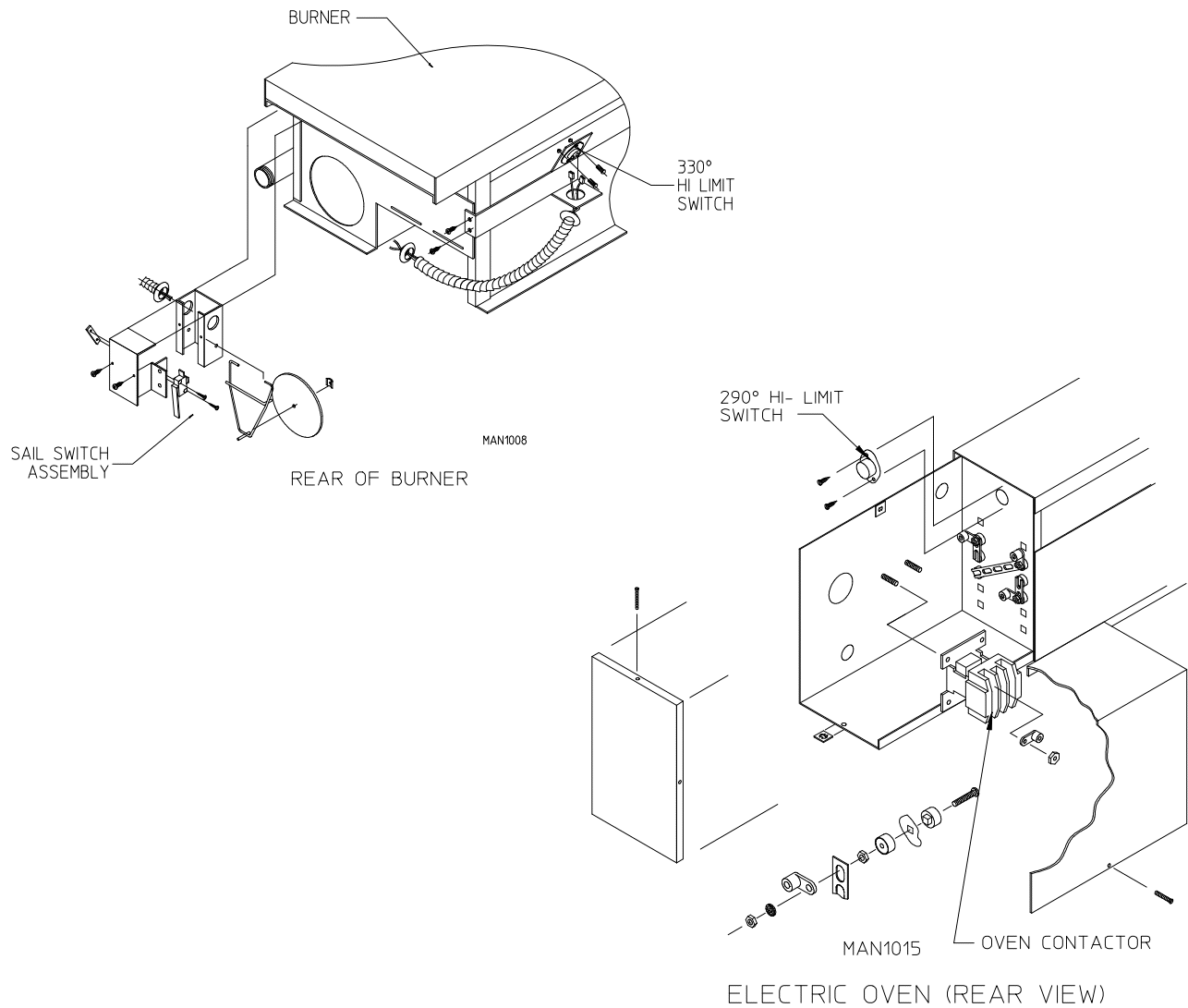

SECTION V

SERVICING

 **IMPORTANT: YOU MUST DISCONNECT AND LOCKOUT THE ELECTRIC SUPPLY AND THE GAS SUPPLY BEFORE ANY COVERS OR GUARDS ARE REMOVED FROM THE MACHINE TO ALLOW ACCESS FOR CLEANING, ADJUSTING, INSTALLATION, OR TESTING OF ANY EQUIPMENT PER OSHA (Occupational Safety and Health Administration) Standards.**

 **WARNING: PERSONAL INJURY COULD RESULT.**

The information provided in this section **should not be** misconstrued as a device for use by untrained persons making repairs. Service work **should be** performed by competent technicians in accordance with local, state, and federal codes. When contacting the factory for assistance, always have the dryer **model number** and **serial number** available.

 **CAUTION: Observe ALL safety precautions displayed on the dryer or specified in this manual before and while making repairs.**

Before considering replacement, make sure that **ALL** connectors are in place and making proper contact. Check input voltages and temperature sensor. After replacing any parts, or performing adjustments or service, run through a complete cycle.

A. CONTROLS (COMPUTER)

TO REPLACE CONTROL PANEL ASSEMBLY

1. Disconnect power to the dryer.
2. Disconnect the J3, J4, J5, J6, and J8 harnesses from rear of the computer by squeezing the top locking tabs and pulling the connector straight back.
3. Disconnect the green ground wire from the computer.
4. To remove control panel assembly from the control box, gently tap the bottom of the control panel upward and lift off the hinges.
5. Install new control panel assembly by reversing the procedure.
6. Be sure to check or reset programs.

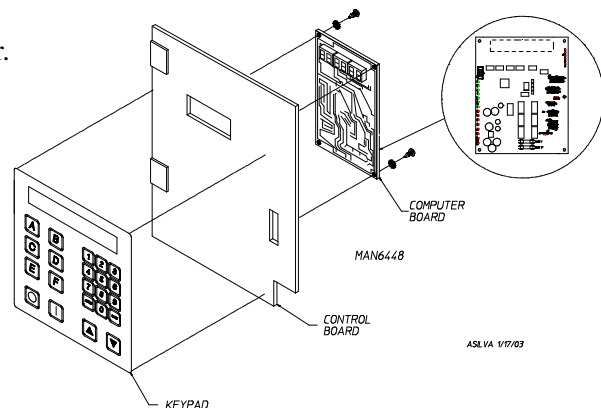



NOTE: Use caution when handling MP Controller. It can be easily damaged by static electricity.

TO REPLACE COMPUTER

1. Discontinue power to the dryer.
2. Disconnect the J3, J4, J5, J6, and J8 harnesses from the rear of the computer by squeezing the top locking tab and pulling the connector straight back.
3. Disconnect the green ground wire from the computer.
4. Disconnect the keyboard (touch pad) ribbon from the computer.
5. Remove the two (2) screws securing the computer to the control panel and remove computer from the panel, by pulling upwards on the corners.
6. Install the new computer by reversing this procedure.
7. Be sure to check or reset programs.

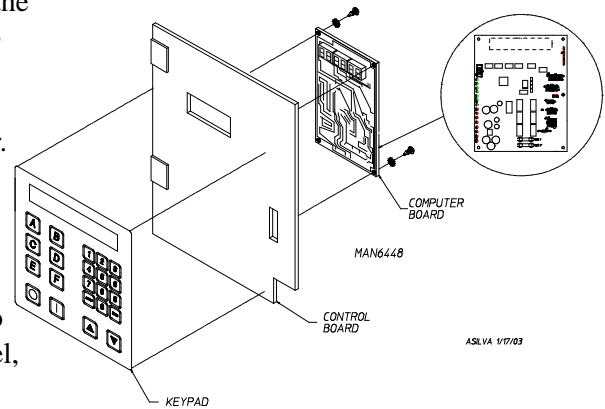

NOTE: Use caution when handling MP Controller. It can be easily damaged by static electricity.

TO REPLACE KEYBOARD (TOUCH PAD) Refer to **illustration above**

1. Discontinue power to the dryer.
2. Swing the control panel open and unplug keyboard (touch pad) ribbon from the computer board.
3. Peel the keyboard (touch pad) from the front of the control panel, taking care to avoid scratching the panel.
4. Clean any adhesive residue from the panel.
5. Peel of paper backing from new keyboard (touch pad).
6. Align the display window on the keyboard (touch pad), with the cutout in the control panel and press in place.
7. Connect keyboard (touch pad) ribbon to the board and reconnect power to the dryer.
8. Test for operation by pressing each selection (A through F).

TO REPLACE COMPUTER TEMPERATURE SENSOR PROBE

1. Discontinue power to the dryer.
2. Remove MP sensor bracket assembly from the dryer.
 - a. Disconnect sensor bracket harness connector.
 - b. Loosen the two (2) Phillips head screws securing the bracket assembly to the dryer and remove the bracket from the dryer.

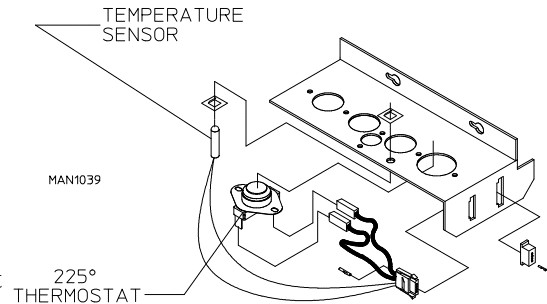

NOTE: DO NOT remove screws.

3. Disassemble the sensor probe from the bracket assembly by removing the top push on fastener securing the probe to the bracket. Use a small screwdriver to slowly pry the fastener off.
4. Disconnect the two (2) orange wires from the high heat (225°) temperature thermostat. Remove modular bracket connector, wires, and probe from the bracket assembly.
5. Install new sensor probe assembly (ADC Part No. 880251) by reversing the procedure.
6. Reestablish power to dryer.



NOTE: If, when power is reestablished the computer display reads “dSFL,” check for loose connection on the wiring.

TO REPLACE MOTOR CONTACTOR 3-POLE, 24 VAC

1. Discontinue power to the dryer.
2. Remove **ALL** wires from contactor (**NOTE:** make sure each wire is marked with location removed from).
3. Press down firmly on the contactor and shift towards the right, then pull contactor out.
4. Install the new contactor in reverse procedure.
5. Reestablish power to the dryer.

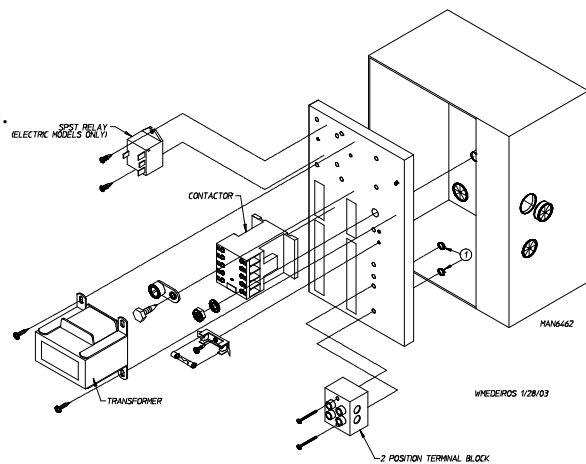

B. BURNER CONTROLS (GAS)

This illustration is typical of **ALL** gas burners, but they are not ALL exactly alike. Your particular model may have some differences.

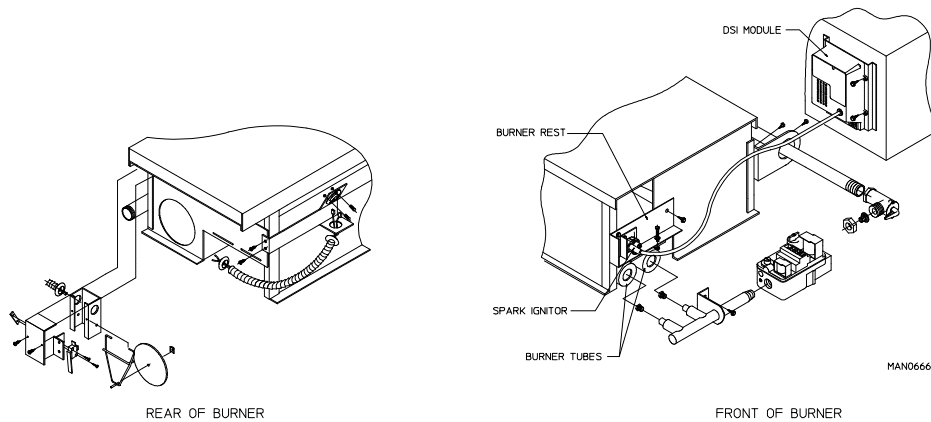

TO REPLACE SPARK IGNITOR AND FLAME SAFEGUARD

1. Discontinue power to the dryer.
2. Disconnect high voltage (HV) connector and flame-probe connection from ignitor.
3. Disassemble ignitor from burner by removing the two (2) self-tapping screws.
4. Reverse procedure for installing the new ignitor probe.

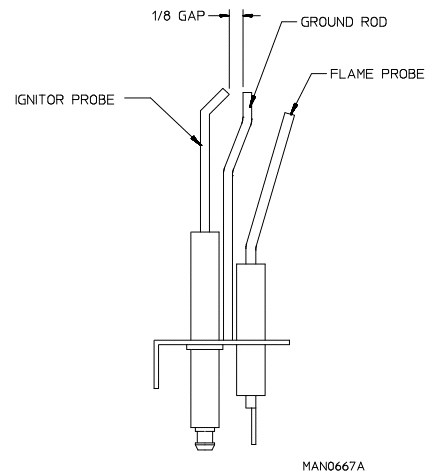

NOTE: Before reestablishing power to the dryer, visually check the following: (refer to the illustration).

5. The flame-probe, ignitor probe, and ground rod are **ALL** on the same line of axis.
6. There **should be** a 1/8" gap (+/- 1/32) between the ignitor probe and ground rod.
7. **DO NOT** wrap the red high voltage (HV) wire and flame-probe wire together. (Improper operation may result.) They may run along side each other.

TO REPLACE GAS VALVE

1. Discontinue power to the dryer.
2. Close shutoff valve in the gas supply line.
3. Disconnect the gas valve wiring.
4. Break union connection before gas valve.
5. Loosen and remove two (2) screws securing pipe bracket to the burner.
6. Remove gas valve/manifold assembly from the dryer.
7. Remove manifold from outlet of the gas valve.
8. Remove union tailpiece from valve. Use a 1/2" Allen wrench (ADC Part No. 410001).
9. Reverse procedure for installing the new gas valve.

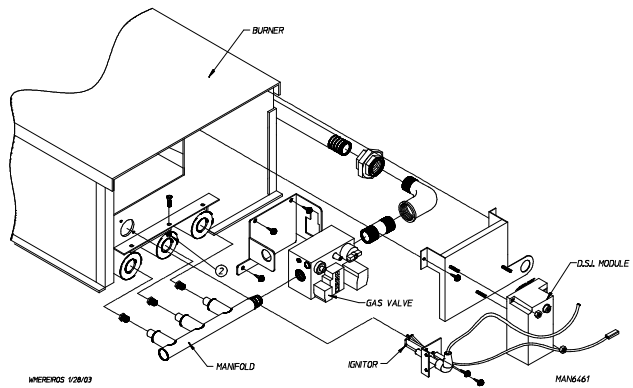

WARNING: Test ALL connections for leaks by brushing on a soapy water solution (liquid detergent works well).



WARNING: NEVER TEST FOR LEAKS WITH A FLAME!!!

TO REPLACE MAIN BURNER ORIFICES

1. Refer to "TO REPLACE GAS VALVE" and follow *Step #1 through #6*.
2. Unscrew main burner orifices and replace.



NOTE: Use extreme care when removing and replacing orifices. THESE ORIFICES ARE MADE OF BRASS, WHICH IS EASILY DAMAGED.

3. Reverse the removal procedure for reinstalling.



WARNING: Test ALL connections for leaks by brushing on a soapy water solution (liquid detergent works well).



WARNING: NEVER TEST FOR LEAKS WITH A FLAME!!!

TO TEST AND ADJUST GAS (WATER COLUMN [W.C.] PRESSURE

There are two (2) types of devices commonly used to measure water column pressure. They are spring/mechanical type gauges and manometers. The spring/mechanical type gauge is not recommended because it is easily damaged and not always accurate. A manometer is simply a glass or transparent plastic tube with a scale in inches, which when filled with water and pressure is applied, the water in the tube rises, showing the exact water column pressure.



NOTE: Manometers are available from the factory by ordering Part No. 122804.

1. To test gas water column (W.C.) pressure.
 - a. Connect water column test gauge connection to gas valve pressure tap (1/8" N.P.T.). This pressure tap is located on the outlet (downstream) side of the valve.
 - b. Start the dryer. With burner on, the correct water column reading in inches would be:

Natural Gas 3.5 Inches (8.7 mb) Water Column
 Liquid Propane (L.P.) Gas 10.5 Inches (26.1 mb) Water Column

2. To adjust water column pressure for natural gas models, remove vent cap. Turn the slotted adjustment screw located on top of the valve next to the terminals. Turn clockwise (CW) to increase manifold pressure and counterclockwise (CCW) to decrease. For L.P. gas models there is no regulator on valve.

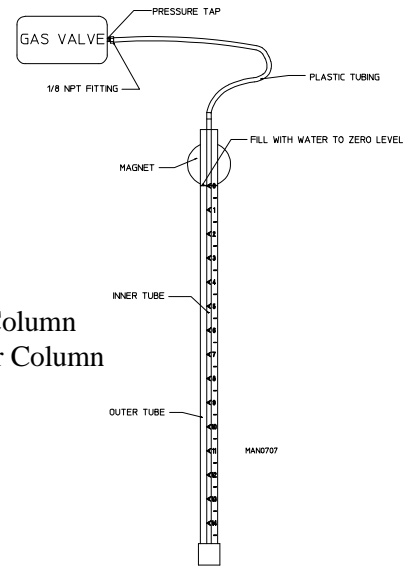

NOTE: If correct water column pressure **cannot** be achieved, problem may be due to an undersized gas supply line, a faulty or underrated gas meter, etc.

TO CONVERT FROM NATURAL TO LIQUID PROPANE (L.P.) GAS

1. Disconnect electrical power to the dryer.
2. Close **ALL** shutoff valves in dryer gas supply line.
3. Disconnect gas valve wiring.



NOTE: Identify location of each wire for correct reinstallation.

4. Break union connection (nut) between union shutoff and gas valve.
5. Loosen and remove screws from bracket holding the gas valve/manifold assembly to burner box.
6. Remove gas valve/manifold assembly from the dryer.
7. Unscrew main burner orifices and replace with L.P. orifices supplied.



NOTE: Use extreme care when removing and replacing orifices. THESE ORIFICES ARE MADE OF BRASS, WHICH IS EASILY DAMAGED.

8. To convert gas valve for use with L.P. gas, refer to instructions included in kit envelope (#F92-0737) supplied.
9. Reverse procedure for reinstalling valve manifold assembly to the dryer.



IMPORTANT: External regulation of a consistent gas pressure of between 10.5 inches (26.1 mb) water column (W.C.) ***must be*** provided.

10. Open **ALL** shutoff valves and test for leaks.



IMPORTANT: *DO NOT* test for leaks with an open flame. Use soapy water solution or product intended for that purpose.

11. Operate dryer through one (1) complete cycle to insure proper operation.



IMPORTANT: Conversion ***should be*** performed by competent technicians in accordance with local and state codes. Improper assembly or adjustments can cause hazardous condition.



NOTE: There is no regulator provided in an L.P. dryer. The water column pressure ***must be*** regulated at the source (L.P. tank), or an external regulator ***must be*** added to each dryer.



NOTE: Use extreme care when removing and replacing orifices. THESE ORIFICES ARE MADE OF BRASS, WHICH IS EASILY DAMAGED.

12. Call ADC for L.P. conversion kits or the proper orifices for natural or L.P. gas.

TO REPLACE BURNER TUBES

1. Discontinue power to the dryer.
2. Close shutoff valve in the gas supply line.
3. Disconnect the gas valve wiring.
4. Break union connection before gas valve.
5. Loosen and remove two (2) screws securing the gas valve bracket to the burner.
6. Remove gas valve/manifold assembly from the dryer.
7. Remove the screws securing the front flanges of the burner tubes to the burner rest.
8. Remove burner tubes by sliding them out.
9. Replace by reversing procedure.

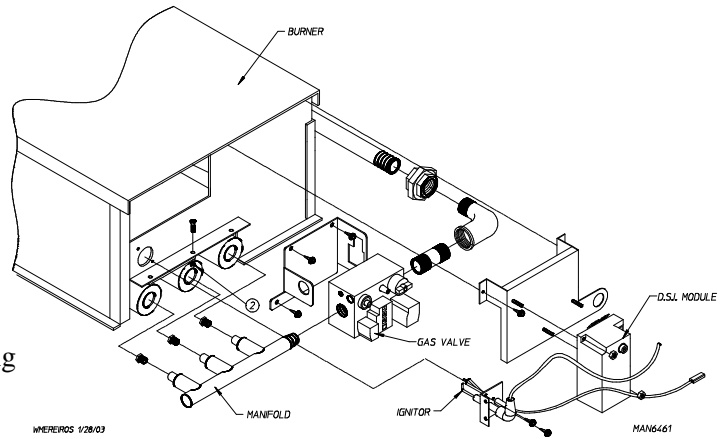

WARNING: Test ALL connections for leaks by brushing with a soapy water solution (liquid detergent works well).



WARNING: NEVER TEST FOR LEAKS WITH A FLAME!!!

TO REPLACE DIRECT SPARK IGNITION (DSI) MODULE

1. Discontinue power to the dryer.
2. Remove the wires connected to the terminal strip at the top of the module, and wires connected on the side of the module.
3. Remove the high voltage (HV) wire from the module.
4. Remove the two (2) hex nuts securing the module to the module mounting bracket.
5. Replace module by reversing process.

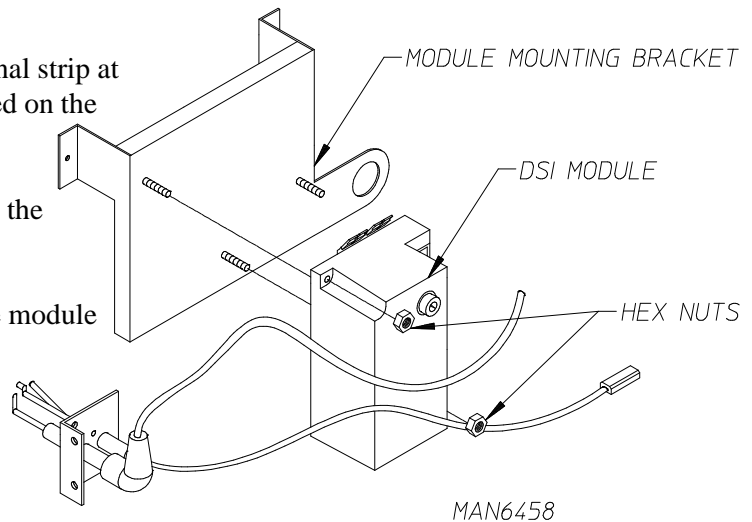

WMEDEIROS 1/28/03

C. STEAM CONTROLS

INSTALLATION

Piping **must be** installed in accordance with good commercial steam system practice. Refer to the **illustration below** for a typical pipe arrangement.

STEAMDAMPER SYSTEM

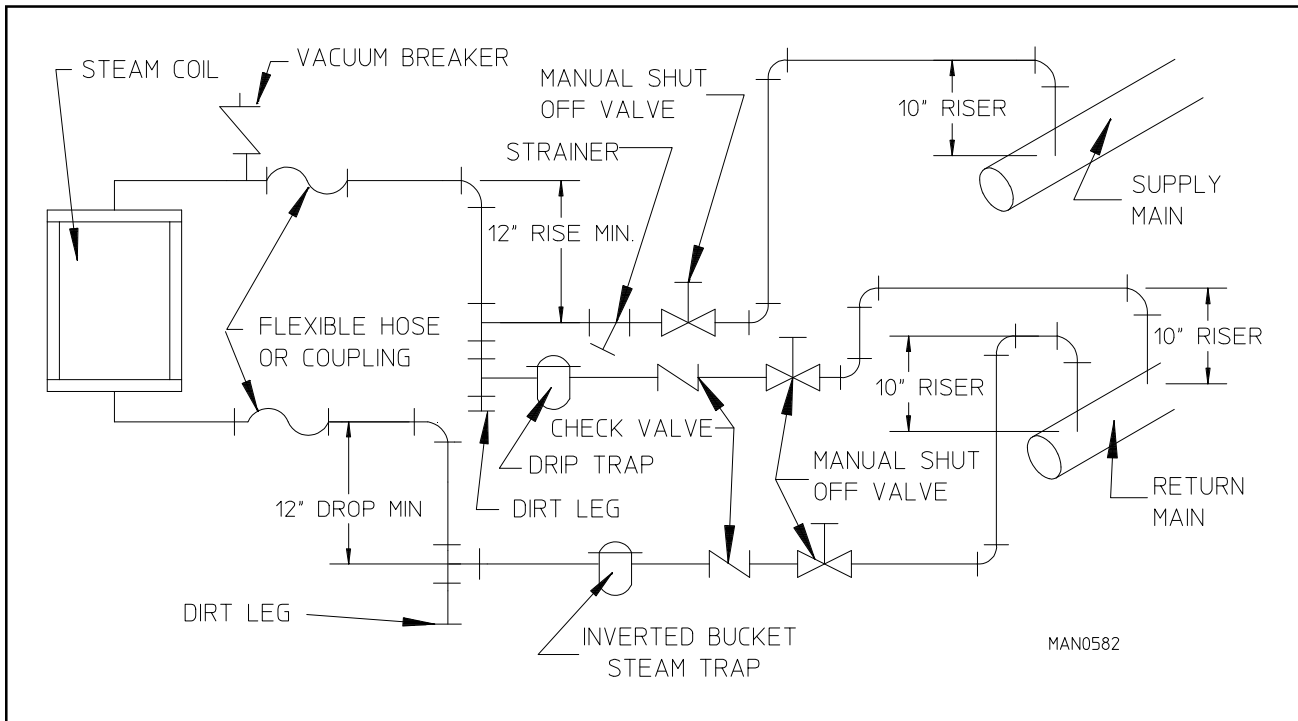

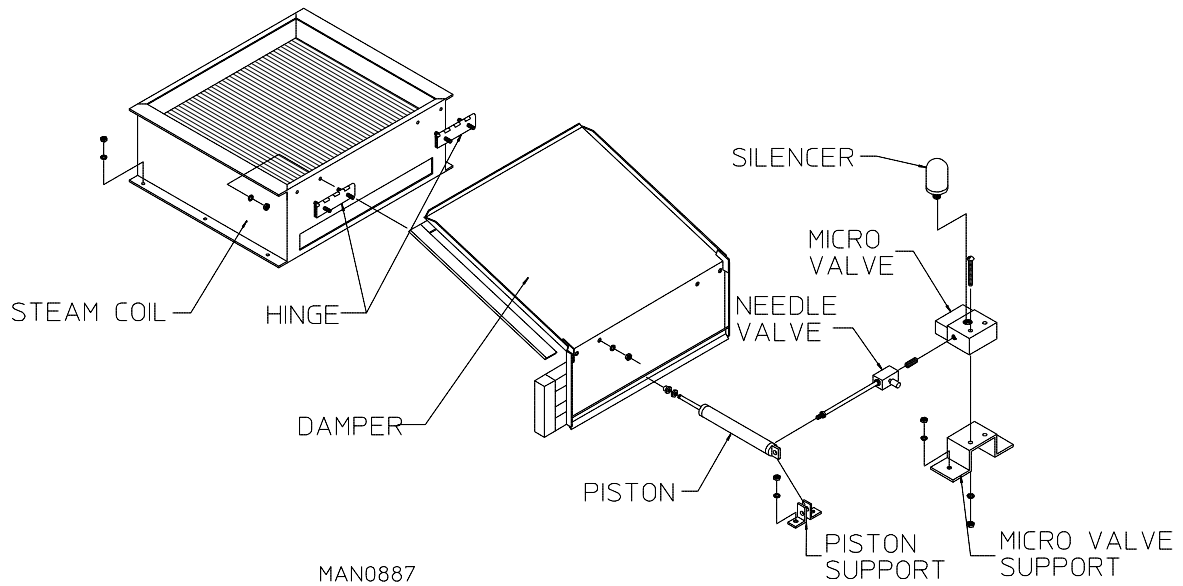

TO REPLACE STEAM COIL (DAMPER SYSTEM)

1. Discontinue power to the dryer.
2. Remove the four (4) lock washers and hex nuts securing the hinges to the steam coil.
3. Remove hinges from the steam coil housing (these will be used on the new assembly).
4. Remove six (6) washers and hex nuts securing steam coil to the dryer.
5. Remove the steam coil assembly.
6. Reverse procedure for the new steam coil assembly.

TO REPLACE PISTON

1. Discontinue power to the dryer.
2. Discontinue the air supply to the dryer.
3. Remove left and right piston supports by removing two (2) washers and hex nuts and slide pin out.
4. Remove 1/8" M.P.T. connector from the piston and remove acorn nut on the end of piston shaft (this will be used on the new piston).
5. Reverse procedure for installing the new piston.

TO REPLACE THE NEEDLE VALVE

1. Discontinue power to the dryer.
2. Discontinue the air to the dryer.
3. Remove the 1/8" brass close nipple from the needle valve.
4. Remove the 1/8" M.P.T. connector from the needle valve.
5. Remove the needle valve.
6. Reverse procedure to install the new needle valve.

TO REPLACE THE 3-WAY MICROVALVE

1. Discontinue power to the dryer.
2. Discontinue the air to the dryer.
3. Remove inlet side of air from the 3-way valve.
4. Remove the two (2) 1" machine bolts and mounting hardware holding the 3-way valve to the bracket.
5. Remove the 1/8" brass close nipple from the outlet side of the valve.
6. Remove valve.
7. Reverse procedure to install the new microvalve.

TO REPLACE STEAM COIL

1. Shut off steam supply line to the dryer and run dryer to remove any condensation.
2. Discontinue power to the dryer.
3. Break union at flexible hose just before the steam coil at both inlet and outlet.



CAUTION: Steam coil and/or piping may be hot, allow time to cool.

4. Remove remaining piping from steam coil.
5. Remove six (6) screws holding coil to steam rack and lift core out.
6. Reverse procedures for installing new core.

D. ELECTRICAL OVEN CONTROLS

TO REPLACE ELECTRICAL ELEMENTS

1. Discontinue power to the dryer.
2. Remove cover by removing screws and lifting the cover.
3. Remove the nuts and wiring holding the element in place at the rear of the oven.
4. From the front of the oven, slide out element.
5. Reverse procedure for installation of new element.

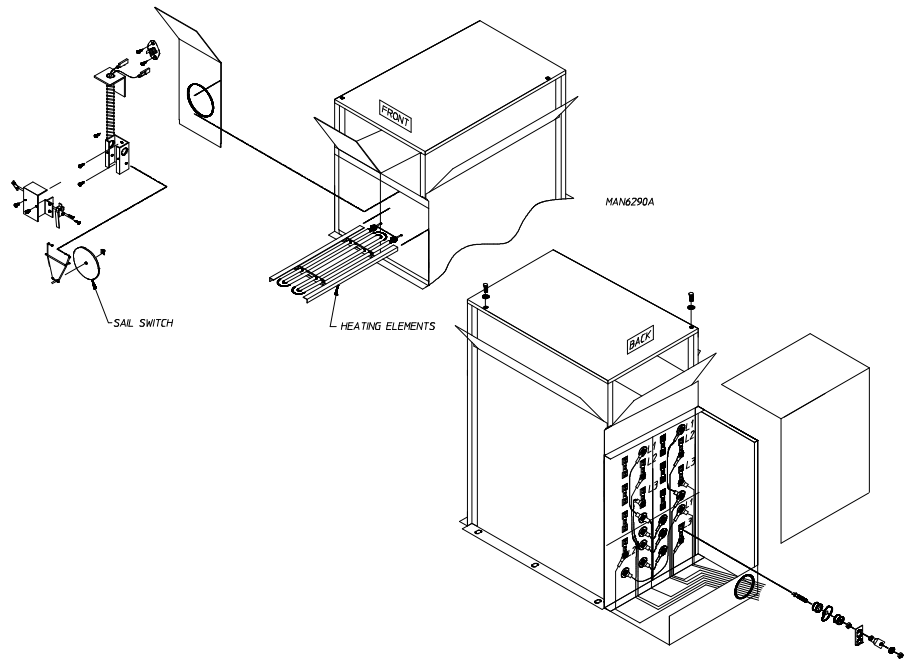

TO REPLACE OVEN CONTACTOR

1. Discontinue power to the dryer.
2. Remove cover by removing the screws and lifting the cover off.
3. Remove wiring from contactor.
4. Remove three (3) nuts and lug nuts from the studs.
5. Pull contactor off.
6. Reverse procedure for installing new contactor.

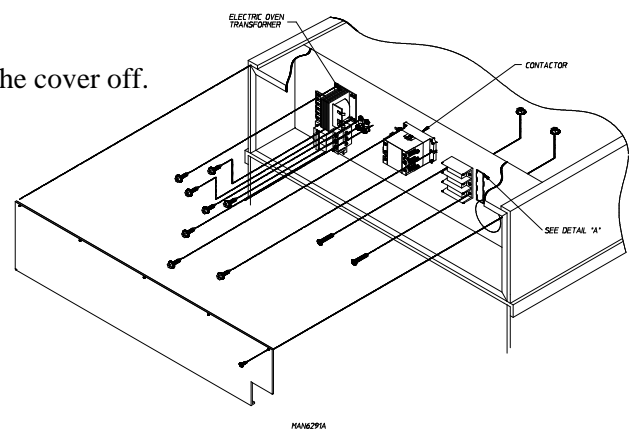

E. THERMOSTATS AND TEMPERATURE SENSOR

TO REPLACE HI-LIMIT THERMOSTAT (330° GAS, 290° ELECTRIC)

This thermostat is an important safety device serving as an added protection against failure of the air sail switch to open in the event of motor failure or reduced airflow condition.



IMPORTANT: UNDER NO CIRCUMSTANCES should heat circuit safety devices ever be disabled.

1. Discontinue power to the dryer.
2. Disconnect wires from hi-limit thermostat.
3. Remove screw, washer, and nut securing thermostat to the bracket. Remove thermostat.
4. Reverse procedure for installing new thermostat.

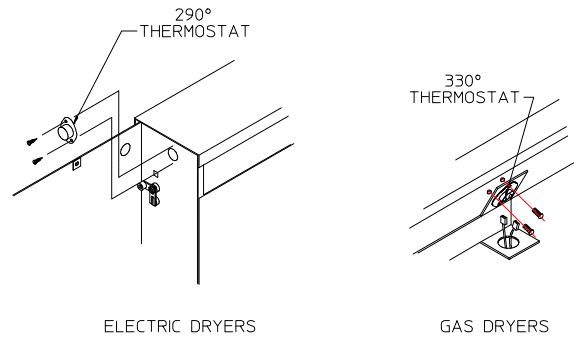

MAN0671

TO REMOVE THE TEMPERATURE SENSOR OR HIGH HEAT PROTECTOR (MICROPROCESSOR MODELS)

A. HIGH HEAT PROTECTOR

1. Discontinue power to the dryer.
2. Open and remove the lint door.
3. Locate temperature sensor bracket assembly under the basket (tumbler). Loosen the two (2) Phillips head screws. Disconnect the connector.
4. Slide bracket toward rear of the dryer and remove the bracket assembly from the dryer.
5. At this point, you have access to remove either the high heat protector or the temperature sensor.
6. To remove the high heat protection, remove the two (2) screws, washers, and nuts holding the high heat protector in place.
7. Remove the high heat protector.
8. Reverse procedure for installation of the new high heat protector.

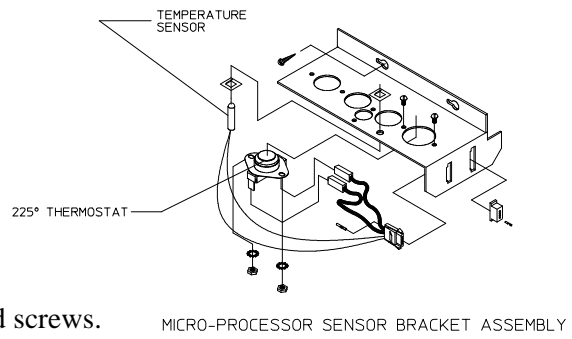

MAN1019

B. TEMPERATURE SENSOR (MICROPROCESSOR MODELS)

1. Discontinue power to the dryer.
2. Open and remove the lint door.
3. Disconnect sensor bracket harness connector.
4. Loosen the two (2) Phillips head screws securing bracket assembly to dryer and remove by sliding bracket towards the rear of the dryer.
5. Disassemble sensor probe from bracket assembly by removing the top push on fastener securing the probe to the basket (tumbler).
6. Disconnect the two (2) orange wires from the high heat temperature thermostat. Remove the 4-position connector, wires, and probe from the bracket assembly.
7. Install the new probe assembly (**ADC Part No. 880251**) by reversing procedure.

F. SAIL SWITCH ASSEMBLY (GAS AND ELECTRIC MODELS)

The sail switch is a heat circuit safety device, which controls the heat circuit only. When the dryer is operating and there is proper airflow, the sail switch damper pulls in and closes the sail switch. If an improper airflow occurs, the sail switch damper will release, and the circuit will open.



IMPORTANT: UNDER NO CIRCUMSTANCES should heat circuit safety devices ever be disabled.

TO REPLACE SAIL SWITCH

1. Discontinue power to the dryer.
2. Remove the two (2) screws, which mount the sail switch box.
3. Disconnect the two (2) wires from the switch.
4. Disassemble sail switch from mounting bracket by removing the two (2) screws securing the switch in place.
5. Reverse this procedure for installing the new sail switch. Adjust sail switch as described in the next section.

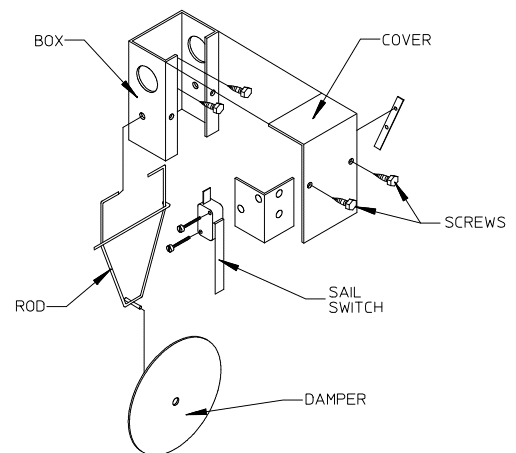

MAN0569

TO ADJUST SAIL SWITCH

1. Operate the installed dryer normally to verify that the heat system is fully operational.
2. Open the main dryer door.
3. Manually depress the door switch actuator.
4. While continuing to depress the door switch actuator, and with the door open, start the dryer.
5. If the heat system is not activated in 15-seconds, the sail switch is properly adjusted.
6. If the heat system is activated, the sail switch is improperly adjusted and **must be** readjusted by bending the actuator arm of the sail switch toward the front of the dryer. If the actuator arm is bent too far toward the front of the dryer, the dryer may not have heat when needed. After any adjustments of the sail switch, the above procedure **must be** repeated to verify proper operation.



CAUTION: DO NOT disable this switch by taping or screwing sail switch damper to burner. Personal injury or fire could result.

G. FRONT PANEL AND MAIN DOOR ASSEMBLIES

TO REPLACE MAIN DOOR SWITCH

1. Discontinue power to the dryer.
2. Open the main door.
3. Remove the two (2) Phillips head screws holding the main door switch cover in place.
4. Remove the two (2) nuts and washers securing the switch to the door hinge, and take the switch off the two (2) clinch studs on the hinge.
5. Disconnect the two (2) wires on the door switch. Connect the new door switch to those two (2) wires.
6. Reverse this procedure for installing the new door switch.

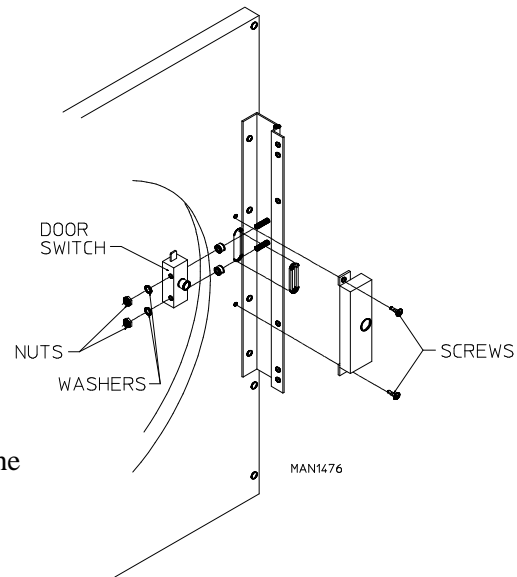

IMPORTANT: UNDER NO CIRCUMSTANCES should the door switch be disabled.

TO REPLACE MAIN DOOR ASSEMBLY

1. Remove screws holding main door to main door hinge.
2. Reverse this procedure for reinstalling the new main door assembly.

TO INSTALL NEW MAIN DOOR GLASS

1. Remove main door assembly from the dryer (follow main door removal procedure).
2. Lay main door on a flat surface with front of door face down.
3. Remove glass and clean **ALL** old sealant off main door. This area **must be** completely cleaned for correct bonding.
4. Apply narrow bead of silicone (ADC Part No. 170730 for plastic type doors and cast type doors) **ALL** around main door area where glass will rest.
5. Install glass onto door/adhesive and slightly press glass in place.



IMPORTANT: DO NOT press hard or silicone thickness between the glass and door **will be** reduced resulting in poor bonding.

6. The door assembly **should now be** put in an area where it **will not be** disturbed for at least 24 hours. Depending on the conditions, the curing time of the adhesive is 24 to 36 hours.
7. After 24 hour curing period, install main door on dryer by reversing **Step #1**.

TO REPLACE FRONT PANEL

1. Discontinue power to the dryer.
2. Follow procedure for removal of main door assembly.
3. Open control (service) door.
4. Remove the lint drawer.

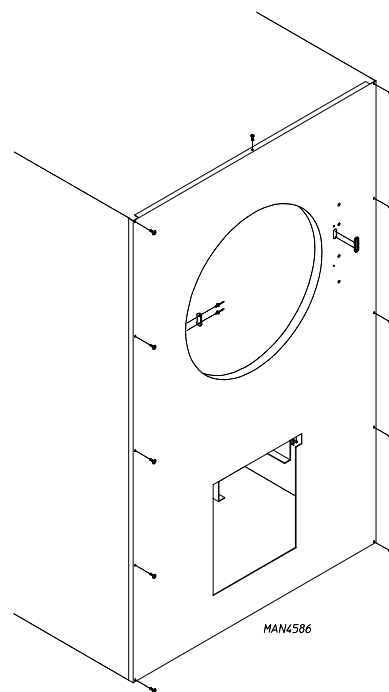

5. Remove the screws securing the front panel to the dryer.
6. Gently remove the top right hand corner of the front panel assembly from the dryer.
7. Disconnect the main door switch harness at the connector.



IMPORTANT: When removing front panel assembly, be careful not to damage main door switch wires disconnected in *Step #2*.

8. Reverse this procedure for installing the new front panel.

TO REPLACE MAIN DOOR HINGE

1. Discontinue power to the dryer.
2. Follow procedure for removal of the main door assembly.
3. Follow procedure for removal of the front panel assembly.
4. Disassemble hinge from the front panel by removing the nuts located on the back side of the front panel, which hold the hinge to the front panel.



IMPORTANT: When removing the hinge assembly from front panel, be careful you ***DO NOT*** damage the main door switch wires.

5. Remove the main door switch assembly.
6. Reassemble by reversing the removal procedure.

TO REPLACE THE NYLON CATCH

1. Open the main door.
2. Drill out the two (2) pop rivets holding the nylon catch to the front panel, using a #21 (0.1590) drill bit.
3. Using two (2) pop rivets (**ADC** Part No. 154215), install nylon catch (**ADC** Part No. 170330) to the front panel.

H. BASKET (TUMBLER) AND BEARING ASSEMBLY

(Remove back guard to access assembly)

TO REPLACE BASKET (TUMBLER) PULLEY (Non-Reversing)

1. Loosen V-belts, then rotate pulley and roll V-belts out of the grooves.
2. Loosen two (2) setscrews on the pulley and pull the pulley off the shaft.
3. Reverse procedure for installing the new basket (tumbler) pulley.



NOTE: Check belt alignment before operating the dryer.

TO REPLACE BASKET (TUMBLER) PULLEY (Reversing)

1. Loosen V-belts, then rotate pulley and roll V-belts out of the grooves.
2. Remove cap screws securing taper lock hub to pulley.
3. Insert cap screws in tapped removal holes and tighten evenly until bushing becomes loose in pulley. See figure "A."
4. Remove bushing, pulley, and key.
5. Assemble bushing and pulley as shown in figure "B." When cap screws are loosely inserted, bushing remains fully expanded to provide a sliding fit to the shaft.
6. Insert key on the shaft, then slide pulley to desired position with cap screw heads to the outside.
7. Tighten cap screws progressively. There remains a gap between the pulley hub and the flange of the bushing.



IMPORTANT: Tighten screws evenly and progressively. Never allow the pulley to be in contact with the flange of the bearing. This gap should measure from 1/8" to 1/4". Proper cap screw torque is 30 ft-lb. (40.67 Nm), if greater tightening forces are applied, excess pressure **will be** created in the hub of the mounted pulley, which may cause it to crack.

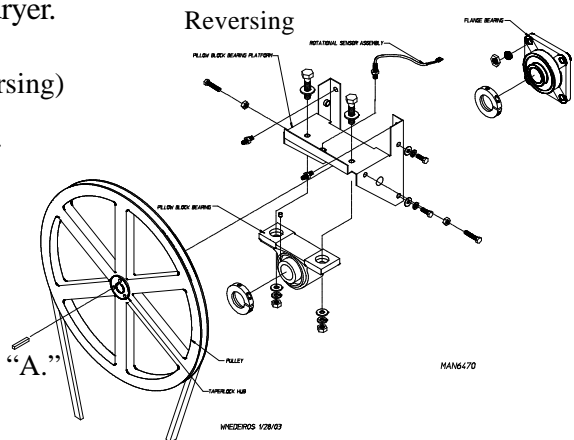
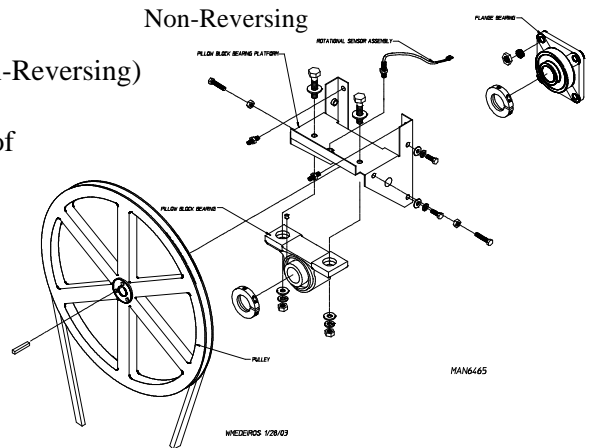

A

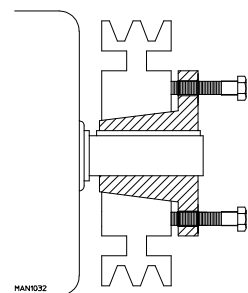

B

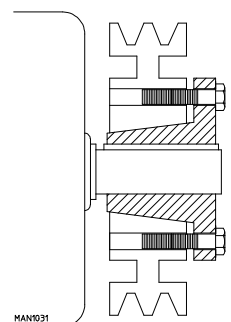

TO REPLACE THE REAR BASKET (TUMBLER) BEARING

1. Remove the basket (tumbler) pulley (follow basket [tumbler] pulley removal procedure).
2. Remove the four (4) bolts securing the bearing platform to the back of the dryer.
3. Loosen Allen screw securing bearing collar to the shaft.
4. Slide bearing collar off the basket (tumbler) support.
5. Pull bearing platform and bearing housing off of shaft.



NOTE: If any rust has developed, use an emery cloth to polish the shaft.

6. Remove bolts securing bearing housing to the bearing platform and remove the basket (tumbler) bearing.
7. Reverse procedure for installing the new basket (tumbler) bearing.



NOTE: Tighten bearing Allen screw from 80- to 90-inch pounds. Check alignment of pulleys before operating the dryer.

TO REPLACE THE FRONT BASKET (TUMBLER) BEARING

1. Remove basket (tumbler) pulley and bearing box (follow “TO REPLACE THE REAR BASKET [TUMBLER] BEARING” *Steps #1 through 4*).
2. Loosen Allen screw on rear basket (tumbler) bearing collar.
3. Slide collar off of the shaft.



NOTE: An alternative method would be to place a block of wood on the end of the basket (tumbler) shaft and strike it with a heavy hammer. To prevent damage to the shaft, the wheel puller method is preferred.

4. Remove the four (4) nuts securing the bearing to the dryer back and remove the bearing.
5. Reverse procedure for installing the new basket (tumbler) bearing.



NOTE: Tighten bearing Allen screw from 80- to 90-inch pounds. Check tension of belts and alignment of basket (tumbler) before operating the dryer.

6. Replace the back guard.

I. IDLER AND BEARING ASSEMBLY

(Remove back guard to access assembly)

TO REPLACE IDLER PULLEY

1. Remove the back guard.
2. Loosen V-belts, then rotate pulley and roll V-belts out of the grooves.
3. Loosen the two (2) setscrews on the pulley and pull off the shaft.
4. Reverse procedure for installing the new idler pulley.

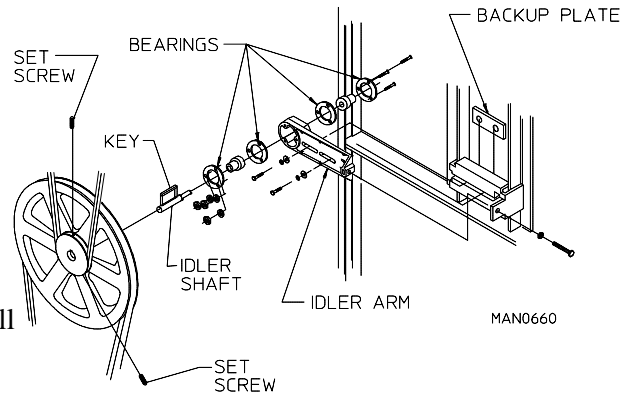

NOTE: Check tension and alignment of belts before operating the dryer.

TO REPLACE IDLER BEARING

1. Remove the idler pulley (follow “TO REPLACE IDLER PULLEY”).
2. Remove the idler arm.
 - a. Remove two (2) bolts securing idler arm to the idler backup plate.
 - b. Remove idler arm assembly.
 - c. Loosen setscrews on both the front and rear bearing and remove the idler shaft.
 - d. Remove three (3) bolts securing the bearing to the idler arm and remove bearings.
3. Reverse procedure for installing the new idler bearings.



NOTE: Check tension and alignment of belts before operating the dryer.

J. DRIVE PULLEY

(Remove back guard to access assembly)

1. Remove the back guard.
2. Loosen V-belts then rotate pulley and roll V-belts out of the grooves.
3. Loosen setscrews and pull motor pulley out.



NOTE: If rust has developed on the shaft, use an emery cloth to polish the shaft.

4. Reverse procedure for installing the new drive pulley.



NOTE: Check tension and alignment of belts before operating the dryer.

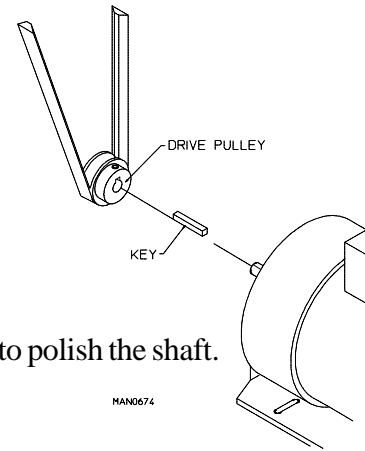

K. BASKET (TUMBLER)

BASKET (TUMBLER) ALIGNMENT (VERTICAL)

1. Discontinue power to the dryer.
2. Remove the back guard.
3. Loosen the four (4) hex head bolts on the sides of the bearing box (two [2] on each side).
4. Back off jam nuts on the two (2) Allen head adjustment screws at the top of the bearing box.
5. Turn the screws clockwise (CW) evenly to raise the basket (tumbler) or counterclockwise (CCW) evenly to lower the basket (tumbler).



NOTE: V-belt tension may need to be loosened.

6. Rotate the basket (tumbler) from the front and check alignment with the main door opening.
7. Leave a larger gap from the inside ring on the top of the front panel opening to the basket (tumbler), and a smaller gap on the bottom to compensate for the weight of the clothes being dried.

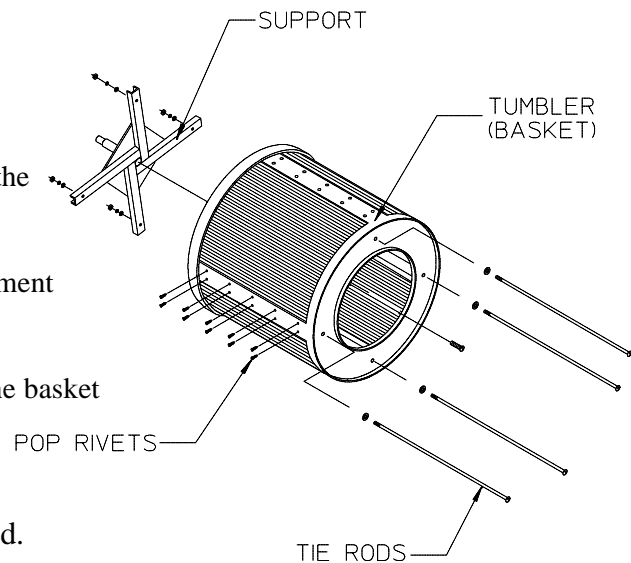

MAN0560

8. Tighten the four (4) hex head bolts on the sides of the bearing box, and the two (2) Allen head adjustment screws.
9. Replace the back guard.
10. Reconnect power to the dryer.

BASKET (TUMBLER) ALIGNMENT (LATERAL)

1. Discontinue power to the dryer.
2. Remove the back guard.
3. Loosen the two (2) hex head bolts, (one [1] turn is enough), that holds the pillow block bearing to the bearing box.
4. Back off the two (2) jam nuts on the side adjustment bolts. Now, rotate the basket (tumbler) from the front of the dryer, checking the space between the basket (tumbler) and the front panel. This **should be** equal on the left hand and right hand side.
5. Lateral adjustment (viewing from the rear).
 - a. Loosening (by turning counterclockwise [CCW]) the left hand adjustment bolt and tightening (by turning clockwise [CW]) the right hand adjustment bolt will shift the basket (tumbler) to the right.
 - b. Loosening (by turning counterclockwise [CCW]) the right hand adjustment bolt and tightening (by turning clockwise [CW]) the left hand adjustment bolt will shift the basket (tumbler) to the left.
6. Tighten and secure both adjustment bolts and jam nuts.
7. Tighten the bearing box bolts.
8. Replace the back guard and reestablish power to the dryer.

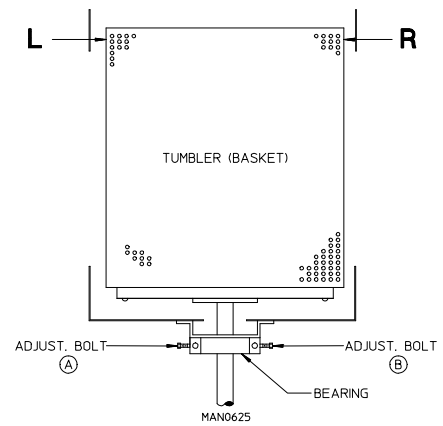

REAR OF DRYER

TO REPLACE THE BASKET (TUMBLER) AND/OR BASKET (TUMBLER) SUPPORT

1. Discontinue power to the dryer.
2. Remove the basket (tumbler) pulley.
3. Remove the front panel assembly.
 - a. Open the control (service) door.
 - b. Open the lint door.
 - c. Remove the screws securing the front panel to the dryer.
 - d. Gently remove the top right hand corner of the front panel assembly from the dryer.
 - e. Disconnect the main door switch harness at connector.



IMPORTANT: When removing the front panel assembly, be careful not to damage the door switch wires.

4. Loosen setscrews on rear basket (tumbler) bearings.
5. Using a wheel puller, gently push the basket (tumbler) shaft towards the front through the front basket (tumbler) bearings.



NOTE: An alternate method would be to place a block of wood on the end of the basket (tumbler) shaft and strike it with a heavy hammer. To prevent damage to the shaft, the wheel puller method is preferred.

6. Remove the basket (tumbler) and support through the front of the dryer.
 - a. Remove the bolt in the center of the basket (tumbler) back wall.
 - b. Loosen and remove the nuts and washers from the basket (tumbler) tie rods. Remove the rods.
 - c. Replace either basket (tumbler) or basket (tumbler) support by reversing the procedure.
7. Reassemble components into dryer by reversing ***Steps #1 through 4.***
8. Check basket (tumbler) lateral and vertical alignment. Also, check belt tension and alignment.
9. Replace the back guard and reestablish power to the dryer.

L. V-BELTS (REFER TO ILLUSTRATION IN SECTIONS I, J, AND K)

V-belts should have proper tension. If too loose, they will slip, if too tight excessive wear on the bearing will result. If the pulleys are not properly aligned, excessive belt wear will result. Proper belt tension will allow 1/2” displacement under normal thumb pressure at mid span of the belt.

V-BELT TENSION ADJUSTMENT – BASKET (TUMBLER) TO IDLER

1. Loosen two (2) bolts connecting idler arm to backup plate.
2. Back off jam nut on the adjustment bolt.
3. Tighten belts by turning adjustment bolt clockwise (CW).
(Turn counterclockwise [CCW] to loosen belts)
4. Tighten both bolts connecting idler arm to backup plate.
5. Check vertical plane of idler pulley for parallel alignment with basket (tumbler) pulley.
6. If realignment is required, loosen basket (tumbler) pulley and move basket (tumbler) pulley to proper position.
7. Retighten jam nut.

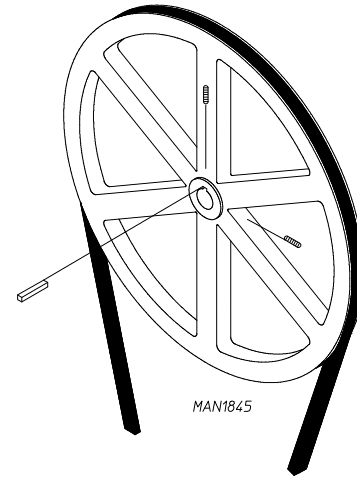

V-BELT TENSION ALIGNMENT – MOTOR TO IDLER

1. Loosen two (2) bolts connecting idler arm to backup plate.
2. Back off on jam nut(s) on the adjusting bolt.
3. Loosen/tighten adjustment bolt to decrease/increase belt tension.
4. Tighten adjustment bolt jam nut(s).
5. Tighten the two (2) bolts loosened in *Step #1*.

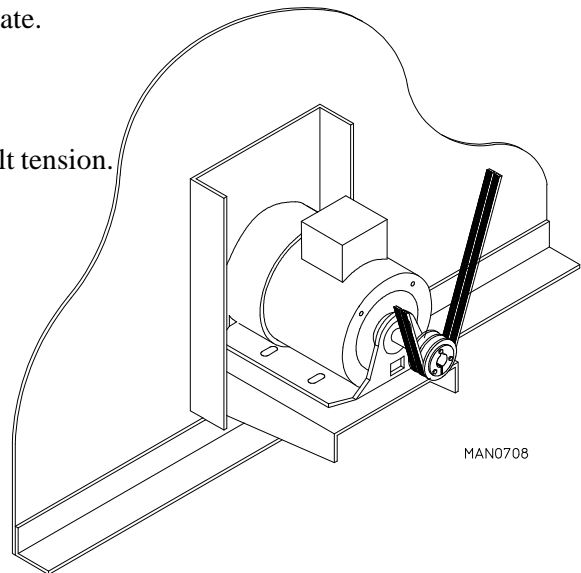

TO REPLACE V-BELTS

1. Loosen tension on V-belts, so that they can easily be rolled off pulleys.
2. Replace V-belts.
3. Retighten V-belts and adjust tension and alignment per previous instructions.

M. MOTOR

TO REPLACE MOTOR (Non-Reversing)

1. Discontinue power to the dryer.
2. Remove the drive belt.
3. Disconnect wiring harness from the motor.
4. Remove nuts and washers holding the motor mount to the rear of the dryer and pull motor mount away.
5. Remove the two (2) left hand nuts on the motor shaft securing the impellor. Work the impellor free from the motor shaft by means of a puller, to prevent damage to the motor shaft.
6. Remove the bolts holding the motor to the motor mount and replace it with a new motor.
7. Remove pulley from the old motor and install on the new motor.
8. Align motor with impellor face in plane with the motor mount at no less than 3/16" clearance.
9. Replace motor mount to the dryer.

N. IMPELLOR



NOTE: Follow *Steps #1 through 5 and 8* in “Section V, Part M.”

O. LINT DRAWER SCREEN

TO REPLACE LINT SCREEN

1. Gently slide the lint drawer outward.
2. Remove the lint bag and inspect for rips or tears. Replace with new lint bag, if damaged.
3. Reverse procedure for installing the new lint bag.
4. Close the lint drawer.

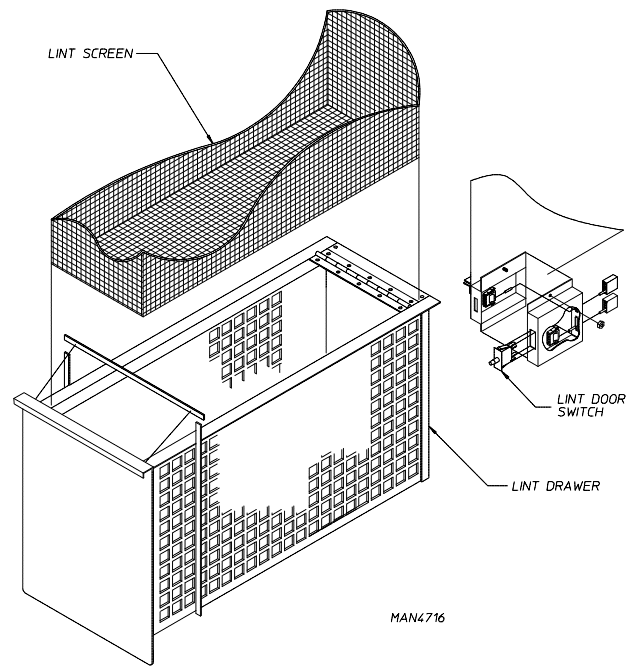

SECTION VI

TROUBLESHOOTING

The information provided will help isolate the most probable components associated with the difficulty described. The experienced technician realizes, however, that a loose connection or broken or shorted wire may be at fault where electrical components are concerned...not necessarily the suspect component itself.

Electrical parts **should always be** checked for failure before being returned to the factory.

The information provided **should not be** construed as a device for use by an untrained person in making repairs. Only properly licensed technicians should service the equipment.

Observe **ALL** safety precautions displayed on the equipment or specified in this manual while making repairs.

PHASE 7 OPL SYSTEM DIAGNOSTICS



IMPORTANT: YOU MUST DISCONNECT AND LOCKOUT THE ELECTRIC SUPPLY AND THE GAS SUPPLY OR THE STEAM SUPPLY BEFORE ANY COVERS OR GUARDS ARE REMOVED FROM THE MACHINE TO ALLOW ACCESS FOR CLEANING, ADJUSTING, INSTALLATION, OR TESTING OF ANY EQUIPMENT PER OSHA (Occupational Safety and Health Administration) STANDARDS.

ALL major circuits, including door, microprocessor temperature sensor, heat and motor circuits are monitored. The Phase 7 OPL microprocessor controller (computer) will inform the user, via the light emitting diode (L.E.D.) display of certain failure messages, along with L.E.D. indicators on the Input/Output (I/O) board on the back panel of the front right control door.

A. DIAGNOSTIC (L.E.D. DISPLAY) FAULT MESSAGES

MAIN DOOR OPENED – A main door is open, when it **should be** closed.

EXHAUST HIGH TEMP FAULT – Indicates the temperature in the basket (tumbler) is above 220° F (104° C).

LINT ACCESS OPEN – Indicates the lint drawer is open and needs to be closed.

EXHAUST HIGH LIMIT FAULT – Indicates the temperature disk in the exhaust has opened.

SAIL SWITCH CLOSED FAULT – Sail switch is closed and **should be** opened.

SAIL SWITCH OPEN FAULT – Sail switch is open and **should be** closed.

BURNER HIGH LIMIT FAULT – Indicates the temperature disk in the burner has opened.

BURNER IGNITION CONTROL FAULT – No signal to gas valve from Direct Spark Ignition (DSI) module during trial for ignition time.

IGNITION FAULT – Gas valve did not remain open after trial for ignition. Indicates that no flame was detected.

FLAME FAULT – Indicates flame was detected during trial for ignition, but failed sometime after. This condition must reoccur for five (5) retries before fault occurs.

ROTATION FAULT – Indicates the basket (tumbler) is not rotating.

OPEN EXHAUST TEMPERATURE PROBE – Indicates the exhaust temperature probe is open or shorted.

OPEN SENSOR ACTIVATED FIRE EXTINGUISHING (S.A.F.E.) SYSTEM PROBE FAULT – Indicates the temperature probe for the S.A.F.E. system is open or shorted.

LOW VOLTAGE FAULT – Indicates power has dropped below the operating values and will shutdown.

BURNER PURGE FAULT – The gas valve signal is present during the prepurge time.

MODEL ERROR, ENTER CORRECT MODEL – The wrong model was selected for the dryer.

EE PROM FAULT ### – Error in memory location. The ### indicates the location of the fault.

B. INPUT/OUTPUT (I/O) BOARD LIGHT EMITTING DIODE (L.E.D.) INDICATORS

1. INPUTS

1. ESTOP – (RED L.E.D.) This L.E.D. will indicate the status of the E-STOP. If the E-STOP has been pressed, then the L.E.D. is on.
2. GAS_V – (RED L.E.D.) This L.E.D. will indicate the status of the gas valve. If the gas valve is open (ON), then the L.E.D. is on.
3. BRHL – (RED L.E.D.) This L.E.D. will indicate the status of the burner high limit disk. If the disk is closed (temperature below 330° F [166° C]), then the L.E.D. is ON.
4. SAIL – (RED L.E.D.) This L.E.D. will indicate the status of the sail switch. If the switch is closed, then the L.E.D. is ON.
5. EXHL – (RED L.E.D.) This L.E.D. will indicate the status of the exhaust high limit disk. If the disk is closed (temperature below 225° F [107° C]), then the L.E.D. is ON.
6. MAIN – (RED L.E.D.) This L.E.D. will indicate the status of the main door. If the door is closed, then the L.E.D. is ON.
7. LINT – (RED L.E.D.) This L.E.D. will indicate the status of the lint drawer. If the drawer is closed, then the L.E.D. is ON.
8. FUSE – (RED L.E.D.) This L.E.D. will indicate the status of the control voltage. If the POWER ON button is pressed (green button light is on), then the L.E.D. is ON.

2. OUTPUTS

9. AUX – (GREEN L.E.D.) This is for a spare output to be programmed.
10. STEAM – (GREEN L.E.D.) This light emitting diode (L.E.D.) will indicate the status of the steam injection output. If the request to turn on the steam injection is made, then the L.E.D. is ON.
11. _HEAT – (GREEN L.E.D.) This L.E.D. will indicate the status of the heat output. If the request to turn on the heater is made, then the L.E.D. is ON.
12. AIR – (GREEN L.E.D.) This L.E.D. will indicate the status of the air jet output. If the request to turn on the air jet is made, then the L.E.D. is ON.
13. REV – (GREEN L.E.D.) This L.E.D. will indicate the status of the basket (tumbler) reverse direction output. If the request to tumble the drum in the reverse direction is made, then the L.E.D. is ON.
14. FWD – (GREEN L.E.D.) This L.E.D. will indicate the status of the basket (tumbler) forward direction output. If the request to tumble the drum in the forward direction is made, then the L.E.D. is ON.
15. FAN – (GREEN L.E.D.) This L.E.D. will indicate the status of the fan output. If the request to turn on the fan (blower) is made, then the L.E.D. is ON.

A. The display reads “Exhaust High Limit Fault.” (Refer to page 50)

The temperature in the basket (tumbler) is above 220° F (104° C) or follow *Steps #1 through 4*.

1. Check for voltage (24 VAC) at the computer on the J5 connector from pin 1 to ground. If no voltage is present, either you have a poor connection at the J5 connector or the computer board is faulty. If voltage (24 VAC) is present, proceed to *Step #2*.
2. Check for voltage (24 VAC) at the J12 connector pin 3 to ground. If no voltage is present, there may be a poor connection at the J12 connector or a break in the wire going back to the J5 connector. If 24 VAC is present, proceed to *Step #3*.
3. Check for voltage on the J12 connector pin 4. If no voltage is present (24 VAC), check basket (tumbler) thermostat reset. If popped, push in to reset. If thermostat does not reset, then replace with new thermostat. If thermostat has not tripped, then check for poor connection in wire. If voltage is present, proceed to *Step #4*.
4. Check for voltage at the J5 connector pin 2 to ground. If no voltage is present, check for a loose wire between the J5 connector and the J12 connector.

B. The display reads “Burner High Limit Fault.” (Refer to page 51)

1. Indicates the basket (tumbler) Hi-Limit has tripped.
2. Check for a block or restriction in the exhaust.
3. Make sure the exhaust is properly sized.
4. Make sure location has adequate make-up air.
5. Check for voltage (24 VAC) at the computer board J4 connector pin 3 red wire 31 to ground. If no voltage (24 VAC), check for a loose connection or change the computer board. If voltage is present, proceed to *Step #6*.
6. Check for voltage at the J11 connector pin 2 to ground. If no voltage (24 VAC), check for a loose connection in the wire, or check the oven Hi-Limit reset. If it has tripped, push in to reset.

C. The display reads “Bad Exhaust Temp Probe.” (Refer to page 54)

1. Check for a loose connection at the computer J3 connector to temperature sensor probe. If connections are fine, next change the temperature sensor probe. If the display still reads “Bad Exhaust Temp Probe,” change the computer board.

D. The display reads “Sail Switch Open Fault.” (Refer to page 51)

1. The sail switch has opened while dryer is in the heating mode.
2. Check for block or restriction in the exhaust.
3. Make sure exhaust is sized properly.
4. Clean the lint screen.

E. The display reads “Sail Switch Closed Fault.” (Refer to page 51)

1. Prior to start up, the sail switch is in the closed position.
2. Check the sail switch and readjust accordingly.
3. Replace sail switch, if necessary.

F. The display reads “Burner Ignition Control Fault.” (Refer to page 51)

1. Check for 24 VAC at the DSI module across MV and GND. If no voltage, replace the DSI module. If voltage is present, check for 24 VAC at the gas valve on terminals 1 and 2. If no voltage, check for a loose connection on the wires going back to the DSI module. If voltage is present, proceed to *Step #2*.
2. Make sure the gas valve shutoff is in the on position.
3. Make sure proper gas pressure is supplied to the gas valve (6.0 - 12.0 inches [14.92 - 29.9 mb] water column [W.C.] for natural gas and 10.5 inches [26.1 mb] water column for liquid propane [L.P.] gas).

G. Basket (tumbler) will not rotate (non-reversing models), display reads “Rotation Fault.” (Refer to page 52)

1. Possible causes:
 - a. Belt is broke, loose, or slipping.
 - b. Lint accumulation on the rotational sensor.
 - c. Rotational sensor magnet is missing or broke. Reset power, then, restart the dryer.
 - d. Check for 24 VAC at the computer board J8 connector pin 7 blue/silver wire to GND. If no voltage is present, check for a loose connection, if connection is good, replace computer. If voltage is present, proceed to next step.
 - e. Check for 24 VAC on the motor contactor A1 to A2. If no voltage, check for a loose connection in the wire. If voltage is present, proceed to next step.
 - f. Check for 24 VAC on the motor contactor across T1 and T2. If no voltage, replace motor contactor. If voltage is present, proceed to next step.
 - g. Use a nonconductive device (i.e., wooden pencil) to push in on the motor contactor. If motor does not come on, the problem is a faulty motor.

H. Drive motor reverses, but does not go forward, blower motor runs. The display reads “Rotation Fault.”* (Refer to **page 56**)

1. Possible causes:
 - a. Belt is broke, loose, or slipping.
 - b. Lint accumulation on the rotational sensor.
 - c. Rotational sensor magnet is missing or broke. Reset power, then, restart the dryer.
 - d. Check for 24 VAC at the computer board J8 connector pin 8 brown wire to GND. If no voltage is present, check for a loose connection, if connection is good, replace computer. If voltage is present, proceed to next step.
 - e. Check for 24 VAC on the drive motor contactor forward side A1 to A2. If no voltage, check for a loose connection in the wire going back to the blower contactor A2. If voltage is present, proceed to next step.
 - f. Check for proper voltage on the T1, T2, and T3 side of the drive contactor. If no voltage, replace drive contactor. If voltage is present, proceed to next step.
 - g. Use a nonconductive device (i.e., wooden pencil) to push in on the motor contactor. If motor does not come on, the problem is a faulty motor.

I. Drive motor operates in forward mode, but does not reverse, blower motor runs. The display reads “Rotation Fault.”* (Refer to **page 56**)

1. Possible causes:
 - a. Belt is broke, loose, or slipping.
 - b. Lint accumulation on the rotational sensor.
 - c. Rotational sensor magnet is missing or broke. Reset power, then, restart the dryer.
 - d. Check for 24 VAC at the computer board J8 connector pin 9 gray wire to GND. If no voltage is present, check for a loose connection, if connection is good, replace computer. If voltage is present, proceed to next step.
 - e. Check for 24 VAC on the drive motor contactor reverse side A1 to A2. If no voltage, check for a loose connection in the wire going back to the blower contactor A2. If voltage is present, proceed to next step.
 - f. Check for proper voltage on the T1, T2, and T3 side of the drive contactor. If no voltage, replace drive contactor. If voltage is present, proceed to next step.
 - g. Use a nonconductive device (i.e., wooden pencil) to push in on the motor contactor. If motor does not come on, the problem is a faulty motor.

J. No display condition or display reads “Low Voltage Fault.”* (Refer to page 53)

1. Check for line voltage (120, 208, 240, etc.) in the rear of the dryer at the distribution block. If no voltage is present, the problem may be a faulty or tripped breaker. If voltage is present, check for line voltage (120, 208, 240, etc.) at FIA (refer to illustration on page 53) to neutral. If no voltage is present, check for blown fuse or loose connection.
2. If voltage is present, check for voltage (24 VAC) on the motor contactor T3. If no voltage is present, check for a loose connection. If connection is fine, replace the transformer. If voltage is present, check for 24 VAC at the J17 connector on the pink wire pin 3 to ground. If no voltage is present, check for a loose connection.
3. If voltage is present, check for 24 VAC on the microprocessor J8 connector pin 1 pink wire to ground. If no voltage is present, check for a loose connection. If voltage is present, check the 1/2-Amp fuse on the computer board marked “F1.” If fuse is not blown, then the problem is a faulty microprocessor.

K. The display reads “Open Sensor Activated Fire Extinguishing (S.A.F.E.) System Probe Fault.” (Refer to page 54)

1. Check for a loose connection or shorted wire at the microprocessor at the J3 connector pin 7 red wire to the J10 connector pin 1.
2. Check for a loose connection or short in the wire at the microprocessor J3 connector pin 8 black wire.
3. Check for a loose connection at the 2-pin connector P10.
4. S.A.F.E. system probe may be shorted and needs to be replaced.

L. The display reads “Cycle Paused, Main Door Open.” (Refer to page 55)

1. Make sure main door is closed.
2. Make sure main door has good contact with the main door switch.
3. Check for a loose connection at the microprocessor J8 connector pins 5 and 6 orange/silver wires.
4. Check for a loose connection at the connector pins 1 and 3.
5. Check for a loose connection at the main door switch.
6. When the door switch button is in the closed position, check for continuity. If no continuity, replace the door switch.

M. The display reads “Cycle Paused, Lint Access Open.” (Refer to page 55)

1. Make sure lint drawer is closed.
2. Check for a loose connection at the microprocessor J8 connector pins 3 and 4 orange/silver wires.
3. Check for a loose connection at the J18 connector pins 1 and 4 orange/silver wires.
4. When the lint drawer switch is pressed in, check for continuity. If no continuity, replace the lint drawer switch.

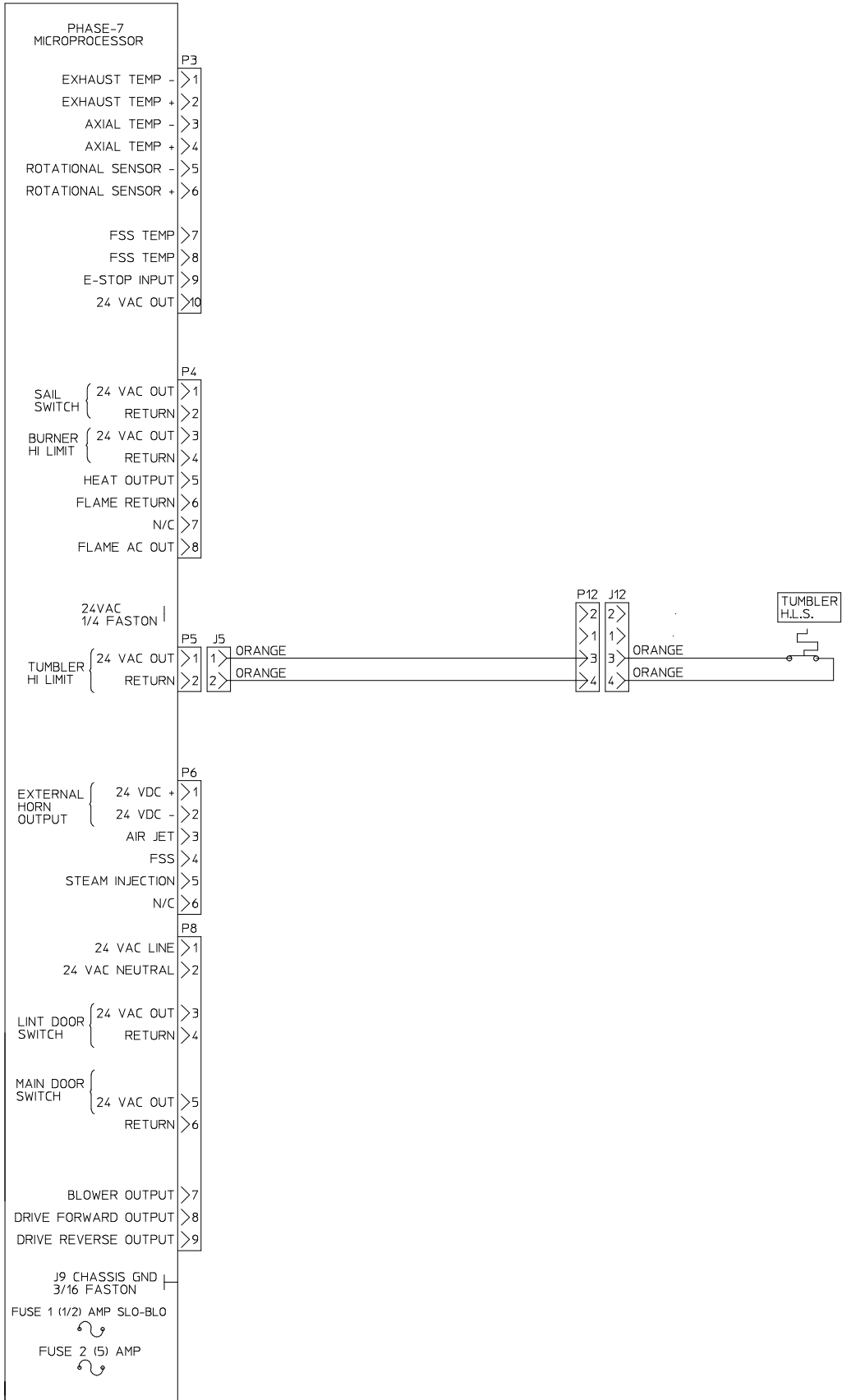

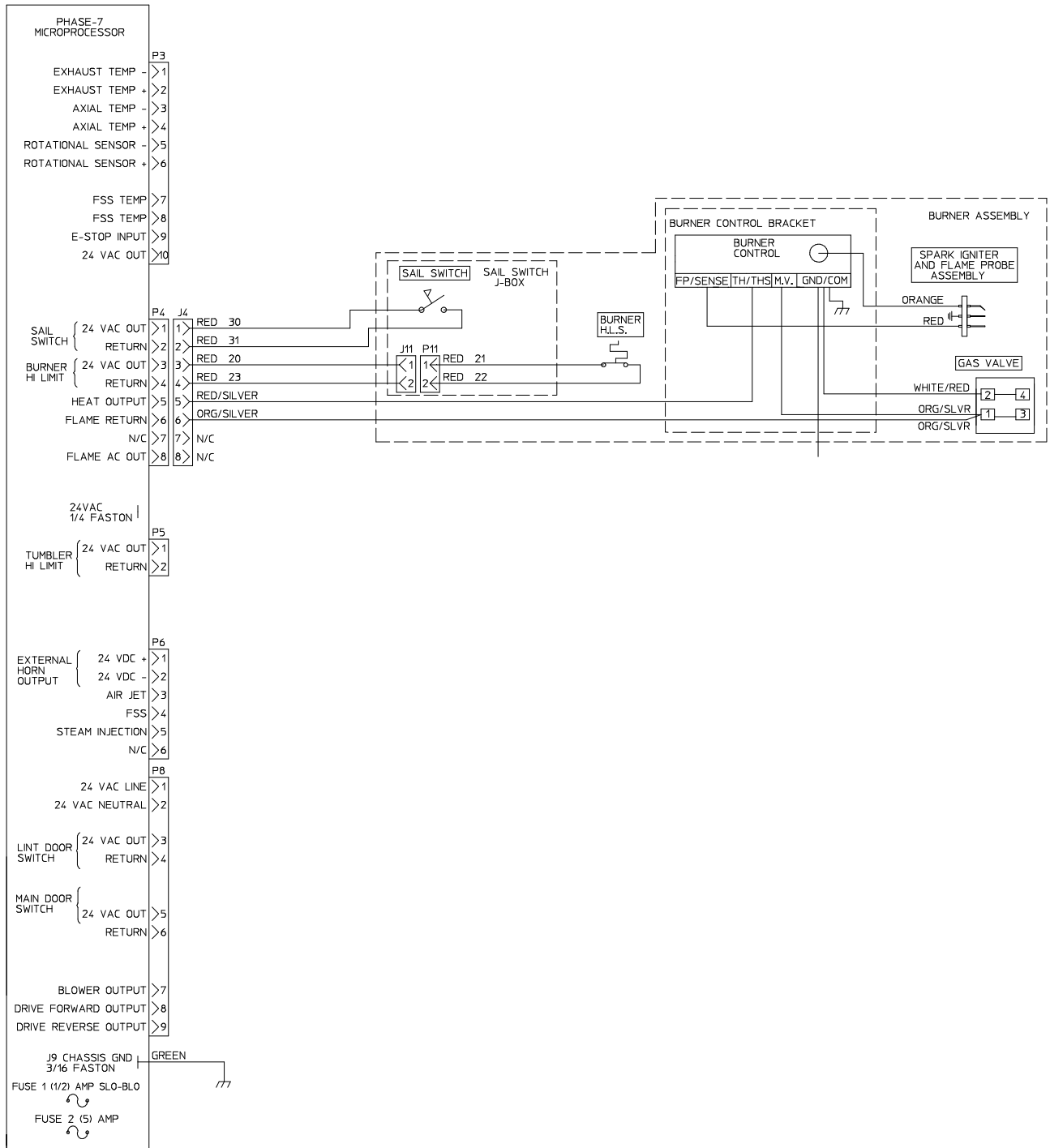

AS 1/24/03

MAN6455

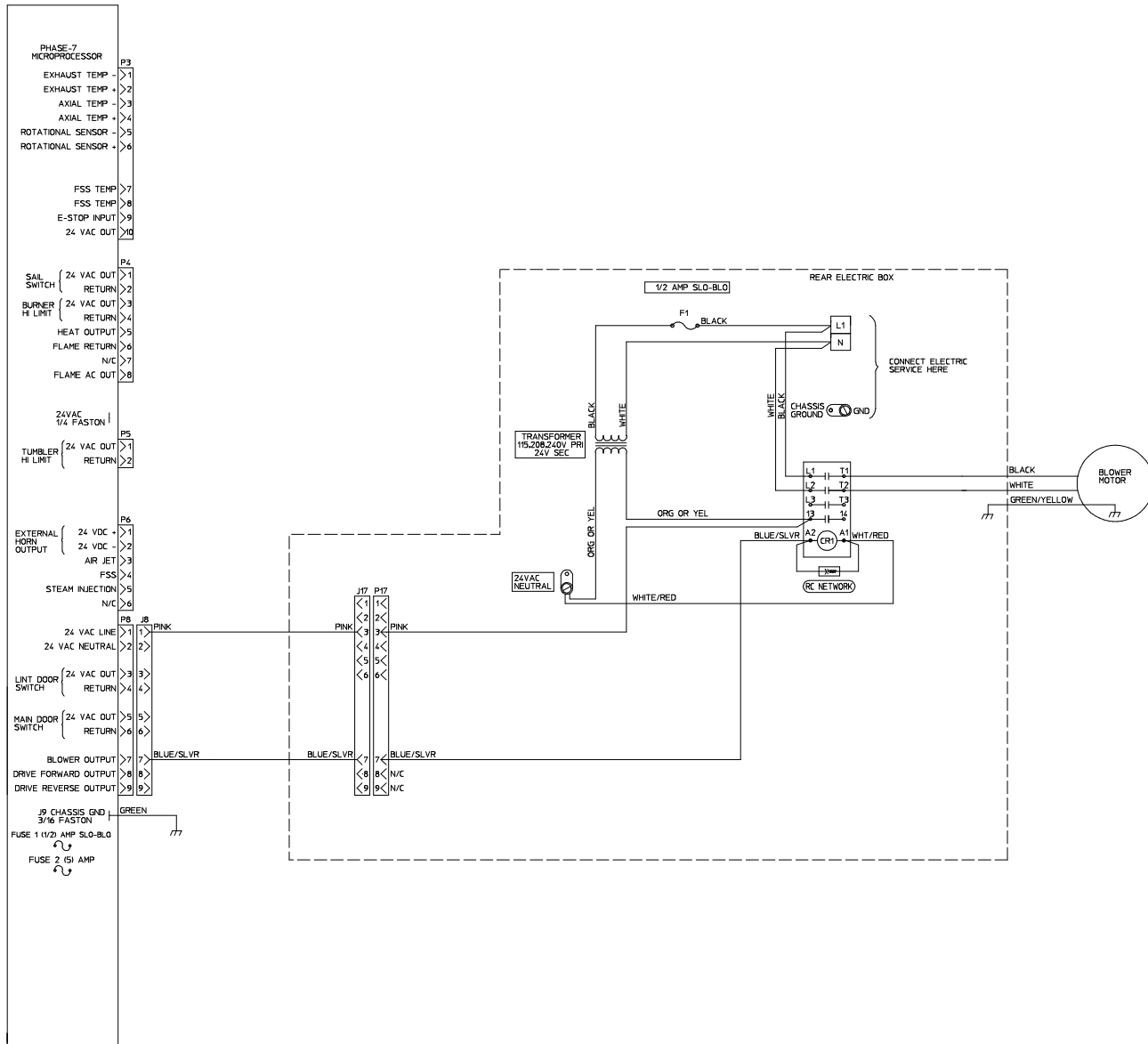

AS 1/30/03

MAN6476

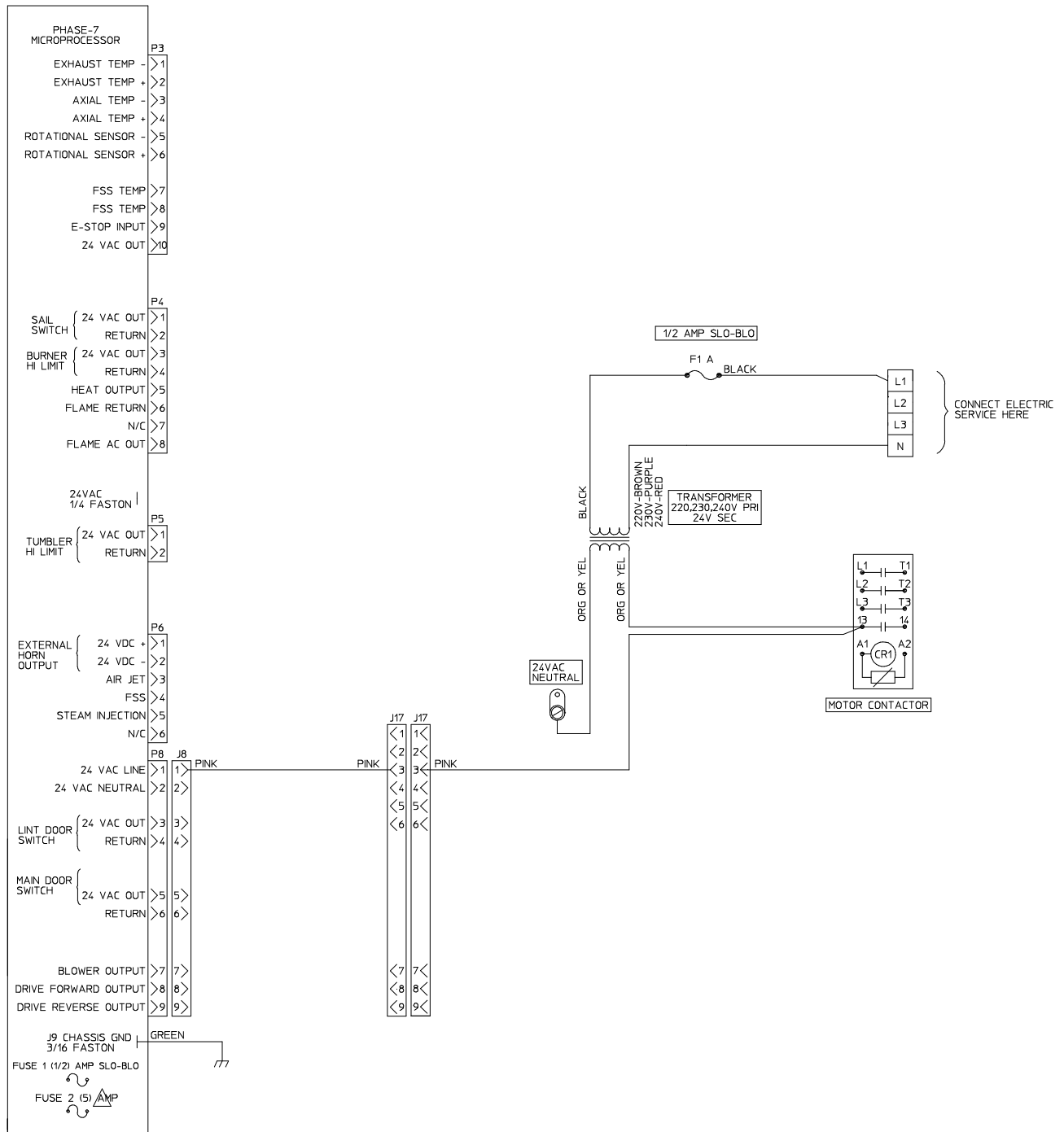

AS 2/4/03

MAN6508

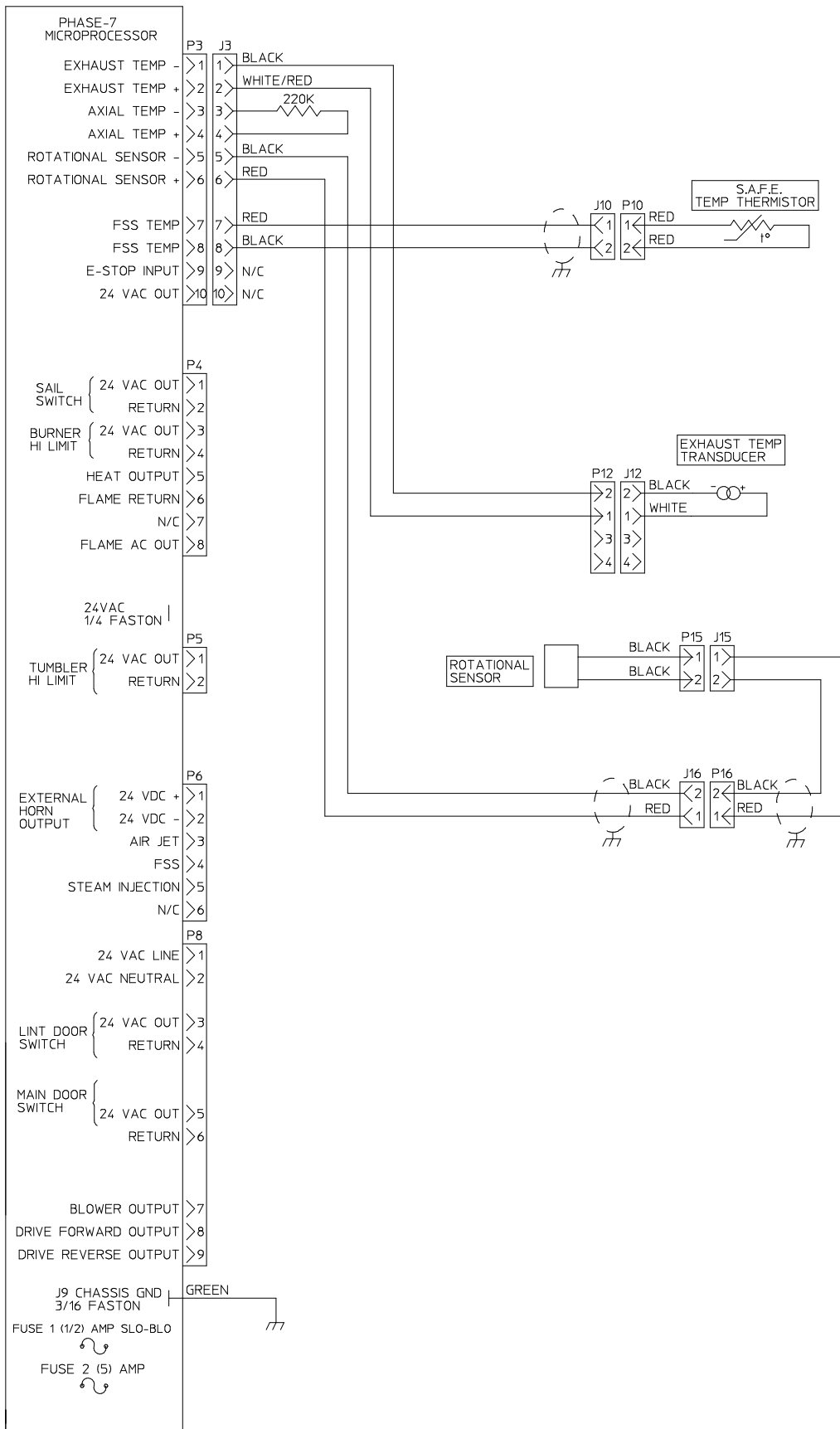

WM 2/6/03

MAN6527

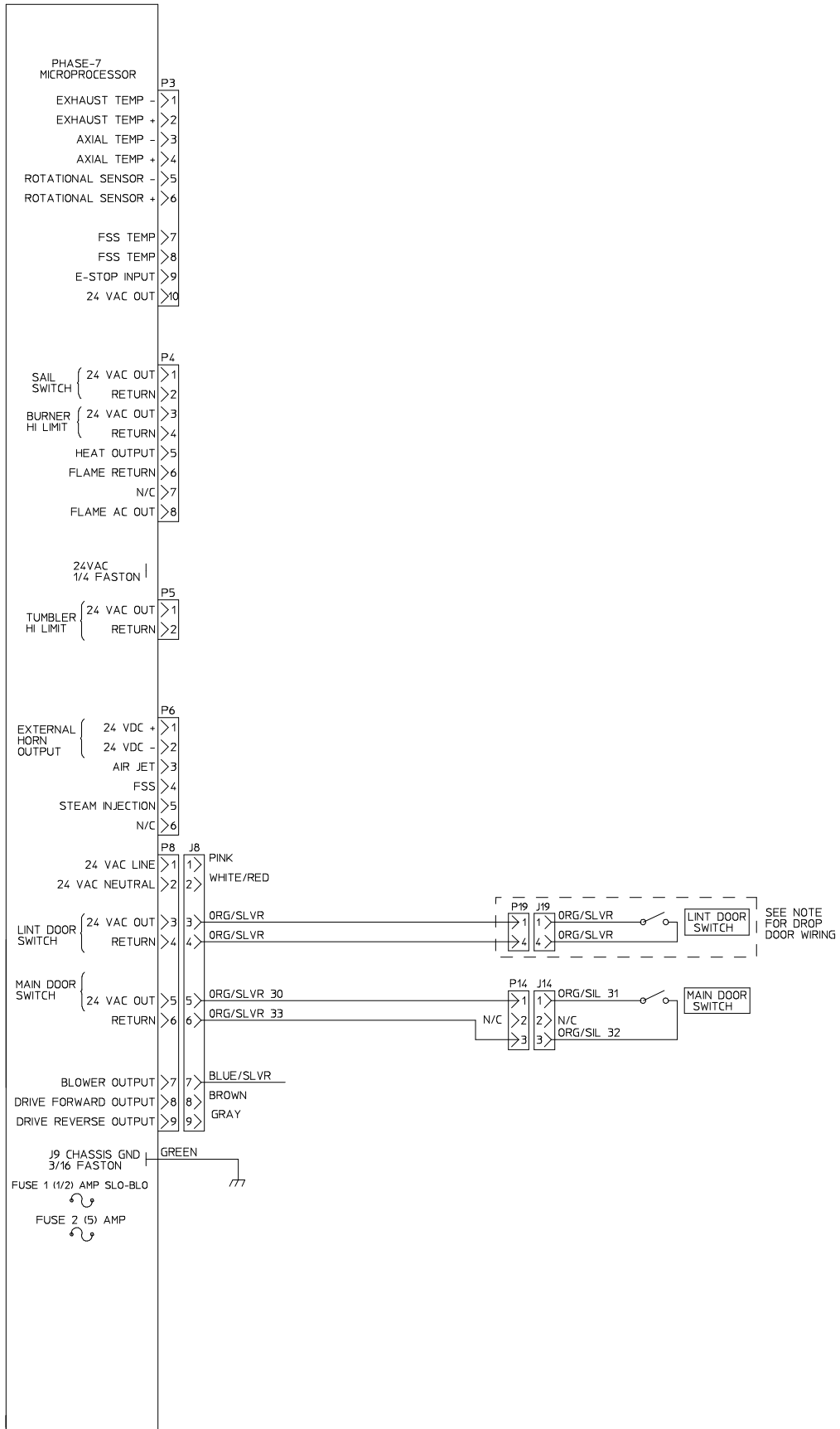

MAN6541

WM 2/6/03

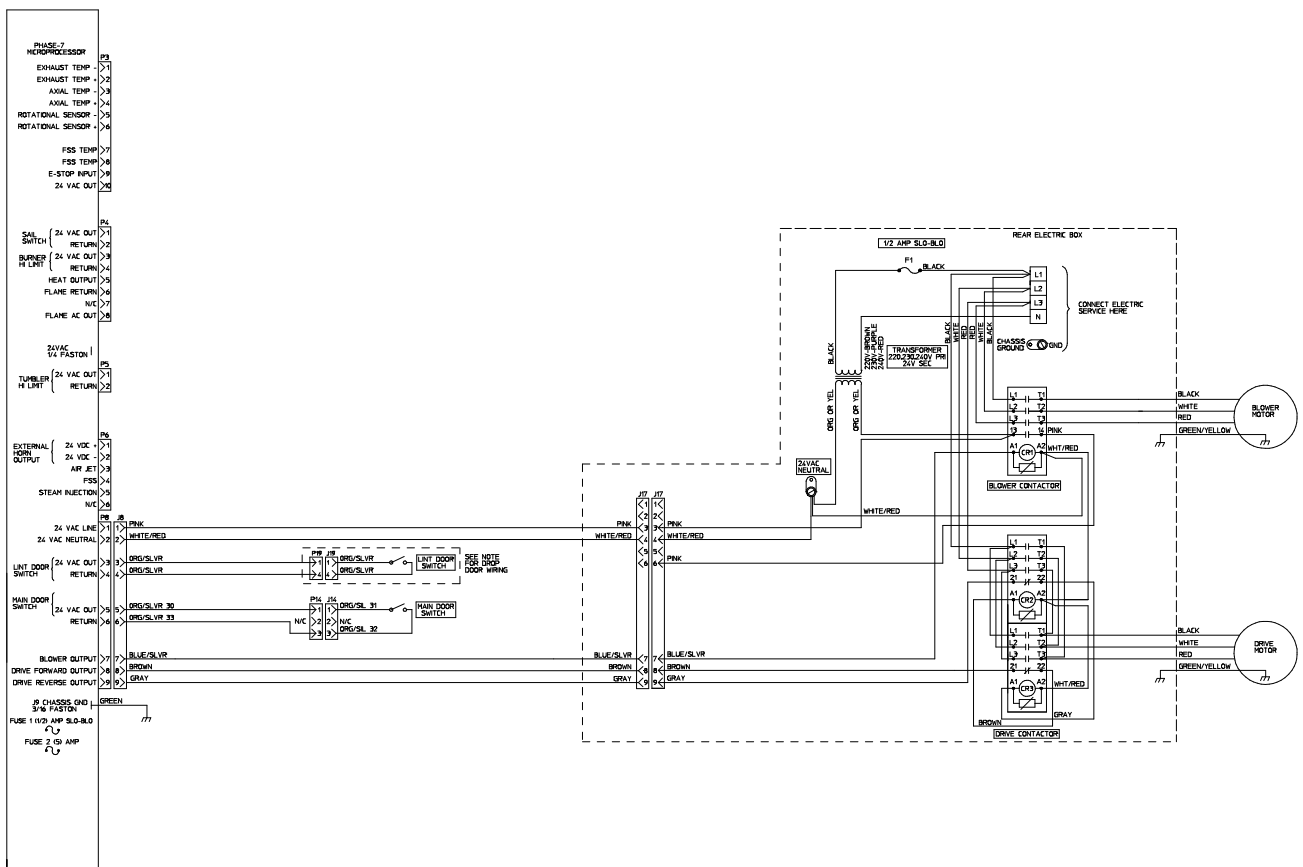

AS 1/24/03

MAN6472

SECTION VII

DATA LABEL INFORMATION

A. DATA LABEL

Contact **ADC**

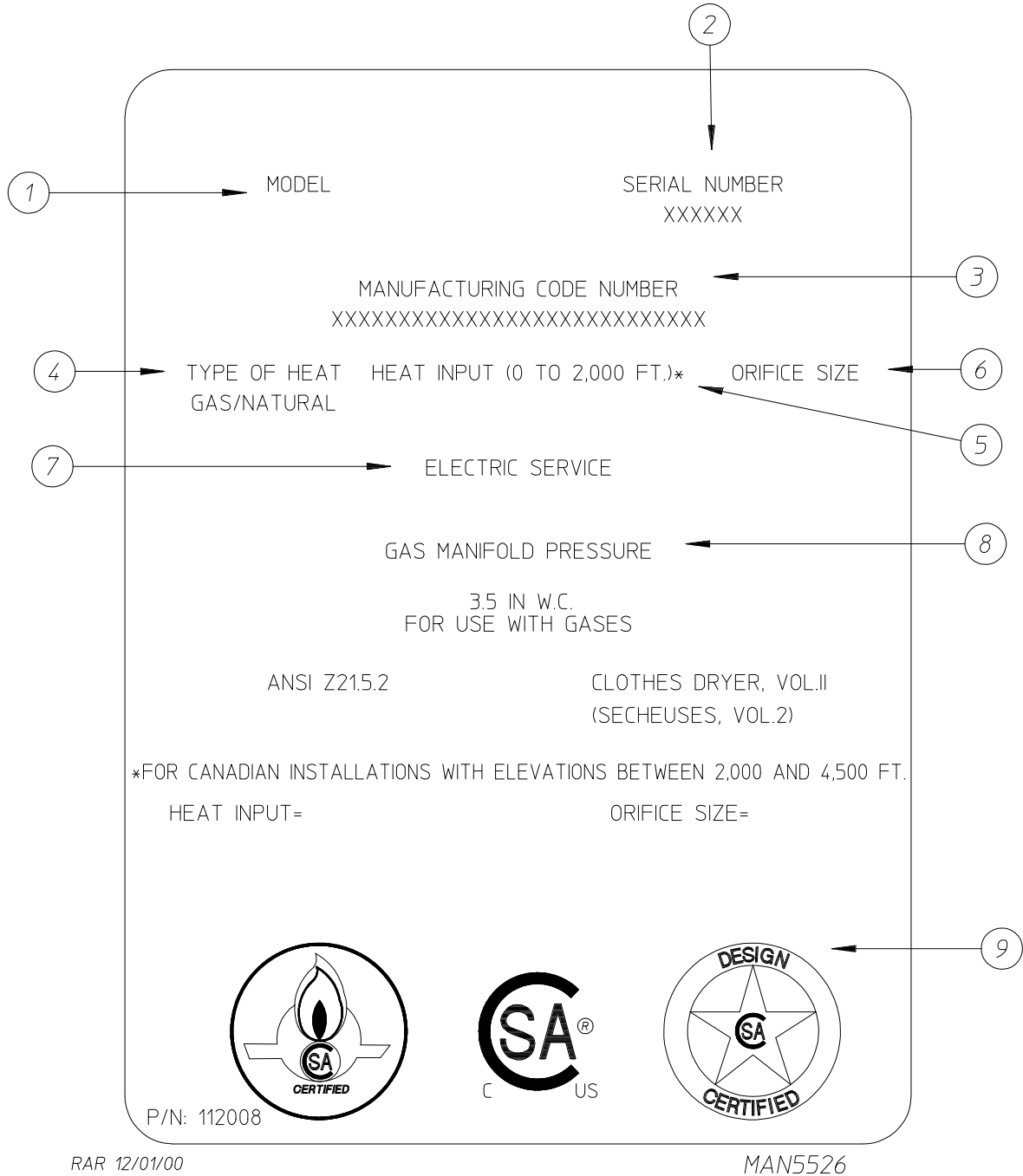

When contacting **ADC**, certain information is required to insure proper service/parts information from **ADC**. This information is on the data label affixed to the left side panel/wall area behind the control door. When contacting **ADC**, please have the **model number** and **serial number** available.

THE DATA LABEL

1. MODEL NUMBER

The model number is an **ADC** number, which describes the size of the dryer and the type of heat (gas, electric, or steam).

2. SERIAL NUMBER

The serial number allows **ADC** to gather information on your particular dryer.

3. MANUFACTURING CODE NUMBER

The manufacturing code number is a number issued by the manufacturer, which describes **ALL** possible options on your particular model.

4. TYPE OF HEAT

This describes the type of heat for your particular dryer: gas (either natural gas or liquid propane [L.P.] gas) or steam.

5. HEAT INPUT (for GAS DRYERS)

This describes the heat input in British Thermal Units per Hour (BTUH).

6. ORIFICE SIZE (for GAS DRYERS)

Gives the number drill size used.

7. ELECTRIC SERVICE

This describes the electric service for your particular model.

8. GAS MANIFOLD PRESSURE (for GAS DRYERS)

This describes the manifold pressure taken at the gas valve tap.

9. APPLICABLE APPROVAL SEAL(S)

I.E., Canadian Standards Association International.

B. USING A MANOMETER

HOW TO USE A MANOMETER

1. With dryer in nonoperating mode, remove plug on the gas valve pressure tap.
2. Install 1/8" N.P.T. fitting supplied with the manometer.
3. Attach plastic tubing to pressure tap fitting.
4. Attach manometer to dryer using magnet.



NOTE: Place manometer in a position so that readings can be taken at eye level.

5. Fill manometer as shown in illustration to the zero level.
6. Start dryer. With burner on take a reading.
 - a. Read water level at the inner tube. Readings **should be** taken at eye level.
 - b. Correct readings **should be:**

Natural Gas 3.5 Inches (8.7 mb) Water Column (W.C.)
Liquid Propane (L.P.) Gas 10.5 Inches (26.1 mb) Water Column (W.C.)

7. If water column pressure is incorrect, refer to "TO ADJUST GAS PRESSURE."
8. Reverse procedure for removing manometer.

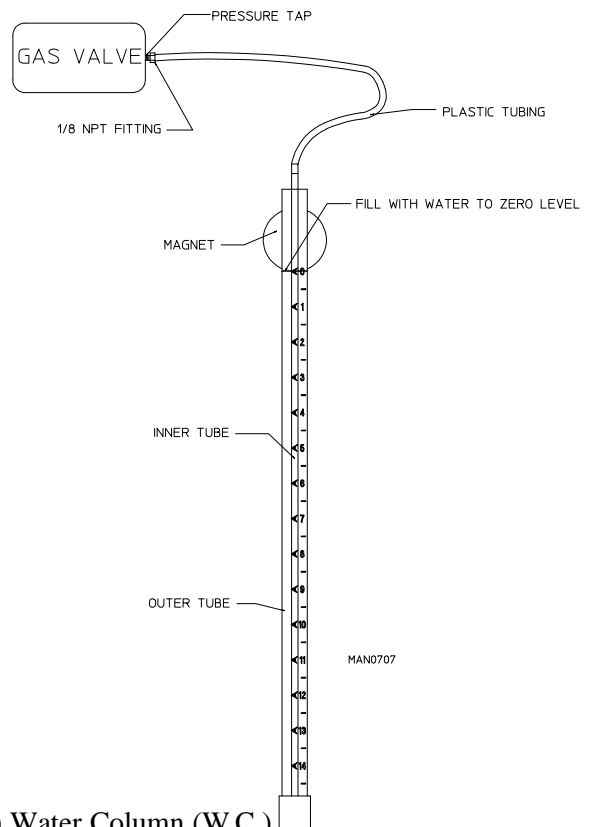

C. KEYBOARD (TOUCHPAD) LAYOUT

1. Dot Matrix Display
2. A-F Preprogrammed Cycles
3. Stop/Pause Button
4. Start Button
5. Increment Button
6. Decrement Button
7. One time auto (Dryness level) and manual (timed) Cycle

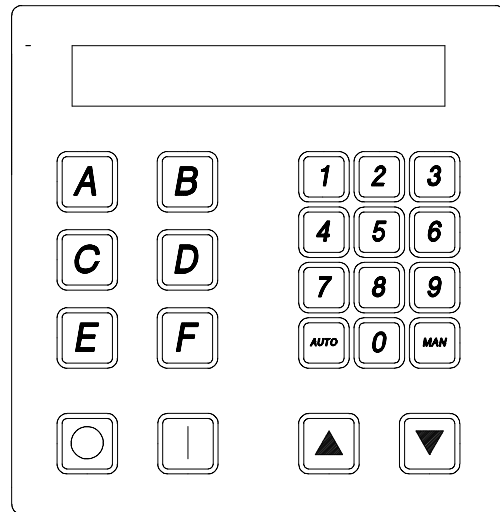

MC 8/02/01

MAN5846



NOTE: Fuse 1 is for computer power rated at 1/2-Amp. If fuse blows, it is a computer board fault. Fuse 2 is for 24V control power rated at 5-Amp. If fuse blows, it is a 24V control fault.

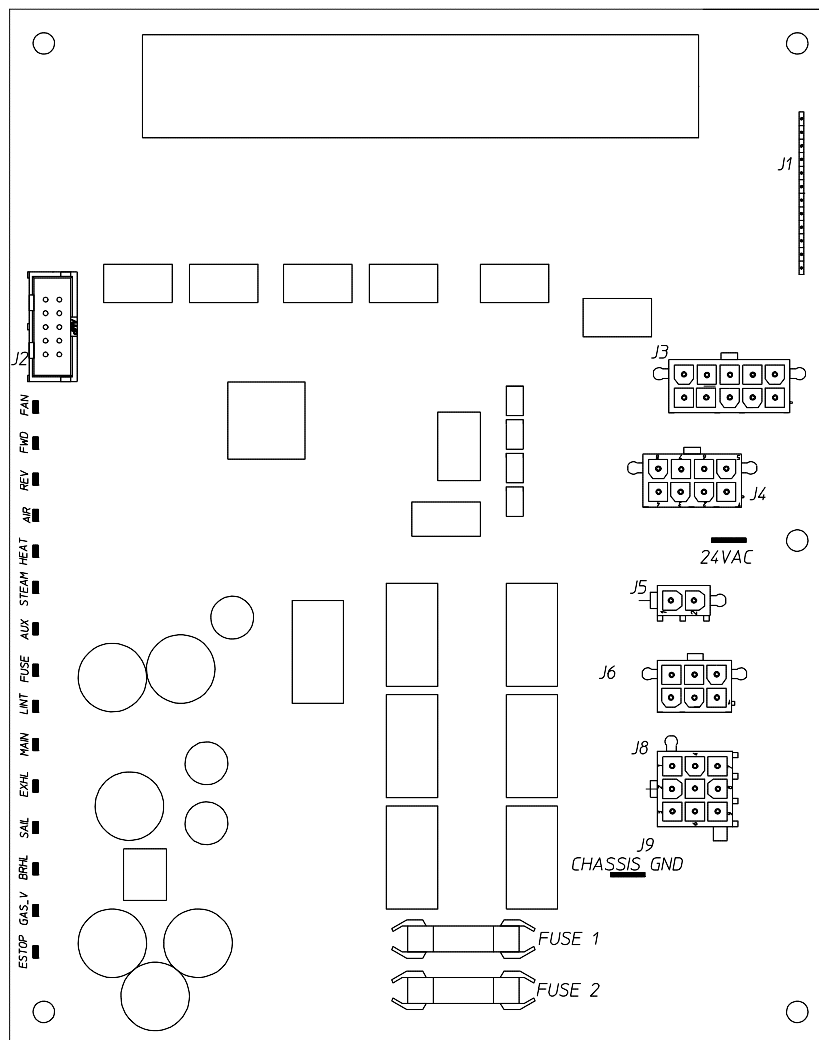

MAN5825

D. SENSOR ACTIVATED FIRE EXTINGUISHING (S.A.F.E.) SYSTEM

THEORY OF OPERATION

While the dryer is in an idle state or 20-seconds after the heat turns off, the Phase 7 control monitors the S.A.F.E. system probe located in the top of the basket (tumbler) chamber and records the minimum temperature. If the minimum recorded S.A.F.E. system probe temperature is no less than 120° F (48° C) and the control detects a 50° rise in temperature, this will be the trip point and the S.A.F.E. system routine will activate.

While a drying cycle is in process and the heat has turned on at least once, the Phase 7 control monitors the exhaust temperature transducer. If the drying cycle temperature set point is set greater than 160° F (71° C) and the control detects an exhaust temperature rise 25° F greater than set point, this will be the trip point and the S.A.F.E. system routine will activate. If set point is below 160° F (71° C) the trip point will be 185° F (85° C).

Once the S.A.F.E. system routine is activated, water will be injected into the basket (tumbler) chamber. Anytime water is being injected into the basket (tumbler); the basket (tumbler) drive will turn the load for 1-second every 15-seconds. This process will continue for a minimum of 2 minutes. After 2 minutes has elapsed, the control will check if the temperature remained above trip point, if so water will remain on. The control will continue to check if temperature is above trip point every 30-seconds. If the water has been on for a constant 10 minutes, the water will be turned off regardless of the temperature. If the temperature has dropped below trip point, the control will turn off the water prior to 10 minutes.

SYSTEM RESET

After the microprocessor determines that the situation is under control and shuts the water being injected into the basket (tumbler) off, the microprocessor display will read “S.A.F.E. System activated,” and the horn/tone will sound until reset manually.

To reset the microprocessor once the control displays “S.A.F.E. System activated,” press the red  key on the keyboard (touch pad).

OPL S.A.F.E. SYSTEM CHECK PROCEDURE

The operation of the water solenoid valve can be tested to insure that the water supply system and valve are functional. Before attempting system check, be sure that **ALL** water supply shutoff valves to the dryer are in the OPEN position, and the dryer **must be** in the “READY” mode where no cycle is loaded or in progress.

The procedure is as follows:

1. Press and hold the RED STOP key (while in “READY” mode and no cycle in progress).
2. Press and hold the “A” key.
3. Water valve will open and water will be dispensed into basket (tumbler) area as long as both keys are held.



IMPORTANT: This is a test function only and the keys *should be* held and system activated for only a second or so, otherwise water will accumulate in various places in the dryer.

E. STATIC PRESSURE

The pressure of the air in sheet metal ducts is of great importance for safe and efficient operation of the dryer. The air pressures, as small as they are, have a large influence upon the performance of the dryer. There are three (3) pressures present within a duct. The velocity pressure, which is the pressure due to the moving stream of air, the static pressure, which is the outward push of the air against the walls of the duct, and the total pressure, which is the sum of the static and velocity pressures. Only the total and static pressures can be measured. The velocity pressure is then calculated from the difference between the two. The static pressure is the most influential and determining factor in the design of a dryer duct system. **ADC** recommends that the dryer exhaust duct static pressure not exceed 0.3 inches (0.74 mb) of water column (W.C.).

Gages used to measure such small air pressures utilize the elevation of a column of water. This form of gage is called a manometer. One form of this gage is known as a U-tube and is shown in **Illustration #1**. When one end of the tube is connected to the duct, the static (outward) pressure within the duct forces the water column to be depressed in one leg of the U-tube and up in the other. The elevation of the water column in **Illustration #1** is 3.2 inches (8 mb).

Illus. #1

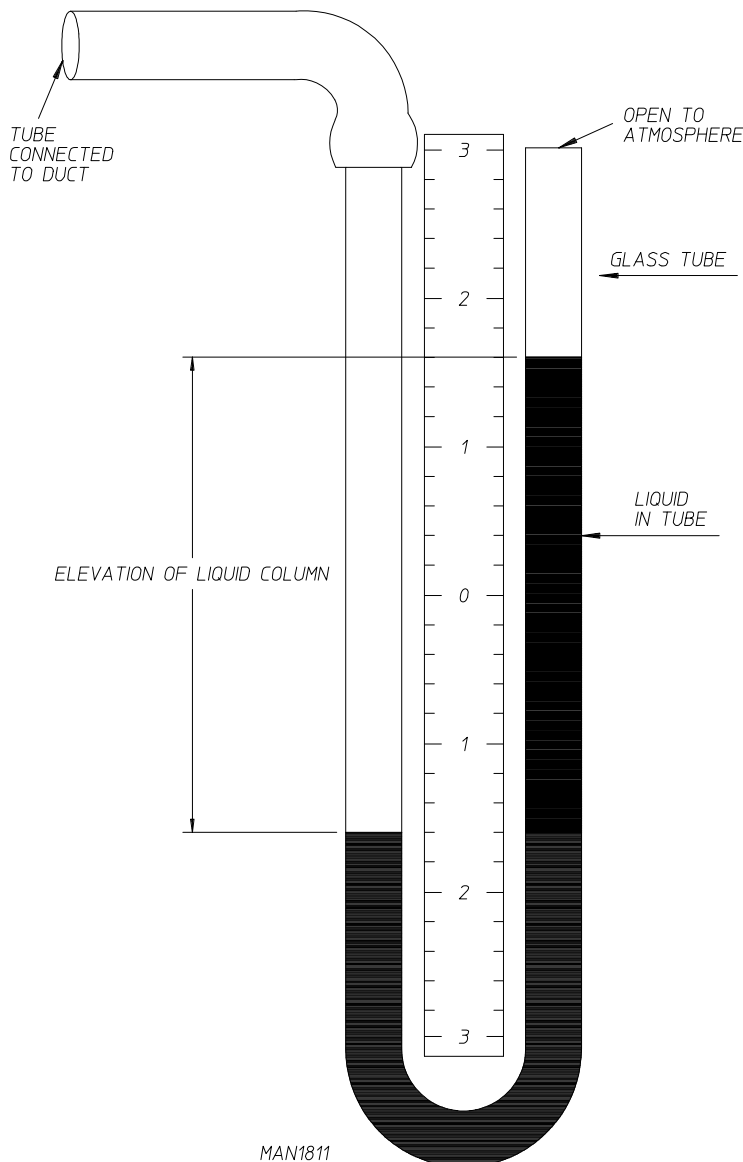

F. USING A MAGNEHELIC

When measuring such small air pressures, the U-tube is often not accurate enough. Such small differences in pressure are most often measured by an inclined tube manometer or a Magnehelic pressure gage as shown in **Illustration # 2**.

Illus. # 2

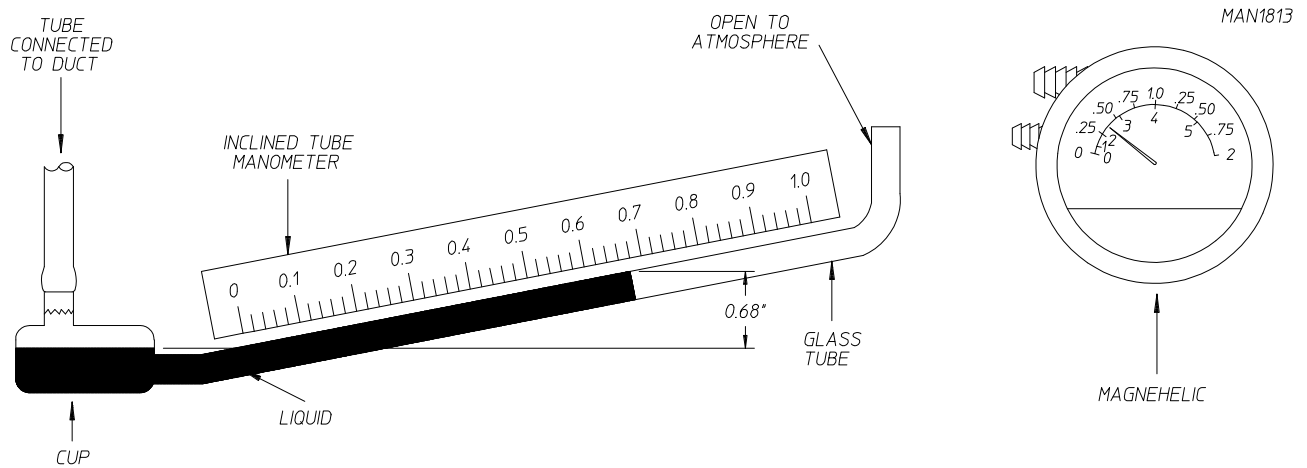

For convenience and accuracy, an instrument known as a Pitot tube is used with the gage. The Pitot tube, as shown in **Illustration #3**, consists of two tubes – one within the other. The inner tube measures the total pressure alone, while the outer tube measures the static pressure alone.

Illus. # 3

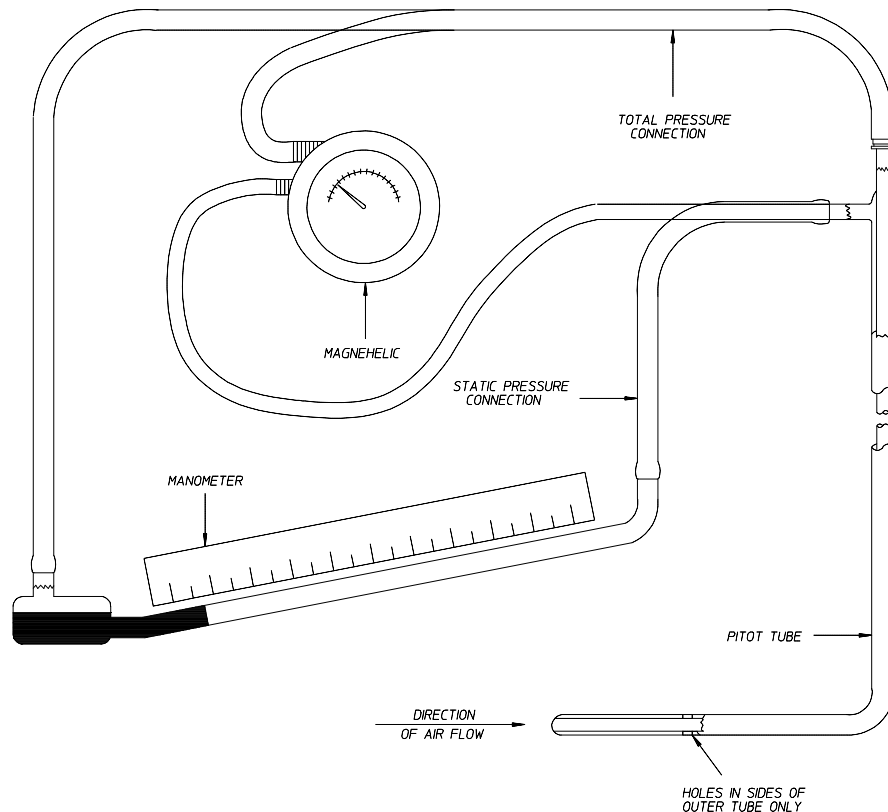

MAN1812

To obtain the most accurate static pressure readings of a dryer, the following guidelines **should be** conformed to. The reading **should be** taken in a straight section of duct, a minimum of ten (10) times the diameter of the duct (i.e. 10" [25.4 cm] diameter duct, a straight section 100" [254 cm] in length). The reading **should be** taken a minimum of 8-1/2 times the diameter upstream of the dryer or nearest elbow, and 1-1/2 times the diameter downstream of the Pitot tube. The following is an example showing the proper location to take a static pressure reading.

SINGLE DRYER VENTING

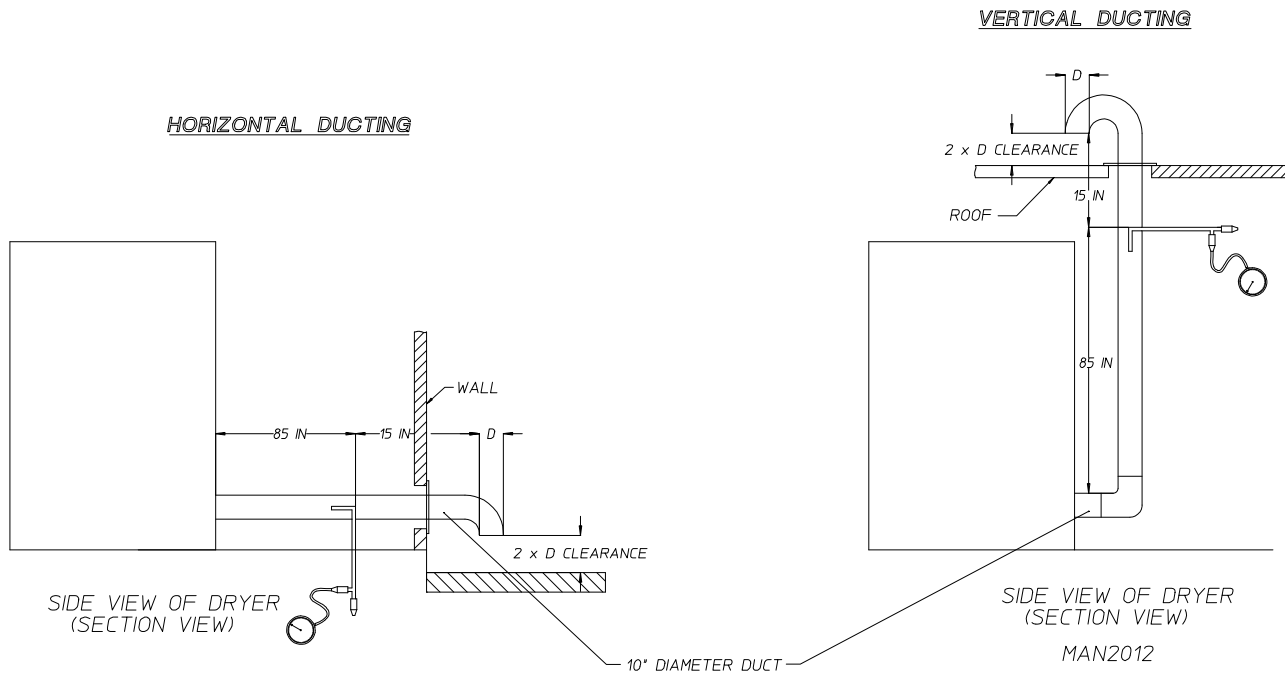

In designing a dryer exhaust duct system, it is not necessary to compute the friction loss of the ductwork. The friction loss (static pressure) is predetermined to not exceed 0.3 inches (0.74 mb) of water column (W.C.). This maximum allowable static pressure is the same for **ALL** model dryers and is calculated to provide maximum dryer efficiency. It is necessary to determine the total equivalent length of the duct system. The total equivalent length of the duct system is the actual length of the duct added to the equivalent length of **ALL** the fittings. The equivalent length of a fitting, is the length of straight duct of the same size as the fitting in which the friction losses are equal. Equivalent lengths **must be** determined for **ALL** elbows, as well as, any entries which may be incorporated into a common duct system for multiple dryers. The total equivalent length is then used with the total cfm (cubic feet per minute) exhaust rating of the dryer(s) to calculate the minimum round duct diameter. When designing a single common duct system for multiple dryers, each individual dryer exhaust duct enters the main common duct.

